

DISHWASHER

ELECTROMECHANICAL SWITCHES
LOWER AND UPPER WASHING

TYPE: 9U

Accessories

BREAK TANK

BOOSTER PUMP

DVGW

COLD RINSE

WATER SOFTNER

DETERGENT DISPENSER

DRAIN PUMP

Spare Parts Manual

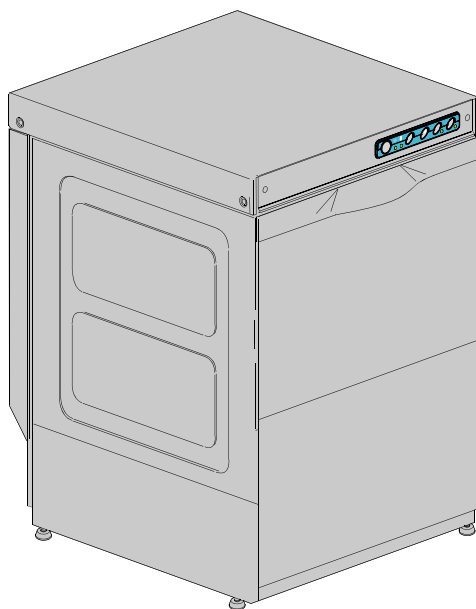

Parti di ricambio

Spare Parts

Catalogues pièces

Plezas de recambis

Ersatzteile

INFORMAZIONI GENERALI

Questo catalogo serve per richiedere con esattezza le parti di ricambio

Nelle ordinazioni indicare:

1) il numero dei codici dei particolari seguito dalla descrizione e la quantità desiderata;

2) Il codice alfa-numerico presente nella seconda colonna della tabella ;

I disegni delle parti di ricambio sono solo indicativi e non rappresentano il pezzo in oggetto.

I dati contenuti in questo catalogo sono indicativi e possono essere soggetti a modifiche senza impegno di preavviso.

ALLGEMEINE INFORMATIONEN

Dieser Ersatzteilkatalog dient zur genauen Angabe der Teile bei Ersatzteilbestellungen.

Bei Ersatzbestellung ist folgendes anzugeben:

1) Die Bestellnummer der Ersatzteile mit der entsprechenden Beschreibung genaue Menge;

2) Der alpha-numerischer Code auf der zweiten Reihe in dein Spult;

Die Zeichnungen der Ersatzteile sind nur als Hinweise gedacht und stellen nicht das betroffene Teil dar.

Bei den im Katalog angeführten Daten handelt es sich um Anhaltsdaten, die jederzeit, ohne Vorankündigung, geändert werden können.

GENERAL INFORMATION

The present spare parts order exactly the right spare parts

When ordering specify:

1) the part's code number followed by its description and quantity needed;

2) The alpha-numeric code is in the second column in the chart;

Spare parts drawings are general and do not represent the part.

The contents of this catalogue are general and can undergo changes without prior notice.

INFORMACIONES GENERALES

El presente catálogo sirve para pedir con exactitud las partes de repuesto

En los pedidos se debe indicar:

1) el número de código de la parte y a continuación la descripción cantidad deseada;

2) El código alfanumerico presente en la segnada columna de la tabla;

Los diseños de las partes de recambio son solo indicativos y no representan la pieza en cuestión.

Los datos contenidos en el presente catálogo son indicativos y pueden modificarse sin aviso previo.

INFORMATIONS GENERALES

Ce catalogue permet de commander correctement les pièces détachées

Les commandes doivent être passées en indiquant:

1) le numero de code des pièces détachées suivi de leur description quantité désirée;

2) le code alphanumérique dans la deuxième colonne du tableau;

Les plans des pièces détachées sont fournis seulement à titre indicatif et ne représentent pas la pièce concernée.

Les données de ce catalogue sont citées seulement à titre indicatif et peuvent être l'objet de modifications sans avis préalable.

ESEMPIO EXAMPLE EXEMPLE BEISPIEL

Rif.	Codici
MODULE:Particolari	
10505	540903
10510	540908
10515	15065/A
10520	540086
10525	540028



Note

Tutte le informazioni riportate si intendono aggiornate alla data di stampa. Il Produttore si riserva il diritto di apportare qualsiasi modifica richiesta dallo sviluppo evolutivo dei suddetti prodotti.

Per la sicurezza ,la garanzia, l'affidabilità ed il valore della lavastoviglie usa solo ricambi originali. **Per alcuni codici, sono richieste quantità minime d'ordine.**



Attenzione

Questo libretto è parte integrante della lavastoviglie e, in caso di passaggio di proprietà, deve essere consegnato al nuovo acquirente.



Remarque

Toutes les informations contenues dans ce manuel s'entendent mises à jour à la date d'impression. En raison du développement constant de ses produits, usine se réserve le droit d'apporter à tout instant les modifications qu'elle jugera utiles.

Pour la sécurité, la garantie, la fiabilité et la valeur de votre lavevaisselles, en cas de transfert de propriété, doit toujours être remis au nouveau propriétaire. **Pour quelque référence on demande un minimum de pièces par commande**



Attention

Ce manuel doit être considéré comme partie intégrante de la lavevaisselles, en cas de transfert de propriété, doit toujours être remis au nouveau propriétaire.



Note

The information contained herein is valid at the time of going to print. The Company reserves the right to make any changes required by the future development of the above-mentioned products.

For your safety, as well as to preserve the warranty reliability and worth of your dishwashers, use original spare parts only. **For some codes a minimum quantity for order is required.**



Warning

This manual forms an integral part of the dishwashers and - if a transfer of title occurs - must always be handed over to the new owner.



Hinweis

Die Der Hersteller behält sich das Recht vor, jegliche, durch eine Weiterentwicklung der genannten Produkte bedingte Änderungen vornehmen zu können.

Verwenden Sie für Ihre Sicherheit, die Garantie, die Zuverlässigkeit und den Wert Ihrer machine originale Ersatzteile. **Für bestimmte Code nummer werden mindesten bestellungen verlangt.**



Achtung

Diese Betriebsanleitung ist Bestandteile des machine und muss bei seinem Weiterverkauf dem neuen Besitzer ausgehändigt werden.

Parti di ricambio

Spare Parts

Catalogues pièces

Plezas de recambis

Ersatzteile





Code DW 999XXXXXX **CL/Part**

Model DESCRIPTION

S/N DW A 1015770 **Type**

400V 3N 50HZ 8A
3500W 500W

  16A

Pressione Dinamica alimentazione idrica 200-500 kPa
Pression dynamique arrivèe d'eau
Dynamic pressure water supply
Dynamischer Druck asserreinlauf

Pressione dinamica vapore saturo
Pression dynamique vapore satueèe
Dymanischer Druck gesattigter Dampf
Pression Dinamica Vapor Saturado

TECHICAL SPECIFICATION



MADE IN ITALY

Temperatura massima acqua in ingresso 60°C
Temperature max eau a l'entre
Maximale Temperatur Wasseranschlu
Maximum Water temperature in-feeding

Model 

S/N 

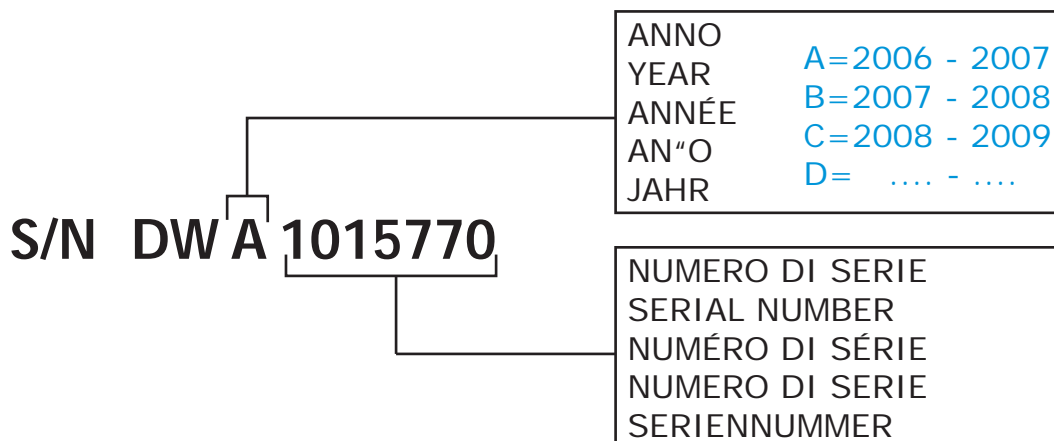
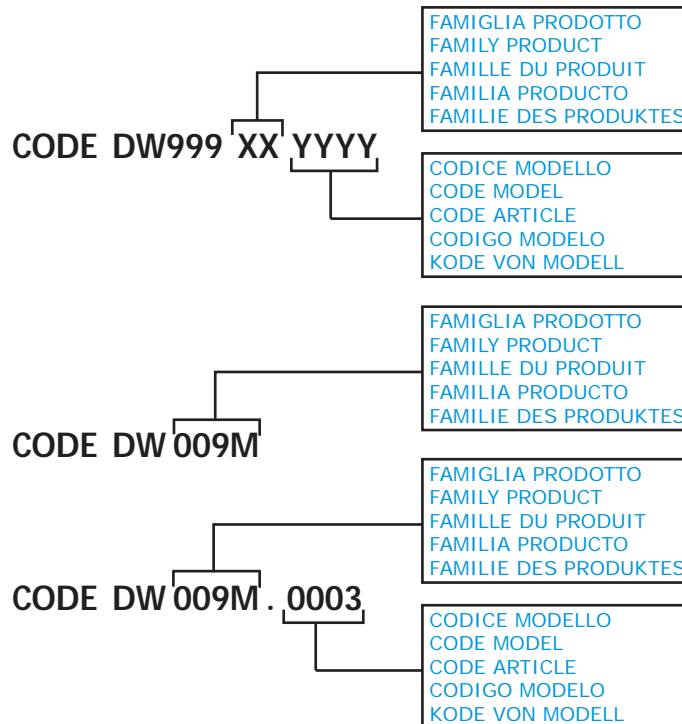

POSIZIONE MATRICOLA / LOCATION OF SERIAL NUMBER / EMBLACEMENT DU NUMERO DE SERIE

MATRICOLA
SERIAL NUMBER
NUMERO DE DERIE

MATRICOLA
SERIAL NUMBER
NUMERO DE DERIE

MATRICOLA
SERIAL NUMBER
NUMERO DE DERIE

MATRICOLA
SERIAL NUMBER
NUMERO DE DERIE

MATRICOLA
SERIAL NUMBER
NUMERO DE DERIE

MATRICOLA
SERIAL NUMBER
NUMERO DE DERIE

MATRICOLA
SERIAL NUMBER
NUMERO DE DERIE

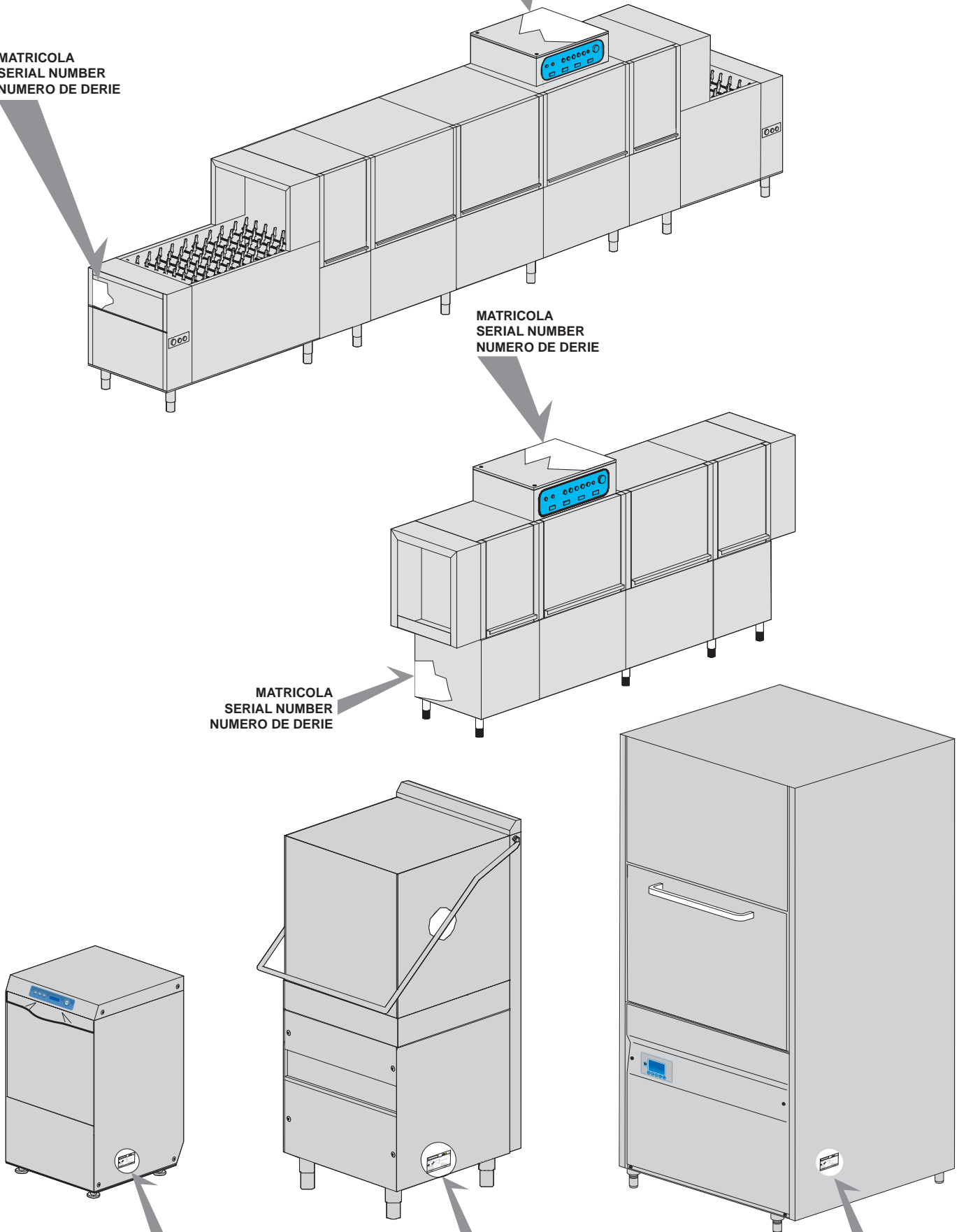

1. Spare parts

General body parts.....	9
Lockup system	13
Control panel and switches.....	15
Electric control components.....	17
Solenoid valve group	19
Solenoid valve group	21
Break Tank	23
Booster pump.....	25
DVGW	27
Water softner group.....	29
Rinse aid dispenser group.....	31
Rinse aid dispenser group.....	33
Boiler group	35
3 ways connection	37
4 ways connection	39
Wash pump	41

Wash pump	43
Dosing detergent group.....	45
Drain pump group.....	47
Pressure switch group with air trap ...	49
Turret group with rotating arms	51
Turret group with rotating arms	55
Turret group with rotating arms	57
Turret group with rotating arms	59

1.1 Voltage codes

Volt	Voltage code
A	3/N/PE~380-400V 50-60Hz
D	3/PE~200-210V 50-60Hz
F	2/PE~220-240V 50-60Hz
G	3/N/PE~415V 50-60Hz
H	3/PE~220-230V 50-60Hz
K	3/PE~380-400V 50-60Hz
L	3/PE~415V 50-60Hz
M	3/PE~440V 60Hz
P	1/N/PE~220-230V 50-60Hz
R	2/PE~220-240V 50-60Hz
U	1/N/PE~240V 50-60Hz
V	3/PE~240V 50-60Hz
W	1/N/PE~100-110V 50-60Hz

1.2 Product codes

Product code	Full name
Model codes	
em	ELECTROMECHANICAL SWITCHES
uw	LOWER AND UPPER WASHING
Type codes	
9U	9U
Accessory codes	
bt	BREAK TANK
bp	BOOSTER PUMP
dvgw	DVGW
cr	COLD RINSE
ws	WATER SOFTNER
dd	DETERGENT DISPENSER
dp	DRAIN PUMP

Spare parts

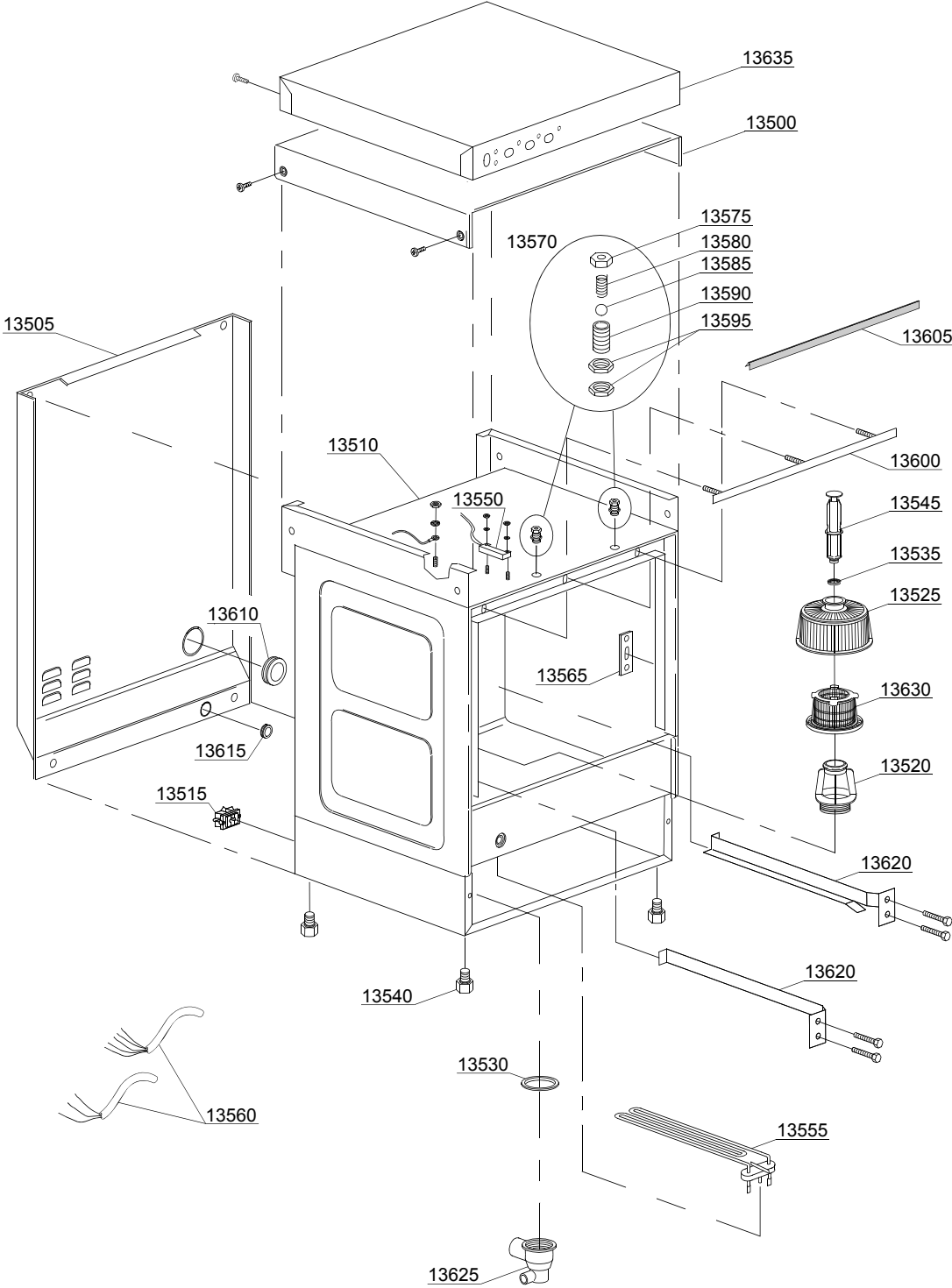

01_015_e

Spare parts

ID	P-code	SN from	SN to	Mod.	Acces.	Volt	Description
Module:General body parts							
13500	500904		-				Cover
13505	500909		-				Back panel
13510	500900		-				Body
13510	500900/A		-		ws		Body
13515	15065/A		-				Cable-fastener with screw
13520	500607		-				Ferrule with filter
13525	500616		-				Suction filter
13530	80208		-				95x75x3 O-ring (minimum 2 pieces)
13535	13021		-				DEM 40 O-ring (minimum 2 pieces)
13540	10851		-				Foot (minimum 4 pieces)
13545	500618		-				Overflow pipe
13550	10778		-				Reed magnet
13555	150047		-				2,7/2,94KW 230/240V heating element
13555	16035/A		-				2,18/2,37KW 230/240V 50Hz heating element
13555	15047/E		-				2,5/2,72KW 230/240V heating element
13555	150047/A		-				2,7KW heating element - 440V
13555	16035/B		-				1,6KW 110V 60Hz heating element
13560	15118		-				5x2,5x2500 cable
13560	15104/B		-				3x4x2500 cable
13560	10713		-				3x2,5x2500 cable
13560	15145		-				4x4x2500 cable
13565	150401		-				Door rod slide (minimum 4 pieces)
13570	10775		-				Door jack assembly
13575	10802		-				Door jack locknut (minimum 3 pieces)
13580	10777		-				Spring for door hook
13585	10776		-				Sphere for door hook
13590	10803		-				Door jack body
13595	10801		-				Door jack nut (minimum 5 pieces)

em=ELECTROMECHANICAL SWITCHES, uw=LOWER AND UPPER WASHING

9U=9U

bt=BREAK TANK, bp=BOOSTER PUMP, dvgw=DVGW, cr=COLD RINSE, ws=WATER SOFTNER, dd=DETERGENT DISPENSER, dp=DRAIN PUMP

A=3/N/PE~380-400V 50-60Hz, D=3/PE~200-210V 50-60Hz, F=2/PE~220-240V 50-60Hz, G=3/N/PE~415V 50-60Hz, H=3/PE~220-230V 50-60Hz, K=3/PE~380-400V 50-60Hz, L=3/PE~415V 50-60Hz, M=3/PE~440V 60Hz, P=1/N/PE~220-230V 50-60Hz, R=2/PE~220-240V 50-60Hz, U=1/N/PE~240V 50-60Hz, V=3/PE~240V 50-60Hz, W=1/N/PE~100-110V 50-60Hz

Spare parts

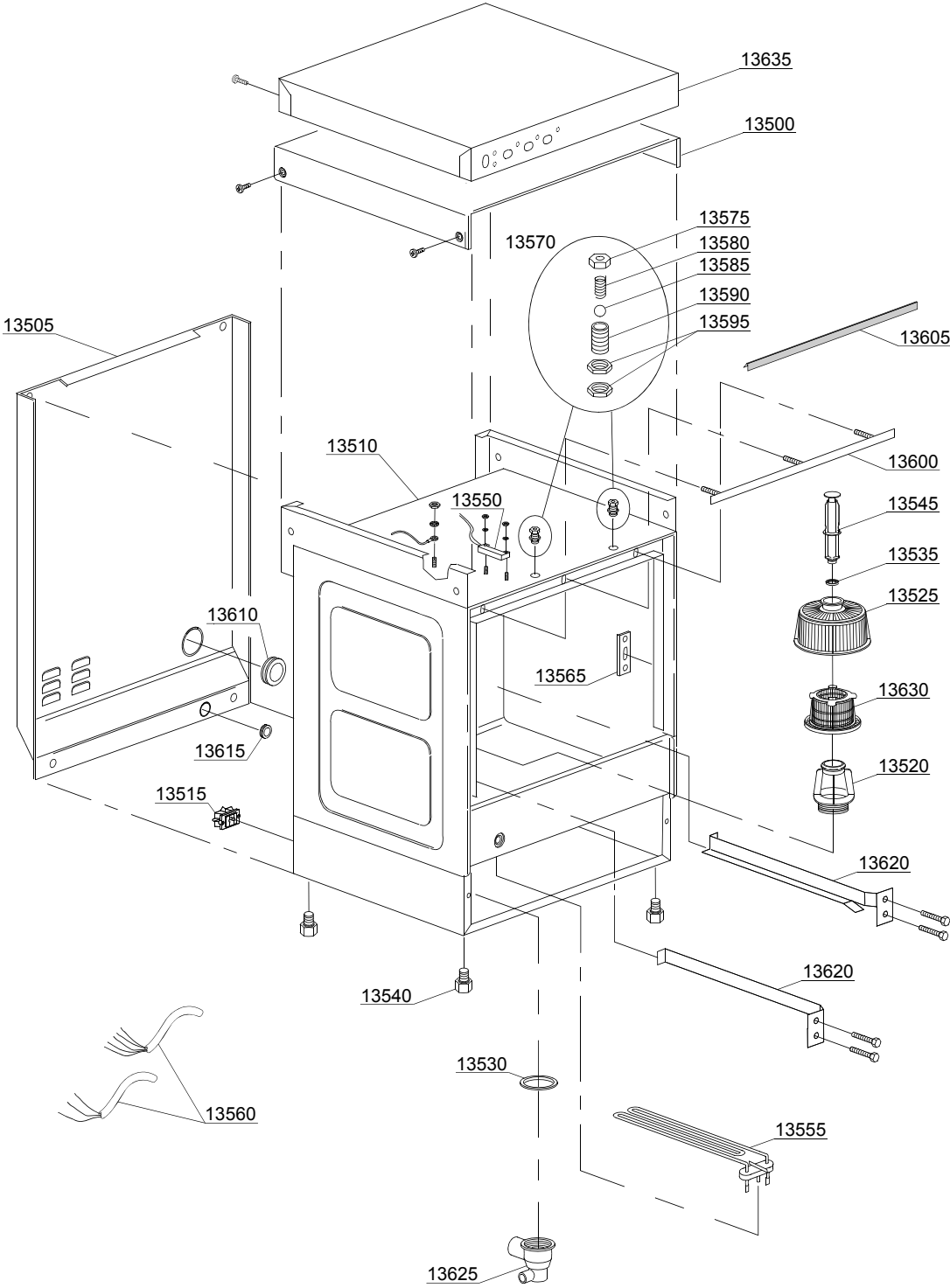

01_015_e

Spare parts

ID	P-code	SN from	SN to	Mod.	Acces.	Volt	Description
Module:General body parts							
13600	150921		-				Door O-ring angular
13605	135205		-				Door O-ring
13610	13317		-				D.40mm unloading pipe pass (minimum 2 pieces)
13615	13323		-				D.13mm dosing pipe pass (minimum 2 pieces)
13620	500902		-				Right/left internal slide
13625	500606		-				Right side scrap tray
13630	500600		-				Interior filter with rack

em=ELECTROMECHANICAL SWITCHES, uw=LOWER AND UPPER WASHING

9U=9U

bt=BREAK TANK, bp=BOOSTER PUMP, dvgw=DVGW, cr=COLD RINSE, ws=WATER SOFTNER, dd=DETERGENT DISPENSER, dp=DRAIN PUMP

A=3/N/PE~380-400V 50-60Hz, D=3/PE~200-210V 50-60Hz, F=2/PE~220-240V 50-60Hz, G=3/N/PE~415V 50-60Hz, H=3/PE~220-230V 50-60Hz, K=3/PE~380-400V 50-60Hz, L=3/PE~415V 50-60Hz, M=3/PE~440V 60Hz, P=1/N/PE~220-230V 50-60Hz, R=2/PE~220-240V 50-60Hz, U=1/N/PE~240V 50-60Hz, V=3/PE~240V 50-60Hz, W=1/N/PE~100-110V 50-60Hz

Spare parts

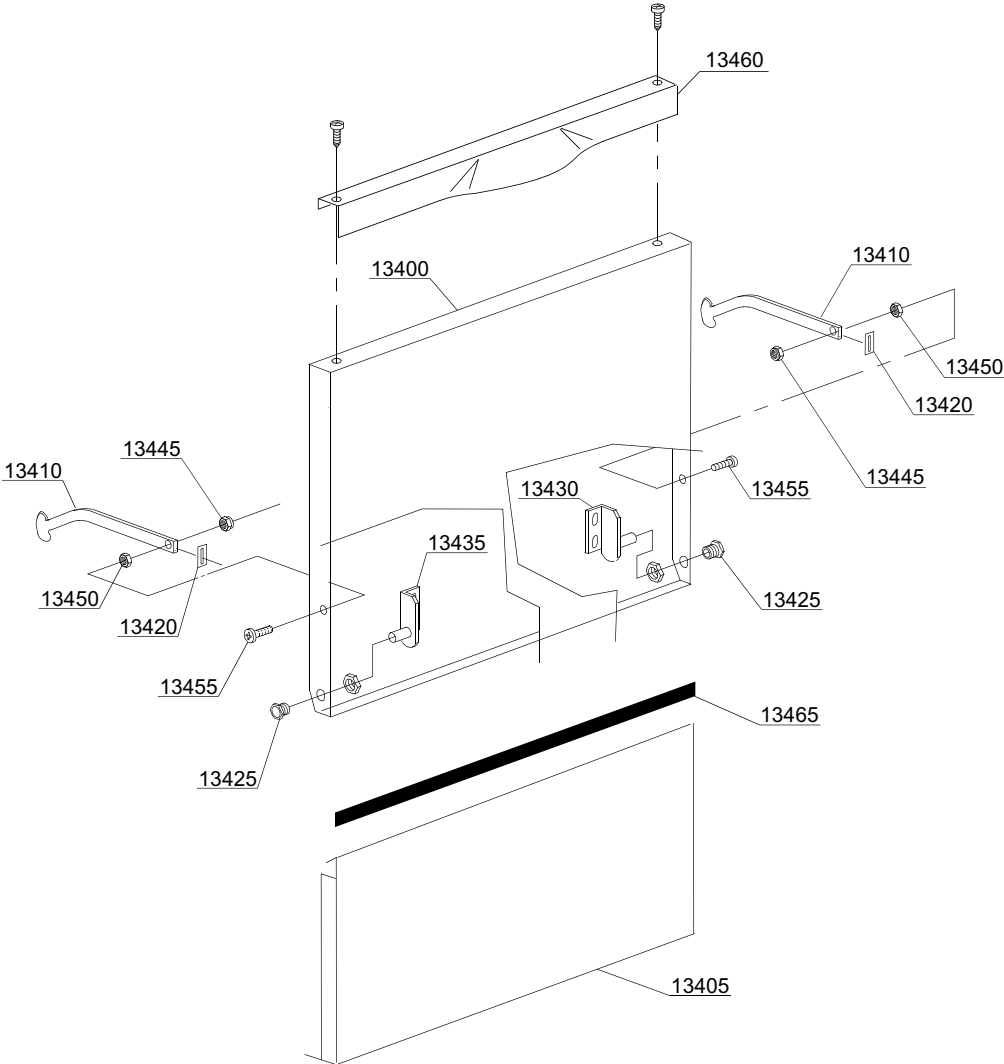

02_112_e

Spare parts

ID	P-code	SN from	SN to	Mod.	Acces.	Volt	Description
Module: Lockup system							
13400	500943		-				Door
13405	500903		-				Lower door
13410	150221		-				Right/left door rod
13420	135222		-				Hinge door seal
13425	11835/A		-				Brass bush
13430	150210		-				Right hinge door
13435	150211		-				Left hinge door
13445	11721		-				M6 self-locking nut (minimum 10 pieces)
13450	11706		-				M6 stainless steel nut (minimum 20 pieces)
13455	11111		-				M6x16 stainless steel screw (minimum 10 pieces)
13460	500930/D		-				Stainless steel handle
13465	15751		-				20x4 self-extinguishing adhesive lem mousse
			-				

em=ELECTROMECHANICAL SWITCHES, uw=LOWER AND UPPER WASHING

9U=9U

bt=BREAK TANK, bp=BOOSTER PUMP, dvgw=DVGW, cr=COLD RINSE, ws=WATER SOFTNER, dd=DETERGENT DISPENSER, dp=DRAIN PUMP

A=3/N/PE~380-400V 50-60Hz, D=3/PE~200-210V 50-60Hz, F=2/PE~220-240V 50-60Hz, G=3/N/PE~415V 50-60Hz, H=3/PE~220-230V 50-60Hz, K=3/PE~380-400V 50-60Hz, L=3/PE~415V 50-60Hz, M=3/PE~440V 60Hz, P=1/N/PE~220-230V 50-60Hz, R=2/PE~220-240V 50-60Hz, U=1/N/PE~240V 50-60Hz, V=3/PE~240V 50-60Hz, W=1/N/PE~100-110V 50-60Hz

Spare parts

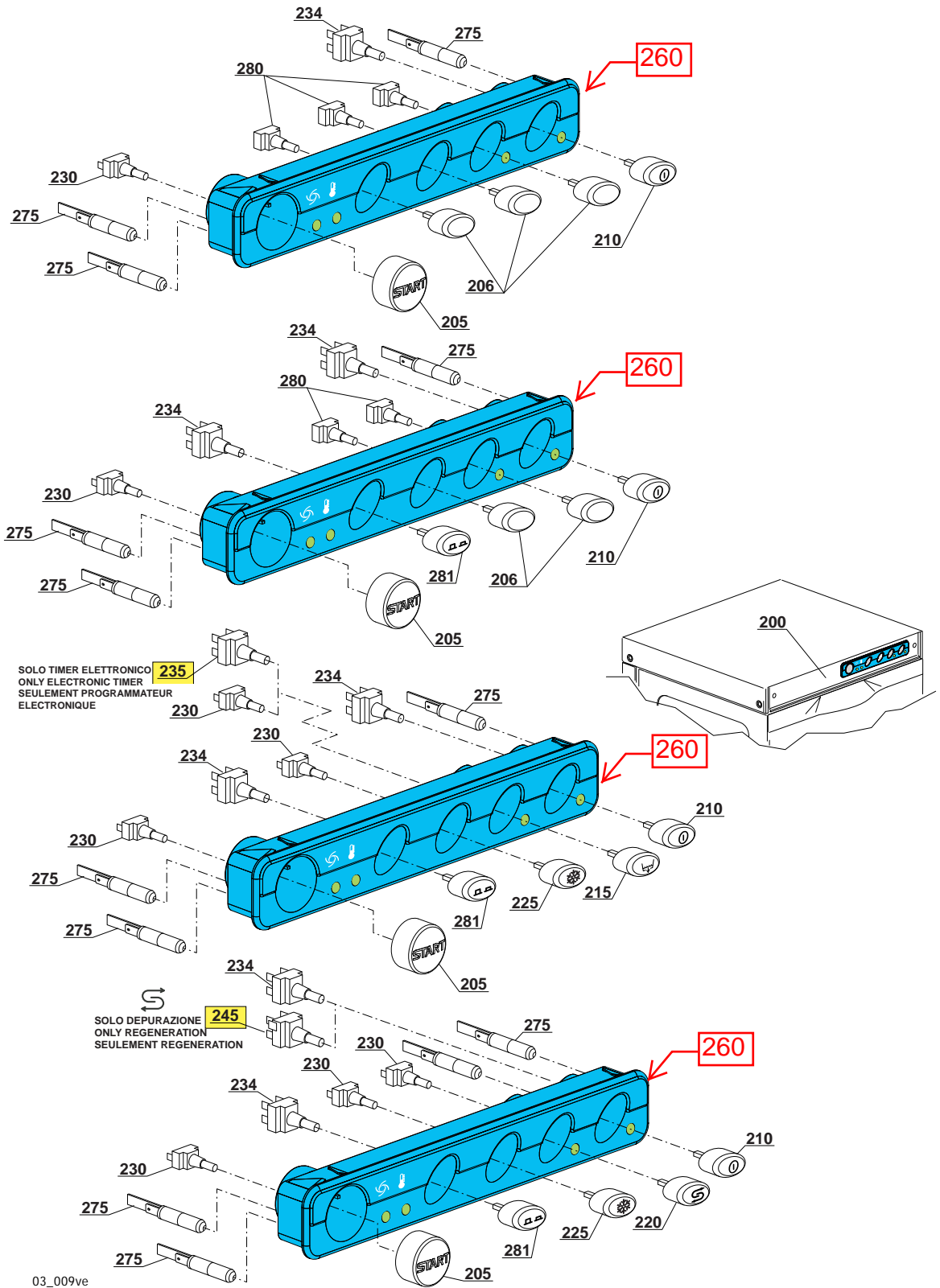

Spare parts

ID	P-code	SN from	SN to	Mod.	Acces.	Volt	Description
Module:Control panel and switches							
200	500953		-	em			Control panel my 2014
205	89847		-	em			Start prush button
206	89848		-	em			Blind push button
210	89840		-	em			ON-OFF prush button
215	89843		-	em	dp		Drain pump prush button
220	89845		-	em	ws		Regeneration prush button
225	89844		-	em	cr		Hot/cold prush button
230	15813		-	em			16A unipolar switch
234	15812		-	em			16A bipolar switch
235	15800		-	em			16A push button
245	15811		-	em			16A bipolar switch
260	89362		-	em			my 2014 five holes control panel
275	15826		-	em			Pilot light 220V
280	15844		-	em			Push button support
281	89842		-	em			Time selector switch push button

9U=9U

dvgw=DVGW, cr=COLD RINSE, ws=WATER SOFTNER, dd=DETERGENT DISPENSER, dp=DRAIN PUMP

A=3/N/PE~380-400V 50-60Hz, D=3/PE~200-210V 50-60Hz, F=2/PE~220-240V 50-60Hz, G=3/N/PE~415V 50-60Hz, H=3/PE~220-230V 50-60Hz, K=3/PE~380-400V 50-60Hz, L=3/PE~415V 50-60Hz, M=3/PE~440V 60Hz, P=1/N/PE~220-230V 50-60Hz, R=2/PE~220-240V 50-60Hz, U=1/N/PE~240V 50-60Hz, V=3/PE~240V 50-60Hz, W=1/N/PE~100-110V 50-60Hz

Spare parts

2 TEMPI DEPURAZIONE
2 PROGRAMS REGENERATION

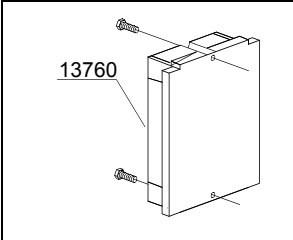

2 TEMPI POMPA SCARICO
2 PROGRAMS DRAIN PUMP

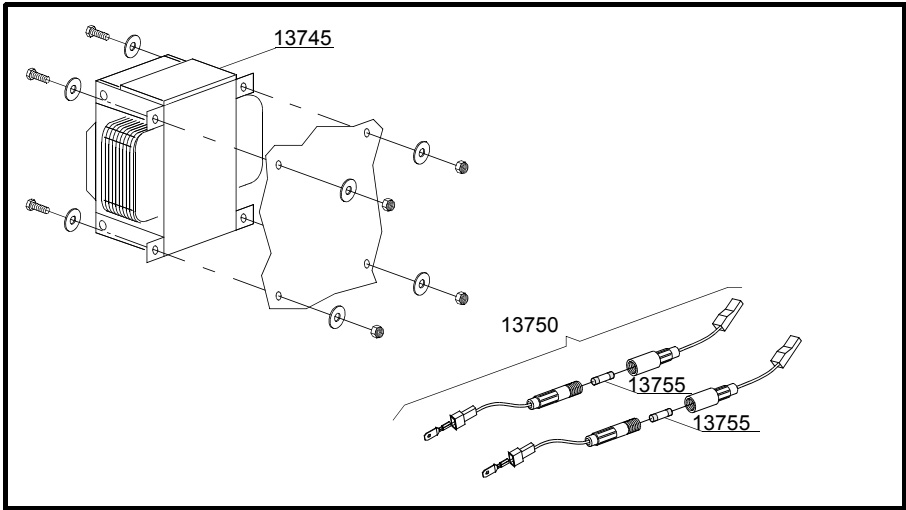
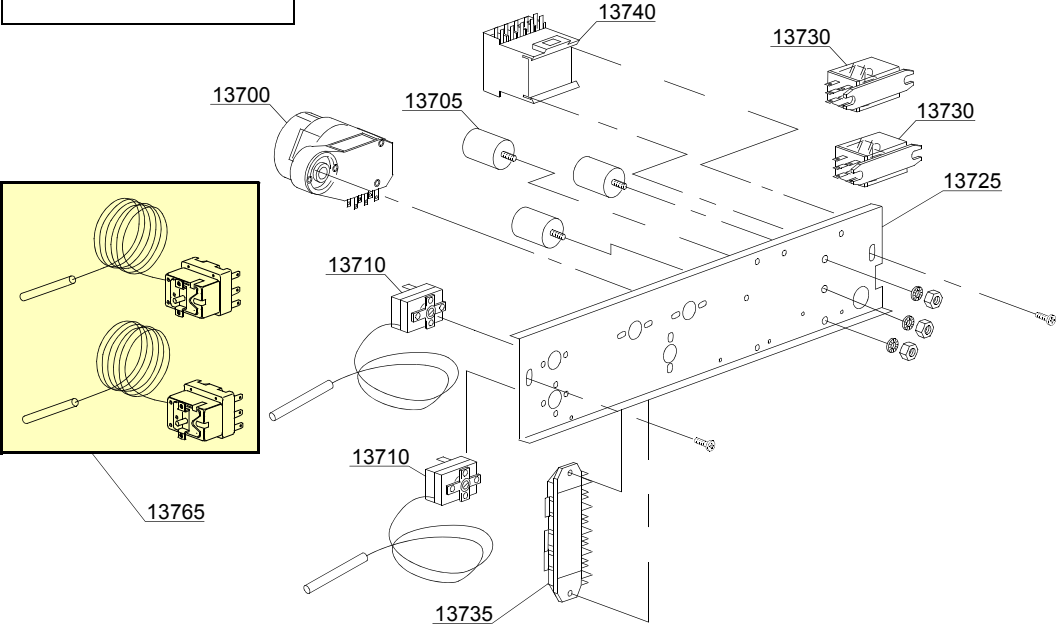
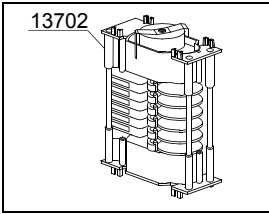

04_013_e

Spare parts

ID	P-code	SN from	SN to	Mod.	Acces.	Volt	Description
Module:Electric control components							
13700	10708/L		-	em		A	120" timer - 230Vac 50Hz
13700	10708/B		-	em			120" timer - 220Vac 60Hz
13700	10708/E		-	em			120" timer with thermostop - 110Vac 60Hz
13700	10708/T		-	em			Timer 120" with thermostop - 230Vac 50Hz
13702	30001027		-	em		A	120/180s timer - 230Vac 50Hz
13702	30001030		-	em		A	120/180s timer - 230Vac 50Hz with TERMOSTOP
13702	30001031		-	em	dp	A	120/180" timer with thermostop and drain pump
13705	15149		-	em			Low noise filter F3 0,33 mF
13705	15187		-	em			Low noise filter F3 440 VaC 3
13710	10707/1		-	em			0-90°C thermostat
13725	500910		-	em			Electric components panel
13730	15620		-	em	dp		16A bipolar relay in deviation
13730	15620/A		-	em			Bipolar relay in deviation - 110Vac 60Hz
13735	500550		-	em			3 poles terminal board
13735	500551		-	em			6 poles terminal board
13740	15086		-	em			Contactora 230V 50/60Hz 4C
13740	10300055		-	em			25A 110Vac 50/60Hz contactor
13745	15381		-	em			160Va transformer 0-230-400-415-440/230V
13750	15147		-	em			Fuse-holder
13755	15163		-	em			Fuse (minimum 5 pieces)
13760	50553		-	em	ws		3 times electronic timer with regeneration
13760	50553/W		-	em	ws		3 times electronic timer with regeneration (WRAS)
13765	15553		-	em			Security Thermostat (EGO) 110°C 3 poles

em=ELECTROMECHANICAL SWITCHES, uw=LOWER AND UPPER WASHING

9U=9U

bt=BREAK TANK, bp=BOOSTER PUMP, dvgw=DVGW, cr=COLD RINSE, ws=WATER SOFTNER, dd=DETERGENT DISPENSER, dp=DRAIN PUMP

A=3/N/PE~380-400V 50-60Hz, D=3/PE~200-210V 50-60Hz, F=2/PE~220-240V 50-60Hz, G=3/N/PE~415V 50-60Hz, H=3/PE~220-230V 50-60Hz, K=3/PE~380-400V 50-60Hz, L=3/PE~415V 50-60Hz, M=3/PE~440V 60Hz, P=1/N/PE~220-230V 50-60Hz, R=2/PE~220-240V 50-60Hz, U=1/N/PE~240V 50-60Hz, V=3/PE~240V 50-60Hz, W=1/N/PE~100-110V 50-60Hz

Spare parts

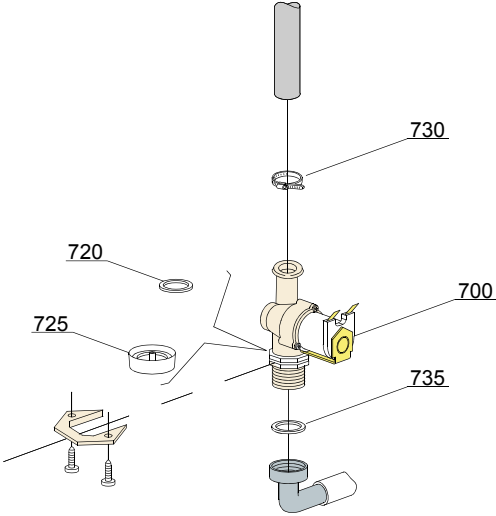

05_002_e

Spare parts

ID	P-code	SN from	SN to	Mod.	Acces.	Volt	Description
Module:Solenoid valve group							
700	10703		-	em			Single solenoid valve - 230Vac
700	10703/A		-	em			Single solenoid valve - 110Vac
720	N.C.		-	em			Pression reducing valve
730	11807		-	em			12/22 clamp (minimum 3 pieces)
735	13307		-	em			3/4 gasket

em=ELECTROMECHANICAL SWITCHES, uw=LOWER AND UPPER WASHING

9U=9U

bt=BREAK TANK, bp=BOOSTER PUMP, dvgw=DVGW, cr=COLD RINSE, ws=WATER SOFTNER, dd=DETERGENT DISPENSER, dp=DRAIN PUMP

A=3/N/PE~380-400V 50-60Hz, D=3/PE~200-210V 50-60Hz, F=2/PE~220-240V 50-60Hz, G=3/N/PE~415V 50-60Hz, H=3/PE~220-230V 50-60Hz, K=3/PE~380-400V 50-60Hz, L=3/PE~415V 50-60Hz, M=3/PE~440V 60Hz, P=1/N/PE~220-230V 50-60Hz, R=2/PE~220-240V 50-60Hz, U=1/N/PE~240V 50-60Hz, V=3/PE~240V 50-60Hz, W=1/N/PE~100-110V 50-60Hz

Spare parts

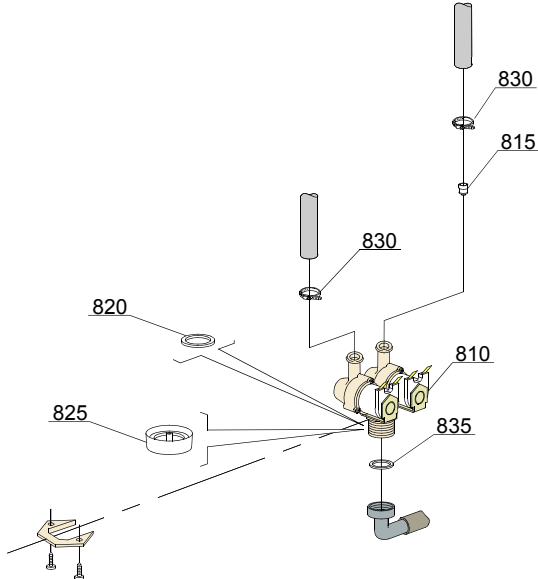

05_003_e

Spare parts

ID	P-code	SN from	SN to	Mod.	Acces.	Volt	Description
Module:Solenoid valve group							
810	15098		-	em	cr,ws		Double solenoid valve - Ø10 - 230Vac
815	15115		-	em	cr,ws		Green pression solenoid valve for regeneration (minimum 2 pieces)
820	N.C.		-	em	cr,ws		Pression reducing valve
830	11807		-	em			12/22 clamp (minimum 3 pieces)
835	13307		-	em			3/4 gasket

em=ELECTROMECHANICAL SWITCHES, uw=LOWER AND UPPER WASHING

9U=9U

bt=BREAK TANK, bp=BOOSTER PUMP, dvgw=DVGW, cr=COLD RINSE, ws=WATER SOFTNER, dd=DETERGENT DISPENSER, dp=DRAIN PUMP

A=3/N/PE~380-400V 50-60Hz, D=3/PE~200-210V 50-60Hz, F=2/PE~220-240V 50-60Hz, G=3/N/PE~415V 50-60Hz, H=3/PE~220-230V 50-60Hz, K=3/PE~380-400V 50-60Hz, L=3/PE~415V 50-60Hz, M=3/PE~440V 60Hz, P=1/N/PE~220-230V 50-60Hz, R=2/PE~220-240V 50-60Hz, U=1/N/PE~240V 50-60Hz, V=3/PE~240V 50-60Hz, W=1/N/PE~100-110V 50-60Hz

Spare parts

06_004pe

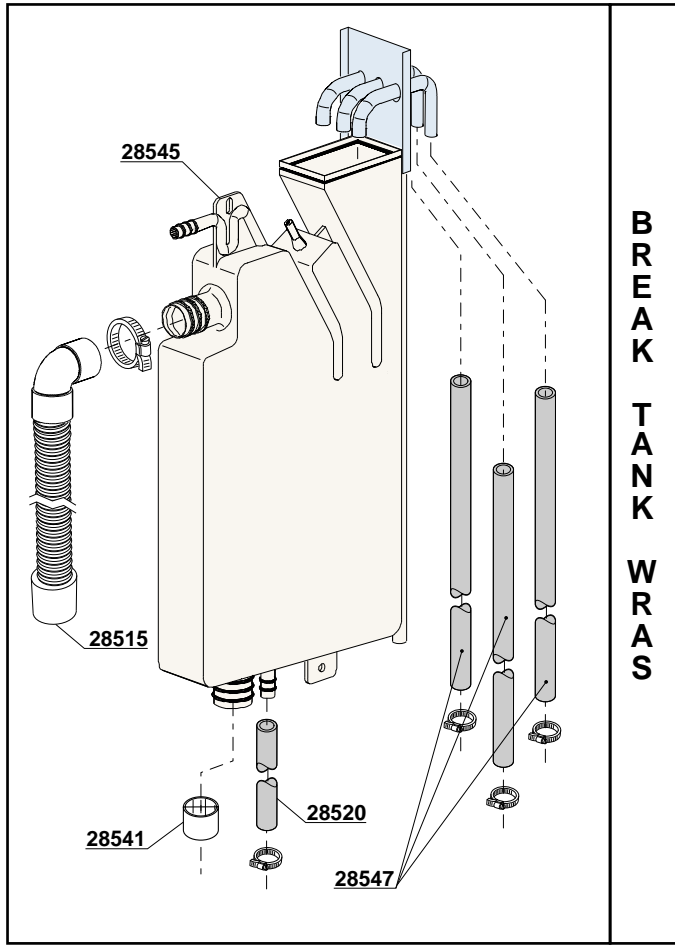
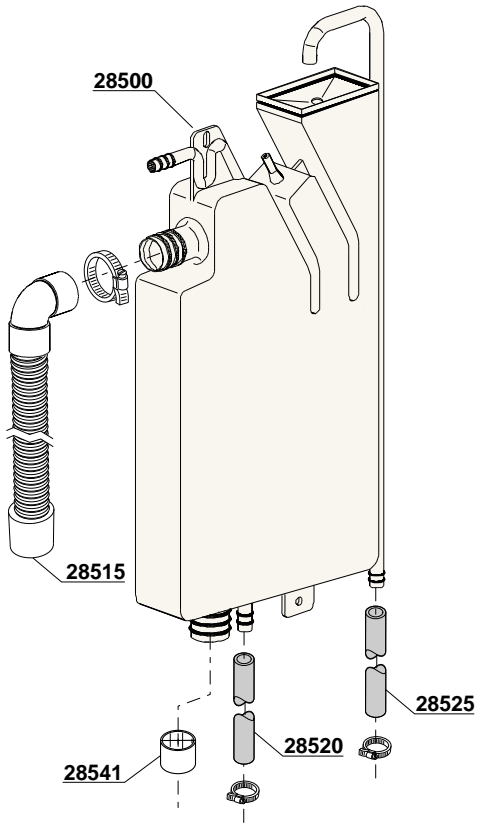

B
R
E
A
K

T
A
N
K

W
R
A
S

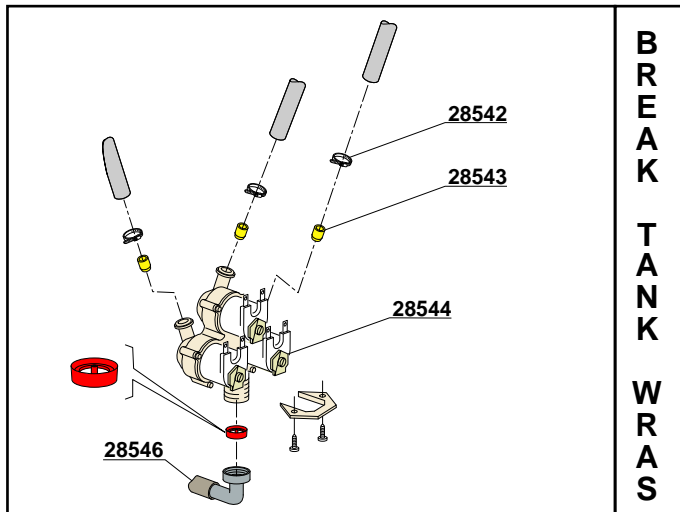
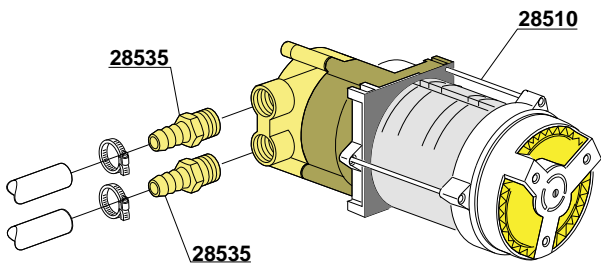
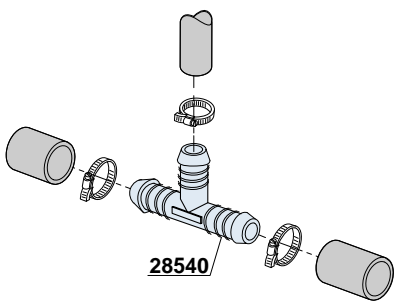
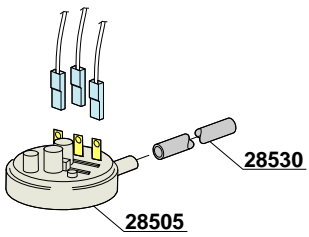

B
R
E
A
K

T
A
N
K

W
R
A
S

Spare parts

ID	P-code	SN from	SN to	Mod.	Acces.	Volt	Description
Module:Break Tank & Break Tank WRAS							
28500	15735		-	i,em	bt		Break tank assembly
28505	10706/A		-	i,em	bt		46-26 pressure switch
28510	15100/D		-	i,em	bt		Booster pump 220/240V - body pumps in brass
28515	15722		-	i,em	bt		BT middle pipe L=920mm
28520	2907350		-	i,em	bt		12x20 EPDM rubber hose
28525	2907352		-	i,em	bt		PVC WRAS rubber hose
28530	14508		-	i,em	bt		4,5x9 EPDM rubber hose (minimum 2 mt)
28535	10221311		-	i,em	bt		Rubber holder Ø 12 3/8G
28540	540098		-	i,em	bt		3 ways D25
28541	12533		-	i,em	bt		Reinforce for pipe in exit (break rank)
28542	11800		-	i,em	bt		8/16 Clamp
28543	15115/G		-	i,em	bt		Yellow outlet flow regulator
28544	15099		-	i,em	bt		Triple solenoid valve
28545	15735/W3		-	i,em	bt		Break Tank assembly WRAS
28546	10726		-	i,em	bt		Wras load pipe
28547	2907352		-	i,em	bt		Rubber pipe for WRAS Break Tank

A=3/N/PE~380-400V 50-60Hz, D=3/PE~200-210V 50-60Hz, F=2/PE~220-240V 50-60Hz, G=3/N/PE~415V 50-60Hz, H=3/PE~220-230V 50-60Hz, K=3/PE~380-400V 50-60Hz, L=3/PE~415V 50-60Hz, M=3/PE~440V 60Hz, P=1/N/PE~220-230V 50-60Hz, R=2/PE~220-240V 50-60Hz, U=1/N/PE~240V 50-60Hz, V=3/PE~240V 50-60Hz, W=1/N/PE~100-110V 50-60Hz

Spare parts

07_003ae

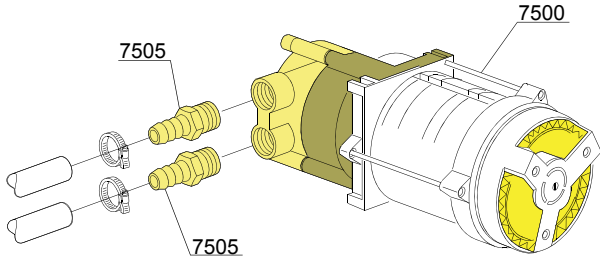

VERSIONE STANDARD / VERSIONE POMPA AUM. PRESSIONE
STANDARD VERSION / BOOSTER PUMP VERSION
VERSION STANDARD / VERSION POMPE AUGMENT. PRESSION

Spare parts

ID	P-code	SN from	SN to	Mod.	Acces.	Volt	Description
Module:Booster pump							
7500	15100/D		-	em	bp		Booster pump 220/240V - body pumps in plastic
7505	10221311		-	em	bp		Rubber holder Ø 12 3/8G

em=ELECTROMECHANICAL SWITCHES, uw=LOWER AND UPPER WASHING

9U=9U

bt=BREAK TANK, bp=BOOSTER PUMP, dvgw=DVGW, cr=COLD RINSE, ws=WATER SOFTNER, dd=DETERGENT DISPENSER, dp=DRAIN PUMP

A=3/N/PE~380-400V 50-60Hz, D=3/PE~200-210V 50-60Hz, F=2/PE~220-240V 50-60Hz, G=3/N/PE~415V 50-60Hz, H=3/PE~220-230V 50-60Hz, K=3/PE~380-400V 50-60Hz, L=3/PE~415V 50-60Hz, M=3/PE~440V 60Hz, P=1/N/PE~220-230V 50-60Hz, R=2/PE~220-240V 50-60Hz, U=1/N/PE~240V 50-60Hz, V=3/PE~240V 50-60Hz, W=1/N/PE~100-110V 50-60Hz

Spare parts

08_005_e

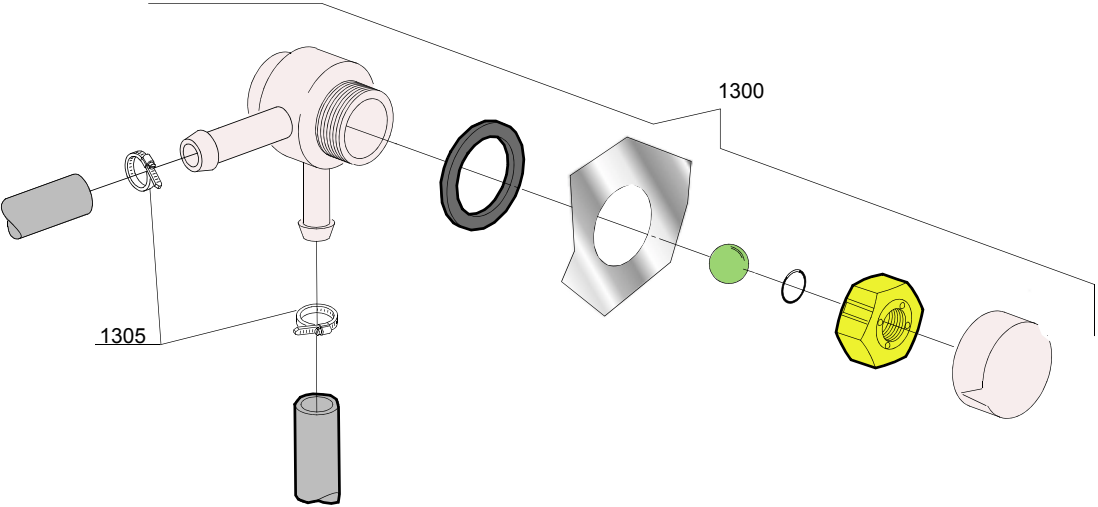

Spare parts

ID	P-code	SN from	SN to	Mod.	Acces.	Volt	Description
Module:DVGW							
1300	99900006		-	em	dvgw		DVGW assembly
1305	11807		-	em	dvgw		12/22 clamp (minimum 3 pieces)

em=ELECTROMECHANICAL SWITCHES, uw=LOWER AND UPPER WASHING

9U=9U

bt=BREAK TANK, bp=BOOSTER PUMP, dvgw=DVGW, cr=COLD RINSE, ws=WATER SOFTNER, dd=DETERGENT DISPENSER, dp=DRAIN PUMP

A=3/N/PE~380-400V 50-60Hz, D=3/PE~200-210V 50-60Hz, F=2/PE~220-240V 50-60Hz, G=3/N/PE~415V 50-60Hz, H=3/PE~220-230V 50-60Hz, K=3/PE~380-400V 50-60Hz, L=3/PE~415V 50-60Hz, M=3/PE~440V 60Hz, P=1/N/PE~220-230V 50-60Hz, R=2/PE~220-240V 50-60Hz, U=1/N/PE~240V 50-60Hz, V=3/PE~240V 50-60Hz, W=1/N/PE~100-110V 50-60Hz

Spare parts

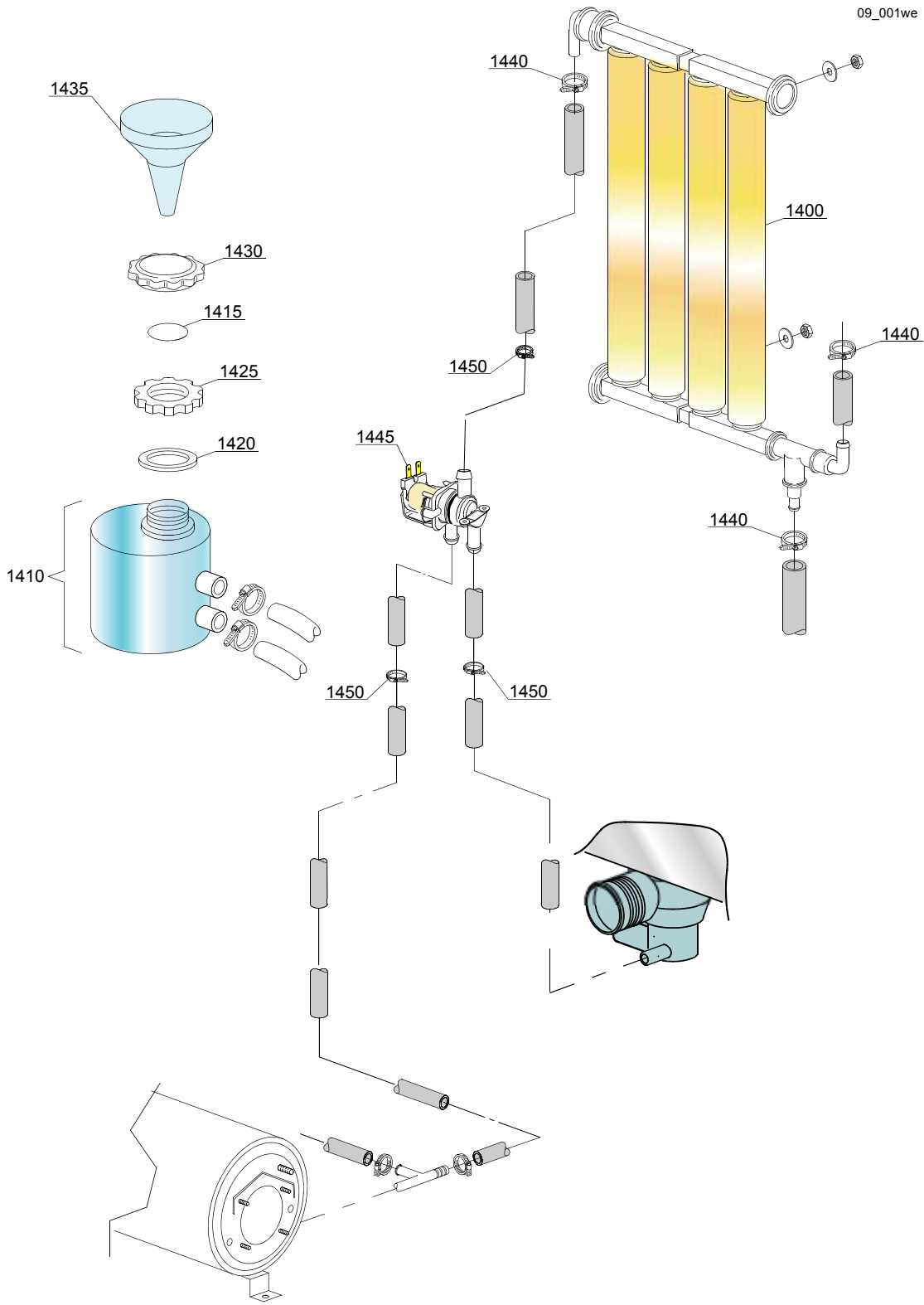

Spare parts

ID	P-code	SN from	SN to	Mod.	Acces.	Volt	Description
Module:Water softner group							
1400	16066		-	em	ws		4 elements water softner
1410	16065		-	em	ws		Salt container
1415	16067/A		-	em	ws		OR O-ring
1420	16067/B		-	em	ws		O-ring
1425	16067/C		-	em	ws		Ring nut
1430	16067/D		-	em	ws		Plug
1435	16082		-	em	ws		Funnel
1440	11807		-	em	ws		12/22 clamp (minimum 3 pieces)
1445	15213		-	em	ws		1xNA-1xNO 220/240V - 50/60Hz single solenoid valve
1450	11800		-	em	ws		8/16 clamp (minimum 3 pieces)

em=ELECTROMECHANICAL SWITCHES, uw=LOWER AND UPPER WASHING

9U=9U

bt=BREAK TANK, bp=BOOSTER PUMP, dvgw=DVGW, cr=COLD RINSE, ws=WATER SOFTNER, dd=DETERGENT DISPENSER, dp=DRAIN PUMP

A=3/N/PE~380-400V 50-60Hz, D=3/PE~200-210V 50-60Hz, F=2/PE~220-240V 50-60Hz, G=3/N/PE~415V 50-60Hz, H=3/PE~220-230V 50-60Hz, K=3/PE~380-400V 50-60Hz, L=3/PE~415V 50-60Hz, M=3/PE~440V 60Hz, P=1/N/PE~220-230V 50-60Hz, R=2/PE~220-240V 50-60Hz, U=1/N/PE~240V 50-60Hz, V=3/PE~240V 50-60Hz, W=1/N/PE~100-110V 50-60Hz

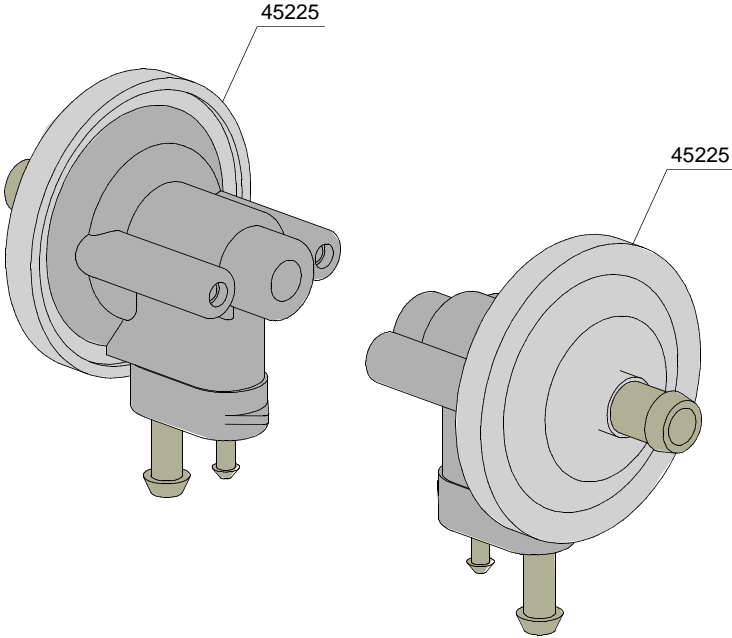
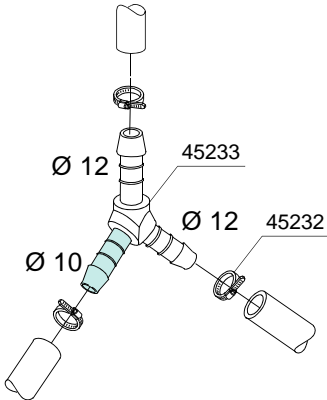

Spare parts

ID	P-code	SN from	SN to	Mod.	Acces.	Volt	Description
Module: Rinse aid dispenser group							
45225	10799/G		-	e			GERMAC rinse aid dispenser
45232	11807		-	e			Clamp 12/22 (min. 3 pz)
45233	540104		-	e			Plastic 3 ways connection Ø 12-12-10mm

i=INSULATED HOOD, e=ELECTRONICAL CONTROL

1

lift=HOOD LIFTING SYSTEM, bt=BREAK TANK, bp=BOOSTER PUMP, dvgw=DVGW, ws=WATER SOFTNER, dd=DETERGENT DISPENSER, dp=DRAIN PUMP

A=3/N/PE~380-400V 50-60Hz, D=3/PE~200-210V 50-60Hz, F=2/PE~220-240V 50-60Hz, G=3/N/PE~415V 50-60Hz, H=3/PE~220-230V 50-60Hz, K=3/PE~380-400V 50-60Hz, L=3/PE~415V 50-60Hz, M=3/PE~440V 60Hz, P=1/N/PE~220-230V 50-60Hz, R=2/PE~220-240V 50-60Hz, U=1/N/PE~240V 50-60Hz, V=3/PE~240V 50-60Hz, W=1/N/PE~100-110V 50-60Hz

Spare parts

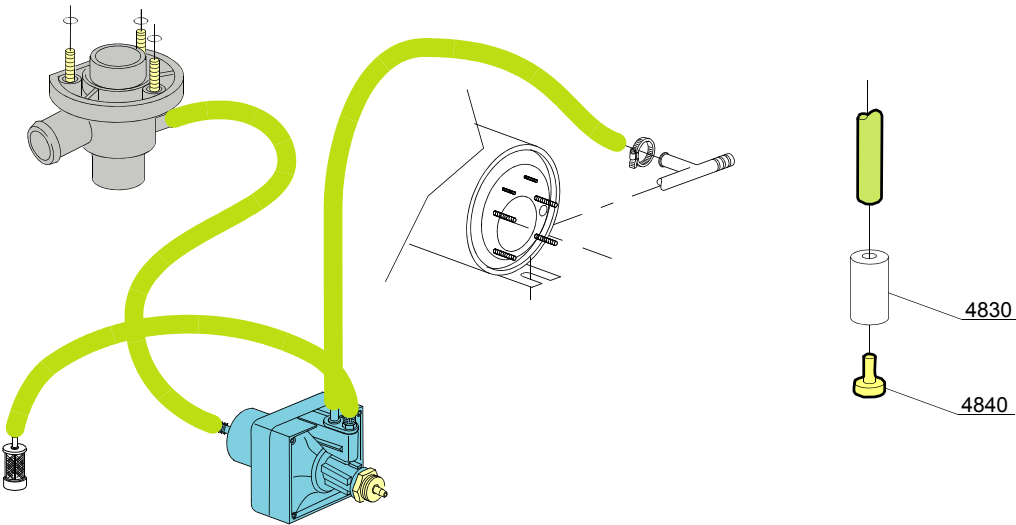
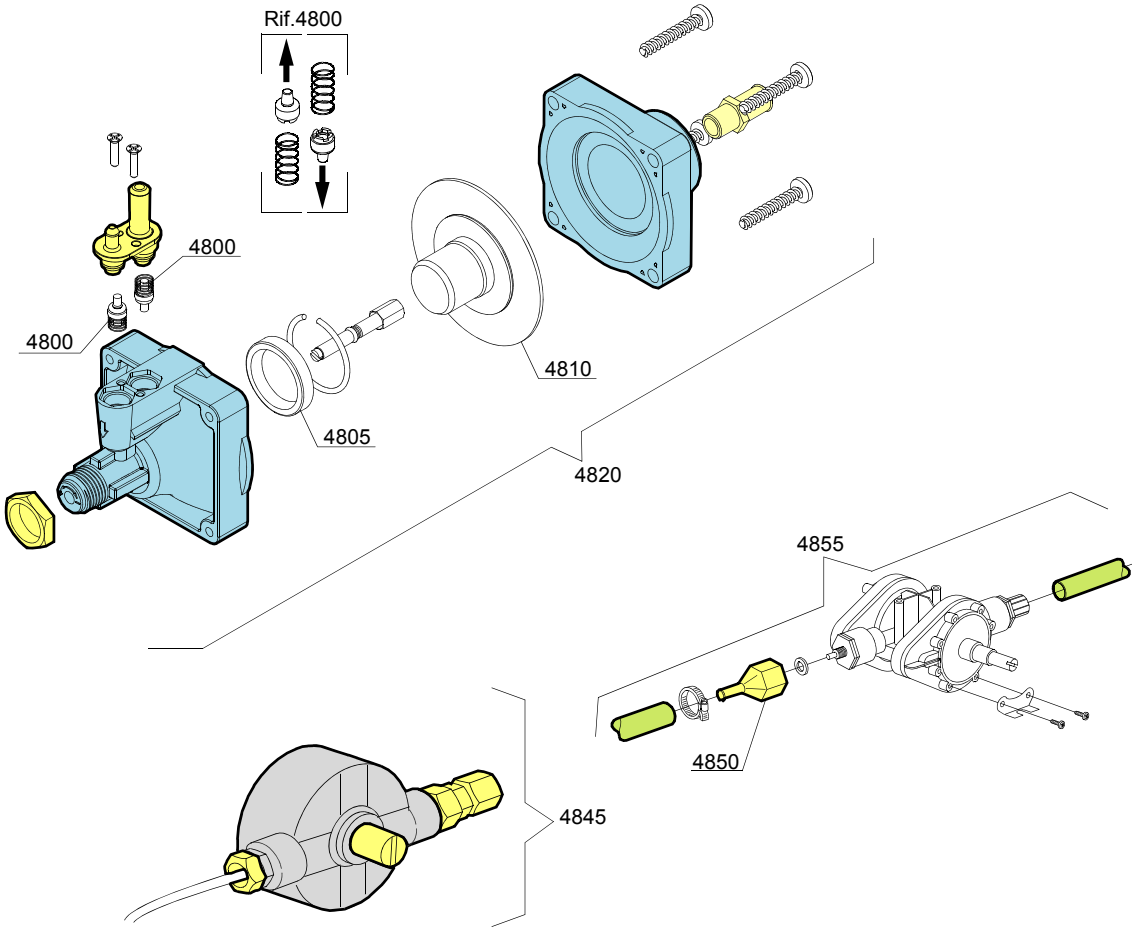

10_004_e

Spare parts

ID	P-code	SN from	SN to	Mod.	Acces.	Volt	Description
Module: Rinse aid dispenser group							
4800	10805		-	em			Tecnopro non return valve
4805	10806		-	em			Ø22 O-ring
4810	10807		-	em			Membrane
4820	10799		-	em			TECNO PRO rinse aid dispenser
4830	12525		-	em			Ballast
4840	15058		-	em			Small filter (minimum 3 pieces)
4845	10799/G		-	em			GERMAC rinse aid dispenser
4850	10798/B		-	em			Brass pipe fitting
4855	10798		-	em			LANG rinse aid dispenser

em=ELECTROMECHANICAL SWITCHES, uw=LOWER AND UPPER WASHING

9U=9U

bt=BREAK TANK, bp=BOOSTER PUMP, dvgw=DVGW, cr=COLD RINSE, ws=WATER SOFTNER, dd=DETERGENT DISPENSER, dp=DRAIN PUMP

A=3/N/PE~380-400V 50-60Hz, D=3/PE~200-210V 50-60Hz, F=2/PE~220-240V 50-60Hz, G=3/N/PE~415V 50-60Hz, H=3/PE~220-230V 50-60Hz, K=3/PE~380-400V 50-60Hz, L=3/PE~415V 50-60Hz, M=3/PE~440V 60Hz, P=1/N/PE~220-230V 50-60Hz, R=2/PE~220-240V 50-60Hz, U=1/N/PE~240V 50-60Hz, V=3/PE~240V 50-60Hz, W=1/N/PE~100-110V 50-60Hz

11_002_e

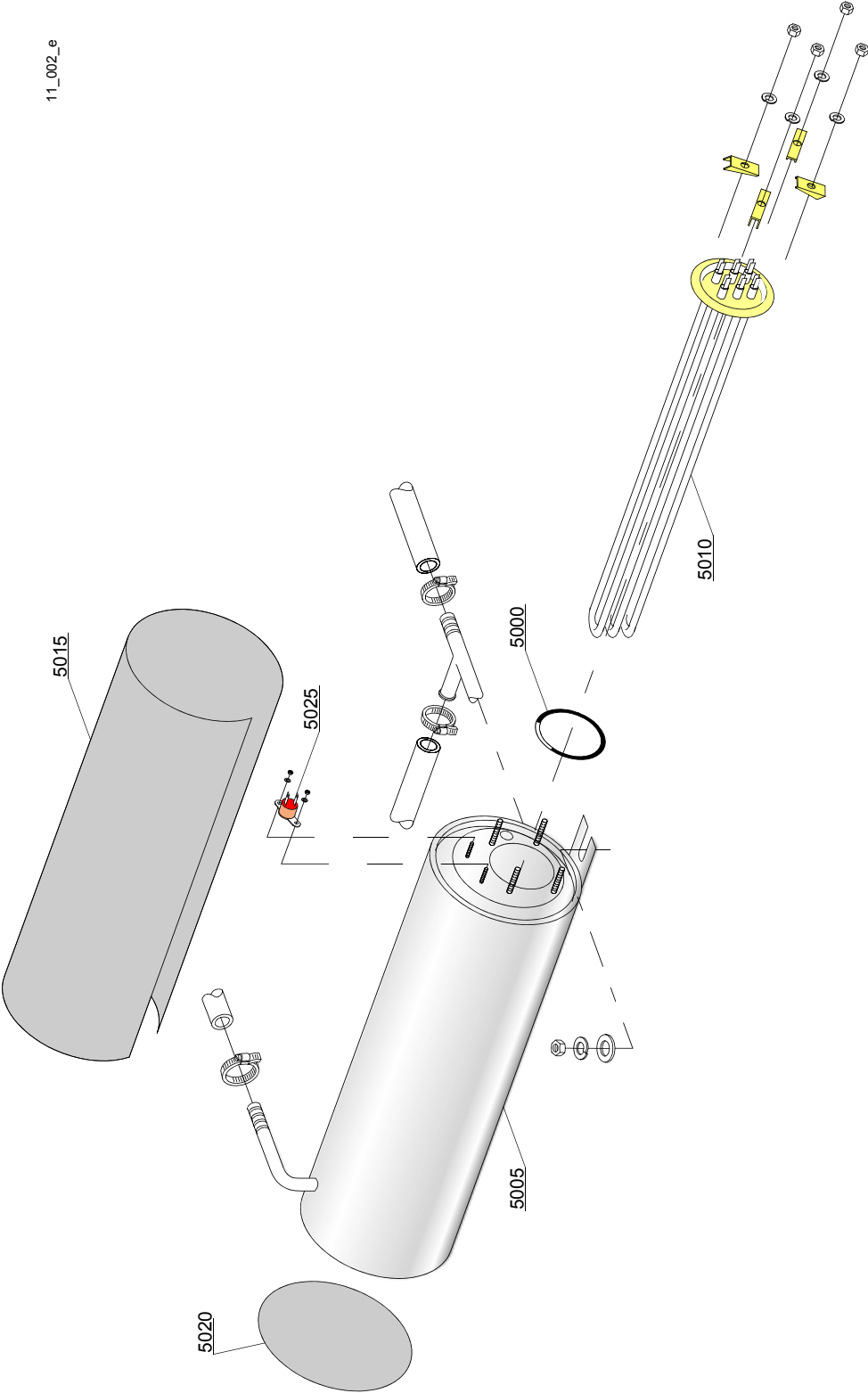

Spare parts

ID	P-code	SN from	SN to	Mod.	Acces.	Volt	Description
Module:Boiler group							
5000	13005		-	em			OR 151 NBR O-ring (minimum 5 pieces)
5005	150905		-	em			Boiler
5010	15089		-	em			4,5/4,9KW 230/240V 3 heating element
5010	15089/B		-	em			4,5KW heating element - 254/440Vac
5010	15089/C		-	em			3,5KW - 110V heating element
5010	15089/D		-	em			2,8/3,05KW - 230/240V heating element
5010	15089/E		-	em			6/6,53KW - 230/240V 3 heating element
5015	15066		-	em			Insulation boiler
5020	15205		-	em			Ø160 End piece (minimum 2 pieces)
5025	15550		-	em			Safety thermostat

em=ELECTROMECHANICAL SWITCHES, uw=LOWER AND UPPER WASHING

9U=9U

bt=BREAK TANK, bp=BOOSTER PUMP, dvgw=DVGW, cr=COLD RINSE, ws=WATER SOFTNER, dd=DETERGENT DISPENSER, dp=DRAIN PUMP

A=3/N/PE~380-400V 50-60Hz, D=3/PE~200-210V 50-60Hz, F=2/PE~220-240V 50-60Hz, G=3/N/PE~415V 50-60Hz, H=3/PE~220-230V 50-60Hz, K=3/PE~380-400V 50-60Hz, L=3/PE~415V 50-60Hz, M=3/PE~440V 60Hz, P=1/N/PE~220-230V 50-60Hz, R=2/PE~220-240V 50-60Hz, U=1/N/PE~240V 50-60Hz, V=3/PE~240V 50-60Hz, W=1/N/PE~100-110V 50-60Hz

Spare parts

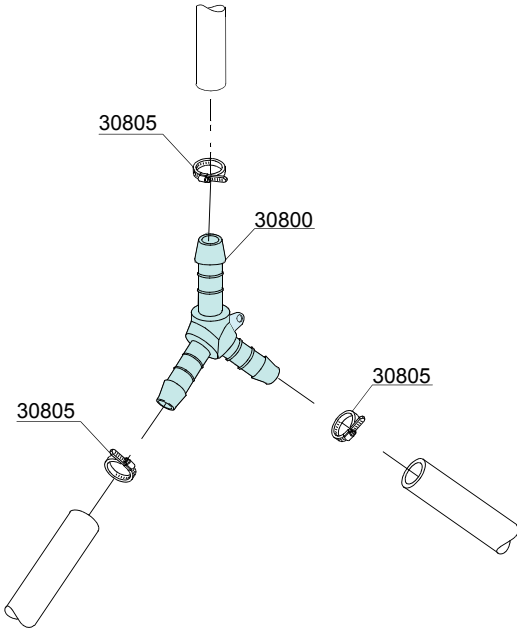

12_003pe

Spare parts

ID	P-code	SN from	SN to	Mod.	Acces.	Volt	Description
Module:3 ways connection							
30800	540091		-	em			Ø12 mm plastic 3 ways connection
30805	11807		-	em			12/22 clamp (minimum 3 pieces)

em=ELECTROMECHANICAL SWITCHES, uw=LOWER AND UPPER WASHING

9U=9U

bt=BREAK TANK, bp=BOOSTER PUMP, dvgw=DVGW, cr=COLD RINSE, ws=WATER SOFTNER, dd=DETERGENT DISPENSER, dp=DRAIN PUMP

A=3/N/PE~380-400V 50-60Hz, D=3/PE~200-210V 50-60Hz, F=2/PE~220-240V 50-60Hz, G=3/N/PE~415V 50-60Hz, H=3/PE~220-230V 50-60Hz, K=3/PE~380-400V 50-60Hz, L=3/PE~415V 50-60Hz, M=3/PE~440V 60Hz, P=1/N/PE~220-230V 50-60Hz, R=2/PE~220-240V 50-60Hz, U=1/N/PE~240V 50-60Hz, V=3/PE~240V 50-60Hz, W=1/N/PE~100-110V 50-60Hz

Spare parts

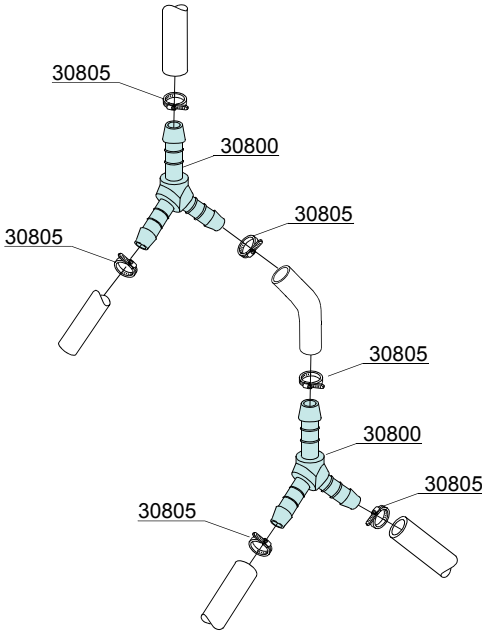

12_010pe

Spare parts

ID	P-code	SN from	SN to	Mod.	Acces.	Volt	Description
Module:4 ways connection							
30800	540091		-	em	cr		Ø12 mm plastic 3 ways connection
30805	11807		-	em	cr		12/22 clamp (minimum 3 pieces)

em=ELECTROMECHANICAL SWITCHES, uw=LOWER AND UPPER WASHING

9U=9U

bt=BREAK TANK, bp=BOOSTER PUMP, dvgw=DVGW, cr=COLD RINSE, ws=WATER SOFTNER, dd=DETERGENT DISPENSER, dp=DRAIN PUMP

A=3/N/PE~380-400V 50-60Hz, D=3/PE~200-210V 50-60Hz, F=2/PE~220-240V 50-60Hz, G=3/N/PE~415V 50-60Hz, H=3/PE~220-230V 50-60Hz, K=3/PE~380-400V 50-60Hz, L=3/PE~415V 50-60Hz, M=3/PE~440V 60Hz, P=1/N/PE~220-230V 50-60Hz, R=2/PE~220-240V 50-60Hz, U=1/N/PE~240V 50-60Hz, V=3/PE~240V 50-60Hz, W=1/N/PE~100-110V 50-60Hz

Spare parts

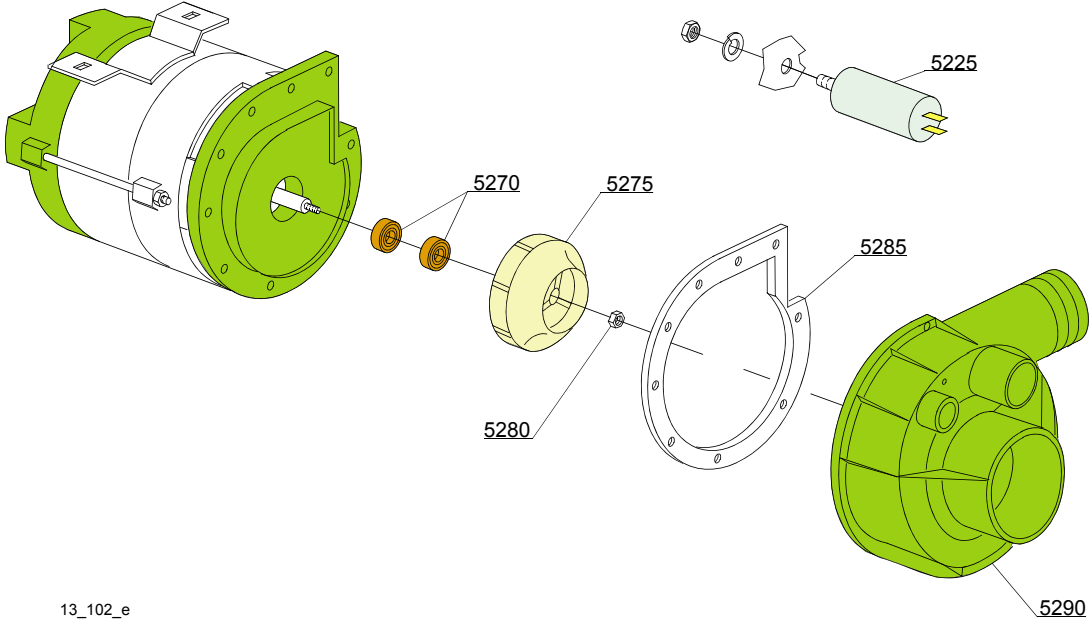
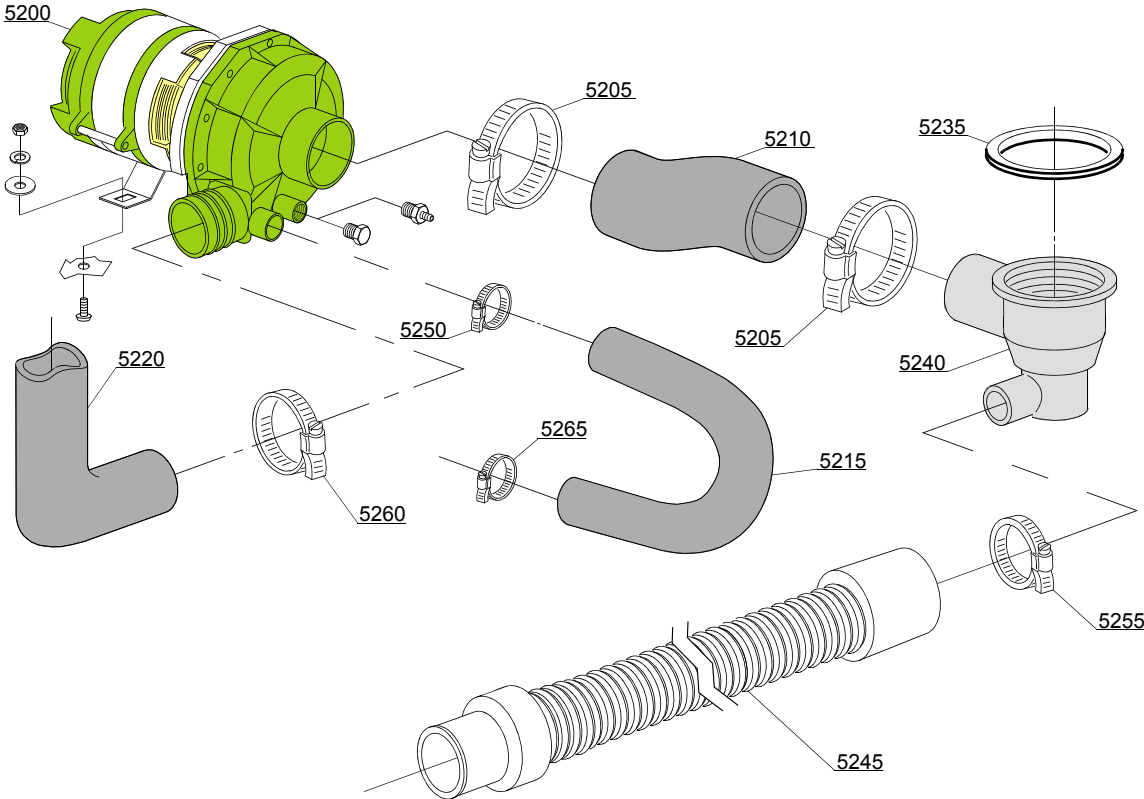

13_102_e

Spare parts

ID	P-code	SN from	SN to	Mod.	Acces.	Volt	Description
Module:Wash pump							
5200	15908/A		-	uw		A	0,75Hp wash pump - 220/240V 50Hz
5200	15908/P		-	uw			0,75Hp - 110Vac 60Hz wash pump
5200	15908/O		-	uw			0,75Hp - 200Vac 50Hz wash pump
5200	15908/D		-	uw			1Hp wash pump - 220/240Vac 50Hz
5200	15908/E		-	uw		A	0,75Hp wash pump - 440V/3/60Hz
5205	11824		-	uw			50/70 clamp (minimum 2 pieces)
5210	25032		-	uw			Suction pipe coupling
5215	560014		-	uw			Pump/lower wash turret delivery pipe
5220	560008		-	uw			Top delivery pipe
5225	15081		-	uw			12,5 uF condenser
5235	80208		-	uw			95x75x3 O-ring (minimum 2 pieces)
5240	500606		-	uw			Right side scrap tray
5245	10727		-	uw			Drain pipe
5250	11806		-	uw			25/40 clamp (minimum 2 pieces)
5255	11807		-	uw			12/22 clamp (minimum 3 pieces)
5260	11810		-	uw			40/60 clamp (minimum 2 pieces)
5265	11809		-	uw			30/45 clamp (minimum 2 pieces)
5270	15080/C		-	uw			Rotating seals
5270	15080		-	uw			Rotating seals (1HP)
5275	15079/B		-	uw			Pump rotor
5275	15912		-	uw			Pump rotor (1HP)
5280	11724		-	uw			M6 stainless steel nut
5285	15079/D		-	uw			O-ring
5290	15031/E		-	uw			Scroll

em=ELECTROMECHANICAL SWITCHES, uw=LOWER AND UPPER WASHING

9U=9U

bt=BREAK TANK, bp=BOOSTER PUMP, dvgw=DVGW, cr=COLD RINSE, ws=WATER SOFTNER, dd=DETERGENT DISPENSER, dp=DRAIN PUMP

A=3/N/PE~380-400V 50-60Hz, D=3/PE~200-210V 50-60Hz, F=2/PE~220-240V 50-60Hz, G=3/N/PE~415V 50-60Hz, H=3/PE~220-230V 50-60Hz, K=3/PE~380-400V 50-60Hz, L=3/PE~415V 50-60Hz, M=3/PE~440V 60Hz, P=1/N/PE~220-230V 50-60Hz, R=2/PE~220-240V 50-60Hz, U=1/N/PE~240V 50-60Hz, V=3/PE~240V 50-60Hz, W=1/N/PE~100-110V 50-60Hz

Spare parts

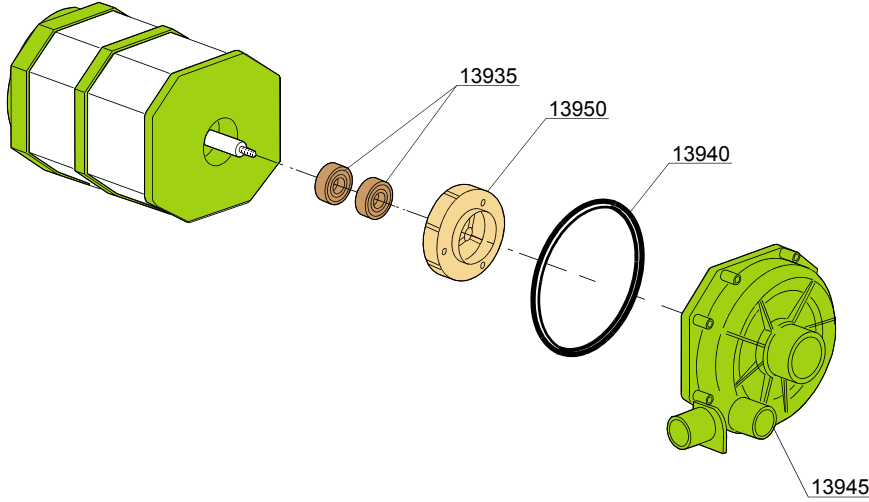
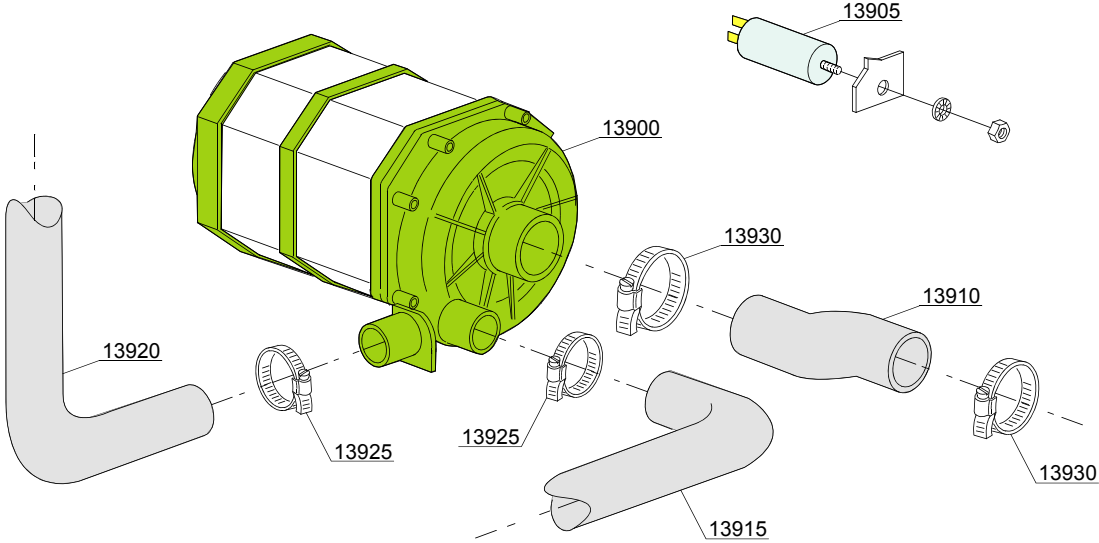

13_110_e

Spare parts

ID	P-code	SN from	SN to	Mod.	Acces.	Volt	Description
Module: Wash pump							
13900	150914		-	uw			0,70Hp wash pump - 230Vac 50Hz
13900	150915		-	uw			0,70Hp wash pump - 230Vac 60Hz
13905	15081		-	uw			12,5 uF condenser
13910	25032/A		-	uw			Suction pipe coupling
13915	150049		-	uw			Lower wash pipe coupling
13920	150048/A		-	uw			Wash ramp
13925	11806		-	uw			25/40 clamp (minimum 2 pieces)
13930	11809		-	uw			30/45 clamp (minimum 2 pieces)
13935	15080		-	uw			Rotating seals
13940	7130		-	uw			OR pump O-ring (minimum 2 pieces)
13945	16182		-	uw			Scroll
13950	15079/F		-	uw			Pump rotor

em=ELECTROMECHANICAL SWITCHES, uw=LOWER AND UPPER WASHING

9U=9U

bt=BREAK TANK, bp=BOOSTER PUMP, dvgw=DVGW, cr=COLD RINSE, ws=WATER SOFTNER, dd=DETERGENT DISPENSER, dp=DRAIN PUMP

A=3/N/PE~380-400V 50-60Hz, D=3/PE~200-210V 50-60Hz, F=2/PE~220-240V 50-60Hz, G=3/N/PE~415V 50-60Hz, H=3/PE~220-230V 50-60Hz, K=3/PE~380-400V 50-60Hz, L=3/PE~415V 50-60Hz, M=3/PE~440V 60Hz, P=1/N/PE~220-230V 50-60Hz, R=2/PE~220-240V 50-60Hz, U=1/N/PE~240V 50-60Hz, V=3/PE~240V 50-60Hz, W=1/N/PE~100-110V 50-60Hz

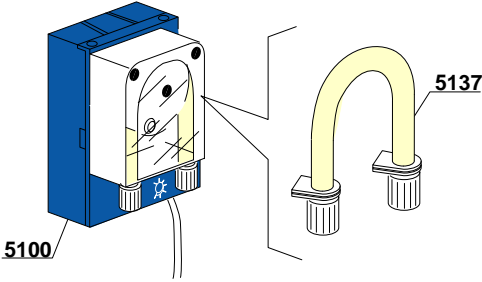
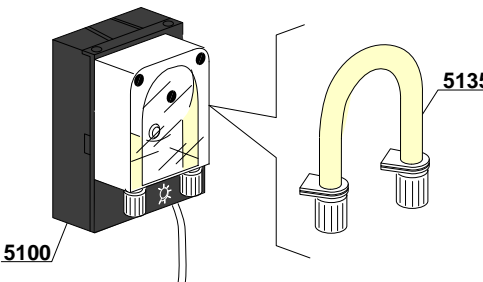
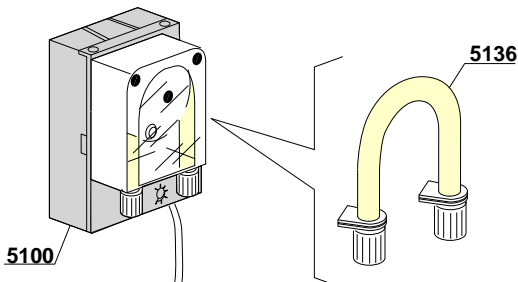
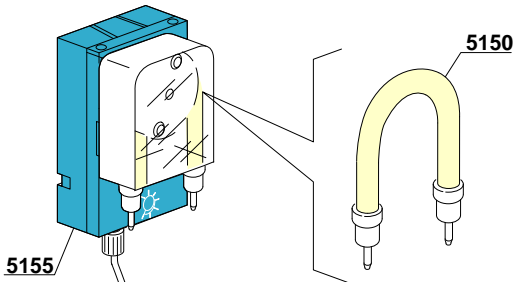
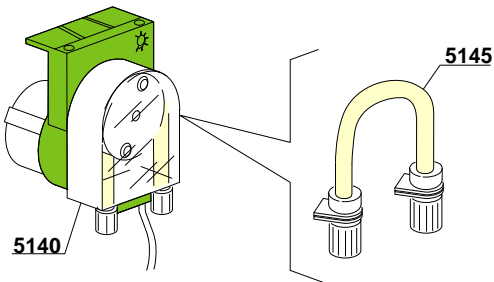
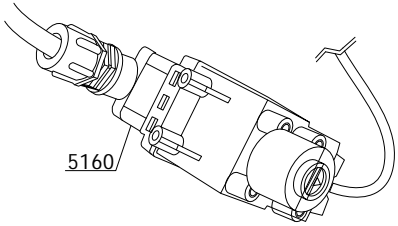
<p style="text-align: center;">SEKO</p> 	<p style="text-align: center;">SEKO</p> 
<p style="text-align: center;">TECNOPRO</p> 	<p style="text-align: center;">MICRODOS</p> 
<p style="text-align: center;">GERMAC</p> 	<p style="text-align: center;">LANG</p> 

14_004xe

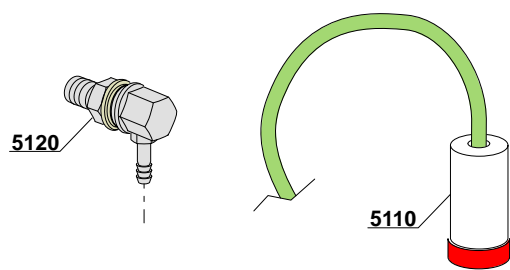

Spare parts

ID	P-code	SN from	SN to	Mod.	Acces.	Volt	Description
Module:Dosing detergent group							
5100	15985		-	i,e	dd		Seko detergent pump (black)
5100	15985		-	i,e	dd		Seko detergent pump (blue)
5100	15985		-	i,e	dd		Tecno Pro detergent pump
5110	15058		-	i,e	dd		Small filter (minimum 3 pieces)
5120	15123		-	i,e	dd		Compleat stainless steel injector
5135	15185		-	i,e	dd		Seko thermoplastic pipe (black)
5136	15297/T		-	,e	dd		Tecno Pro thermoplastic pipe
5137	15297		-	,e	dd		Seko thermoplastic pipe (blue)
5140	15985		-	i,e	dd		Germac detergent pump
5145	15108/E		-	i,e	dd		Germac thermoplastic pipe
5150	15985/A			i,e	dd		Micro Dos thermoplastic pipe
5155	15985			i,e	dd		Micro Dos detergent pump
5160	15108/L			i,e	dd		LANG detergent pump

Spare parts

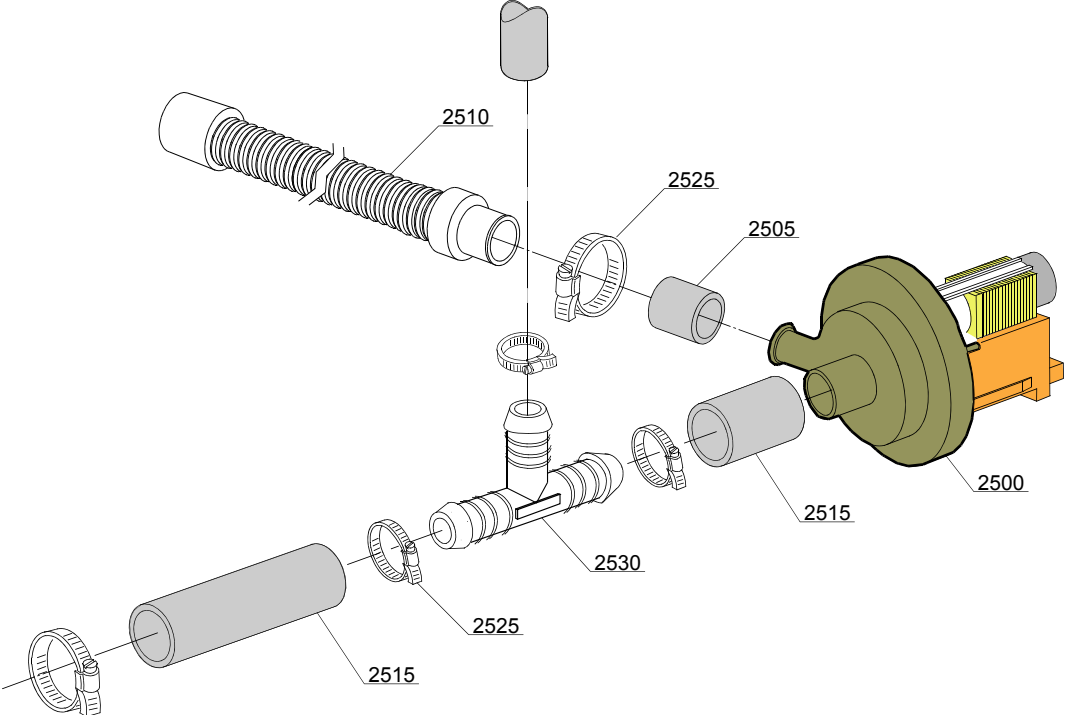

15_004be

Spare parts

ID	P-code	SN from	SN to	Mod.	Acces.	Volt	Description
Module:Drain pump group							
2500	15101		-	em	dp		Drain pump 220/240V 50Hz
2505	15101/D		-	em	dp		Pipe fitting (minimum 3 pieces)
2510	10727		-	em	dp		Drain pipe
2515	18044		-	em	dp		Ø28 top wash pipe
2525	11806		-	em	dp		25/40 clamp (minimum 2 pieces)
2530	540098		-	em	dp,bt		D25 3 ways connection for BREAK TANK(bt)

em=ELECTROMECHANICAL SWITCHES, uw=LOWER AND UPPER WASHING

9U=9U

bt=BREAK TANK, bp=BOOSTER PUMP, dvgw=DVGW, cr=COLD RINSE, ws=WATER SOFTNER, dd=DETERGENT DISPENSER, dp=DRAIN PUMP

A=3/N/PE~380-400V 50-60Hz, D=3/PE~200-210V 50-60Hz, F=2/PE~220-240V 50-60Hz, G=3/N/PE~415V 50-60Hz, H=3/PE~220-230V 50-60Hz, K=3/PE~380-400V 50-60Hz, L=3/PE~415V 50-60Hz, M=3/PE~440V 60Hz, P=1/N/PE~220-230V 50-60Hz, R=2/PE~220-240V 50-60Hz, U=1/N/PE~240V 50-60Hz, V=3/PE~240V 50-60Hz, W=1/N/PE~100-110V 50-60Hz

Spare parts

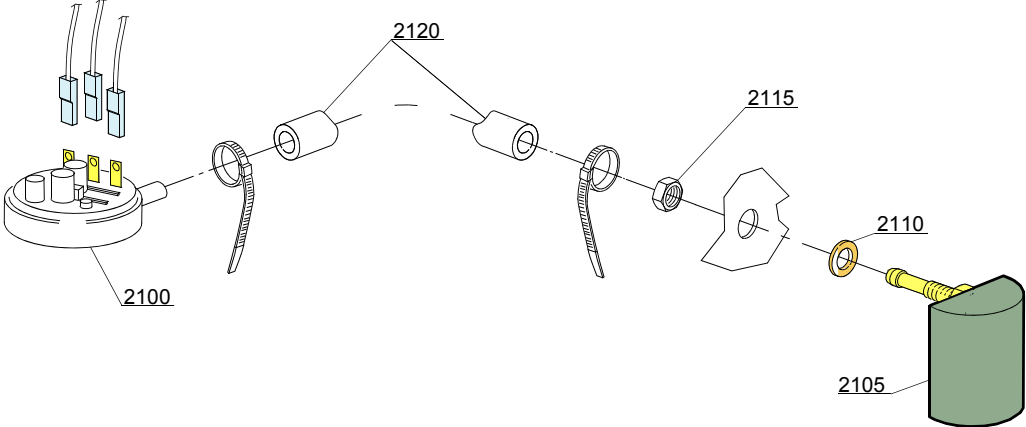

16_001_e

Spare parts

ID	P-code	SN from	SN to	Mod.	Acces.	Volt	Description
Module:Pressure switch group with air trap							
2100	10706/A		-	em			47-27 pressure switch
2105	135911/B	4020618	-	em			Grey air trap assembly
2110	13301		-	em			O-ring (minimum 10 pieces) - D14x8x1,5
2115	11702		-	em			M8 stainless steel nut (minimum 10 pieces)
2120	14508		-	em			4,5X9 EPDM rubber hose (minimum 2mt)

em=ELECTROMECHANICAL SWITCHES, uw=LOWER AND UPPER WASHING

9U=9U

bt=BREAK TANK, bp=BOOSTER PUMP, dvgw=DVGW, cr=COLD RINSE, ws=WATER SOFTNER, dd=DETERGENT DISPENSER, dp=DRAIN PUMP

A=3/N/PE~380-400V 50-60Hz, D=3/PE~200-210V 50-60Hz, F=2/PE~220-240V 50-60Hz, G=3/N/PE~415V 50-60Hz, H=3/PE~220-230V 50-60Hz, K=3/PE~380-400V 50-60Hz, L=3/PE~415V 50-60Hz, M=3/PE~440V 60Hz, P=1/N/PE~220-230V 50-60Hz, R=2/PE~220-240V 50-60Hz, U=1/N/PE~240V 50-60Hz, V=3/PE~240V 50-60Hz, W=1/N/PE~100-110V 50-60Hz

Spare parts

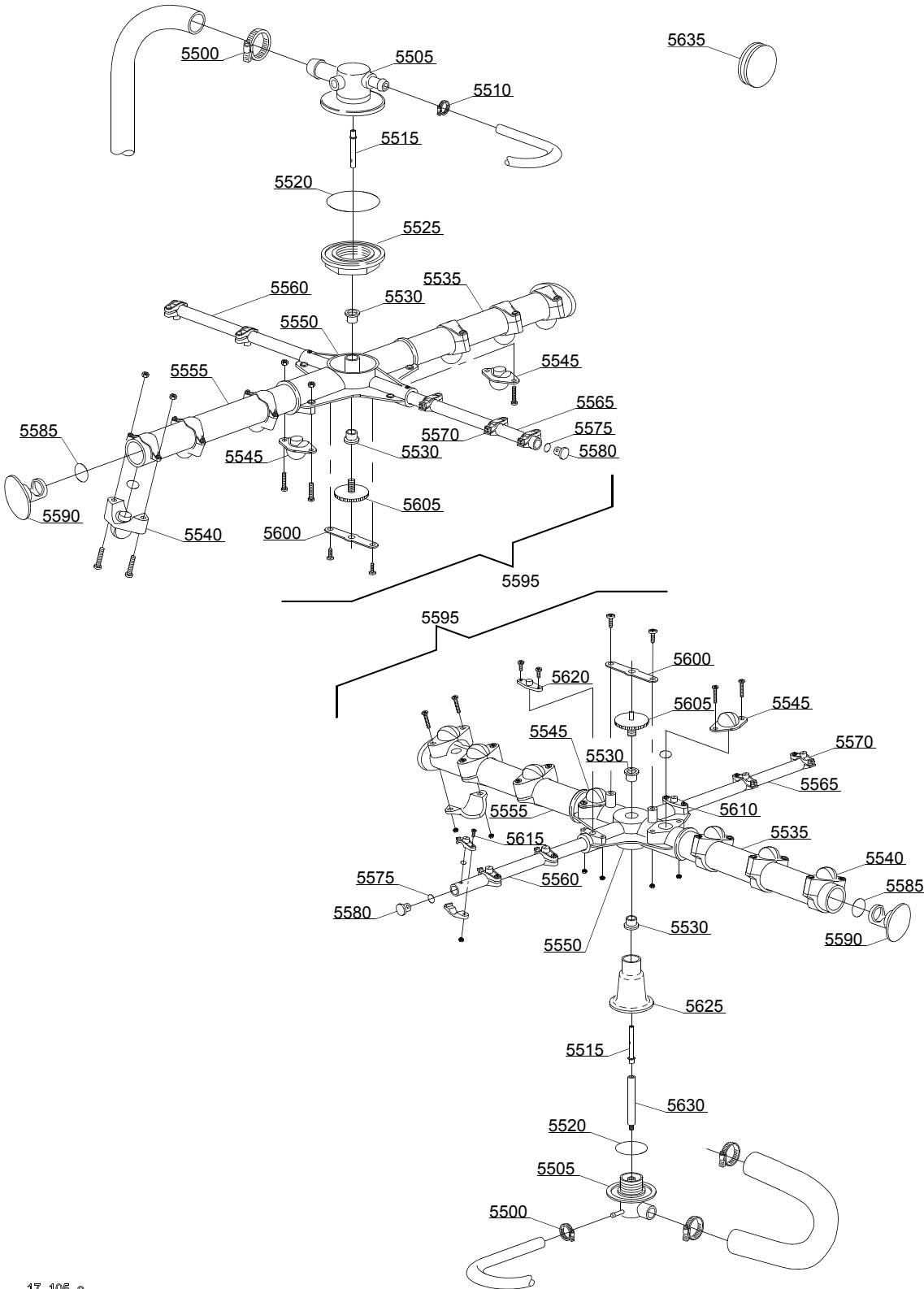

17_105_e

Spare parts

ID	P-code	SN from	SN to	Mod.	Acces.	Volt	Description
Module:Turret group with rotating arms							
5500	11806		-	em,uw			25/40 clamp (minimum 2 pieces)
5505	500612		-	em,uw			Top/lower turret
5510	11807		-	em,uw			12/22 clamp (minimum 3 pieces)
5515	15300		-	em,uw			Ø10x51 lower/top rinse axle
5520	13015		-	em,uw			6225 OR 160 NBR O-ring (minimum 5 pieces)
5525	500623	4017774	-	em,uw			Ring nut for fixing turret
5530	13319		-	em,uw			Sliding washer (minimum 4 pieces)
5535	15571		-	em,uw			Ø28 right wash pipe
5540	10261		-	em,uw			Ø28 raised nozzle (minimum 2 pieces)
5545	10268		-	em,uw			Ø28 opened plane nozzle (minimum 2 pieces)
5550	10259		-	em,uw			4 ways big rotor
5555	15572		-	em,uw			Ø28 left wash pipe
5560	15575		-	em,uw			Right rinse pipe
5565	15576		-	em,uw			Left rinse pipe
5570	10262		-	em,uw			Ø10 complet rinse nozzle (minimum 2 pieces)
5575	13016		-	em,uw			2018 OR 103 NBR O-ring (minimum 10 pieces)
5580	12532		-	em,uw			Ø10 plastic plug (minimum 3 pieces)
5585	13018		-	em,uw			OR 2087 NBR O-ring (minimum 10 pieces)
5590	10257		-	em,uw			Ø28 plastic plug (minimum 3 pieces)
5595	15958		-	em,uw			Ø28 wash/rinse group
5600	10260		-	em,uw			Blocking ring nut rotor plaque (minimum 10 pieces)
5605	11101/I		-	em,uw			Stainless steel group fixing screw
5610	10267		-	em,uw			Ø10 closed plane nozzle (minimum 2 pieces)
5615	11004		-	em,uw			4x10 TCB Ø8 spax toothed screw
5620	10263		-	em,uw			Ø10 opened plane nozzle (minimum 2 pieces)
5625	560004		4010319	em,uw			Lower pipe coupling
5625	560024	4010320	-	em,uw			Lower pipe coupling
5625	550225		4023175	em,uw			Lower pipe coupling

em=ELECTROMECHANICAL SWITCHES, uw=LOWER AND UPPER WASHING

9U=9U

bt=BREAK TANK, bp=BOOSTER PUMP, dvgw=DVGW, cr=COLD RINSE, ws=WATER SOFTNER, dd=DETERGENT DISPENSER, dp=DRAIN PUMP

A=3/N/PE~380-400V 50-60Hz, D=3/PE~200-210V 50-60Hz, F=2/PE~220-240V 50-60Hz, G=3/N/PE~415V 50-60Hz, H=3/PE~220-230V 50-60Hz, K=3/PE~380-400V 50-60Hz, L=3/PE~415V 50-60Hz, M=3/PE~440V 60Hz, P=1/N/PE~220-230V 50-60Hz, R=2/PE~220-240V 50-60Hz, U=1/N/PE~240V 50-60Hz, V=3/PE~240V 50-60Hz, W=1/N/PE~100-110V 50-60Hz

Spare parts

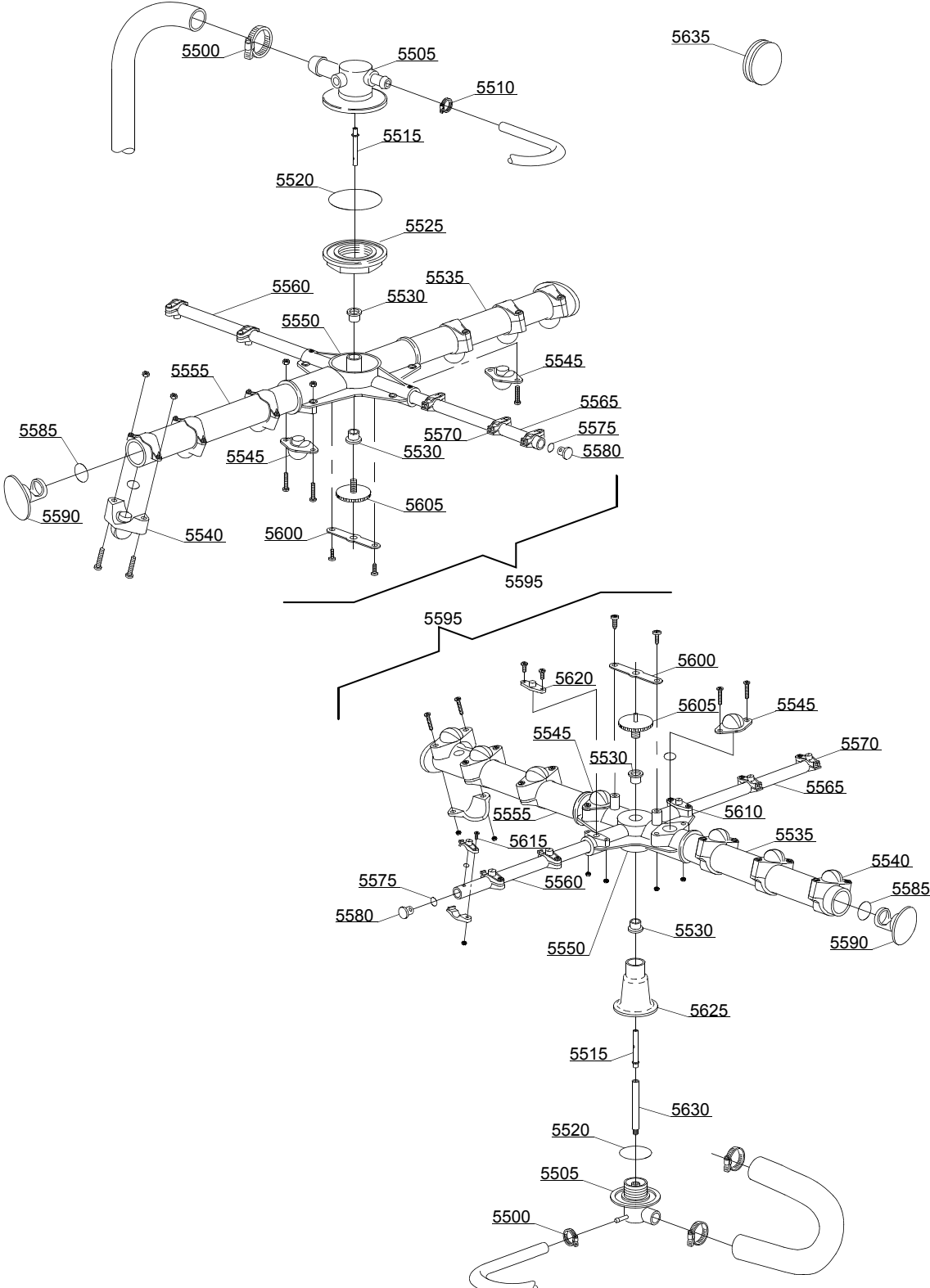

17_105_e

Spare parts

ID	P-code	SN from	SN to	Mod.	Acces.	Volt	Description
Module:Turret group with rotating arms							
5625	550225	4023176	-	em,uw			Lower pipe coupling
5630	550226		-	em,uw			Lower rinse axle
5635	13316/A		-	em,uw			DVGW hole O-ring

em=ELECTROMECHANICAL SWITCHES, uw=LOWER AND UPPER WASHING

9U=9U

bt=BREAK TANK, bp=BOOSTER PUMP, dvgw=DVGW, cr=COLD RINSE, ws=WATER SOFTNER, dd=DETERGENT DISPENSER, dp=DRAIN PUMP

A=3/N/PE~380-400V 50-60Hz, D=3/PE~200-210V 50-60Hz, F=2/PE~220-240V 50-60Hz, G=3/N/PE~415V 50-60Hz, H=3/PE~220-230V 50-60Hz, K=3/PE~380-400V 50-60Hz, L=3/PE~415V 50-60Hz, M=3/PE~440V 60Hz, P=1/N/PE~220-230V 50-60Hz, R=2/PE~220-240V 50-60Hz, U=1/N/PE~240V 50-60Hz, V=3/PE~240V 50-60Hz, W=1/N/PE~100-110V 50-60Hz

Spare parts

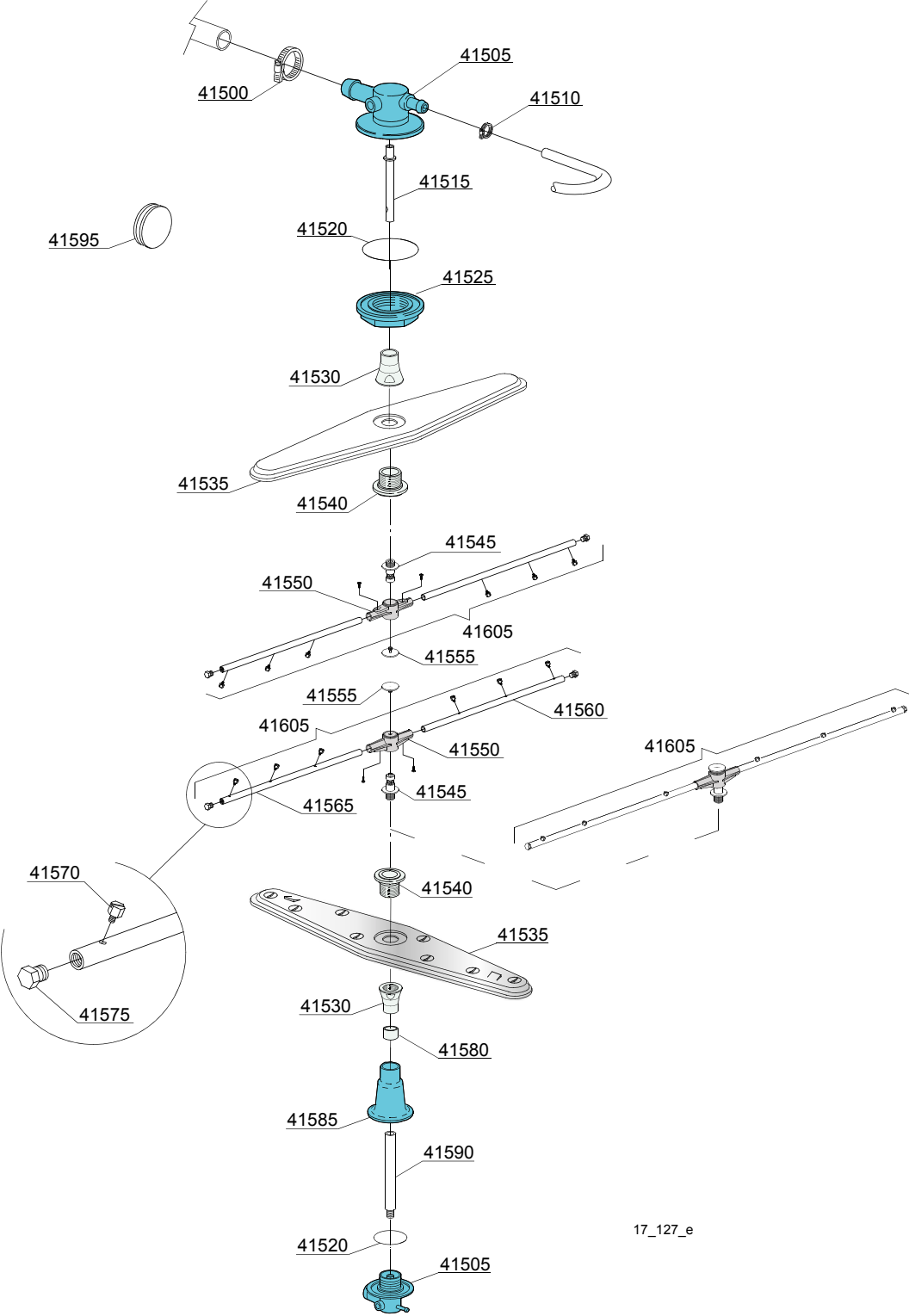

17_127_e

Spare parts

ID	P-code	SN from	SN to	Mod.	Acces.	Volt	Description
Module:Turret group with rotating arms							
41500	11806		-	uw			25/40 clamp (minimum 2 pieces)
41505	500612		-	uw			Top/lower turret
41510	11807		-	uw			12/22 clamp (minimum 3 pieces)
41515	75315		-	uw			Rinse axle extension
41515	500703		-	uw			Upper rinse axle extension
41520	13015		-	uw			6225 OR 160 NBR O-ring (minimum 5 pieces)
41525	500623		-	uw			Ring nut for fixing turret
41530	500702		-	uw			Nut for wash arm bearing 05 (inox rinse arm)
41535	500700		-	uw			Stainless steel wash rotor
41540	500701		-	uw			Hub for rotor (inox rinse arm)
41545	10651		-	uw			Rinse axle
41550	10650		-	uw			Rinse arm
41555	10652		-	uw			Rinse arm screw
41560	10657		-	uw			Right rinse arm - stainless steel nozzle
41565	10658		-	uw			Left rinse arm - stainless steel nozzle
41570	560018		-	uw			Stainless steel rinse nozzle
41575	560017		-	uw			Rinse arm plug
41580	550220		-	uw			Hub rotor/pipe coupling spacer
41585	550225		-	uw			Lower pipe coupling
41590	500704		-	uw			Rinse lower distributor connection axle
41595	13316/A		-	uw			DVGW hole O-ring
41605	75918		-	uw			Top/lower rinse arm complete

em=ELECTROMECHANICAL SWITCHES, uw=LOWER AND UPPER WASHING

9U=9U

bt=BREAK TANK, bp=BOOSTER PUMP, dvgw=DVGW, cr=COLD RINSE, ws=WATER SOFTNER, dd=DETERGENT DISPENSER, dp=DRAIN PUMP

A=3/N/PE~380-400V 50-60Hz, D=3/PE~200-210V 50-60Hz, F=2/PE~220-240V 50-60Hz, G=3/N/PE~415V 50-60Hz, H=3/PE~220-230V 50-60Hz, K=3/PE~380-400V 50-60Hz, L=3/PE~415V 50-60Hz, M=3/PE~440V 60Hz, P=1/N/PE~220-230V 50-60Hz, R=2/PE~220-240V 50-60Hz, U=1/N/PE~240V 50-60Hz, V=3/PE~240V 50-60Hz, W=1/N/PE~100-110V 50-60Hz

Spare parts

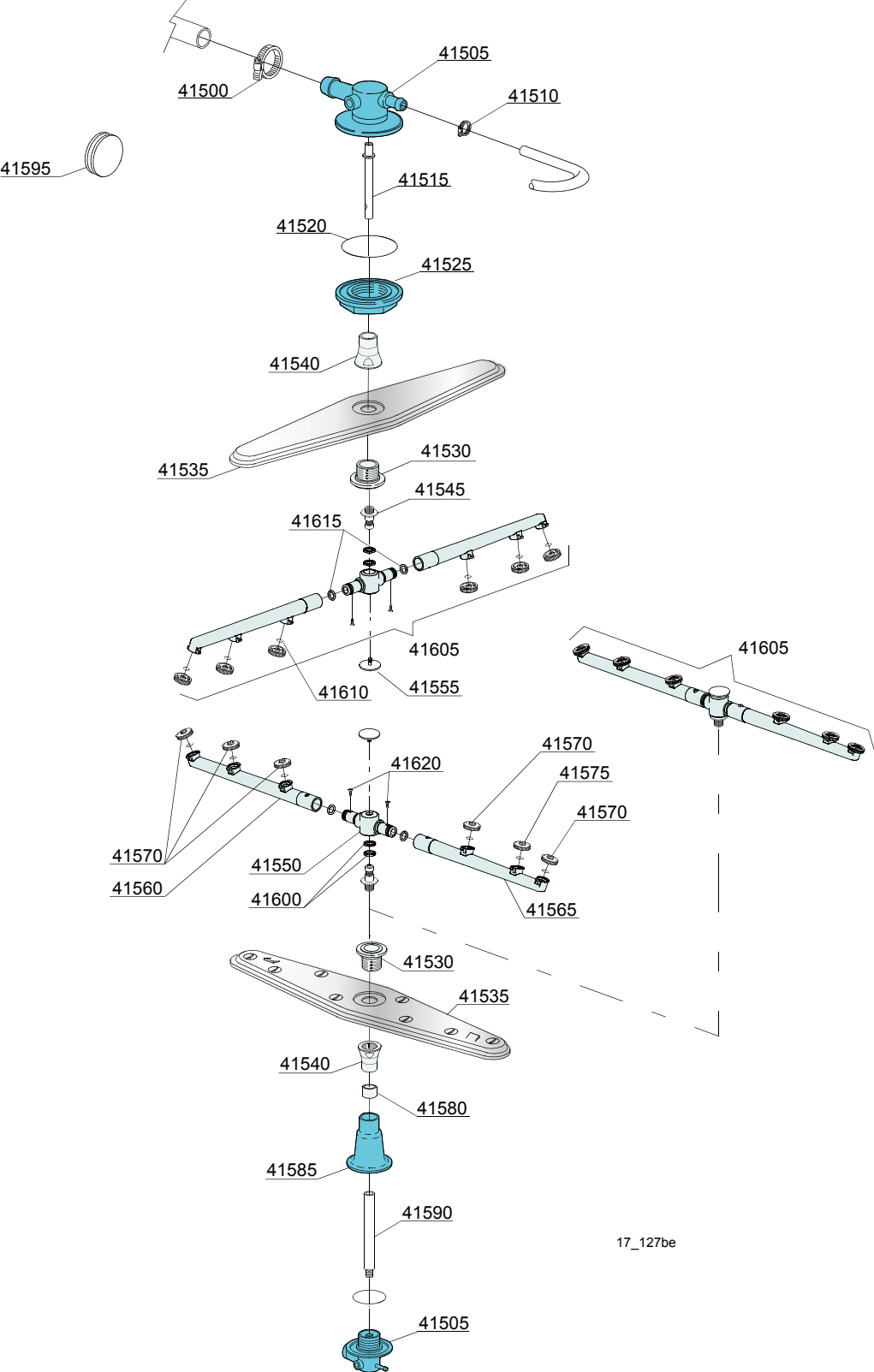

Spare parts

ID	P-code	SN from	SN to	Mod.	Acces.	Volt	Description
Module:Turret group with rotating arms							
41500	11806		-	uw			25/40 clamp (minimum 2 pieces)
41505	500612		-	uw			Top/lower turret
41510	11807		-	uw			12/22 clamp (minimum 3 pieces)
41515	500703		-	uw			Upper rinse axle extension
41520	13015		-	uw			6225 OR 160 NBR O-ring (minimum 5 pieces)
41525	500623		-	uw			Ring nut for fixing turret
41530	500702		-	uw			Nut for wash arm bearing 05 (inox rinse arm)
41535	500700		-	uw			Stainless steel wash rotor
41540	500701		-	uw			Hub for rotor (inox rinse arm)
41545	10651		-	uw			Rinse axle
41550	75920/A		-	uw			Rinse arm
41555	10652		-	uw			Rinse arm screw
41560	75920/D		-	uw			Right rinse arm
41565	75920/S		-	uw			Left rinse arm
41570	10371		-	uw			Open rinse nozzle
41575	10372		-	uw			Closed rinse nozzle
41580	550220		-	uw			Hub rotor/pipe coupling spacer
41585	550225		-	uw			Lower pipe coupling
41590	500704		-	uw			Rinse lower distributor connection axle
41595	13316/A		-	uw			DVGW hole O-ring
41600	75920/B		-	uw			O ring for hub (rinse arm)
41605	75920		-	uw			Top/lower rinse arm complete
41610	13002		-	uw			OR R6 NBR O-ring (minimum 10 pieces)
41615	13002		-	uw			OR R6 NBR O-ring (minimum 10 pieces)
41620	11004		-	uw			4x10 TCB Ø8 spax toothed screw

em=ELECTROMECHANICAL SWITCHES, uw=LOWER AND UPPER WASHING

9U=9U

bt=BREAK TANK, bp=BOOSTER PUMP, dvgw=DVGW, cr=COLD RINSE, ws=WATER SOFTNER, dd=DETERGENT DISPENSER, dp=DRAIN PUMP

A=3/N/PE~380-400V 50-60Hz, D=3/PE~200-210V 50-60Hz, F=2/PE~220-240V 50-60Hz, G=3/N/PE~415V 50-60Hz, H=3/PE~220-230V 50-60Hz, K=3/PE~380-400V 50-60Hz, L=3/PE~415V 50-60Hz, M=3/PE~440V 60Hz, P=1/N/PE~220-230V 50-60Hz, R=2/PE~220-240V 50-60Hz, U=1/N/PE~240V 50-60Hz, V=3/PE~240V 50-60Hz, W=1/N/PE~100-110V 50-60Hz

Spare parts

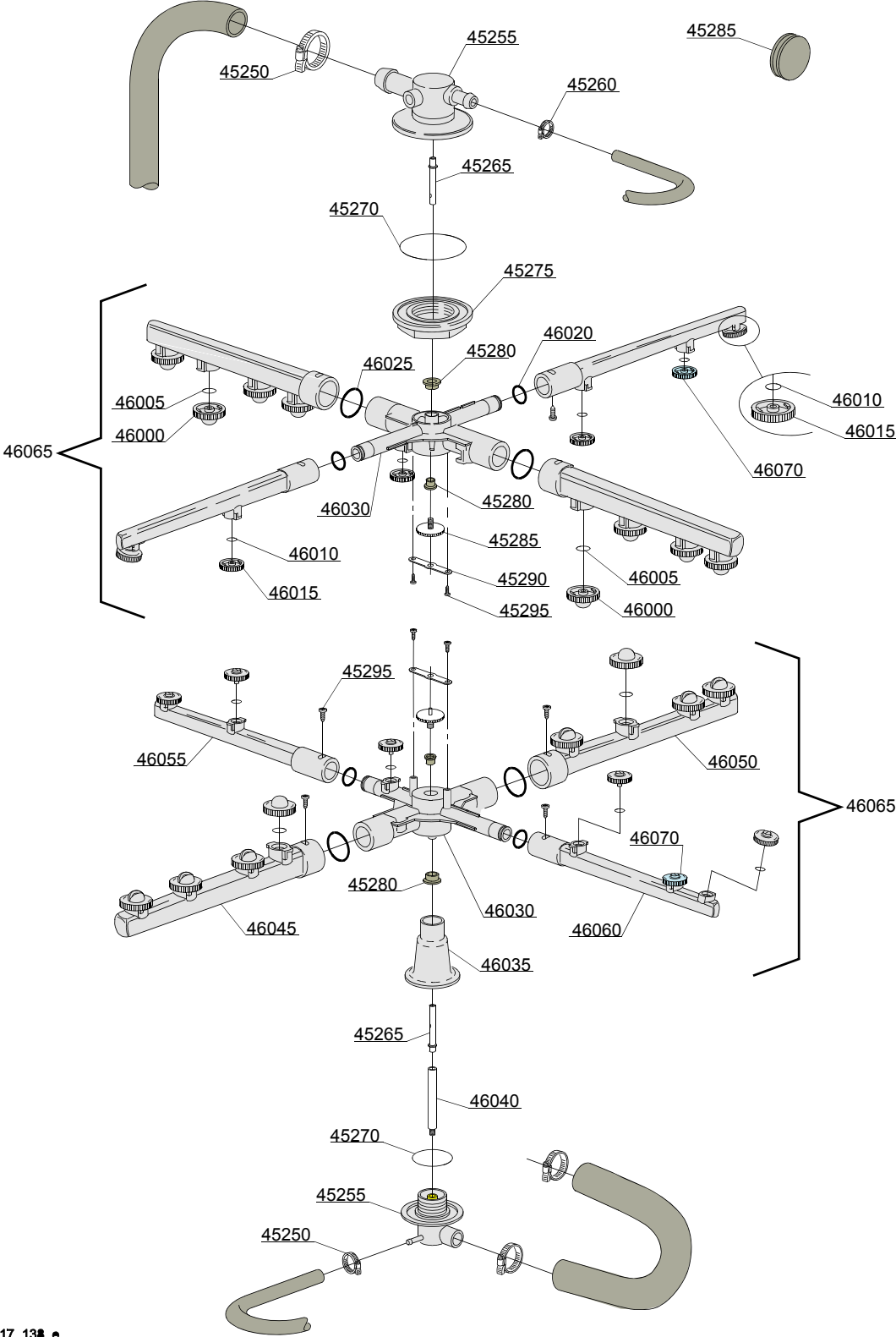

17_138_e

Spare parts

ID	P-code	SN from	SN to	Mod.	Acces.	Volt	Description
Module:Turret group with rotating arms							
45250	11806		-	em,uw			25/40 clamp (minimum 2 pieces)
45255	500612		-	em,uw			Top/lower turret
45260	11807		-	em,uw			12/22 clamp (minimum 3 pieces)
45265	15300		-	em,uw			Ø10x51 lower/top rinse axle
45270	13015		-	em,uw			6225 OR 160 NBR O-ring (minimum 5 pieces)
45275	500623		-	em,uw			Ring nut for fixing turret
45280	13319		-	em,uw			Sliding washer (minimum 4 pieces)
45285	11101/I		-	em,uw			Stainless steel group fixing screw
45290	10260		-	em,uw			Blocking ring nut rotor plaque (minimum 10 pieces)
45295	11004		-	em,uw			4x10 TCB Ø8 spax toothed screw
46000	10369		-	em,uw			Opened wash nozzle (minimum 2 pieces)
46005	13009		-	em,uw			OR 2050 NBR O-ring (minimum 10 pieces)
46010	13002		-	em,uw			OR R6 NBR O-ring (minimum 10 pieces)
46015	10371		-	em,uw			Opended rinse nozzle
46020	13002		-	em,uw			OR R6 NBR O-ring (minimum 10 pieces)
46025	13025		-	em,uw			OR 2081 O-ring (minimum 10 pieces)
46030	500755		-	em,uw			Under / upper turret wash rotor
46035	550225		-	em,uw			Lower pipe coupling
46040	550226		-	em,uw			Lower rinse axle
46045	500754		-	em,uw			Left wash pipe
46050	500753		-	em,uw			Right wash pipe
46055	500751		-	em,uw			Right rinse arm
46060	500752		-	em,uw			Left rinse arm
46065	500750		-	em,uw			Grey wash/rinse lower/upper distributor
46070	10372		-	em,uw			Closed rinse nozzle

em=ELECTROMECHANICAL SWITCHES, uw=LOWER AND UPPER WASHING

9U=9U

bt=BREAK TANK, bp=BOOSTER PUMP, dvgw=DVGW, cr=COLD RINSE, ws=WATER SOFTNER, dd=DETERGENT DISPENSER, dp=DRAIN PUMP

A=3/N/PE~380-400V 50-60Hz, D=3/PE~200-210V 50-60Hz, F=2/PE~220-240V 50-60Hz, G=3/N/PE~415V 50-60Hz, H=3/PE~220-230V 50-60Hz, K=3/PE~380-400V 50-60Hz, L=3/PE~415V 50-60Hz, M=3/PE~440V 60Hz, P=1/N/PE~220-230V 50-60Hz, R=2/PE~220-240V 50-60Hz, U=1/N/PE~240V 50-60Hz, V=3/PE~240V 50-60Hz, W=1/N/PE~100-110V 50-60Hz