

PNC	Model	Ref	Group	Level	Page	Notes
267202	AOS101ETA1	a	AOS	Touch	2...11	400V 3N 50Hz
267212	AOS101ETH1	b	AOS	Touch	2...11	400V 3N 50Hz P80
267222	AOS101ETN1	c	AOS	Touch	2...11	230V 3N
267232	AOS101ETC1	d	AOS	Touch	2...11	200V 3 60Hz Japan
267242	AOS101ETE1	e	AOS	Touch	2...11	440V 3 Marine
267252	AOS101ETF1	f	AOS	Touch	2...11	400V 3 Marine
267282	AOS101ETM1	h	AOS	Touch	2...11	208V 3 USA
267292	AOS101ETB1	i	AOS	Touch	2...11	240V 3 USA
267322	AOS101ETV1	il	AOS	Touch	2...11	480V 3 USA
267302	AOS101ETK1	l	AOS	Touch	2...11	400V 3N UK
268202	AOS101EBA2	n	AOS	Level B	2...11	400V 3N
268212	AOS101EBH2	o	AOS	Level B	2...11	400V 3N 50Hz P80
268222	AOS101EBN2	p	AOS	Level B	2...11	230V 3N
268232	AOS101EBC2	q	AOS	Level B	2...11	200V 3 60Hz Japan
268242	AOS101EBE2	r	AOS	Level B	2...11	440V 3 Marine
268252	AOS101EBF2	s	AOS	Level B	2...11	400V 3 Marine
268302	AOS101EBH2	t	AOS	Level B	2...11	400V 3N UK
269202	AOS101ECA2	u	AOS	Level C	2...11	400V 3N 50Hz
269212	AOS101ECH2	v	AOS	Level C	2...11	400V 3N 50Hz P80
269222	AOS101ECN2	z	AOS	Level C	2...11	230V 3N
237202	FCZ101ETA	A	FCZ	Touch	2...11	400V 3N 50Hz
237212	FCZ101ETH	B	FCZ	Touch	2...11	400V 3N 50Hz P80
237222	FCZ101ETN	C	FCZ	Touch	2...11	230V 3N
238202	FCZ101EBA2	D	FCZ	Level B	2...11	400V 3N 50Hz
238212	FCZ101EBH2	E	FCZ	Level B	2...11	400V 3N 50Hz P80
238222	FCZ101EBN2	F	FCZ	Level B	2...11	230V 3N
238232	FCZ101EBC2	G	FCZ	Level B	2...11	200V 3 60Hz Japan
239202	FCZ101ECA2	H	FCZ	Level C	2...11	400V 3N 50Hz
239212	FCZ101ECH2	I	FCZ	Level C	2...11	400V 3N 50Hz P80
239222	FCZ101ECA2	L	FCZ	Level C	2...11	230V 3N
269302	AOS101ECK2	M	AOS	Level C	2...11	400V 3N UK
269332	AOS101ECY2	N	AOS	Level C	2...11	400V 30 Bakery
267072	AOS101EAQ1	O	AOS	Level A	2...11	Nando's
269282	AOS101ECM1	P	AOS	Level C	2...11	208V 3 USA
266202	AOS101EKA1	Q	AOS	Level K	2...11	400V 3N 50Hz
266222	AOS101EKN1	R	AOS	Level K	2...11	230V 3N
266282	AOS101EKM1	S	AOS	Level K	2...11	208V 3 USA
236202	FCZ101 EKA	T	FCZ	Level K	2...11	400V 3N 50Hz
236222	FCZ101EKN	U	FCZ	Level K	2...11	230V 3N
266352	AOS101EKR1	A1	AOS	Level K	2...11	400V 3N 50/60HZ AUS
267352	AOS101ETR1	B1	AOS	Touch	2...11	400V 3N 50/60HZ AUS
268352	AOS101EBR2	C1	AOS	Level B	2...11	400V 3N 50/60HZ AUS
269352	AOS101ECR2	D1	AOS	Level C	2...11	400V 3N 50/60HZ AUS
269322	AOS101ECV1	E1	AOS	Level C	2...11	480V 3 60HZ USA
266322	AOS101EKV1	F1	AOS	Level K	2...11	480V 3 60HZ USA

Pag	Index	Indice	Note
2	Oven cabinet and door.	Cella forno e porta	
3	Water system	Impianto idraulico	
4	Boiler	Boiler	
5	Electrical components	Componenti elettrici	
6	Accessories	Accessori	
7...10	Spare parts list	Lista ricambi	

Brand/Marchio: All
 Factory code: 9PDD

From sr. Nr/ Da Ser. Nr.: 014	Page: 1	Ed. 2014 03	Doc. Nr.: 875400V00
From status level / Da scatto: 07			

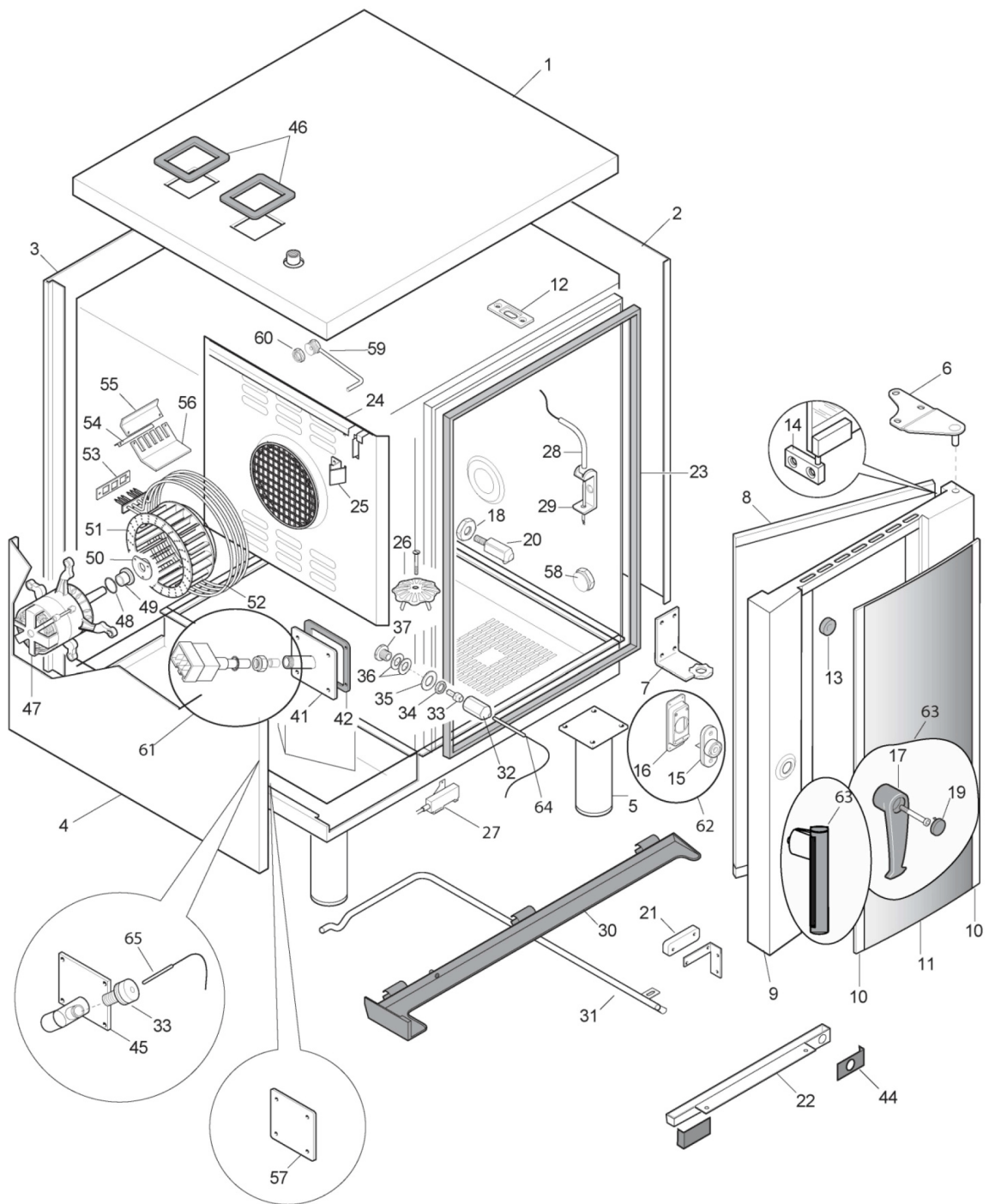

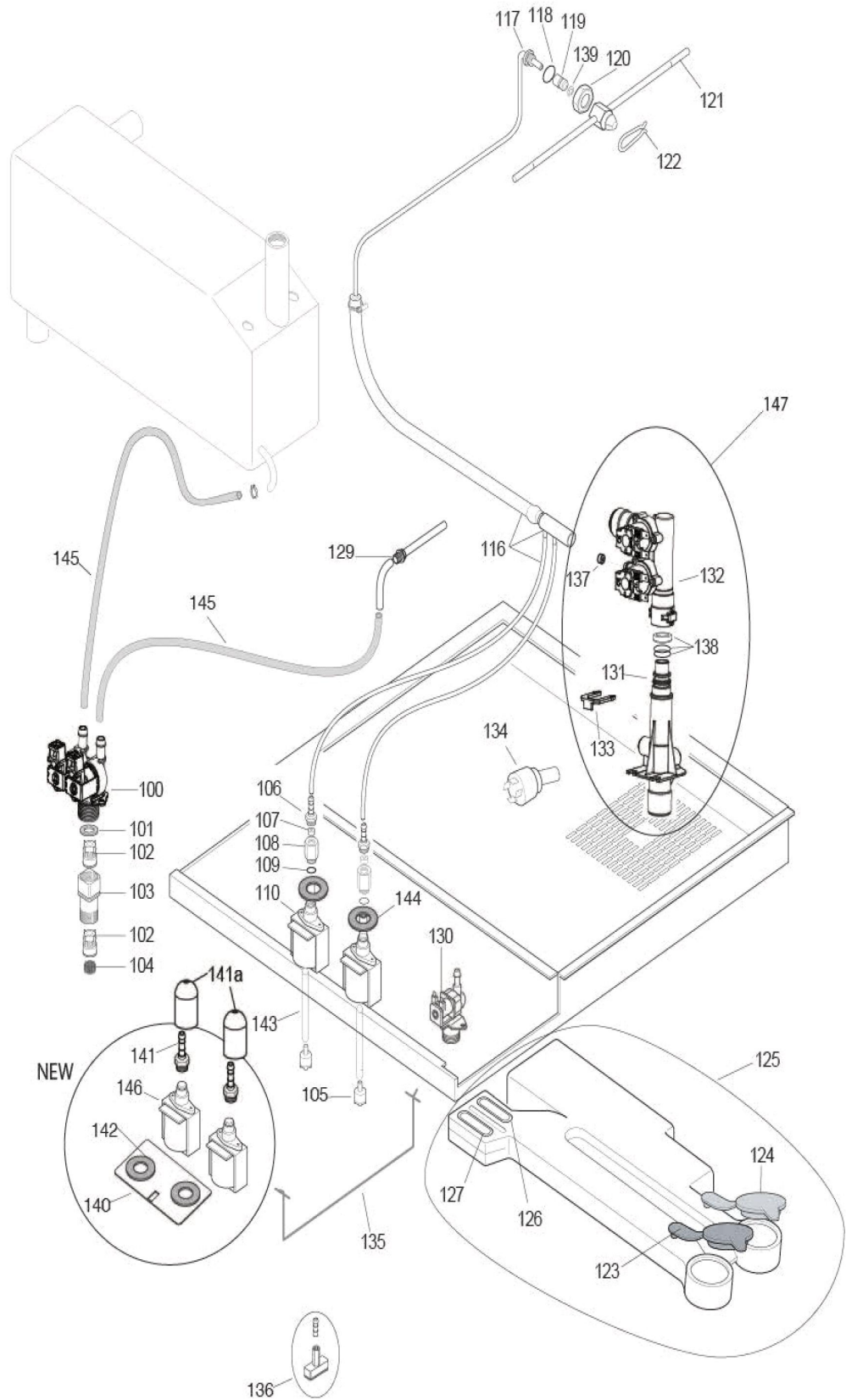

From sr. Nr/ Da Ser. Nr.: 014
 From status level / Da scatto: 07

Page: 3

Ed. 2014 03

Doc. Nr.: **875400V00**

Model	268202									
Table	875400V00		Page	3	Oven cabinet and door					
Pos.	Spare Part	Alias Code	Repl. by	S	Info	Kit	Techn. Bulletin	Description	Notes	
0001	0C6177	0590831300						LID; ONE 061-101E		
0002	0C6174	0530890900						RIGHT SIDE; ONE 101		
0003	0C6190	0530892700						BACK PANEL; ONE 101		
0003	0C6194	0530893100			D			BACK PANEL; ONE 101 MARINE	for Marine models	
0004	0C6196	0530893300						LEFT SIDE; ONE 101		
0005	0C4233	0831842202		S				FOOT; DIA.44,5; INOX	Up to 2007/52 from 2012/19	
0005	0C4823	0806872300						ADJUSTABLE FOOT; 2"INOX MARIN; 135-210MM	For Marine Version	
0005	0C4892	0831850900		S				FOOT; 2"	From 2008/01 up to 2012/18	
0006	0C4234	0806847803						PLATE; ASSY,UPPER AOSQ		
0007	0C4235	0806861600	0C9574					PLATE; ASSY.LOWER 6-10 AOSQ		
0008	0C4470	0873869902		S				DOOR GLASS; ASSY; LW10 AOSQ		
0009	0C6601	0879400504						DOOR ASSEMBLY; RIGHT		
0009	0C6606	0879400B04						DOOR ASSEMBLY	For Marine Touch and Level B	
0010	0C4476	0806859302		S				PROFILE; EST.LW10 AOSQ		
0011	0C4943	0574818501						DOOR GLASS; EXT; ONE 101	For FCZ Version	
0011	0C6559	0574400300						DOOR GLASS; 894X421MM; EXTERNAL	For AOS Version	
0011	0C7972	0574400P00						GLASS	For Nando's Version	
0012	0C4088	0543839700		S				GASKET		
0013	006976	0543828001		S				SHOCK ABSORBER		
0015	0C4089	0835871801	0C4477					LOCKING MECHANISM		
0016	0C4237	0510824200		S				SUPPORT; LW06-10 AOSQ		
0017	0C4090	0548871500		S				HANDLE; LW06-10 AOSQ		
0018	0C4238	0516896400	0CA756					NUT; FOR CATCH AOSQ		
0019	0C4091	0546822600		S				PLUG; LW06-10 AOSQ		
0020	0C4092	0806859900		S				CATCH		
0021	049627	0699603700						MAGNET		
0022	0C4239	0528869501						BOWL; LW06-101 AOSQ		
0023	0C1477	0831846901		S	A			DOOR GASKET; 725X450MM		
0024	0C4619	0830892205						SUCTION WALL; AOSQ 101 ELT		
0025	0C3423	0518807301						SPRING; SUCTION WALL		
0026	0C1740	0518808600		S				FILTER		
0027	049621	0654600000				+		REED SWITCH		
0028	0C4240	0831831000	0CB214		A			CORE PROBE; AOSQ T.C.MULTIPOINT	For Level TOUCH	
0028	0C4241	0831830700	0CB213	S	A			CORE PROBE; SINGLE POINT AOSQ	For Level B, C,K	
0029	0C1505	0527865201						SUPPORT		
0030	0C4242	0856814000		S				DRIP TRAY; 1/1 AOSQ		

Model	268202									
Table	875400V00		Page	3	Oven cabinet and door					
Pos.	Spare Part	Alias Code	Repl. by	S	Info	Kit	Techn. Bulletin	Description	Notes	
0031	0C4243	0806858800						HOSE		
0032	006991	0516855300						NUT		
0033	0C4872	0543842600		S				PLUG; FOR SENSOR		
0034	020997	0214105101						LOCK NUT		
0035	002701	0516809301						INSULATOR		
0036	002624	0543816300				Kit		GASKET; SET 50 PCS		
0037	002623	0516809400						PIPE FITTING		
0038	0C8561	0518818000		S				SPIRAL SPRING		
0040	0CB207	0856822203						DRAIN MANIFOLD	For Level C	
0041	0C4244	0806857201						FLANGE; FOR LAMBDA SONDE	For Level TOUCH	
0042	0C4093	0543838300		S				GASKET		
0044	0C4094	0543841300		S				GASKET		
0045	0C6351	0806873000						TUBE; WITH FLANGE	For Level B, C,K	
0046	007005	0543828901		S				GASKET		
0047	006998	0611806001		S	A			MOTOR ;190W 230 V 50/60 HZ; 4/6 POLES	For Level TOUCH,B Not for 60Hz version	
0047	0C1474	0611807300						MOTOR; 190W 230V 50/60 HZ 4/6 P; USA	For 60Hz Version	
0047	0C5287	0611809000		S	A			MOTOR; 1F 4P 190W 200-240V	For Level C	
0047	0C6936	0611400100						MOTOR; 480V-190W	For 480V	
0048	002873	0543816700						O-RING; ØI=MM.28,17X3,53		
0049	002699	0516808902						BEARING; FOR MOTOR SHAFT		
0050	0C4138	0538815400		S				FLANGE		
0051	000000	0835400800								
0052	007064	0617823801	0C5364		A			HEATING ELEMENT; 5670W-400V	for 400V models up to 138...	
0052	007066	0617826900	0C7052					HEATING ELEMENT; 5666W 230V	For 230V Version	
0052	0C1396	0617829200						HEATING ELEMENT; 5,5 KW 208V USA	For 208V Version	
0052	0C1500	0617829800						HEATING ELEMENT; 5,5KW 240V; USA	For 240V Version	
0052	0C1936	0617827000	0C7059					HEATING ELEMENT; 5,67KW 440V	For 440V Version up to 115...	
0052	0C6026	0617838900	0C6985		D			HEATING ELEMENT; 200V-5660W; W/PIVOT	For 200V Version	
0052	0C6501	0617400801	0C5364		A	+		HEATING ELEMENT; 400V-5670W	for 400V models from 139...	
0052	0C6942	0617400400						HEATING ELEMENT; 480V-5500W	For 480V USA	
0052	0C7059	0617400Q00		S	A			HEATING ELEMENT; 440V-5670W	For 440V Version from 116...	
0052	0CA330	0617400401						HEATING ELEMENT; 480V 5500W; USA VERSION	For 480V marine	
0053	002689	0543816501						HEATING ELEMENT GASKET		
0054	006253	0503897402		S				ANGLE		
0055	006256	0503891801		S				BLADE; FOR FIXING HEATING ELEMENT		
0056	0C3830	0505404N00						SUPPORT		

Pos.	Spare Part	Alias Code	Repl. by	S	Info	Kit	Techn. Bulletin	Description	Notes
0057	0C4857	0527898900						PLAQUE	for Level C,K
0058	000000								
0059	0C4975	0856828400		S				WATER PIPE; ONE 101/201 LIV.C	for Level C,K
0060	0C6228	0516887101		S				PIPE FITTING	for Level C,K
0061	0C6465				A	Kit	PDD2011-10	LAMBDA PROBE; KIT	for level TOUCH
0062	0CA733	835402M00		S				DOOR CLOSING ASSY; 6-10	From 6091...
0062	0CA757			S		Kit		DOOR CLOSING ASSY; KIT	Up to 6081...
0063	0C6569	0830400500		S				DOOR HANDLE	for AOS Group
0063	0C6572	0830400600		S				HANDLE; ASSY	for FCZ Group
0064	0C6538	0830898902		S	A			TEMPERATURE PROBE; L=500MM	
0065	0C6539	0830899101		S	A			THERMOCOUPLE PROBE; L=1100MM; STRAIGHT	
0066	0C7016	0543400900		S				GASKET; ØE=74MM; ØI=17MM; H=12,5MM	
0067	002692	0543816601						CAP; DESCALING LOAD IN THE BOILER	
0068	0C4965	0543843201		S				BUFFER	
008a	000000								

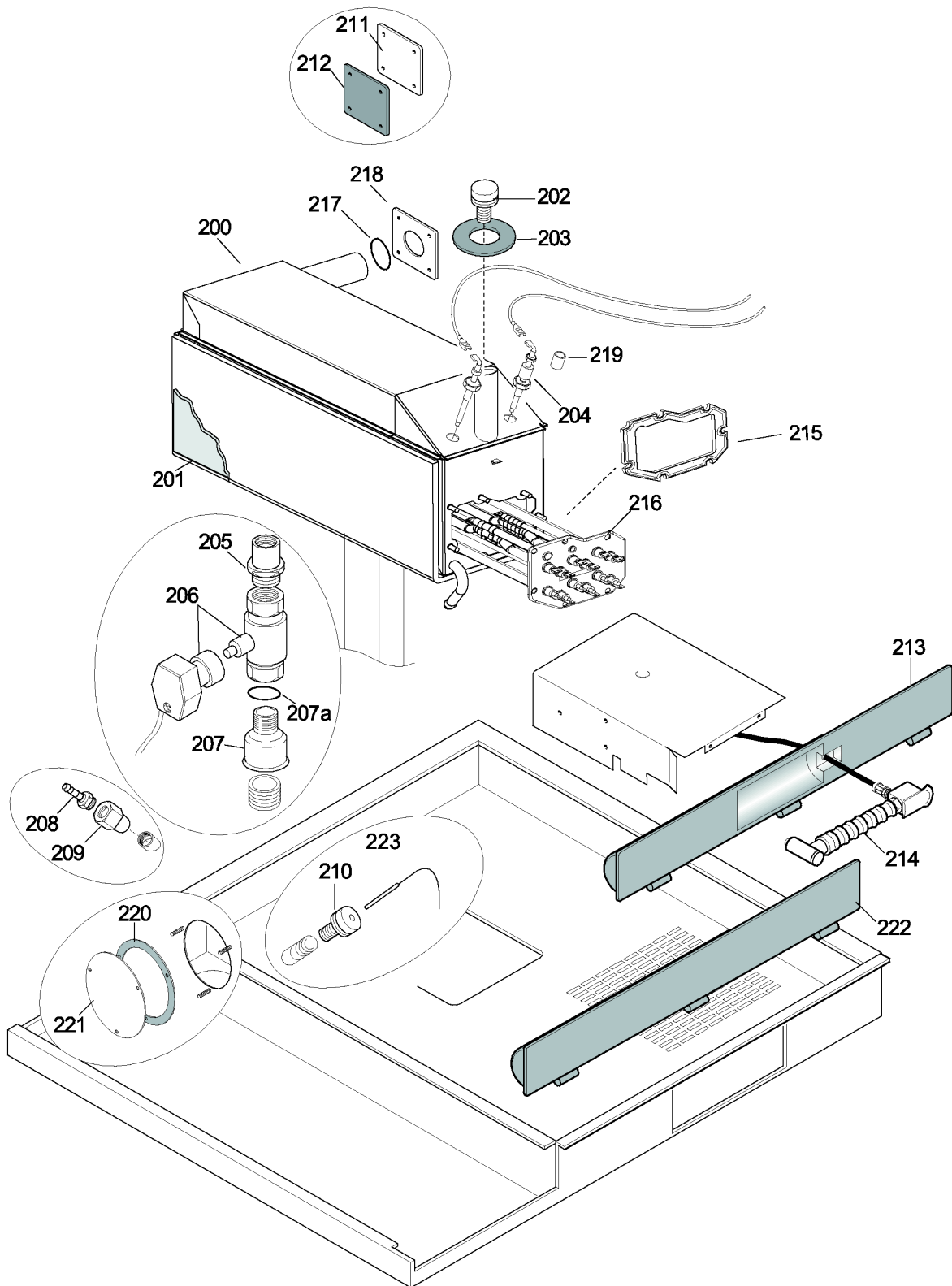

Model	268202									
Table	875400V00		Page	4	Water system					
Pos.	Spare Part	Alias Code	Repl. by	S	Info	Kit	Techn. Bulletin	Description	Notes	
0100	0C5516	0696808300		S	A			WATER SOLENOID VALVE;2 WAYS/180 2,5L/MIN	for Level A,B	
0101	0C4096	0543840600		S				FILTER GASKET	for Level A,B	
0102	0C2312	0549801800		S				NONRETURN VALVE	for Level A,B	
0103	0C2313	0516879400		S				PIPE FITTING	for Level A,B	
0105	0C1155	0831811400		S				FILTER		
0106	0C4198	0516896101		S				RUBBER HOLDER; G1/4" DIA 4 MM		
0107	0C1117	0544809000		S				NONRETURN VALVE		
0108	0C1116	0516871900		S				FITTING; RINSE AND DETERGENT PUMPS		
0109	0C1935	0543832300		S				O-RING; ØI=6,75X1,78 MM		
0110	0C2309			S				TUBE; BY METER		
0110	0C2341	0680801201	0CA120					PUMP	for 50 Hz	
0110	0C2342	0680801301		S	A			ELECTRIC PUMP; 120V 60HZ 32W	for 60 Hz	
0116	0C6202	0805400201		S				MANIFOLD; ASSY; C.S.ONE 061-101		
0117	0C6031	0806871100		S				DUCT; ASSY		
0118	0C4201	0543841400		S				GASKET; 17X22X1,5		
0119	0C4467	0516898301		S				BUSHING; FCS 6		
0120	0C4202	0516896000		S				LOCK NUT; INOX M16X1.5X6H		
0121	0C5503	0806873900	0C8317					WASH ARM; ASSY; L=422MM		
0122	007026	0518807100		S				SPRING		
0123	0C1151	0544808100		S				PLUG BLU		
0124	0C1152	0544808200		S				RED CAP		
0125	0C4426	0544808001		S				RESERVOIR; ASSY		
0126	0C1154	0544808900		S				WALL RED		
0127	0C1153	0544808400		S				WALL BLU		
0129	007012	0H22982600		S				PIPE	for Level A, B	
0129	0C4977	0856828600		S				WATER PIPE; ONE 061-101-201 LIV. C	for Level C,K	
0130	0C5515	0696808200		S	A			WATER SOLENOID VALVE; 1 VIA/180°	for Level C,K	
0131	0C6370	0831857200		S				MANIFOLD; ASSY		
0132	0C6373	0696400100			D		PDD2012-17	WATER DISTRIBUTOR; 1U-230V 1U-110V 50/60	for 60 Hz Version	
0132	0C6374	0696808600			D		PDD2012-17	WATER DISTRIBUTOR; 2 OUTPUT; 230V 50/60H	for Level TOUCH, B not for 60Hz version	
0132	0C6406	0696400300			D		PDD2012-17	WATER DISTRIBUTOR; 1U.230V-50/60HZ	for Level C,K	
0133	0C6222	0546825100		S				SAFETY DEVICE		
0134	0C6217	0646817200		S	A			PRESSURE SWITCH; GP600		
0135	0C5426	0513805000		S				STIRRUP		
0136	0C6467			S		Kit		TANK SUPPORT; KIT		
0137	0C6375			S		Kit		FLOW REDUCER; KIT 4PCS		

Model 268202

Table 875400V00 Page 4 Water system

Pos.	Spare Part	Alias Code	Repl. by	S	Info	Kit	Techn. Bulletin	Description	Notes
0138	0C6377					Kit		O-RING WITH BUSH; KIT	
0139	0C6421	0219035015		S				SPRING RING	
0140	0C7924	0505401R00		S				FIXING PLAQUE	
0141	0C8348	0544400C01	0CA348					RUBBER HOLDER; DIA.5MM 1/8"	Up to 5151...
0141	0CA348	0544400C02		S				RUBBER HOLDER; Ø5-1/8' WITH O-RING	From 5161...
0142	0C7925	0543400R00		S				CABLE GROMMET; ØINT 24.6 ØEST 38	
0143	0C2309	0546814600		S				TUBE; BY METER	
0144	005382	0246530100		S				GROMMET; DIA.22	
0145	0C5829	0544819400	0C4832					TUBE; BLU; 10X17; BY METER	
0146	0C8347	0686400100	0CA120					PUMP; 230-240V 50-60HZ; UL	Up to 4441...
0146	0CA112	0686400201	0CA120					PUMP;230V/50HZ 240V/60HZ UL;CLEANING SY	From 4451...
0147	0C8683	0835400L00		S				WATER INLET GROUP; 220 240V UL	
0147	0C8684	0835400M00		S				WATER INLET GROUP; 220 240V UL	For level C,K
141a	0C9538	0546400J00						PROTECTING CAP; BLACK	

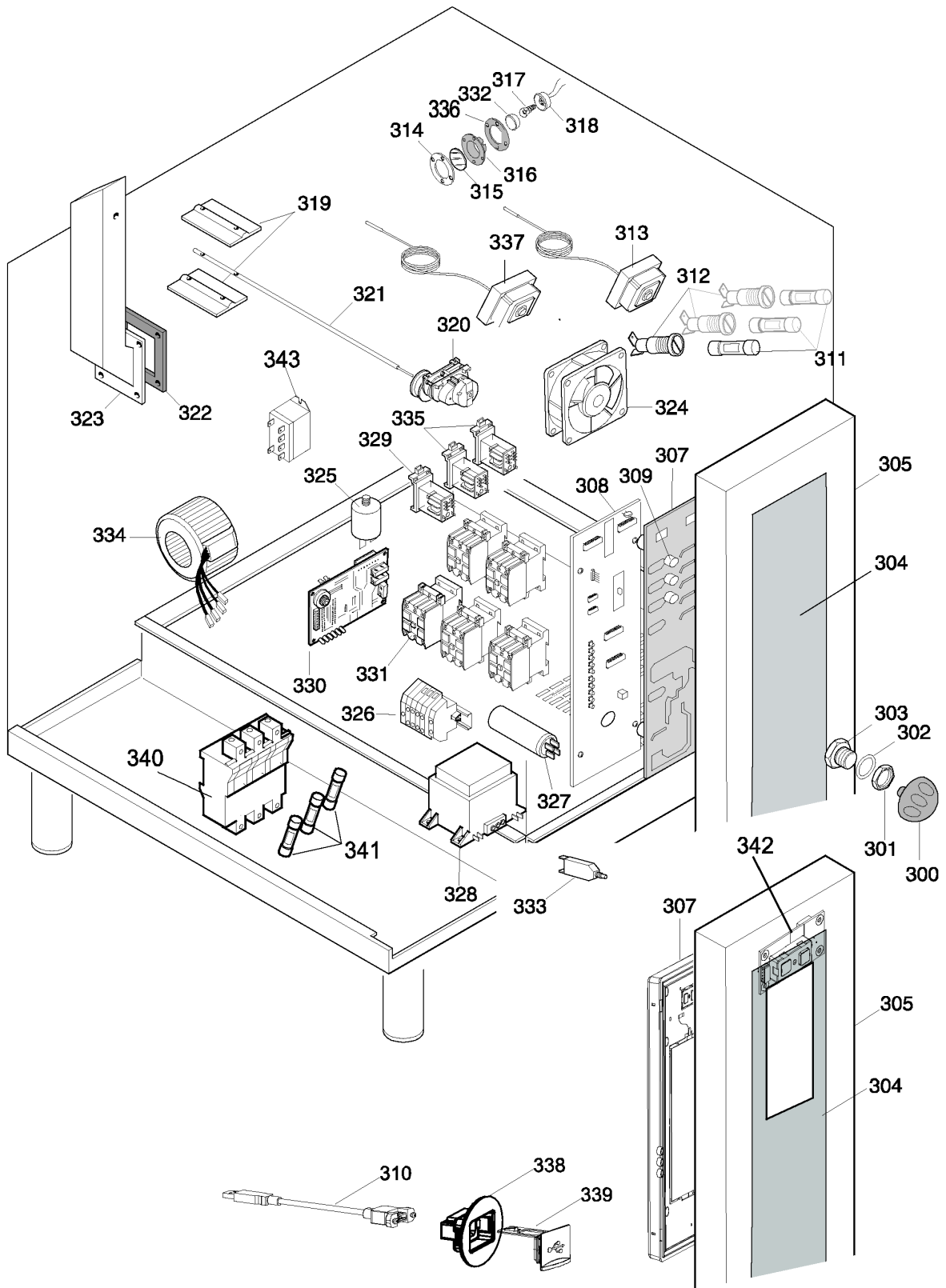

From sr. Nr/ Da Ser. Nr.: 014
 From status level / Da scatto: 07

Page: 5

Ed. 2014 03

Doc. Nr.: **875400V00**

Model	268202									
Table	875400V00		Page	5	Boiler					
Pos.	Spare Part	Alias Code	Repl. by	S	Info	Kit	Techn. Bulletin	Description	Notes	
0200	0C9662	0878401100		S	A			BOILER; KIT; ELT 6-101		
0201	0C5836	0569806900		S				BOILER INSULATION; ELT ONE 061-101		
0202	002692	0543816601						CAP; DESCALING LOAD IN THE BOILER		
0203	0C7016	0543400900		S				GASKET; ØE=74MM; ØI=17MM; H=12,5MM		
0204	007033	0830890500		S	A	+		LEVEL PROBE; BOILER		
0205	007117	0516809501		S				CONNECTION		
0206	0C0882	0696804201	0CB250	S	A			MOTOR-OPERATED VALVE; 3/4" 230V 50/60HZ		
0206	0C5518	0696808500	0CB251	S				BALL VALVE; 3/4" USA 240V 50/60HZ	For 60Hz Version	
0207	0C3847	0511820300		S				REDUCING SLEEVE; 1"1/4F-3/4"M		
0208	0C5564	0510828000		S				RUBBER HOLDER; 1/4"; FOR TUBE DIA.10MM		
0209	0C4099	0516879600		S				NOZZLE; 1/4"FD3.5-3/8"M		
0210	0C4872	0543842600		S				PLUG; FOR SENSOR		
0211	0C4856	0527898700						FLANGE	For Level C,K	
0212	0C4963	0543842800		S				GASKET; FOR BOILER	For Level C,K	
0213	0C4532	0546815103						FRONT PANEL; LOWER; 6-10 1/1 AOSQ		
0214	0C4248	0873881200		S				SHOWER UNIT; AOSQ	up to 5201...	
0214	0CA407	0875402G00		S				SHOWER UNIT; ONE 6-10 1/1; UK VERSION	for l and h1 from 5211...	
0215	0C5834	0543844800		S				GASKET; BOILER HEATING ELEMENT		
0216	0C5821	0617837100						HEATING ELEMENT; 208V-16500W	For 208V Version	
0216	0C5824	0617837700			A			HEATING ELEMENT; 240V-16500W	For 240V Version	
0216	0C5840	0617836400		S	A			HEATING ELEMENT; 400V-17000W	For 400V Version	
0216	0C5843	0617844800		S				HEATING ELEMENT; 230V-17000W	For 230V Version	
0216	0C5846	0617838300		S	A			HEATING ELEMENT; 440V-17000W	For 440V Version	
0216	0C6024	0617836900		S				HEATING ELEMENT; 200W-17000W	For 200V Version	
0216	0C6939	0617400100						BOILER HEATING ELEMENT; 480V-16500W	For 480V Version	
0217	002874	0543816800						O-RING; ØI=31,34X3,53 MM		
0218	0C4821	0527898600		S				FLANGE		
0219	055347	0515857001						SPACER; H=11,5MM		
0220	0C7033	0543400000		S				GASKET	for level TOUCH	
0221	0C3443	0J89061403						WASHER; FOR DOOR		
0222	0C8597	0546821401						FRONT PANEL	For Level B	
0223	0C6539	0830899101		S	A			THERMOCOUPLE PROBE; L=1100MM; STRAIGHT	for Level TOUCH e B	
0224	0C5283	0544820101	0C5006					HOSE; L=450 D.I=29/SP.5 -EPDM-		
207a	002874	0543816800						O-RING; ØI=31,34X3,53 MM		

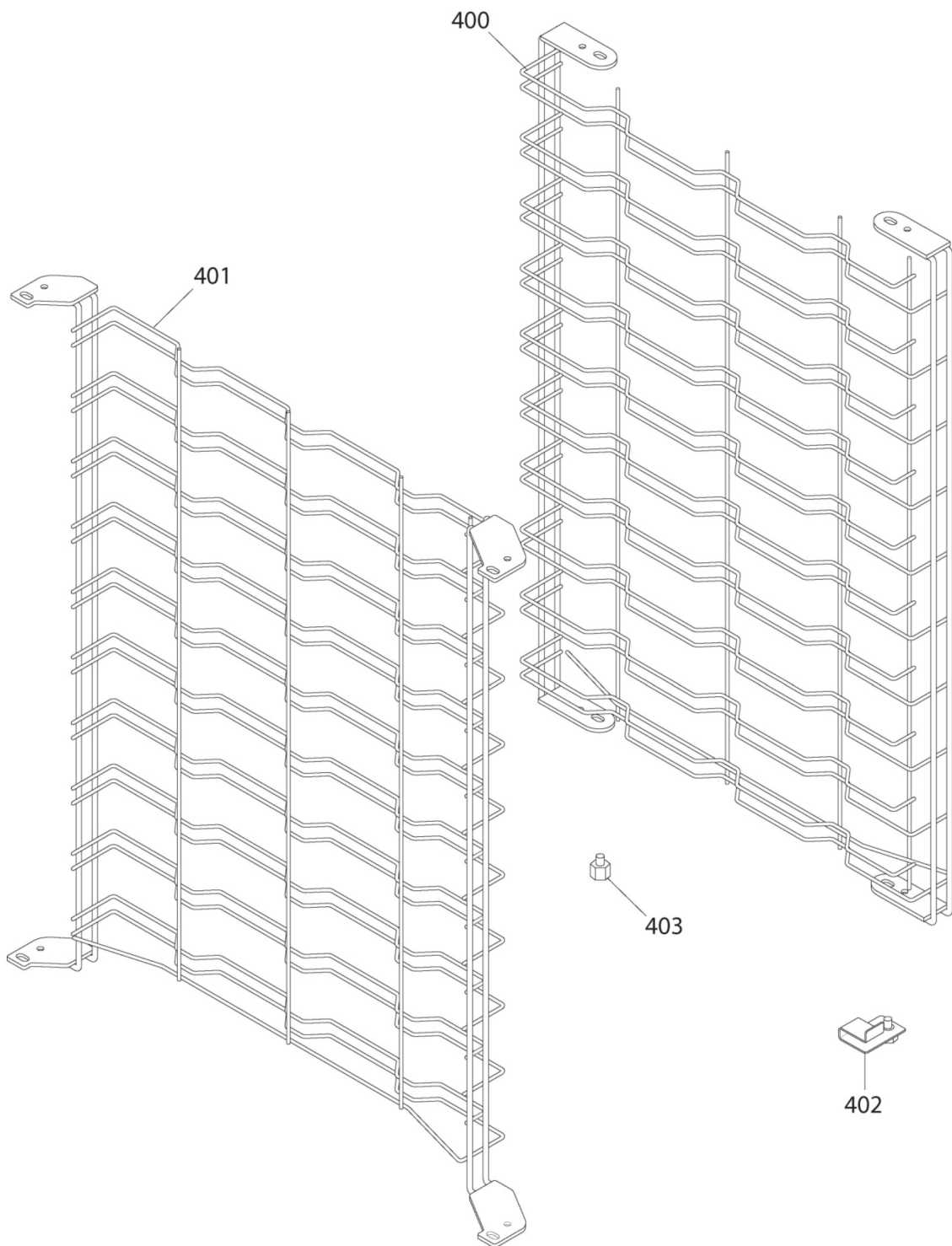

Model	268202								
Table	875400V00		Page	6	Electrical components				
Pos.	Spare Part	Alias Code	Repl. by	S	Info	Kit	Techn. Bulletin	Description	Notes
0300	0C5600	0806874001	0C4875					KNOB	For level B, C,K
0301	051263	0214114900						LOCK NUT	For level B, C,K
0302	002727	0508836400						WASHER	For level B, C,K
0303	002662	0516807301						BUSH	For level B, C,K
0304	0C4948	0675855002						ADHESIVE MEMBRANE; ONE; LIV.B	for Level B FCZ Group
0304	0C4949	0675855103						ADHESIVE MEMBRANE; ONE; LIV.C	for Level C FCZ Group
0304	0C6549	0548400500						ADHESIVE MEMBRANE	for TOUCH AOS Group
0304	0C6551	0548400B00						ADHESIVE MEMBRANE	for TOUCH FCZ Group
0304	0C6553	0548400F00						ADHESIVE MEMBRANE	for Level B AOS Group
0304	0C6556	0548400J00						ADHESIVE MEMBRANE	for Level C AOS Group
0304	0C7961	0675847601						ADHESIVE MEMBRANE	for Nando's Model
0304	0C8084	0548401900						ADHESIVE MEMBRANE; ONE 10 LIV.C	for Level C Bakery
0304	0C8706	0548401G00						ADHESIVE MEMBRANE; TOUCHSCREEN 10 "K"	For Level Touch "K" AOS Group
0305	0C4901	0873895902						CONTROL PANEL; ASSY; ONE 101 LIV.A	For Nando's Model
0305	0C4902	0873896002						CONTROL PANEL; ONE 101 LIV.B	for Level B FCZ Group
0305	0C4903	0873896102						CONTROL PANEL; ONE 101 LIV.C	for Level C FCZ Group
0305	0C6582	0870400501	0C7030					CONTROL PANEL; 101 TOUCH	for TOUCH AOS Group
0305	0C6583	0870400600						CONTROL PANEL; 101 LIV.B	for Level B AOS Group
0305	0C6592	0870400J00						CONTROL PANEL	for TOUCH FCZ group
0305	0C6593	0870400K00						CONTROL PANEL; 101 LIV.C	for Level C AOS Group
0305	0C8711	0875401U00						CONTROL PANEL; COMPLETE W/ MEMBRANE	For Level Touch "K" AOS Group
0307	0C0041	0675838802		S	A			USER INTERFACE; LIV B	for Level B
0307	0C0043	0675837904		S	A			USER INTERFACE BOARD; COPUI20-A; LEV.A	for Nando's model from to115..
0307	0C3915	0675847701						USER INTERFACE BOARD; USER INTERFACE NAN	for Nando's model up to 114...
0307	0C4891	0675854600			D	PDD2012-16		USER INTERFACE BOARD	for Level C
0307	0C6571	675400A00	0CA070					USER INTERFACE BOARD; COPUI40-T	for Level TOUCH,K up to 2441...
0307	0C7350	0675854602		S	A			USER INTERFACE BOARD	for level C (stard s/n 120...)
0307	0C8805	675400P01	0CA070					USER INTERFACE BOARD	for Level TOUCH,K from 2451... up to 4481...
0307	0CA070	675400P03		S				USER INTERFACE BOARD; COPUI40-T (REV5)	for Level TOUCH,K from4491...
0308	0C0042	0675837808		S	A			POWER BOARD; COP20-A; LIV A/ B/C LW	for Level B, C,Nando's from 115...
0308	0C3750	0546814001	0C3751					SPACER; 6.6	for Level B, C ,K
0308	0C3916	0675851401						PCB; COP20-A LW NANDOS	For Nando's up to 114...
0308	0C6564	0633847400		S				SHIELDED CABLE	for TOUCH level
0308	0C6570	0675400801		S	A			MOTHERBOARD; COP20-T SW1.60	for Level TOUCH,K
0310	0C6565	0638400P00						EXTENSION CABLE	for TOUCH level

Model	268202									
Table	875400V00		Page	6	Electrical components					
Pos.	Spare Part	Alias Code	Repl. by	S	Info	Kit	Techn. Bulletin	Description	Notes	
0310	0C6566	0638400Y00						USB EXTENSION; L=340MM	for TOUCH level	
0311	058871	0652800901						FUSE; 6,3A; 5X20; QUICK ACTING	For 400V; 230V	
0311	0C1480	0652803300		S				FUSE; 5*20 6,3A T; USA		
0311	0C1480	0652803300		S				FUSE; 5*20 6,3A T; USA	For 208V; 240V ; 480V	
0311	0C2230	0652805100		S				FUSE; 6,3*32 FAST 6,3A 500V OMEGA GF6322	For Marine Version	
0311	0C2236	0652805200						FUSE; 1.6A FAST 5X20 WEBER 0401601	For 200V	
0311	0C2301	0652803900		S				FUSE; OMEGA 800MA (COD. ST22180)	For 400V; 230V	
0311	0C3650	0652804900	0C3651					FUSE; 6,3X32 FAST 3,15A 500V	For Marine Version	
0311	0C4996	0652806100		S	A			FUSE; 3,15A 5X20; TIME-LAG	For E,F1	
0311	0C6034	0652803100						FUSE; TIME-LAG; 5X20 T1.6A	For 200V	
0311	0C6946	0652400000		S				FUSE; 500V-3,15A; 6,3X32MM	For 480V	
0312	0C2228	0652804800	0CB130					FUSE CARRIER; SCHURTER FEC 0031.1631+003	For Marine Version	
0312	0F0031	0652802100	0CB128					FUSE HOLDER; SET 2PCS	For 400V; 230V	
0313	006314	0646810802		S				SAFETY THERMOSTAT; 338 C	for USA models and I1	
0313	007042	0646812200		S	A			SAFETY THERMOSTAT; 357°C		
0314	002628	0508840801						FLANGE		
0315	002627	0574804900					+	LAMP GLASS		
0316	002626	0543817202					+	LAMP HOLDER GASKET		
0317	0C4396	0660808300	0C9877		A			HALOGEN LAMP; 12V-10W 300GR C.	Up to 4361...	
0317	0C9877	0660400100		S				HALOGEN LAMP; 12V 10W G4	From 4371...	
0318	007055	0660806401		S				LAMP HOLDER		
0319	007081	0508896801		S				JALOUSIE		
0320	0C5501	0680802300	0C0883					GEARMOTOR; 230V-50HZ		
0320	0C5502	0680802400	0C8695					GEARMOTOR; 24V-60HZ; USA		
0320	0C8687	0680400100	0C8692		A	+		GEARMOTOR; 230V 50HZ		
0320	0C8695	0680802B00		S				GEARMOTOR; 240V 60HZ; USA	pos. L1	
0321	0C5525	0856832702						STEM; 6-10 1/1 ELECTRIC		
0322	007053	0543828600		S				GASKET		
0323	0C5528	0831855200						AIR DUCT; ASSY; 10 1/1 ELETRIC		
0324	0CB143	0682400700		S				FAN; WITH CABLE L=250mm		
0325	049303	0694605400						RADIO INTERFERENCE FILTER; 250V 50/60HZ	not for Marine e USA	
0326	0C6028	0639813100			D			TERMINAL BOARD; TXM60	For 200V Version	
0326	0F0112	0639808600						TERMINAL BOARD		
0327	047541	0694604400						CAPACITOR; 12,5MF	for Level K, Touch, A e B - not for USA models	
0327	0C5526	0694806000		S				CAPACITOR; 8 MF	for Level C – not marine and USA models	
0328	007046	0624807100	0C9865					TRANSFORMER;100/200/230V 12/24V 50/60HZ	For Japan models	

Model		268202		Page		6		Electrical components	
Table		875400V00							
Pos.	Spare Part	Alias Code	Repl. by	S	Info	Kit	Techn. Bulletin	Description	Notes
0328	0C0949	0624807700						TRANSFORMER	for Marine models except for I1
0328	0C6895	0624400100	0C6400		A			TRANSFORMER; 70VA 230V 11.5/24V 30/40VA	Up to 3291 except for Japan, USA and Marine models
0328	0C9557	0624400900	0C6400					TRANSFORMER; 100VA 230/10-24V 50-50VA	From 3301 except for Japan, USA and Marine models
0329	058857	0648803001						RELAY	
0329	088267	0648722900		S				RELAY; COIL 200-240VAC	For 60Hz Version
0330	007047	0624807002		S	A			POWER SUPPLY BOARD; LAMBDA PROBE	
0331	006879	0648807400		S	A			CONTACTOR; 220-240V 50HZ/240-264V 60HZ	
0331	007080	0648807700		S	A			CONTACTOR; 220-240V 50HZ/240-264 60HZ	For 230V; 200V; 208V; 240V
0331	088477	0648807300		S	A			CONTACTOR; 220-240V 50HZ/240-264V 60HZ	For 400V Version
0331	088557	0648400000		S	A			CONTACTOR; 220-230V 50HZ/240V 60HZ	For 480V
0331	0L0355	0648613200		S	A	+		CONTACTOR; 220-240V 50HZ/240-264V 60HZ	For 480V
0332	0C4459	0509803900		S				LAMP CAP	
0333	0F0045	0648805200						SWITCH; 240V-1,5A	For Marine Version
0334	0C6945	0624400002		S	A			TRANSFORMER; 450VA 12/24/120/208/220/240	For USA models and I1 or USA mode
0335	056466	0648802601						RELAY	For 60Hz Version
0336	0C5451	0543843500		S				LAMP HOLDER GASKET	
0337	006433	0646810902		S	A			SAFETY THERMOSTAT; 150 C	except for USA and I1 USA (touch and B) and I1
0337	0C2983	0646814900		S	A			OVERTEMPERATURE LIMITER; 140GR 3P	for Level TOUCH e B
0338	0C6547	0546400200						BOWL; FOR USB	for TOUCH level
0339	0C6546	0541400A00						PLUG; PER USB	for TOUCH level
0342	0C8033	0675858601		S				BUTTON; 0/I; TOUCH	
0343	088267	0648722900		S				RELAY; COIL 200-240VAC	For TOUCH level
0344	0C4934	0831851002		S				AIR FILTER; 061-101 'ONE'	
0345	0C9991	0549400F00		S				CONTROL PANEL FILTER; L=315MM	

Model 268202

Table 875400V00 Page 7 Accessories

Pos.	Spare Part	Alias Code	Repl. by	S	Info	Kit	Techn. Bulletin	Description	Notes
0400	0C4862	0831849200		S				CHROME GRID; DX ONE 101	For P 60 Version
0400	0C5015	0831852400						CHROME GRID; DX ONE 061	For P 80 Version
0401	0C4861	0831848900		S				CHROME GRID; SX ONE 101	For P 60 Version
0401	0C5014	0831852300						CHROME GRID; SX ONE 061	For P 80 Version
0402	0C4961	0806872800		S				SUPPORT	
0403	0C0325	0830899001		S	A			TEMP.PROBE; THERMOCOUPLE; L=85CM; BOILER	for Level TOUCH e B
0403	0C1567	0527839102						SUPPORT; RH	For Marine Version
0403	0C1568	0527839202						SUPPORT; LH	For Marine Version
0403	0C3458	0853852705						PAN HOLDER STRUCTURE; ASSY LW10	For Marine Version
0403	0C5620	0511828100		S				BAKING PAN SUPPORT	
0403	0C6539	0830899101		S	A			THERMOCOUPLE PROBE; L=1100MM; STRAIGHT	for Level TOUCH e B
0403	0C7028	0830400N00		S	A			SENSOR	