

PNC	Model	Ref	Group	Level	Page	Notes
267202	AOS101ETA1	a	AOS	Touch	2...11	400V 3N 50Hz
267212	AOS101ETH1	b	AOS	Touch	2...11	400V 3N 50Hz P80
267222	AOS101ETN1	c	AOS	Touch	2...11	230V 3N
267232	AOS101ETC1	d	AOS	Touch	2...11	200V 3 60Hz Japan
267242	AOS101ETE1	e	AOS	Touch	2...11	440V 3 Marine
267252	AOS101ETF1	f	AOS	Touch	2...11	400V 3 Marine
267282	AOS101ETM1	h	AOS	Touch	2...11	208V 3 USA
267292	AOS101ETB1	i	AOS	Touch	2...11	240V 3 USA
267322	AOS101ETV1	il	AOS	Touch	2...11	480V 3 USA
267302	AOS101ETK1	l	AOS	Touch	2...11	400V 3N UK
268202	AOS101EBA2	n	AOS	Level B	2...11	400V 3N
268212	AOS101EBH2	o	AOS	Level B	2...11	400V 3N 50Hz P80
268222	AOS101EBN2	p	AOS	Level B	2...11	230V 3N
268232	AOS101EBC2	q	AOS	Level B	2...11	200V 3 60Hz Japan
268242	AOS101EBE2	r	AOS	Level B	2...11	440V 3 Marine
268252	AOS101EBF2	s	AOS	Level B	2...11	400V 3 Marine
268302	AOS101EBH2	t	AOS	Level B	2...11	400V 3N UK
269202	AOS101ECA2	u	AOS	Level C	2...11	400V 3N 50Hz
269212	AOS101ECH2	v	AOS	Level C	2...11	400V 3N 50Hz P80
269222	AOS101ECN2	z	AOS	Level C	2...11	230V 3N
237202	FCZ101ETA	A	FCZ	Touch	2...11	400V 3N 50Hz
237212	FCZ101ETH	B	FCZ	Touch	2...11	400V 3N 50Hz P80
237222	FCZ101ETN	C	FCZ	Touch	2...11	230V 3N
238202	FCZ101EBA2	D	FCZ	Level B	2...11	400V 3N 50Hz
238212	FCZ101EBH2	E	FCZ	Level B	2...11	400V 3N 50Hz P80
238222	FCZ101EBN2	F	FCZ	Level B	2...11	230V 3N
238232	FCZ101EBC2	G	FCZ	Level B	2...11	200V 3 60Hz Japan
239202	FCZ101ECA2	H	FCZ	Level C	2...11	400V 3N 50Hz
239212	FCZ101ECH2	I	FCZ	Level C	2...11	400V 3N 50Hz P80
239222	FCZ101ECA2	L	FCZ	Level C	2...11	230V 3N
269302	AOS101ECK2	M	AOS	Level C	2...11	400V 3N UK
269332	AOS101ECY2	N	AOS	Level C	2...11	400V 30 Bakery
267072	AOS101EAQ1	O	AOS	Level A	2...11	Nando's
269282	AOS101ECM1	P	AOS	Level C	2...11	208V 3 USA
266202	AOS101EKA1	Q	AOS	Level K	2...11	400V 3N 50Hz
266222	AOS101EKN1	R	AOS	Level K	2...11	230V 3N
266282	AOS101EKM1	S	AOS	Level K	2...11	208V 3 USA
236202	FCZ101 EKA	T	FCZ	Level K	2...11	400V 3N 50Hz
236222	FCZ101EKN	U	FCZ	Level K	2...11	230V 3N
266352	AOS101EKR1	A1	AOS	Level K	2...11	400V 3N 50/60HZ AUS
267352	AOS101ETR1	B1	AOS	Touch	2...11	400V 3N 50/60HZ AUS
268352	AOS101EBR2	C1	AOS	Level B	2...11	400V 3N 50/60HZ AUS
269352	AOS101ECR2	D1	AOS	Level C	2...11	400V 3N 50/60HZ AUS
269322	AOS101ECV1	E1	AOS	Level C	2...11	480V 3 60HZ USA
266322	AOS101EKV1	F1	AOS	Level K	2...11	480V 3 60HZ USA

Pag	Index	Indice	Note
2	Oven cabinet and door.	Cella forno e porta	
3	Water system	Impianto idraulico	
4	Boiler	Boiler	
5	Electrical components	Componenti elettrici	
6	Accessories	Accessori	
7...10	Spare parts list	Lista ricambi	

Brand/Marchio: All
 Factory code: 9PDD

From sr. Nr/ Da Ser. Nr.: 014	Page: 1	Ed. 2014 03	Doc. Nr.: 875400V00
From status level / Da scatto: 07			

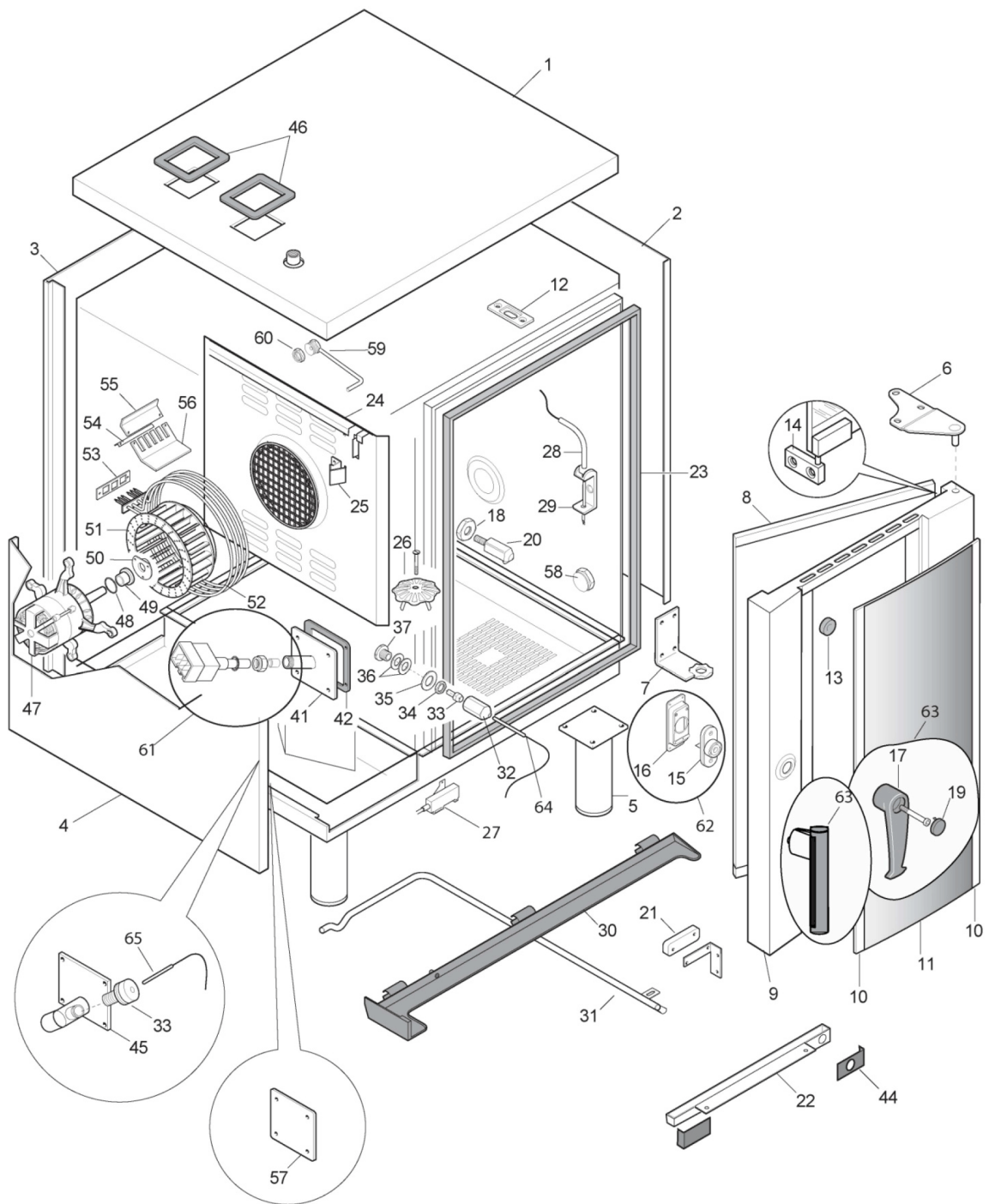

??????	267202									
??????	875400V00	???????? 2	Oven cabinet and door							
.		Alias		S			.			(Euro)
0001	OC6177	0590831300						LID; ONE 061-101E		143,10
0002	OC6174	0530890900						RIGHT SIDE; ONE 101		149,20
0003	OC6190	0530892700						BACK PANEL; ONE 101		106,60
0004	OC6196	0530893300						LEFT SIDE; ONE 101		139,10
0005	OC4823	0806872300		S	C			ADJUSTABLE FOOT; 2"INOX MARIN; 135-210MM	For Marine Version	39,99
0005	OC4892	0831850900		S				FOOT; 2"		11,46
0006	OC4234	0806847803		S				PLATE; ASSY,UPPER AOSQ		22,43
0007	OC4235	0806861600	OC9574					PLATE; ASSY.LOWER 6-10 AOSQ		
0008	OC4470	0873869902		S				DOOR GLASS; ASSY; LW101 AOSQ		90,94
0008	OC6576	0850400P00						DOOR CHASSIS; LW101		412,10
0009	OC6601	0879400500						DOOR ASSEMBLY		728,00
0010	OC4476	0806859302		S				PROFILE; EST.LW10 AOSQ		34,92
0011	OC4943	0574818501						DOOR GLASS; EXT; ONE 101	For FCZ Version	93,38
0011	OC6559	0574400300						DOOR GLASS; 894X421MM; EXTERNAL	For AOS Version	113,70
0011	OC7972	0574400P00						GLASS	For Nando's Version	181,70
0012	OC4088	0543839700		S				GASKET		8,13
0013	006976	0543828001		S				SHOCK ABSORBER		4,33
0014	007007	0806822000		S				HINGE		16,36
0015	OC4089	0835871801	OC4477					LOCKING MECHANISM		
0016	OC4237	0510824200		S				SUPPORT; LW06-10 AOSQ		18,98
0017	OC4090	0548871500		S				HANDLE; LW06-10 AOSQ		13,09
0018	OC4238	0516896400		S				NUT; FOR CATCH AOSQ		11,72
0019	OC4091	0546822600		S				PLUG; LW06-10 AOSQ		6,76
0020	OC4092	0806859900		S				CATCH		35,42
0021	049627	0699603700		S				MAGNET		9,82
0022	OC4239	0528869501		S				BOWL; LW06-101 AOSQ		59,68
0023	OC1477	0831846901		S				DOOR GASKET; 725X450MM		120,80
0024	OC4619	0830892205						SUCTION WALL; AOSQ 101 ELT		286,20
0025	OC3423	0518807301						SPRING; SUCTION WALL		19,63
0026	OC1740	0518808600		S				FILTER		13,26
0027	049621	0654600000		S	C	+		REED SWITCH		15,00
0028	OC4240	0831831000		S				CORE PROBE; AOSQ T.C.MULTIPOINT	For Level TOUCH	226,30
0028	OC4241	0831830700		S				CORE PROBE; SINGLE POINT AOSQ	For Level B, C,K	128,90
0029	OC1505	0527865201						SUPPORT		7,29
0030	OC4242	0856814000		S				DRIP TRAY; 1/1 AOSQ		19,07
0031	OC4243	0806858800		S				HOSE		33,19

??????	267202									
??????	875400V00	???????? 2	Oven cabinet and door							
.		Alias		S		.				(Euro)
0032	006991	0516855300						NUT		22,43
0033	0C4872	0543842600		S				PLUG; FOR SENSOR		7,29
0034	020997	0214105101		S				LOCK NUT		1,25
0035	002701	0516809301		S				INSULATOR		3,59
0036	002624	0543816300		S				GASKET; SET 50 PCS		24,16
0037	002623	0516809400		S				PIPE FITTING		10,04
0041	0C4244	0806857201		S				FLANGE; FOR LAMBDA SONDE	For Level TOUCH	40,09
0042	0C4093	0543838300		S				GASKET		11,09
0044	0C4094	0543841300						GASKET		11,61
0045	0C6351	0806873000						TUBE; WITH FLANGE	For Level B, C,K	44,05
0046	007005	0543828901		S				GASKET		6,02
0047	006998	0611806001		S				MOTOR ;190W 230 V 50/60 HZ; 4/6 POLES	For Level TOUCH,B Not for 60Hz version	228,40
0047	0C1474	0611807300						MOTOR; 190W 230V 50/60 HZ 4/6 P; USA	For 60Hz Version	227,40
0047	0C5287	0611809000		S				MOTOR; 1F 4P 190W 200-240V	For Level C	204,00
0047	0C6936	0611400100						MOTOR; 480V-190W	For 480V	253,80
0048	002873	0543816700		S				O-RING; ØI=MM.28,17X3,53		2,43
0049	002699	0516808902		S				BEARING; FOR MOTOR SHAFT		20,50
0050	0C4138	0538815400		S				FLANGE		5,81
0051	0C6463	0835400800		S				FAN BLADE		207,10
0052	007066	0617826900	0C7052					HEATING ELEMENT; 5666W 230V	For 230V Version	
0052	0C1396	0617829200						HEATING ELEMENT; 5,5 KW 208V USA	For 208V Version	169,50
0052	0C1500	0617829800						HEATING ELEMENT; 5,5KW 240V; USA	For 240V Version	172,60
0052	0C1936	0617827000	0C7059					HEATING ELEMENT; 5,67KW 440V	For 440V Version	
0052	0C6026	0617838900	0C6985		D			HEATING ELEMENT; 200V-5660W; W/PIVOT	For 200V Version	
0052	0C6501	0617400801	0C5364	S		+		HEATING ELEMENT; 400V-5670W	For 400V Version	
0052	0C6942	0617400400						HEATING ELEMENT; 480V-5500W	For 480V Version	134,00
0053	002689	0543816501		S				HEATING ELEMENT GASKET		26,09
0054	006253	0503897402		S				ANGLE		9,19
0055	006256	0503891801		S				BLADE; FOR FIXING HEATING ELEMENT		15,20
0056	0C3830	0527833700		S				SUPPORT		14,58
0057	0C4857	0527898900		S				PLAQUE	for Level C,K	6,33
0058	000000									
0059	0C4975	0856828400		S				WATER PIPE; ONE 101/201 LIV.C	for Level C,K	42,43
0060	0C6228	0516887101		S				PIPE FITTING	for Level C,K	18,88
0061	0C6465			S		Kit	PDD2011 -10	LAMBDA PROBE; KIT	for level TOUCH	173,60
0062	0C4477	0835872001		S			PDD2010 -11	DOOR CLOSING ASSY; AOSQ 6-10		158,30

??????	267202									
??????	875400V00	???????? 2	Oven cabinet and door							
.		Alias		S			.		(Euro)	
0063	0C6569	0830400500		S				DOOR HANDLE	for AOS Group	56,64
0063	0C6572	0830400600						HANDLE; ASSY	for FCZ Group	17,63
0064	0C6538	0830898902		S				TEMPERATURE PROBE; L=500MM		37,66
0065	0C6539	0830899101		S				THERMOCOUPLE PROBE; L=1100MM; STRAIGHT		40,19

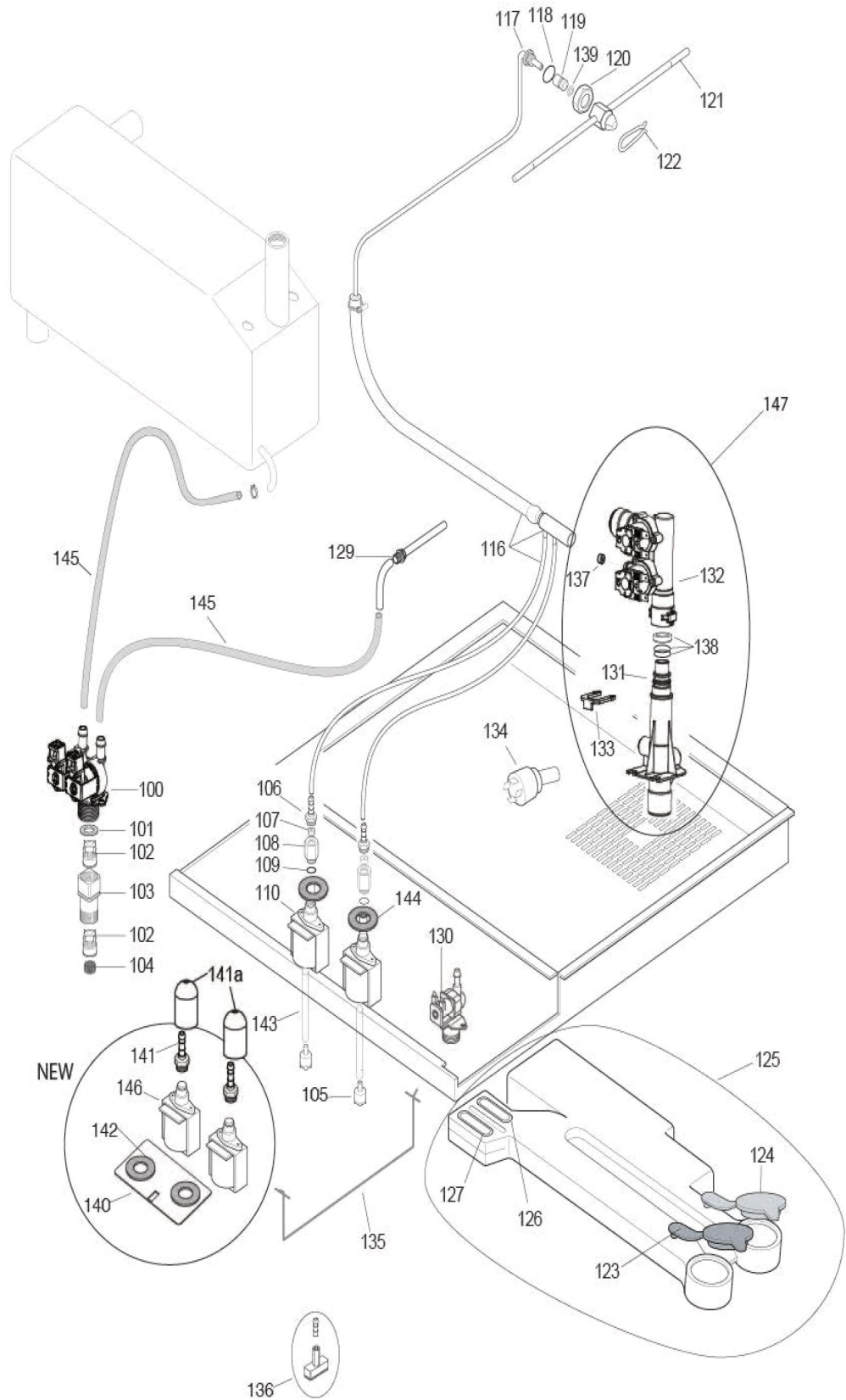

??????	267202									
??????	875400V00	???????? 3	Water system							
.		Alias		S			.			(Euro)
0100	OC5516	0696808300		S				WATER SOLENOID VALVE;2 WAYS/180 2,5L/MIN	for Level A,B	23,35
0101	OC4096	0543840600		S				FILTER GASKET	for Level A,B	1,27
0102	OC2312	0549801800		S				NONRETURN VALVE	for Level A,B	5,86
0103	OC2313	0516879400		S				PIPE FITTING	for Level A,B	29,54
0104	000000									
0105	OC1155	0831811400		S				FILTER		15,97
0106	OC4198	0516896101		S				RUBBER HOLDER; G1/4" DIA 4 MM		13,30
0107	OC1117	0544809000		S				NONRETURN VALVE		6,90
0108	OC1116	0516871900		S				FITTING; RINSE AND DETERGENT PUMPS		10,29
0109	OC1935	0543832300		S				O-RING; ØI=6,75X1,78 MM		1,02
0110	000000								For 50 Hz	
0110	OC2309			S				TUBE; BY METER		6,66
0110	OC2341	0680801201	OC6947					PUMP	for 50 Hz	
0110	OC2342	0680801301		S				ELECTRIC PUMP; 120V 60HZ 32W	for 60 Hz	60,39
0116	OC4246	0806864300		S		+		WASH MANIFOLD ASSY; AOSQ 061-101		33,70
0117	OC6031	0806871100		S				DUCT; ASSY		41,21
0118	OC4201	0543841400		S				GASKET; 17X22X1,5		2,53
0119	OC4467	0516898301		S				BUSHING; FCS 6		10,77
0120	OC4202	0516896000		S				LOCK NUT; INOX M16X1.5X6H		5,33
0121	OC5503	0806873900	OC8317					WASH ARM; ASSY; L=422MM		
0122	007026	0518807100		S				SPRING		14,25
0123	OC1151	0544808100		S				PLUG BLU		3,08
0124	OC1152	0544808200		S				RED CAP		2,76
0125	OC4426	0544808001		S				RESERVOIR; ASSY		52,07
0126	OC1154	0544808900		S				WALL RED		4,13
0127	OC1153	0544808400		S				WALL BLU		4,13
0129	007012	0H22982600		S				PIPE	for Level A, B	29,64
0129	OC4977	0856828600		S				WATER PIPE; ONE 061-101-201 LIV. C	for Level C,K	28,62
0130	OC5515	0696808200		S				WATER SOLENOID VALVE; 1 VIA/180°	for Level C,K	15,86
0131	OC6370	0831857200		S				MANIFOLD; ASSY		42,43
0132	OC6373	0696400100			D	PDD2012-17		WATER DISTRIBUTOR; 1U-230V 1U-110V 50/60	for 60 Hz Version	70,04
0132	OC6374	0696808600			D	PDD2012-17		WATER DISTRIBUTOR; 2 OUTPUP; 230V 50/60H	for Level TOUCH, B not for 60Hz version	100,30
0132	OC6406	0696400300			D	PDD2012-17		WATER DISTRIBUTOR; 1U.230V- 50/60HZ	for Level C,K	55,52
0133	OC6222	0546825100		S				SAFETY DEVICE		6,26
0134	OC6217	0646817200		S				PRESSURE SWITCH; GP600		33,50
0135	OC5426	0513805000		S				STIRRUP		14,15

??????	267202								
??????	875400V00	???????? 3	Water system						
.		Alias		S			.		(Euro)
0136	0C6201	0546824100		S				PIVOT	1,02
0137	0C6375			S		Kit		FLOW REDUCER; KIT 4PCS	11,67
0138	0C6377			S		Kit		O-RING WITH BUSH; KIT	15,60
0139	0C6421	0219035015		S				SPRING RING	1,02
0140	0C7924	0505401R00						FIXING PLAQUE	6,22
0141	0C8348	0544400C01		S				RUBBER HOLDER; DIA.5MM 1/8"	
0142	0C7925	0543400R00		S				CABLE GROMMET; ØINT 24.6 ØEST 38	15,23
0143	0C2309	0546814600		S				TUBE; BY METER	6,66
0144	005382	0246530100		S				GROMMET; DIA.22	1,99
0145	0C5829	0544819400	0C4832	S				TUBE; BLU; 10X17; BY METER	
0146	0C8347	0686400100	0C9067					PUMP; 230-240V 50-60HZ; UL	
0147	0C8683	0835400L00		S				WATER INLET GROUP; 220 240V UL	122,80
0147	0C8684	0835400M00		S				WATER INLET GROUP; 220 240V UL	102,50
141a	0C9538	0546400J00		S				PROTECTING CAP; BLACK	

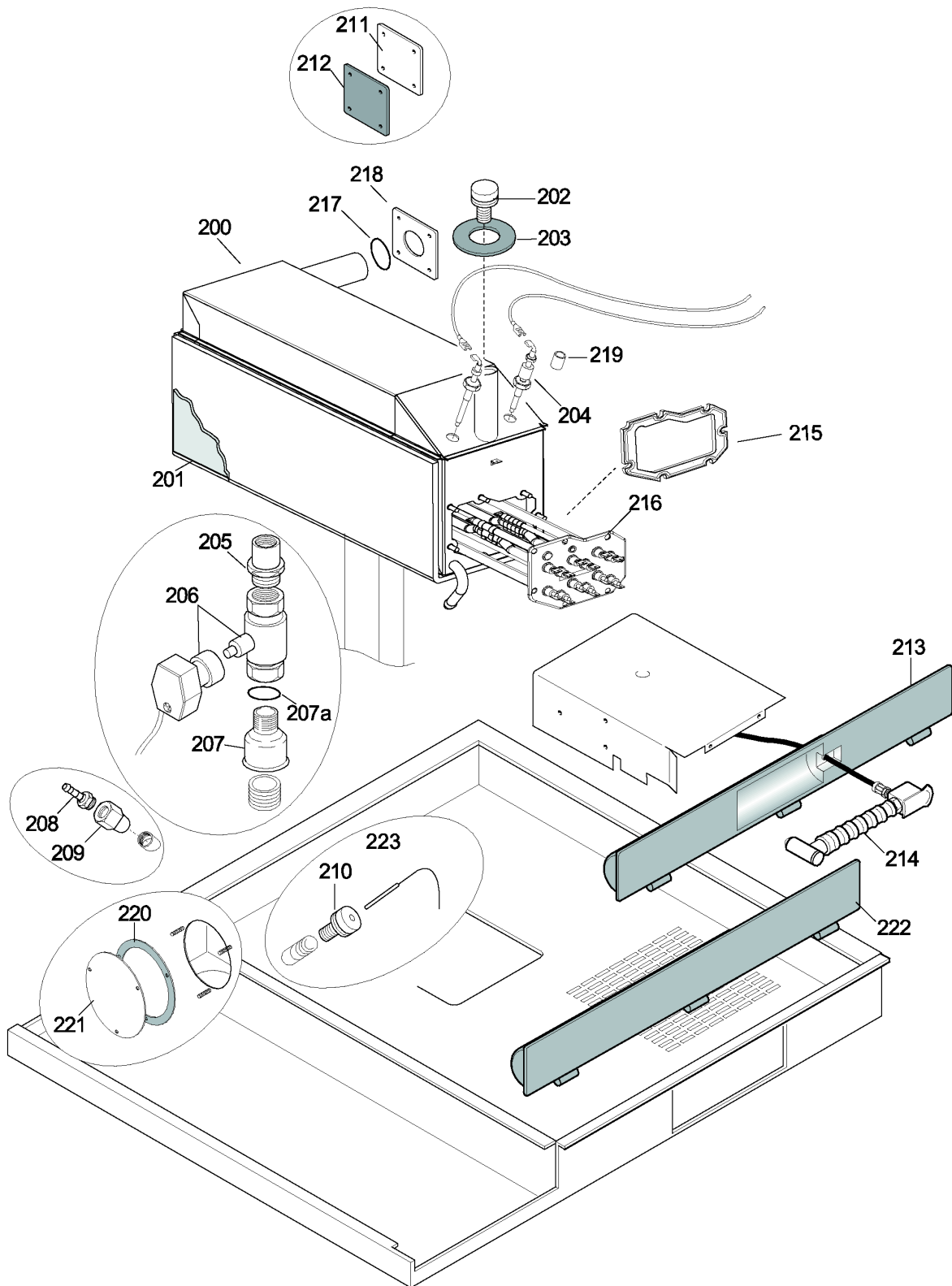

From sr. Nr/ Da Ser. Nr.: 014
 From status level / Da scatto: 07

Page: 4

Ed. 2014 03

Doc. Nr.: **875400V00**

??????	267202									
??????	875400V00	???????? 4	Boiler							
.		Alias		S			.			(Euro)
0200	0C5848	0831854701	0C5851					BOILER; ASSY; ELT ONE 6-101		
0200	0C5851	0831855501		S				BOILER; ASSY; 6-101 ELT. VERS. UK	For UK Version	642,00
0201	0C5836	0569806900						BOILER INSULATION; ELT ONE 061-101		107,60
0202	002692	0543816601		S				CAP; DESCALING LOAD IN THE BOILER		6,76
0203	0C5834	0543844800		S				GASKET; BOILER HEATING ELEMENT		19,69
0204	007033	0830890500		S		+		LEVEL PROBE; BOILER		32,99
0205	007117	0516809501		S				CONNECTION		15,81
0206	0C0882	0696804201		S				MOTOR-OPERATED VALVE; 3/4" 230V 50/60HZ		144,10
0206	0C5518	0696808500		S				BALL VALVE; 3/4' USA 240V 50/60HZ	For 60Hz Version	145,10
0207	0C3847	0511820300		S				REDUCING SLEEVE; 1"1/4F-3/4"M		17,11
0208	0C5564	0510828000		S				RUBBER HOLDER; 1/4"; FOR TUBE DIA.10MM		5,33
0209	0C4099	0516879600		S				NOZZLE; 1/4"FD3.5-3/8"M		18,88
0210	0C4872	0543842600		S				PLUG; FOR SENSOR		7,29
0211	0C4856	0527898700		S				FLANGE	For Level C,K	6,76
0212	0C4963	0543842800		S				GASKET; FOR BOILER	For Level C,K	19,54
0213	0C4532	0546815103						FRONT PANEL; LOWER; 6-10 1/1 AOSQ		92,16
0214	0C4248	0873881200		S				SHOWER UNIT; AOSQ		257,80
0215	0C5834	0543400900		S				GASKET; BOILER HEATING ELEMENT		19,69
0216	0C5821	0617837100		S				HEATING ELEMENT; 208V-16500W	For 208V Version	280,10
0216	0C5824	0617837700						HEATING ELEMENT; 240V-16500W	For 240V Version	275,10
0216	0C5840	0617836400		S				HEATING ELEMENT; 400V-17000W	For 400V Version	189,80
0216	0C5843	0617844800		S				HEATING ELEMENT; 230V-17000W	For 230V Version	223,30
0216	0C5846	0617838300		S				HEATING ELEMENT; 440V-17000W	For 440V Version	223,30
0216	0C6024	0617836900		S				HEATING ELEMENT; 200W-17000W	For 200V Version	283,20
0216	0C6939	0617400100						BOILER HEATING ELEMENT; 480V-16500W	For 480V Version	280,10
0217	002874	0543816800		S				O-RING; ØI=31,34X3,53 MM		3,48
0218	0C4821	0527898600		S				FLANGE		7,39
0219	055347	0515857001		S				SPACER; H=11,5MM		5,81
0220	0C7033	0543400000		S				GASKET	for level TOUCH	17,95
0221	0C3443	0J89061403						WASHER; FOR DOOR		15,84
0222	0C8597	0546821401						FRONT PANEL	For Level B	23,14
0223	0C6539	0830899101		S				THERMOCOUPLE PROBE; L=1100MM; STRAIGHT	for Level TOUCH e B	40,19
207a	002874	0543816800		S				O-RING; ØI=31,34X3,53 MM		3,48

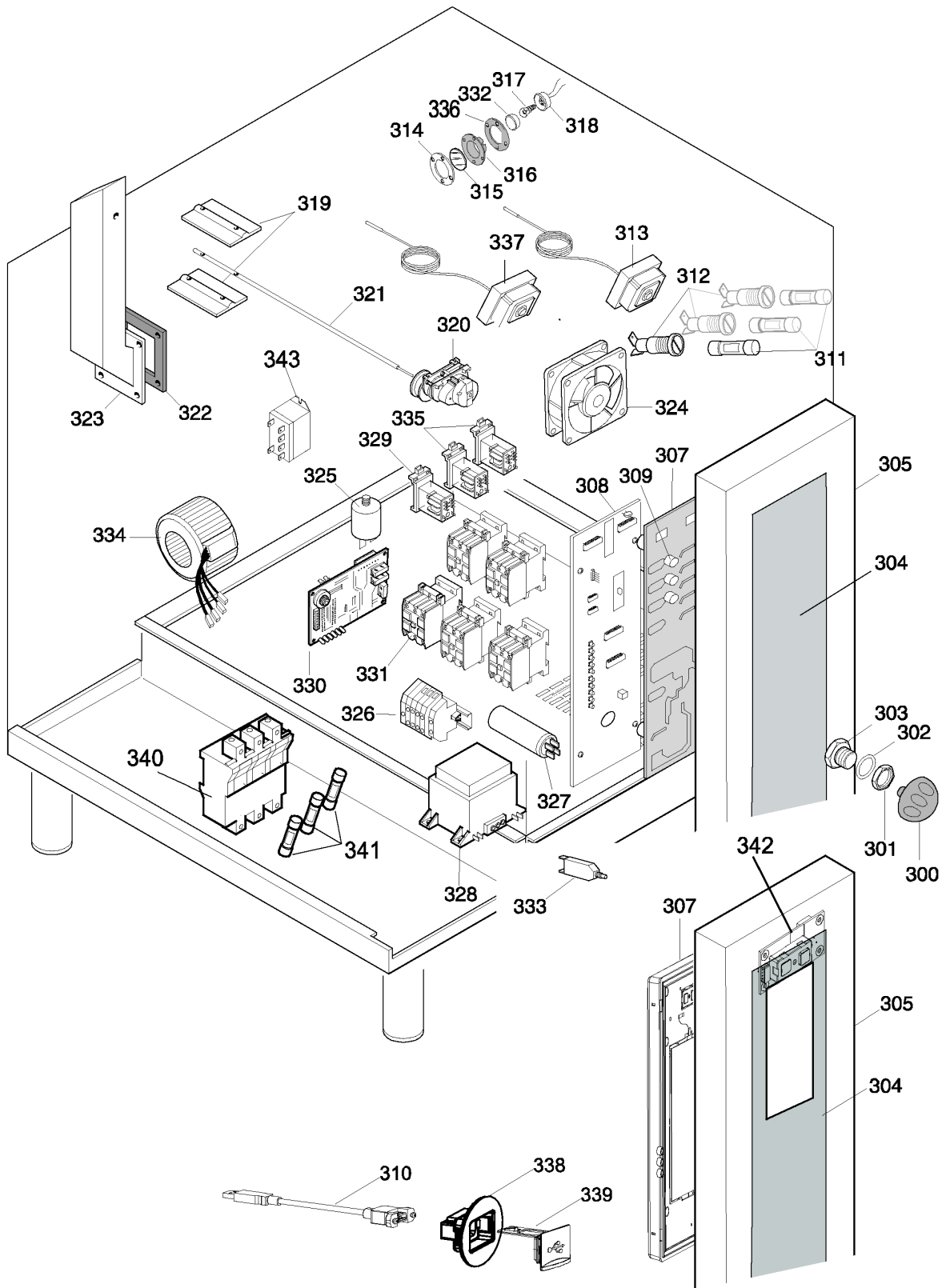

From sr. Nr/ Da Ser. Nr.: 014
 From status level / Da scatto: 07

Page: 5

Ed. 2014 03

Doc. Nr.: **875400V00**

??????	267202									
??????	875400V00	???????? 5	Electrical components							
.		Alias		S			.			(Euro)
0300	0C5600	0806874001	0C4875					KNOB	For level B, C,K	
0301	051263	0214114900		S				LOCK NUT	For level B, C,K	3,80
0302	002727	0508836400		S				WASHER	For level B, C,K	1,02
0303	002662	0516807301		S				BUSH	For level B, C,K	6,02
0304	0C4948	0675855002						ADHESIVE MEMBRANE; ONE; LIV.B	for Level B FCZ Group	67,90
0304	0C4949	0675855103						ADHESIVE MEMBRANE; ONE; LIV.C	for Level C FCZ Group	56,43
0304	0C6549	0548400500						ADHESIVE MEMBRANE	for TOUCH AOS Group	72,98
0304	0C6551	0548400B00						ADHESIVE MEMBRANE	for TOUCH FCZ Group	59,28
0304	0C6553	0548400F00						ADHESIVE MEMBRANE	for Level B AOS Group	65,37
0304	0C6556	0548400J00						ADHESIVE MEMBRANE	for Level C AOS Group	72,37
0304	0C7961	0675847601						ADHESIVE MEMBRANE	for Nando's Model	273,00
0304	0C8084	0548401900						ADHESIVE MEMBRANE; ONE 10 LIV.C	for Level C Bakery	285,20
0304	0C8706	0548401G00						ADHESIVE MEMBRANE; TOUCHSCREEN 10 ELUX '	For Level Touch "K" AOS Group	82,72
0305	0C4901	0873895902						CONTROL PANEL; ASSY; ONE 101 LIV.A	For Nando's Model	244,60
0305	0C4902	0873896002						CONTROL PANEL; ONE 101 LIV.B	for Level B FCZ Group	221,30
0305	0C4903	0873896102						CONTROL PANEL; ONE 101 LIV.C	for Level C FCZ Group	221,30
0305	0C6582	0870400501	0C7030					CONTROL PANEL; 101 TOUCH	for TOUCH AOS Group	
0305	0C6583	0870400600						CONTROL PANEL; 101 LIV.B	for Level B AOS Group	264,90
0305	0C6592	0870400J00						CONTROL PANEL	for TOUCH FCZ group	232,40
0305	0C6593	0870400K00						CONTROL PANEL; 101 LIV.C	for Level C AOS Group	264,90
0305	0C8711	0875401U00						CONTROL PANEL; COMPLETE W/MEMBRANE	For Level Touch "K" AOS Group	336,00
0307	0C0041	0675838802		S				USER INTERFACE; LIV B	for Level B	332,90
0307	0C0043	0675837904		S				USER INTERFACE BOARD; COPUI20-A; LEV.A	for Nando's model from to115..	604,00
0307	0C3915	0675847701						USER INTERFACE BOARD; USER INTERFACE NAN	for Nando's model up to 114...	691,00
0307	0C4891	0675854600			D	PDD2012-16		USER INTERFACE BOARD	for Level C	347,10
0307	0C6571	0675400A00	0C8805					USER INTERFACE BOARD; COPUI40-T	for Level TOUCH,K	
0307	0C7350	0675854602		S				USER INTERFACE BOARD	for level C (stard s/n 120...)	348,10
0308	0C0042	0005851401		S				POWER BOARD; COP20-A; LIV A/B/C LW	For Level B,C,Nando's up to 114... for Level B, C,Nando's from to 115...	588,00
0308	0C6570	0675400801		S				MOTHERBOARD; COP20-T	for Level TOUCH,K	426,30
0309	0C3750	0546814001	0C3751	S				SPACER; 6.6	for Level B, C ,K	
0309	0C5833	0546824600						BUTTON EXTENSION; L=7,4MM	for Level B, C,K	1,02
0309	0C6564	0633847400						SHIELDED CABLE	for TOUCH level	24,26
0310	0C6565	0638400P00						EXTENSION CABLE	for TOUCH level	14,15
0310	0C6566	0638400Y00		S				USB EXTENSION; L=340MM	for TOUCH level	12,46
0311	058871	0652800901		S				FUSE; 6,3A; 5X20; QUICK ACTING	For 400V; 230V	1,02

??????	267202									
??????	875400V00	???????? 5	Electrical components							
.		Alias		S			.			(Euro)
0311	0C1480	0652803300		S				FUSE; 5*20 6,3A T; USA	For 208V; 240V ; 480V	1,25
0311	0C1480	0652803300		S				FUSE; 5*20 6,3A T; USA	For E,F1	1,25
0311	0C2230	0652805100		S				FUSE; 6,3*32 FAST 6,3A 500V OMEGA GF6322	For Marine Version	4,22
0311	0C2236	0652805200						FUSE; 1.6A FAST 5X20 WEBER 0401601	For 200V	1,92
0311	0C2301	0652803900		S				FUSE; OMEGA 800MA (COD. ST22180)	For 400V; 230V	1,27
0311	0C3650	0652804900	0C3651					FUSE; 6,3X32 FAST 3,15A 500V	For Marine Version	
0311	0C4996	0652806100		S				FUSE; 3,15A 5X20; TIME-LAG		1,36
0311	0C6034	0652803100						FUSE; TIME-LAG; 5X20 T1.6A	For 200V	1,27
0311	0C6946	0652400000						FUSE; 500V-3,15A; 6,3X32MM	For 480V	5,49
0312	0C2228	0652804800		S				FUSE CARRIER; SCHURTER FEC 0031.1631+003	For Marine Version	18,09
0312	0F0031	0652802100		S				FUSE CARRIER	For 400V; 230V	16,08
0313	006314	0646810802		S				SAFETY THERMOSTAT; 338 C	For 60Hz Version	121,80
0313	007042	0646812200		S	C			SAFETY THERMOSTAT; 357°C		93,15
0314	002628	0508840801		S				FLANGE		4,01
0315	002627	0574804900		S		+		LAMP GLASS		10,24
0316	002626	0543817202		S		+		LAMP HOLDER GASKET		15,39
0317	0C4396	0660808300	0C9877	S	C			HALOGEN LAMP; 12V-10W 300GR C.		
0318	007055	0660806401		S				LAMP HOLDER		21,72
0319	007081	0508896801						JALOUSIE		18,98
0320	0C5501	0680802300	0C0883					GEARMOTOR; 230V-50HZ		
0320	0C5502	0680802400	0C1479					GEARMOTOR; 24V-60HZ; USA	For 60Hz Version	
0321	0C5525	0856832702						STEM; 6-10 1/1 ELECTRIC		18,69
0322	007053	0543828600		S				GASKET		19,54
0323	0C5528	0831855200						AIR DUCT; ASSY; 10 1/1 ELETRIC		63,74
0324	0C4106	0624811000		S				FAN; 220/240V 50/60HZ		37,76
0325	049303	0694605400		S				RADIO INTERFERENCE FILTER; 250V 50/60HZ		23,55
0326	0C6028	0639813100			D			TERMINAL BOARD; TXM60	For 200V Version	80,69
0326	0F0112	0639808600		S				TERMINAL BOARD		28,62
0327	047541	0694604400		S				CAPACITOR; 12,5MF	For Level TOUCH, B	12,31
0327	0C5526	0694806000		S				CAPACITOR; 8 MF	For Level C ,K	13,73
0328	007046	0624807100	0C9865					TRANSFORMER;100/200/230V 12/24V 50/60HZ	For 200V Version	45,67
0328	0C0949	0624807700						TRANSFORMER	For Marine Version	163,40
0328	0C6400	0624400100		S		Kit		TRANSFORMER; KIT		76,73
0329	058857	0648803001		S				RELAY		25,12
0329	088267	0648722900		S				RELAY; COIL 200-240VAC	For 60Hz Version	39,18
0330	007047	0624807002		S				POWER SUPPLY BOARD; LAMBDA PROBE		145,10

??????	267202									
??????	875400V00	???????? 5	Electrical components							
.		Alias		S			.			(Euro)
0331	006879	0648807400		S	C			CONTACTOR; 220-240V 50HZ/240-264V 60HZ		37,68
0331	007080	0648807700		S	C			CONTACTOR; 220-240V 50HZ/240-264 60HZ	For 230V; 200V; 208V; 240V	79,89
0331	088477	0648807300		S	C			CONTACTOR; 220-240V 50HZ/240-264V 60HZ	For 400V Version	28,84
0331	088557	0648400000		S	C			CONTACTOR; 220-230V 50HZ/240V 60HZ	For 480V	35,47
0331	0L0355	0648613200		S	C	+		CONTACTOR; 220-240V 50HZ/240-264V 60HZ	For 480V	68,73
0332	0C4459	0509803900		S				LAMP CAP		5,91
0333	056466	0648802601		S				RELAY	For Marine Version	26,29
0334	0C6945	0624400000		S				TRANSFORMER; 450VA 12/24/120/208/220/240	For USA models	218,20
0335	056466	0648802601		S				RELAY	For 60Hz Version	26,29
0336	0C5451	0543843500		S				LAMP HOLDER GASKET		4,54
0337	0C2983	0646814900		S	C			OVERTEMPERATURE LIMITER; 140GR 3P	For Level TOUCH, B	82,80
0338	0C6547	0546400200		S				BOWL; FOR USB	for TOUCH level	3,17
0339	0C6546	0541400A00		S				PLUG; PER USB	for TOUCH level	5,29
0340	000000									
0341	000000									
0342	0C8033	0675858601		S				BUTTON; 0/I; TOUCH		52,27
0343	088267	0648722900		S				RELAY; COIL 200-240VAC	For TOUCH level	39,18

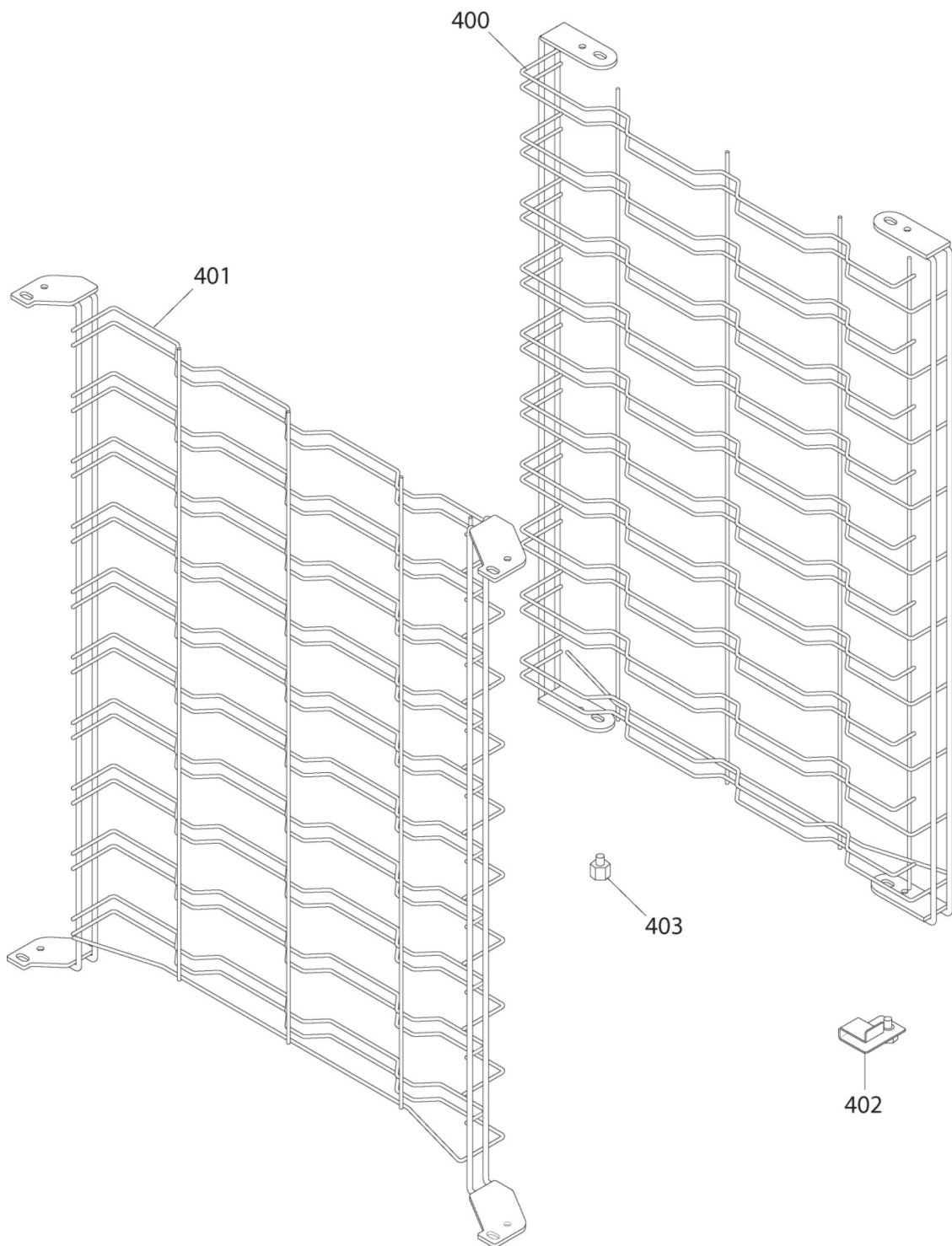

??????	267202									
??????	875400V00	???????? 6	Accessories							
.		Alias		S			.		(Euro)	
0400	0C4862	0831849200						CHROME GRID; DX ONE 101	For P 60 Version	119,80
0400	0C5015	0831852400						CHROME GRID; DX ONE 061	For P 80 Version	91,86
0401	0C4861	0831848900						CHROME GRID; SX ONE 101	For P 60 Version	126,90
0401	0C5014	0831852300						CHROME GRID; SX ONE 061	For P 80 Version	96,63
0402	0C4961	0806872800		S				SUPPORT		27,51
0403	0C0325	0830899001		S				TEMP.PROBE; THERMOCOUPLE; L=85CM; BOILER	for Level TOUCH e B	39,89
0403	0C1567	0527839102						SUPPORT; RH	For Marine Version	32,28
0403	0C1568	0527839202						SUPPORT; LH	For Marine Version	38,16
0403	0C3458	0853852705						PAN HOLDER STRUCTURE; ASSY LW10	For Marine Version	348,10
0403	0C5620	0511828100		S				BAKING PAN SUPPORT		11,41
0403	0C6539	0830899101		S				THERMOCOUPLE PROBE; L=1100MM; STRAIGHT	for Level TOUCH e B	40,19
0403	0C7028	0830400N00		S				SENSOR		42,12