

LAVASTOVIGLIE A CESTO TRASCINATO - 1 Vasca
RACK TYPE DISHWASHER - 1 Tank

RT 10 / RT 180 / Z 18 / WT 90
ELECTRIC HEATED

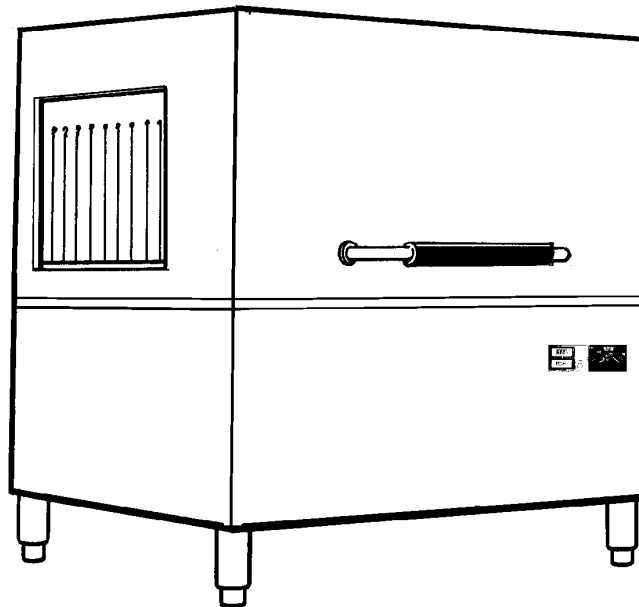

Pag.	Illustr.	Indice Descrizione	Index Description
2	21315	Vasca e pannelli	Tank and panels
3	21316	Scarico ed impianto di lavaggio	Drain and wash system
4	21317	Componenti elettrici	Electric components
5	21318	Unità condensa fumane CU	Condensing Unit CU
6-10		Lista ricambi	Spare part list

Marchio / Brand: Tutti / All
Paese / Country: Tutti / All

Da Ser. Nr. / From ser. nr.: 736 /

Page: 1

Ed. 0107

Doc. Nr.:

6-50 001

OS/Doc - RT 10 \ 650001.pm6 (Doc No 478 2034-17)

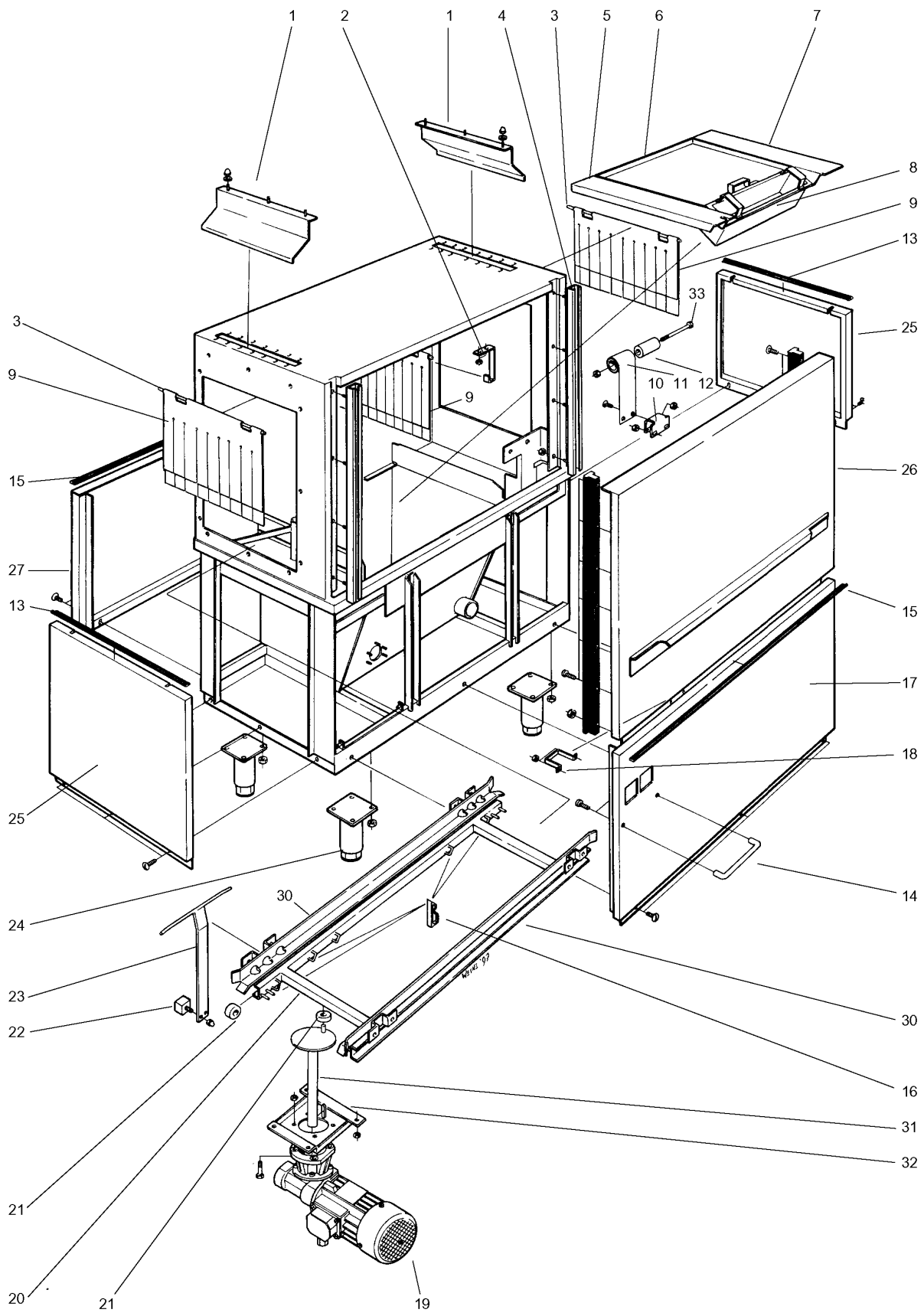

ill. 21315

??????	533315									
??????	6-50001	???????? 2	Tank and panels							
.		Alias		S			.			(Euro)
0001	0E5824	RT0027200						SPLASH GUARD		24,87
0002	0E5825	RT0003800	0L0559		D	CGX200 5-03		ATTACHMENT; FOR CURTAIN		
0003	0E5826	RT0003700		S				CURTAIN AXIS; L=580 MM		16,80
0004	000000	RT0003600							art. RT0003600	
0005	0E5821	RT0005700						SIDE PLATE; LEFT, FOR FILTER		56,54
0006	0E5472	W00183500						STRAINER PLATE		141,10
0007	0E5827	RT0005800						SIDE PLATE; RIGHT, FOR FILTER		56,54
0008	0E5183	W00102700		S				STRAINER BASKET		134,00
0009	0E5828	RT0003900	0E6006					CURTAIN		
0010	0E2898	W00143600		S				SPRING RETAINER		14,89
0011	0E5167	W00093300		S				SPRING BLADE; 38X0,5 MM		56,10
0012	0E5001	W00093100		S				PULLEY		9,82
0013	0E5829	W00444100						GASKET		
0014	0E5830	RT0005300						PROTECTION; FOR HANDLE		19,08
0015	0E5829	W00444100						GASKET		
0016	0E5007	W00093000	0K8166					FINGER F. BASKET FEEDING		
0017	0E5831	RT0017900						FRONT PANEL		
0018	0E5832	RT0016200						SUPPORT BRACKET		14,58
0019	0E5833	RT0029800		S				RACK FEEDING MOTOR; 230-400V 50/60HZ		612,00
0019	0E5963	611619900						GEARMOTOR	ASIAN	638,00
0020	0E5834	RT0019800						FEEDING LADDER		239,50
0021	0E5046	W00017300	0K7281					ROLL		
0022	0E0102	W00003700	088361			CGX200 2-12		MAGNET		
0023	049857	835618600		S				GROUND TERMINAL; RIGHT	From to ser.128	45,07
0023	049858	835618700		S				GROUND TERMINAL; LEFT	From to ser.128	40,90
0023	0E5835	RT0013700		S				MICRO ACTUATOR	Up to ser.127	49,94
0024	0E5009	W00094500		S				FOOT		30,15
0025	0E5820	RT0017800						SIDE PANEL		401,90
0026	0E5836	RT0015600								
0027	0E5837	RT0017600						REAR PANEL		212,10
0030	0E5838	RT0018700						SLIDE; FOR BASKET		112,70
0031	0E5839	RT0019400						DRIVE AXIS		108,60
0032	0E5840	RT0003400						PLATE; MOTOR FITTING		65,37
0033	0E5792	W00516700		S				SCREW		1,78

OS/Doc - RT 10 \ 650001.pm6 (Doc No 478 2034-17)

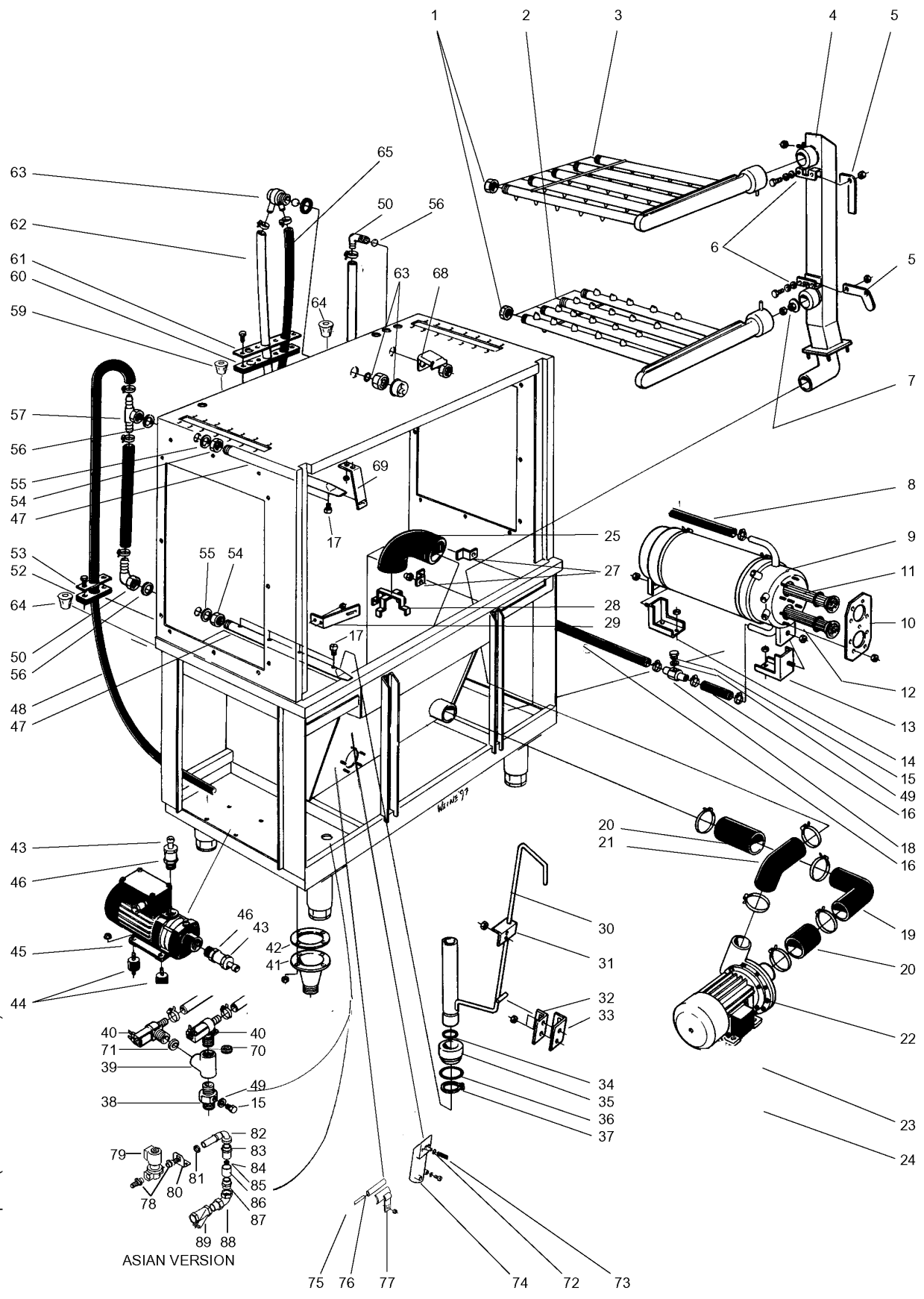

ill. 21316a

Da Ser. Nr. / From ser. nr.: 736 /	Page: 3	Ed. 0004	Doc. Nr.: 6-50 001
---	---------	----------	---------------------------

??????	533315									
??????	6-50001		???????? 3				Drain and wash system			
.		Alias		S			.			(Euro)
0001	0E5016	W00527600		S			CAP; 1" F; WASH ARMS	Up to Ser: 028		19,32
0001	0E5997	805656100		S			PLUG; FOR WASH ARM	From Ser: 029		4,33
0002	0E5465	W00384900	0E5995				WASH ARM; LOWER	Up to Ser: 028		
0002	0E5995	RT0057101					WASHING JET; 5 ARMS	From Ser: 029		260,90
0003	0E5467	W00384800	0E5994				WASH ARM; UPPER	Up to Ser: 028		
0003	0E5994	RT0055501	0E6024				FEED PIPE	From Ser: 029		
0004	0E5680	W00094400		S			PIPE; JETS CONNECTION			231,40
0005	0E5469	W00140700	0KU309				LOCK HANDLE			
0006	0E5714	W00511600		S			GASKET			1,59
0007	0E5179	W00115600					FLOW REDUCER			16,79
0008	0E5509	W00499400		S			RUBBER HOSE; ØI=15MM; ØE=23MM; BY METER			18,56
0009	0E5841	RT0032600				CGX200 0-05	BOILER	Vertical elements - Up to Ser: 004		1 378,00
0009	0E5954	850653401	0L1856	S		+	BOILER	Horizontal elements - From Ser: 005		
0010	0E5492	W00023102		S			FLANGE	From Ser: 005		19,39
0010	0E5534	W00104800		S		CGX200 0-46	FLANGE	Up to Ser: 004		41,01
0011	049116		0L1878	S		+	BOILER HEATING ELEMENT; 6000W 230V	Without CU - From Ser: 005		
0011	0E5066	W00120100	0L1836	S		+	CGX200 0-46	HEATING ELEMENT; 10KW 230V	With CU - Up to Ser: 004	
0011	0E5114	W00120300	0K8249				CGX200 0-46	HEATING ELEMENT; 230V 6KW, 460MM	Without CU - Up to Ser: 004	
0011	0E5953	617613000	0L1852	S		+		BOILER HEATING ELEMENT; 10500W 230V	With CU - From Ser: 005	
0011	0E5953	617613000	0L1852	S		+		BOILER HEATING ELEMENT; 10500W 230V	Without CU;ASIAN - From Ser: 005	
0011	0E5956	617614000	0L1853			+		HEATING ELEMENT; 230V 12000W	Without CU;ASIAN - Up to Ser: 004	
0012	0E5066	W00120100	0L1836	S		+	CGX200 0-46	HEATING ELEMENT; 10KW 230V	Without CU - Up to Ser: 004	
0012	0E5116	W00120500	0L1837	S		+	CGX200 0-46	BOILER HEATING ELEMENT; 230V 12KW 460MM	With CU - Up to Ser: 004	
0012	0E5953	617613000	0L1852	S		+		BOILER HEATING ELEMENT; 10500W 230V	With CU - From Ser: 005	
0012	0E5953	617613000	0L1852	S		+		BOILER HEATING ELEMENT; 10500W 230V	Without CU - From Ser: 005	
0012	0E5953	617613000	0L1852	S		+		BOILER HEATING ELEMENT; 10500W 230V	Without CU;ASIAN - From Ser: 005	
0012	0E5956	617614000	0L1853			+		HEATING ELEMENT; 230V 12000W	Without CU;ASIAN - Up to Ser: 004	
0013	0E5695	W00187500				D	CGX200 0-46	BRACKET		
0014	0E5694	W00187400					CGX200 0-46	BRACKET		20,81
0015	0E2887	W00527200						PLUG; 1/8"		5,70
0016	0E5509	W00499400		S				RUBBER HOSE; ØI=15MM; ØE=23MM; BY METER		18,56
0017	0E5148	W00136400		S				NOZZLE; N°9504; FOR RINSING		16,34
0018	0E3080	W00502600		S				HOSE NIPPLE		18,27
0019	0E2969	W00233700		S				ELBOW PIPE		36,34
0020	000000	544629200						ASIAN		
0020	0E5023	W00019200		S				RUBBER HOSE		17,30

??????	533315								
??????	6-50001		???????? 3				Drain and wash system		
.		Alias		S			.		(Euro)
0021	0E2970	W00132300		S				HOSE; RUBBER	41,41
0022	0E5335	W00186500	0L0437		D	60013		PUMP; WASHING 380-415V 50HZ	
0022	0E5962	611618600						PUMP; 230-240/400-415V 3HP *	800,00
0023	000000								
0024	000000								
0025	0E5474	W00234200		S				SUCTION HOSE	42,43
0027	0E5475	W00114900						BRACKET	11,30
0028	0E5476	W00248400						CROSS; SUCTION PROTECTION	19,89
0029	0E5058	W00127200						SPRING; FOR RINSE ARMS	15,62
0030	0E5020	W00104700	0L1880	S		+		OVERFLOW PIPE; COMPL.	
0031	0E5822	RT0005600						BRACKET	6,97
0032	0E5686	W00112400		S				BRACKET; LEFT GUIDE	10,04
0033	0E5685	W00112300		S				BRACKET; RIGHT GUIDE	10,04
0034	0E0142	W00524700		S				O-RING; ØI=29X3 MM	1,02
0035	0E0141	W00008400	0L1863	S		+		DRAIN CAP	
0036	0E0010	W00008900		S				O-RING; ØI=44.2X5.7 MM	5,73
0037	0E5152	W00522900		S				SNAP RING	4,47
0038	0E5523	W00504500						NIPPLE; 3/4" M	41,21
0039	0E5522	W00528200						NIPPLE T; 3/4" F	18,88
0040	0E5842	RT0029900			D	60024		SOLENOID VALVE	
0041	0E0113	W00008500	0K7046					STRAINER WASTE	
0042	0E0112	W00017700		S				GASKET; FOR DRAIN	4,96
0043	0E5513	W00504100		S				HOSE NIPPLE; 1/2"	48,82
0044	0E0129	W00004900		S		CGX200 0-56		SHOCK ABSORBER	7,92
0045	0E5532	W00068800		S				BOOSTER PUMP; 220-240V 1P 50HZ	600,00
0046	0E5531	W00526700						NIPPLE; 3/4"	12,41
0047	0E5506	W00303800		S				RINSE ARM	58,67
0048	0E5509	W00499400		S				RUBBER HOSE; ØI=15MM; ØE=23MM; BY METER	18,56
0049	0E5524	W00500500		S				GASKET	1,02
0050	0E5510	W00504600	0K8721					BOW	
0052	0E5843	RT0004300						GASKET; HOSE INLET	6,05
0053	0E5844	RT0004500						PLATE; HOSE INLET	4,07
0054	0E5507	W00303700		S				SLEEVE; FOR RINSE ARMS	22,84
0055	0E5118	W00524500		S				O-RING; DI=17,3MM; DE=22,1MM	1,02
0056	0E5122	W00500800	0L2402					GASKET	
0057	0E5508	W00504700	0K8722					T-CONNECTOR	

??????	533315									
??????	6-50001	???????? 3					Drain and wash system			
.		Alias		S			.			(Euro)
0059	0E5823	RT0005500						CABLE GROMMET		2,43
0060	0E5845	RT0004400						GASKET; HOSE INLET		10,67
0061	0E5846	RT0004600						PLATE; HOSE INLET		6,86
0062	0E5121	W00499300	048531					HOSE		
0063	0E5648	W00493800	049332					NON RETURN VALVE COMPL; DVGW		
0064	0E5847	RT0005400						CABLE GROMMET		
0065	0E5509	W00499400		S				RUBBER HOSE; ØI=15MM; ØE=23MM; BY METER		18,56
0068	0E5848	RT0011900						SPLASH GUARD		18,37
0069	0E5505	W00107700		S				SPRING; FOR RINSE ARMS		20,50
0070	0E5526	W00126000					CGX200 2-05	RED INLET REDUCER; 20 L/M; RED		1,38
0071	0E5528	W00126100					CGX200 2-05	YELLOW INLET REDUCER; 5,5L/ MIN		1,00
0072	0E5360	RT0012400	0E2836		D			O-RING		
0073	072393	W00537200		S				HOSE; Ø=4X7,4MM; L=500CM; PRESSURE SWITC		11,67
0074	0H2542	W00498600	046631		D			AIR TRAP		
0075	0E5032	W00008200		S	C			THERMOSTAT; 30-110 C		56,97
0076	0E5479	W00237400						SLEEVE INSULATION		12,04
0077	0E5480	W00018400	0K7406					BRACKET		
0078	049508	514679400						RUBBER HOLDER	ASIAN	89,83
0079	049509	696613300						SOLENOID VALVE; 3/8" 230V 50HZ	ASIAN	111,70
0080	000000	507609400							ASIAN	
0081	049516	514679300						NUT	ASIAN	7,00
0082	049232	830625700			D			HOSE	ASIAN	10,51
0083	049510	515647501						NIPPLE	ASIAN	20,16
0084	0E5961	549642000		S				SHUTTER	Boiler; ASIAN	4,06
0085	048742	549620800						SHUTTER	Tank; ASIAN	4,06
0086	0E5525	W00526000						SLEEVE	ASIAN	15,42
0087	000000	W00562300							ASIAN	
0088	0E5609	W00511800						PIPE FITTING	ASIAN	35,83
0089	068121	330700014		S		06006		FILTER	ASIAN	56,84

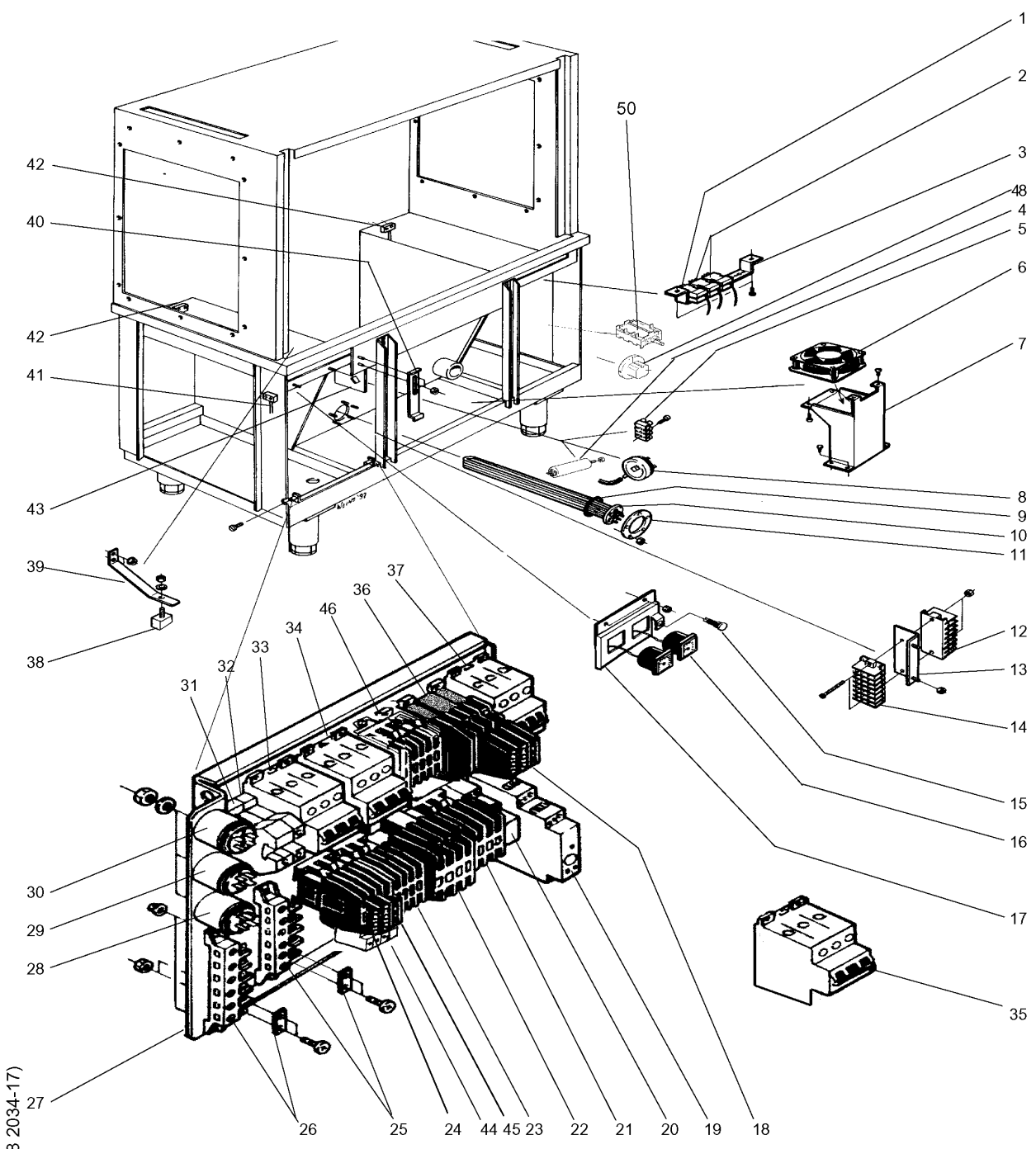

OS/Doc - RT 10 \ 650001.pm6 (Doc No 478 2034-17)

ill. 21317

Da Ser. Nr. / From ser. nr.: 736 /	Page: 4	Ed. 0107	Doc. Nr.: 6-50 001
---	---------	----------	---------------------------

??????	533315									
??????	6-50001		???????? 4				Electric components			
.		Alias		S			.			(Euro)
0001	0E5086	W00050400		S				SAFETY THERMOSTAT; 126°C		66,32
0002	0E5032	W00008200		S	C			THERMOSTAT; 30-110 C		56,97
0003	0E5724	W00126600						SUPPORT		20,17
0004	0E0174	W00533200		S				CAPACITOR; 2MF	With CU	10,08
0005	0E5178	W00126500						CONNECTION BLOCK; 3 POLES		8,44
0006	0E2261	W00019500	0C4106	S				FAN; 230V 1P 50/60HZ 7,5W		
0007	000000	RT0004000								
0008	0E5565	W00393800	0E3731					PRESSURE SWITCH; LEV. 40/15-55/35		
0009	0E5037	W00525000		S	C		CGX200 0-46	HEATING ELEMENT GASKET;DIA.56,52XSP.5,33		1,43
0010	0E5161	W00119500	0L1859	S		+		HEATING ELEMENT; 7500W 230V	RT10-RT180-Z18 - Without CU	
0010	0E5163	W00119400	0L1860	S		+		HEATING ELEMENT; 9KW 230V	RT10-RT180-Z18 - With CU	
0010	0E5163	W00119400	0L1860	S		+		HEATING ELEMENT; 9KW 230V	WT90	
0011	0E5492	W00023100		S				FLANGE		19,39
0012	0E5176	W00033300	046347					TERMINAL BOARD	X13	
0013	000000	W00166300								
0014	0E5176	W00033300	046347					TERMINAL BOARD	X14	
0015	0H2633	RT0031600	0K9096					LAMP; WHITE		
0016	048525	657601800		S				THERMOMETER		27,41
0017	000000	RT0004700								
0018	048497	640608500		S	C			AUXILIARY CONTACT		8,90
0019	0E5669	W00506200		S				TIMER; 24-240V 50/60HZ	With CU	111,70
0020	0E5173	W00502100						RELAY BASE		15,70
0020	0E5849	RT0030400		S				RELAY; 2 CONT. 230V	K14	22,94
0021	0W0632	W00534900	003598					CONTACTOR; 220V 10A		
0022	0W0690	RT0031900	054928					CONTACTOR; K2-23A10 230		
0023	0W0632	W00534900	003598					CONTACTOR; 220V 10A		
0024	0W0632	W00534900	003598					CONTACTOR; 220V 10A		
0025	0E5176	W00033300	046347					TERMINAL BOARD	X9	
0026	0E5176	W00033300	046347					TERMINAL BOARD	X2	
0027	000000	RT0004900								
0028	046226	W00225500		S				RFI FILTER; WITH FAST-ON		9,24
0029	046226	W00225500		S				RFI FILTER; WITH FAST-ON		9,24
0030	046226	W00225500		S				RFI FILTER; WITH FAST-ON		9,24
0031	0E5850	W00508400	0F0112					CONNECTION; NEUTRAL		
0032	0E5851	W00509000						CONNECTION; EARTH		21,52
0033	0E2309	W00506700	0E5894					AUTOMATIC FUSE; 10A 3-P	F4	

??????	533315									
??????	6-50001		???????? 4				Electric components			
.		Alias		S			.			(Euro)
0034	0E5452	W00507300	0KT674				AUTOMATIC FUSE; 50A 3-P	F8		
0035	0E5452	W00507300	0KT674				AUTOMATIC FUSE; 50A 3-P	F9, x 230V		
0036	0W0690	RT0031900	054928				CONTACTOR; K2-23A10 230	K108		
0037	0E2269	W00506800	0K8729		D		AUTOMATIC FUSE; 16A 3-P	F10, with HAB		
0038	0E0102	W00003700	088361			CGX200 2-12	MAGNET			
0039	0E5852	RT0017300					SPRING			38,98
0040	0E5853	RT0005200					BRACKET			13,30
0041	0E0003	W00011700	049966			CGX200 2-12	SWITCH; REED			
0042	0E5854	RT0029500	049969			CGX200 2-12	SWITCH; REED	2pcs with Autostart		
0043	000000	RT0005000								
0044	0E5220	W00535600		S			OVERHEAT PROTECTOR; 4-6 A	ASIAN - without CU		46,69
0045	046995	640605400		S	C		AUXILIARY CONTACT			4,45
0046	075796	648608400	048519			03207	CONTACTOR	K11		
0048	048402	548616600		S			KNOB; ØE=44MM; Ø PERNO=6MM	Zanussi		9,45
0048	048920	548621600					KNOB	Alpeninox		14,43
0048	0E3019	W00048900		S			KNOB	Electrolux		11,41
0050	048271	641603202		S			SELECTOR; 3 CAMMES	From Ser. n.: 905		36,17
0050	0E5132	641603202		S	C		SELECTOR; 3-P	Up to Ser. n.: 904		23,81

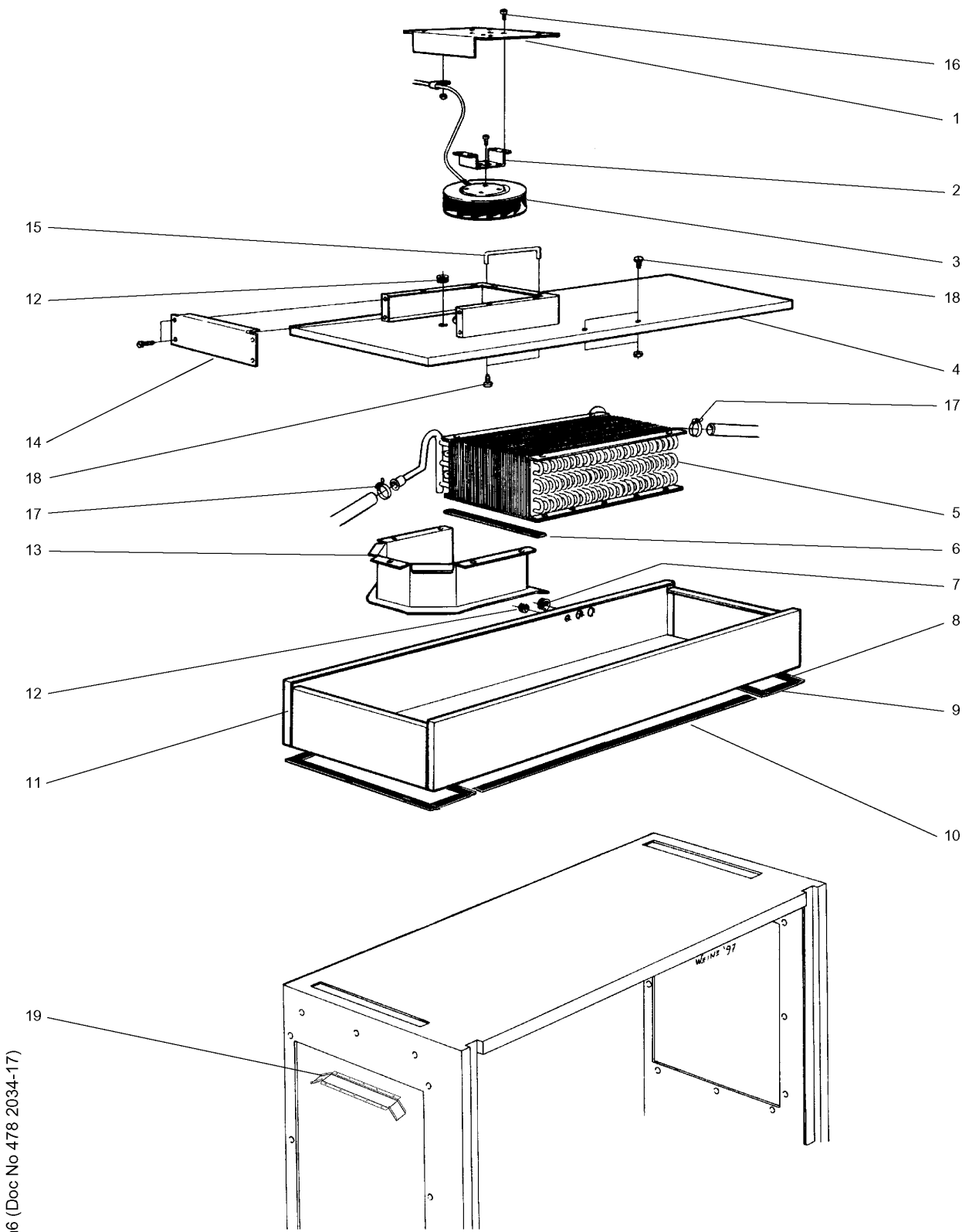

ill. 21318

OS/Doc - RT 10 \ 650001.pm6 (Doc No 478 2034-17)

??????	533315								
??????	6-50001	???????? 5	Condensing Unit CU						
.		Alias		S		.			(Euro)
0001	0E5775	W00467700					COVER; FOR FAN		
0002	0E5670	W00467800					SUPPORT		
0003	0E5666	W00431000		S			FAN		206,00
0004	0E5855	RT0022500					LID		50,14
0005	0E5581	W00209700		S			EXCHANGER; CONDENSING UNIT		685,00
0006	0E5225	W00536100		S			GASKET; 1PC=1000MM	L=210	3,69
0007	0E5585	W00499900	0E2365				CABLE GROMMET		
0008	0E5225	W00536100		S			GASKET; 1PC=1000MM	L=440	3,69
0009	0E5225	W00536100		S			GASKET; 1PC=1000MM	L=175	3,69
0010	0E5225	W00536100		S			GASKET; 1PC=1000MM	L=1200	3,69
0011	0E5856	RT0048300							
0012	0E2331	W00530300		S			CABLE GROMMET		1,80
0013	000000								
0014	0E5577	W00214700					CLOSURE PLATE; FOR FAN		28,72
0015	0E5830	RT0005300					PROTECTION; FOR HANDLE		19,08
0016	0H2300								
0017	000000	W00505300							
0018	000000	W00510500							
0019	0E5770	W00243200					DRIP GUARD		37,86