

eloma



**Provers
ES 120, ES 160**

Installation and Operation Manual

Installation- and Operation Manual

Provers ES 120 ; ES 160

Dear Customer,

Prior to taking the appliance into service, please do read this manual carefully.
It contains very important information on installation and operation of the appliance.

Table of contents

1. Hints on operational safety	2
2. Installation instructions	2
2.1 Setting up.....	2
2.2 Electrical connection.....	2
2.3 Connect water supply	3
3. Touch key panel	3
3.1 Functional description touch keys:	3
4. Starting the appliance (supervised operation).....	4
5. Cleaning	4
6. Trouble shooting.....	5
7. Data of the appliance	5
9. Warranty Conditions	6
Declaration of Conformity	7
Dimensioned sketch	

Article No. 900152 - 10/97

Legend : LED = Pilot lamp

Use for intended purpose

The appliance shall only be used for its intended purpose, namely the professional preparation of food.

1. Hints on operational safety

Installation



Follow the local regulations of the electricity supply companies and observe the instructions for the installation of kitchen equipment, as well as those given in the German Standards DIN 1988, part 4 and DIN 1986 part 1.

Do not install the appliance near to heat sources. Keep sufficient clearance to other units.

Operation

The appliance shall only be operated

- by trained staff
- for its intended purpose, as outlined in this operation manual
- when there are no defects.

Only approved specialists shall do maintenance and repair work on the warming cabinet. In case of operating trouble, disconnect the oven from the mains, close water tap and call the after-sales service.

To avoid accidents the door lock has to be removed when dismantling and destroying the appliance.

Noise level

The emission value of the noise level is less than 70 dB (A).

2. Installation instructions

2.1 Setting up

It is mandatory to set up the oven in a horizontal position. True up minor unevenness with the vertically adjustable supports, a combination of casters and feet. To change from feet to casters turn the star-shaped red wheel counterclockwise.

2.2 Electrical connection

The warming cabinet is ready for plug connection to a 230 V AC socket. We recommend to install an earth-leakage circuit breaker.

Potentialausgleich
compensation de potentiel
potential equalisation



The unit must be incorporated into the potential equalisation system (earthing) according to VDE. Terminal under indication plate.

2.3 Connect water supply

The appliance is equipped with a G ¾ A water connection. Use a pressure-resistant, flexible hose 1/2" .

Maximum water temperature 50 ° C

Minimum water pressure : 200 kPa = 2 bar

Maximum water pressure : 600 kPa = 6 bar

In case of differing water pressure values a pressure-regulator must be installed.
It is recommended to insert a mudguard.

We recommend to connect the appliance to soft water.

3. Touch key panel

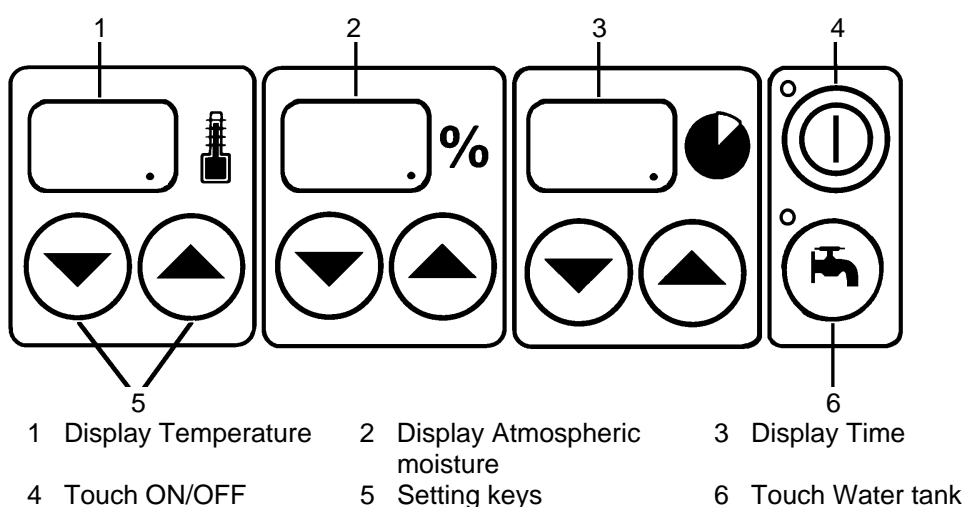

3.1 Functional description touch keys:

Touch ON / OFF



LED is lit, the appliance is ready for operation

Setting keys



Setting keys, forward and backwards. First slow then faster forward and backward setting or precise setting of values.

Display Temperature



Temperature range 30°C to 90°C
As long as the heating is on, the LED in the temperature display is lit.

Display Atmospheric moisture



Possible percentage from 40% to 90%, to be set in 5% steps.
As long as the heating in the water tank is on, the LED in the display is lit.

If this touch key  is pressed when 40% is indicated, display goes to 00, the humidification is stopped.

Display



Time, *Timer*

The timer is working separately from the operation, it does not switch off the appliance .

Time range 0 - 99 minutes, to be adjusted with the setting keys. After setting, the time runs down automatically, LED is flashing, and at the end there is a sound signal. Whatever time is set, it may be changed at any time.

Touch



Filling water tank

Water shortage is indicated : LED is lit, sound signal.

Press this key for manual water supply, however, this is normally not necessary since the water tank is filled automatically. Check if tap is open.

4. Starting the appliance (supervised operation)



Prior to starting, **open the water tap**
The water tank is filled automatically.

-  Press touch key ON/OFF. LED is lit, the appliance is ready for operation.
- Set the temperature
- Select the desired atmospheric moisture
- The appliance should be preheated for about 15 minutes.
- Charge the cabinet and close the door.



Set the *Timer* .

As soon as the time has run down, there is a sound signal but the appliance does not switch off.

Program end: Switch off and leave the door slightly open. **Close water tap**

If the appliance is re-started, the last settings are indicated on the display, memory .

5. Cleaning



Disconnect the unit from the mains.

Clean the appliance daily with a soft cloth or a sponge using normal cleaning agents.

Use a special decalcifying cleaner, for instance the deliming agent **eloma MULTI CLEAN** (Art. No. 522007, 522008) to remove calcareous deposits from stainless steel parts.



After cleaning, leave the door open for drying.

Do not use corrosive or scouring cleaners for the touch panel.

Clean glass panes only with a soft cloth. Do not use any scouring agents.



The appliance must not be cleaned with a water jet or high pressure sprayer.

6. Trouble shooting

If the appliance does not work properly, try to remedy the failure with the aid of the table below.

Failure	Possible reason	Remedy
LED in the ON/OFF touch is not lit, the unit cannot be started.	The power supply is not plugged	Plug it.
	Fuse switched off	Switch it on.
 LED- is lit, sound signal. Water shortage is announced.	There is no water in the tank, water tap is closed	Open water tap, fill by pressing touch water tank until the LED is out.



In case you cannot remedy the failure, switch the appliance off, disconnect it from the mains, close the water tap and **call the after-sales service !**

7. Data of the appliance

Model _____

Serial number _____

8. Service Notes

Date	After-sales service	Remarks

bdees120/160 10/97

9. Warranty Conditions

1. New *eloma* catering appliances

The *eloma GmbH* grants a twelve months regular warranty to endusers of new *eloma* appliances starting from the date of their dealers' invoice, however a maximum of eighteen months starting from the date of dispatch from the *eloma* factory in Maisach/Germany.

EXCEPTION: Damages to all glass parts and lighting glassware

Range of Warranty:

Within the warranty period, warranty is limited to the replacement of parts and/or repair of those at *eloma's* choice, in case their usability is considerably vitiated due to material defects, incorrect design or imperfect construction. An *eloma*-trained service technician in situ contributes to an adequate decision. The final decision is to be made by the *after-sales-service department* of *eloma* in Maisach/Germany or its representative.

In case of recognised warranty, *eloma* bears the costs for spare parts, as well as labour and travel expenses of the service technician. If possible the repair work is done at the place of the machine's installation. In case the appliance has to be returned to the *eloma* factory in Maisach, for whatever reason, transportation expenses back and forth are always at the customer's account. The customer also bears transportation risk.

eloma reserves the right to entrust certain persons with the execution of warranty repair work.

Warranty compensation

In case the sales object is sold to a purchaser outside the Federal Republic of Germany, or in case the sales object is used outside the FRG, a warranty compensation is applicable, it is already included in the granted sales discount. In the Federal Republic of Germany such warranty compensation may be agreed upon.

Warranty compensation signifies that *eloma* supplies the spare part but that secondary costs such as labour and travel expenses of the technician are not borne by *eloma*.

This Warranty excludes:

- Normal wear and tear
- Incorrect installation, not in accordance with our installation- and operation-manuals, local regulations and - general technical rules.
- Damages resulting from use of violence and/or malicious or incorrect handling and operation
- Damages due to calcareous deposits or aggressive water
- Damages resulting from use of cleaning agents not recommended by *eloma* or incorrect use of the proper cleaning agents
- Technical intervention of any kind into *eloma* appliances by staff not authorized and/or properly trained by *eloma*.

2. Parts Warranty

The *eloma GmbH* grants for each original *eloma* spare part, provided it is correctly installed, an operation warranty of six months. In case of failure within this period, *eloma* supplies another original part.. Further claims, also costs for such a replacement are not accepted. This warranty excludes parts which are subject to more-than-average wear and tear caused by the enduser.

3. General

Claims exceeding the stipulated elimination of defects, including consequential damages, loss of wages or property damages of whatever kind cannot be accepted. Claims for redhibition and depreciation can only be made if a warranty repair is proved to be a failure. Verbal promises assuring certain characteristics are only binding upon written confirmation.

eloma appliances shall only be used for their intended purpose namely the professional preparation of food. Whatever exception to this rule excludes all warranty claims and discharges *eloma* from all liability.

The warranty period is not renewed or extended in case of any repair or replacement delivery. *eloma* shall regain possession and control of such replaced parts and appliances.

This warranty is not transferable without *eloma's* written consent.

Place of jurisdiction is the location of *eloma's* registered office.

Technical amendments, also in the sense of further development and/or technical progress are reserved.

Maisach, March 1997

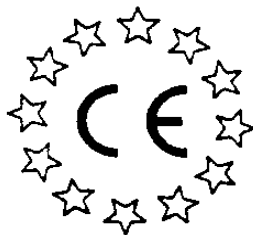

Declaration of Conformity

for Provers

EGS 120 , EGS 18

**eloma GmbH Großküchentechnik
Otto-Hahn-Str. 10
82216 Maisach**

declares as solely responsible manufacturer that the above mentioned Provers meet the requirements of the EEC Directive 89 / 336
In case of modifications without prior approval of our company, the present declaration shall no longer be valid.

eloma GmbH provides the following technical documents for examination:

Development sheets, design plans, drawings and operating instructions that meet the recognised rules for the elaboration of user information.

The conformity of the above mentioned Provers is guaranteed.

eloma GmbH

82216 Maisach, den 18.01.1996

The Management

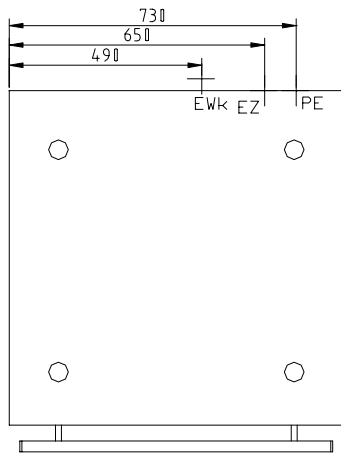
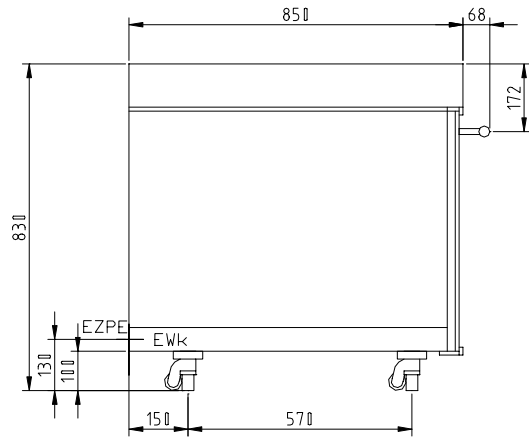
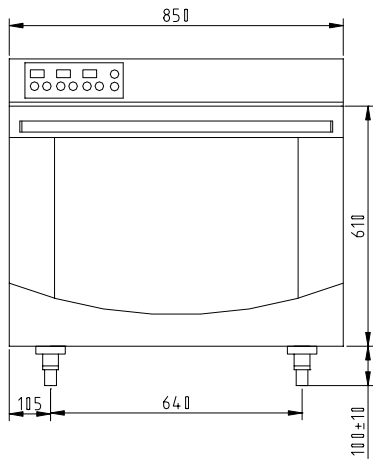

EWk Softet water cold G3/4A
 EZ Current
 PE Potential equalisation

Technical amendments reserved

Gärschrank	ES 120
eloma	915093
Maßskizze	01.02.05 wo/le

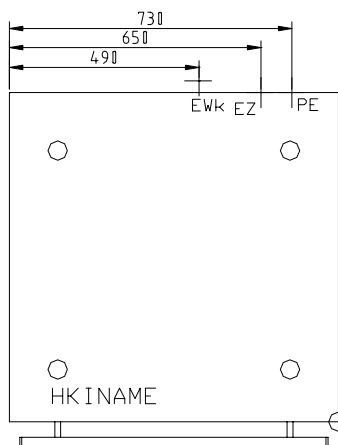
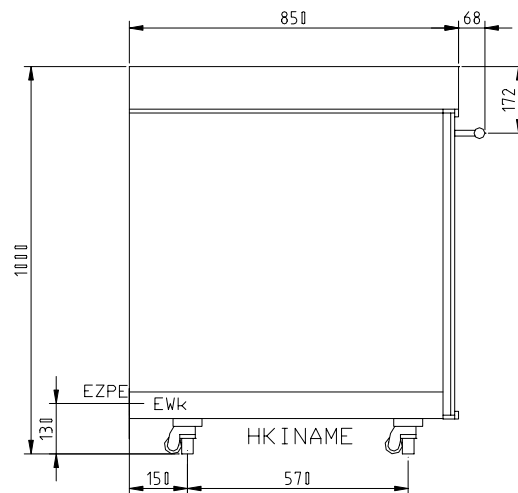
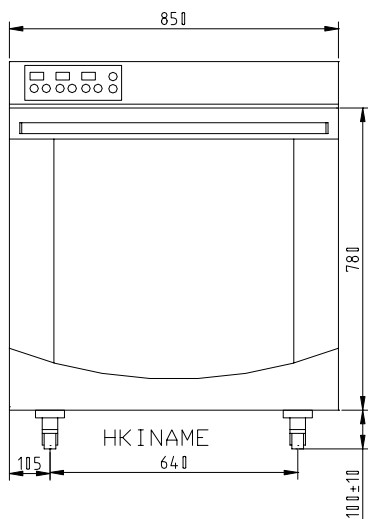

EWk Softet water cold G3/4A
 EZ Current
 PE Potential equalisation

Technical amendments reserved

Gärschrank	ES 160
eloma	915094
Maßskizze	01.02.05 wo/le

The logo for Eloma GmbH, featuring the word "eloma" in a bold, lowercase, sans-serif font. The text is white and is contained within a dark red rectangular box. A thin black line extends from the left side of the box, forming a step-like shape that goes up and then left.

Eloma GmbH
Otto-Hahn-Straße 10
82212 Maisach
Germany

Phone: +49 (0) 8141 395-0
Fax: +49 (0) 8141 395-130
www.eloma.com
info@eloma.com