

**Lavavasos
Lave-verres
Glass-washer
Glaspülmaschinen
Lavabicchieri
Lavacopos**

Modelos:

**AD-15
AD-21
AD-15 D
AD-21 B
AD-21 D
AD-21 W
AD-21 DD
AD-21 B DD**

Diciembre 2009 December

Revisado Julio 2013 July Revised



F A G O R I N D U S T R I A L

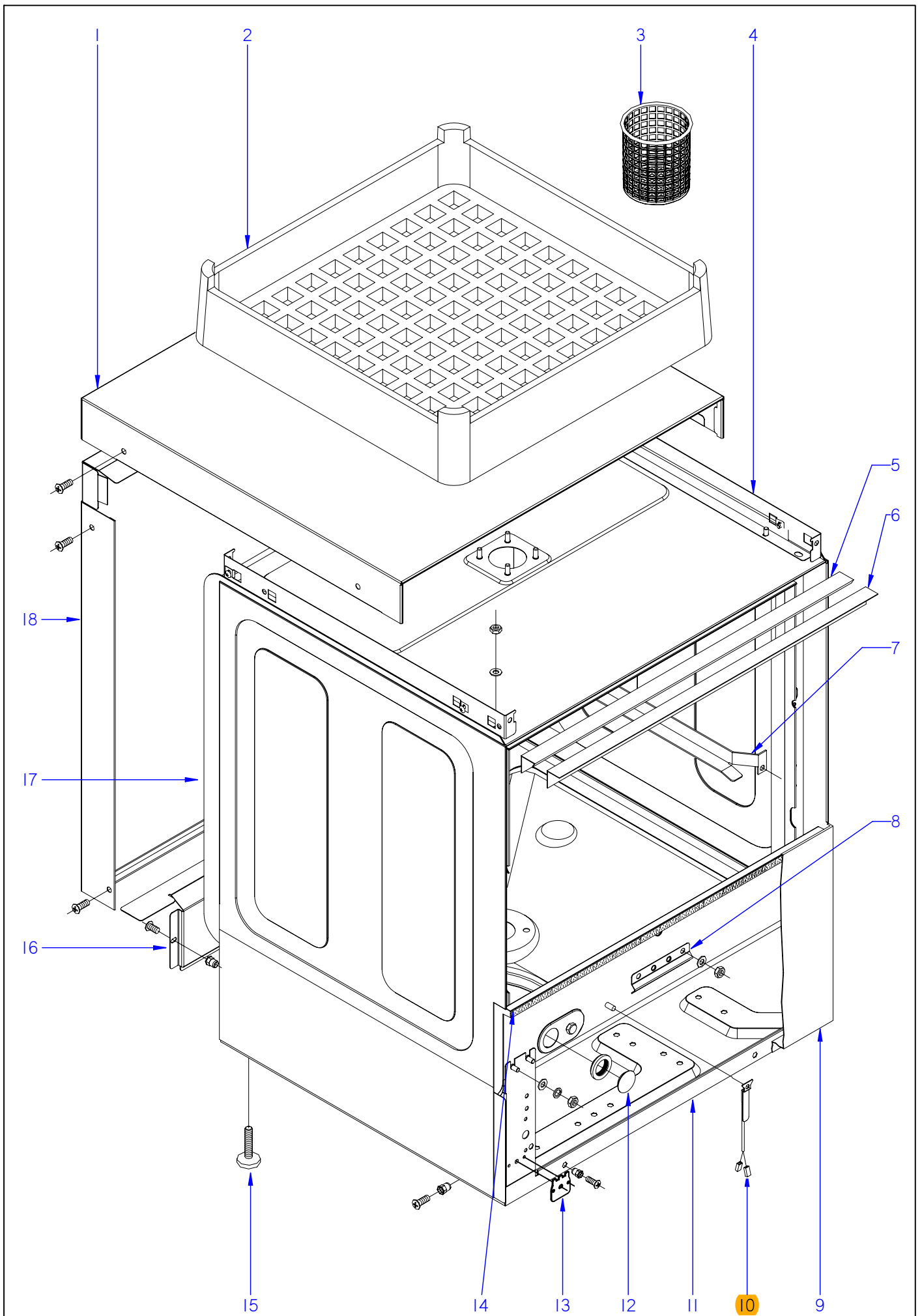

ITEM MARCADO EN COLOR = REPUESTO RECOMENDADO
 COLOURED ITEM = RECOMMENDED SPARE PART

N plano	Firma	Fecha	Aparato	MUEBLE	Lamina	Fagor Industrial S.Coop. FAGOR
C-2452	<i>(Signature)</i>	2009-12	LAVAVASOS AD		1	Oñate

MOD.		LAVAVASOS		ZONA	MUEBLE / UNIT						PLANO	C-2452
ITEM	CODIGO	DENOMINACION	TEXTO	AD-15	AD-15 D	AD-21	AD-21 B	AD-21 B DD	AD-21 D	AD-21 DD		NOTAS
1	Z412907000	TAPA AD-15	COVER AD-15	1	1							
1	Z442908000	TAPA AD-21	COVER AD-21			1	1	1	1	1		
1	Z442912000	TAPA AD-21C	COVER AD-21C									
	Q152004000	TORNILLO APLASTADO M5x13 A304	FLAT HEADED BOLT M5x13 A304	8	8	8	8	8	8	8		
2	Z415320000	CESTILLO LVC-12/15	BASKET LVC-12/15	2	2							
2	Z445320000	CESTILLO LVC-21	BASKET LVC-21			2	2	2	2	2		
3	Z605303000	CESTILLO CUBIERTOS	CUTLERY BASKET	1	1	1	1	1	1	1		
S/Nº	Z605302000	SUPLEMENT. CESTILLOS LAVA.-12	SUPPLEMENT. WASH BASKET.-1	1	1							
S/N	Z625302000	SUPLEMENT. PLATILLOS LAVAV.18	SUPPLEMENT. GLASS WASHER			1	1	1	1	1		
4	Z410309000	ESCUADRA AMARRE TAPA 12-15	FASTENING BRACKET COVER TA	2	2							ELIMINADO 26.03.10
4	Z410317000	ESCUADRA AMARRE TAPA 12-15	FASTENING BRACKET COVER TA	2	2							INTRODUC. 26.03.10
4	Z420318000	ESCUADRA AMARRE TAPA 21	COVER FASTENING BRACKET 21			2	2	2	2	2		ELIMINADO 29.01.10
4	Z420319000	ESCUADRA AMARRE TAPA 21	COVER FASTENING BRACKET 21			2	2	2	2	2		INTRODUC. 29.01.10
	Q162040000	TUERCA EXAGONAL M6	HEXAGONAL NUT M6	4	4	4	4	4	4	4		
	Q221012000	TUERCA RAPIDA M,5	RAPID NUT M,5	6	6	6	6	6	6	6		
5	Z400315000	PERFIL CAJA	BOX PROFILE	1	1							
5	Z420315000	PERFIL CAJA	BOX PROFILE			1	1	1	1	1		
6	Z400306000	ESCUADRA SUJECCION PERFIL	FASTENING BRACKET PROFILE	1	1							
6	Z420306000	ESCUADRA SUJECCION PERFIL	FASTENING BRACKET PROFILE			1	1	1	1	1		
	Q262040000	ARANDELA GROW. A6 A.304	WASHER GROW. A6 A.304	2	2	2	2	2	2	2		
	Q162040000	TUERCA EXAGONAL M6	HEXAGONAL NUT M6	2	2	2	2	2	2	2		
7	Z410304000	GUIA CESTILLO DERECHA C12-15	RIGHT BASKET GUIDE C12-15	1	1							
7	Z440304000	GUIA CESTILLO DERECHA	RIGHT BASKET GUIDE			1	1	1	1	1		
S/Nº	Z410303000	GUIA CESTILLO IZQUIERDA C12-15	LEFT BASKET GUIDE C12-15	1	1							
S/Nº	Z440303000	GUIA CESTILLO IZQUIERDA	LEFT BASKET GUIDE			1	1	1	1	1		
	Q162040000	TUERCA EXAGONAL M6	HEXAGONAL NUT M6	4	4	4	4	4	4	4		
8	Z748008000	SOPORTE BULBO TERMOSTATO	THERMOSTAT BULB SUPPORT					1				ELIMINADO 19.10.11
	Q162040000	TUERCA EXAGONAL M6	HEXAGONAL NUT M6					1				ELIMINADO 19.10.11
	Q262040000	ARANDELA GROW. A6 A.304	WASHER GROW. A6 A.304					1				ELIMINADO 19.10.11

MOD.		LAVAVASOS		ZONA	MUEBLE / UNIT						PLANO	C-2452
ITEM	CODIGO	DENOMINACION	TEXTO	AD-15	AD-15 D	AD-21	AD-21 B	AD-21 B DD	AD-21 D	AD-21 DD		NOTAS
9	Z468611000	PANEL FRONTAL10-12-14-15 NEU	FRONT PANEL10-12-14-15 NEU	1	1							
9	Z448611000	PANEL FRONTAL C21	FRONT PANEL C21			1			1	1		
9	Z458611000	PANEL FRONTAL 21B	FRONT PANEL 21B				1	1				
10	Z713028000	SONDA TEMPERATURA GICAR	TEMPERATURA PROBE GICAR	1	1	1	1	1	1	1		
S/Nº	Z718004000	AMARRE SONDA	PROBE CATCH	1	1	1	1	1	1	1		ELIMINADO 24.09.12
S/Nº	Z718004000	AMARRE SONDA	PROBE CATCH	2	2	2	2	2	2	2		INTRODUC. 24.09.12
	Q162020000	TUERCA EXAGONAL M4	HEXAGONAL NUT M4	1	1	1	1	1	1	1		
11	Z468720000	ARMAZON COMPLETO	COMPLETE FRAME	1	1							ELIMINAD. 06.10.12
11	12046711	ARMAZON COMPLETO LVC-12	COMPLETE FRAME LVC-12	1	1							INTRODUC.06.10.12
11	Z420101000	ARMAZON COMPLETO	COMPLETE FRAME			1	1	1	1	1		ELIMINAD. 06.10.12
11	12046707	ARMAZON COMPLETO LVC-21	COMPLETE FRAME LVC-21			1	1	1	1	1		INTRODUC.06.10.12
12	P443060000	TAPON	STOPPER	1	1	1	1	1	1	1		
S/Nº	N503017000	SOPORTE TERMOSTATO 1001713	THERMOSTAT SUPPORT 1001713	1	1	1	1	1	1	1		
13	Z713038000	REGU. TERMOS. TANQUE 60 °C	THERM.TANQUE REGULATOR	1	1	1	1	1	1	1		ELIMINADO 30.11.12
13	12044848	REGULADOR A 60°C Tc DE 85°C	REGULATOR 60°C Tc DE 85°C	1	1	1	1	1	1	1		ELIMINADO 03.12.12
13	12022008	REGU. TERMOS. TANQUE 60 °C	THERM.TANQUE REGULATOR	1	1	1	1	1	1	1		INTRODUC. 03.12.12
14	Z400309000	PERFIL INFERIOR CAJA	BOX LOWER PROFILE	1	1							
14	Z420309000	PERFIL INFERIOR CAJA	BOX LOWER PROFILE			1	1	1	1	1		
15	Z200107000	PATA REGULABLE	ADJUSTABLE LEG	4	4	4	4	4	4	4		
16	Z402908000	PANEL POSTERIOR INFERIO. 1-4-2-5	LOWER REAR PANEL. 1-4-2-5	1	1							
16	Z422908000	PANEL POSTERIOR INFERIOR 20-21	LOWER REAR PANEL 20-21			1	1	1	1	1		
17	Z468730000	CAJA SOLDADA	WELDED BOX	1								
17	Z480311000	CAJA SOLDADA LVC-15D	WELDED BOX LVC-15D		1							
17	Z440313000	CAJA SOLDADA AD-21	WELDED BOX ADC-21			1						
17	Z440313000	CAJA SOLDADA AD-21	WELDED BOX ADC-21				1	1		1		ELIMINAD.19.02.10
17	Z450301000	CAJA SOLDADA AD-21 B, DD,C	WELDED BOX AD-21 B, DD,C				1	1		1		INTRODUC.19.02.10
17	Z500311000	CAJA SOLDADA LVC-21D	WELDED BOX LVC-21D						1			
	Q162040000	TUERCA EXAGONAL M6	HEXAGONAL NUT M6	8	8	8	8	8	8	8		
	Q262040000	ARANDELA GROW. A6 A.304	WASHER GROW. A6 A.304	8	8	8	8	8	8	8		
18	Z402902000	PANEL POSTERIOR A R-10 C-12	REAR PANEL A R-10 C-12	1	1							
18	Z422902000	PANEL POSTERIOR R20-C21	REAR PANEL R20-C21			1	1	1	1	1		

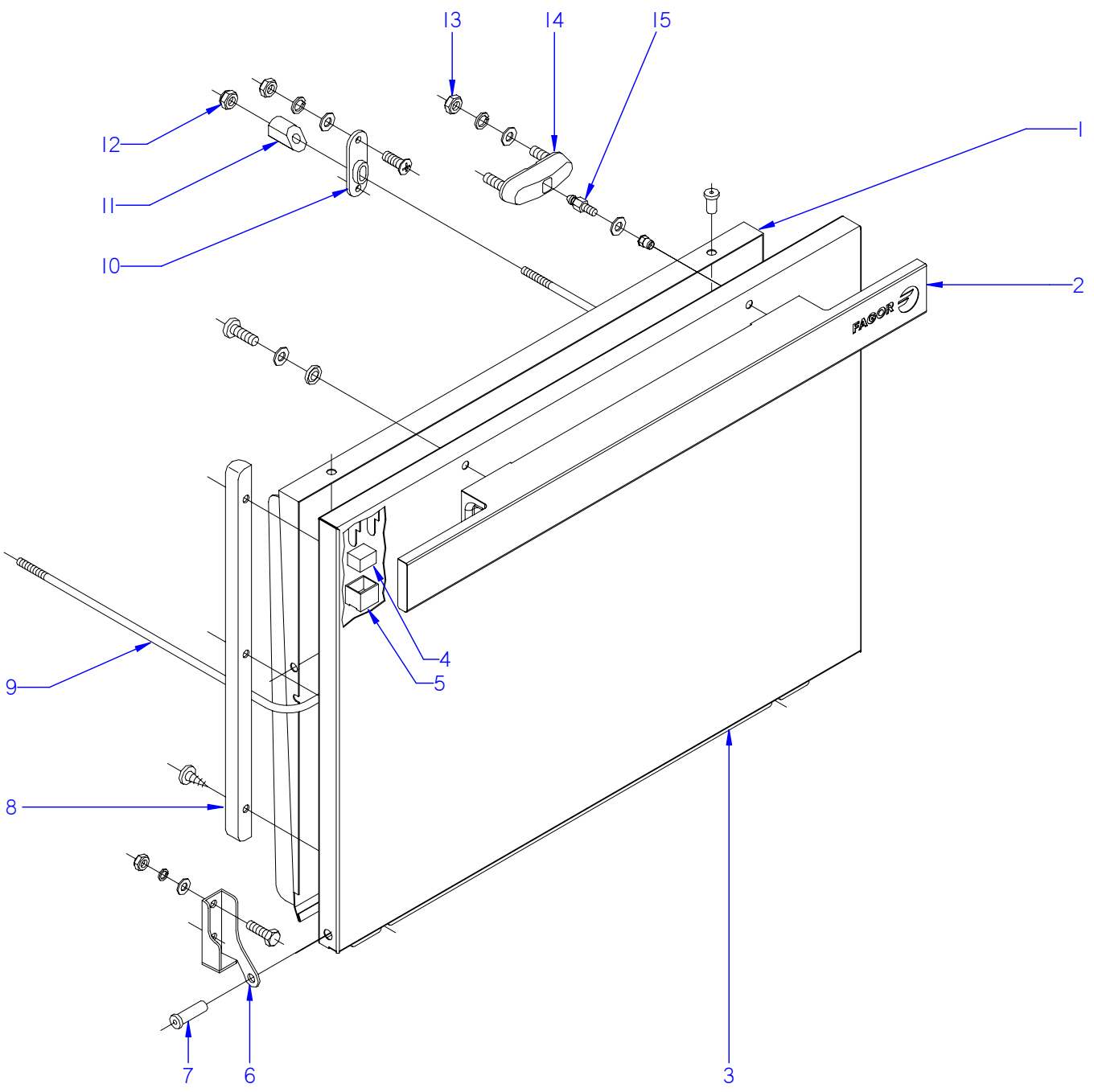

ITEM MARCADO EN COLOR = REPUESTO RECOMENDADO
 COLOURED ITEM = RECOMMENDED SPARE PART

N plano C-2453	Firma <i>[Signature]</i>	Fecha 2009-12	Aparato LAVAVASOS AD	Lamina 2	Fagor Industrial S. Coop. Omate
PUERTA					



MOD.		LAVAVASOS		ZONA	PUERTA / DOOR						PLANO	C-2453
ITEM	CODIGO	DENOMINACION	TEXTO	AD-15	AD-15 D	AD-21	AD-21 B	AD-21 B DD	AD-21 D	AD-21 DD		NOTAS
	12092605	KIT PUERTA AD-21	DOOR KIT AD-21			1	1	1	1	1		
1	Z400511000	CONTRAPUERTA COMPLETA	COMPL. DOOR REVERSE	1	1							
1	Z420513000	CONTRAPUERTA COMPL. R20-C21	COMPL. DOOR REVERSE R20-C21			1	1	1	1	1		
	Q412000000	REMACHE TUBULAR 4 x 8	TUBULAR RIVET 4 x 8	4	4	4	4	4	4	4		
2	Z460501000	ASA AD-12	HANDLE AD-12	1	1							ELIMINADO 31.03.10
2	Z460503000	ASA AD-15	HANDLE AD-15	1	1							INTRODUC. 31.03.10
2	Z440501000	ASA AD-21	HANDLE AD-21			1	1	1	1	1		ELIMINADO 31.03.10
2	Z440505000	ASA AD-21	HANDLE AD-21			1	1	1	1	1		INTRODUC. 31.03.10
S/Nº	Z200564000	TACO SUJECCION	FASTENING RAWL	2	2	2	2	2	2	2		ELIMINADO 15.02.11
S/Nº	Z210503000	TACO SUJECCION	FASTENING RAWL	2	2	2	2	2	2	2		INTRODUC. 15.02.11
	Q012045000	TORNILLO EXAGONAL M6X30	HEXAGONAL BOLT M6x30	2	2	2	2	2	2	2		
	Q262040000	ARANDELAGROW. A6 A.304	WASHER GROW. A6 A.304	2	2	2	2	2	2	2		
3	Z410502000	PUERTA COMPLETA AD-15	COMPLETE DOOR AD-15	1	1							
3	Z440504000	PUERTA COMPLETA AD-21	COMPLETE DOOR AD-21			1	1	1	1	1		
S/Nº	Z206135000	CHECK LIST LAVAVAJILLAS FAGOR	CHECK LIST	1	1	1	1	1	1	1		INTRODUC. 19.07.10
4	Z200506000	IMAN	MAGNET	1	1	1	1	1	1	1		
5	Z200507000	PROTECTOR IMAN	MAGNET PROTECTOR	1	1	1	1	1	1	1		
6	Z400514000	BISAGRA IZQUIERDA T-C.	LEFT HINGE T-C.	1	1	1	1	1	1	1		
S/Nº	Z400515000	BISAGRA DERECHA T-C.	RIGHT HINGE T-C.	1	1	1	1	1	1	1		
	Q012042000	TORNILLO EXAGONAL M6X15	HEXAGONAL BOLT M6x15	4	4	4	4	4	4	4		
	Q232040000	ARANDELA A6	WASHER A6	4	4	4	4	4	4	4		
	Q262040000	ARANDELAGROW. A6 A.304	WASHER GROW. A6 A.304	4	4	4	4	4	4	4		
	Q162040000	TUERCA EXAGONAL M6	HEXAGONAL NUT M6	4	4	4	4	4	4	4		
7	Z400516000	EJE PUERTA	DOOR SHAFT	2	2	2	2	2	2	2		
8	Z400522000	GUIA IZQUIERDA	LEFT GUIDE	1	1							
8	Z420522000	GUIA IZQUIERDA	LEFT GUIDE			1	1	1	1	1		
S/Nº	Z400521000	GUIA DERECHA	RIGHT GUIDE	1	1							
S/Nº	Z420521000	GUIA DERECHA	RIGHT GUIDE			1	1	1	1	1		
	Q412000000	REMACHE TUBULAR 4 x 8	TUBULAR RIVET 4 x 8	4	4	4	4	4	4	4		
9	Z420519000	VARILLA TENSOR	TIGHTENER ROD			1	1	1	1	1		

MOD.		LAVAVASOS		ZONA		PUERTA / DOOR					PLANO		C-2453	
ITEM	CODIGO	DENOMINACION	TEXTO	AD-15	AD-15 D	AD-21	AD-21 B	AD-21 B DD	AD-21 D	AD-21 DD		NOTAS		
10	Z200310000	SOPORTE TENSOR	TIGHTENER SUPPOR			2	2	2	2	2				
11	Z200522000	TENSOR PUERTA	TIGHTENER DOOR			2	2	2	2	2				
12	Q222012000	TUERCA AUTOB. M6	SELF-LOCKING NUT M6			2	2	2	2	2				
13	Q222012000	TUERCA AUTOB. M6	SELF-LOCKING NUT M6	2	2	2	2	2	2	2				
14	Z200607000	CONJUNTO CIERRE PUER.T-CO	LOCK UNIT PUERTAT-CO	1	1	1	1	1	1	1				
15	Z200601000	ENGANCHE CIERRE	LOCK LATCH	1	1	1	1	1	1	1				
	Q232030000	ARANDELA A5	WASHER A5	1	1	1	1	1	1	1				

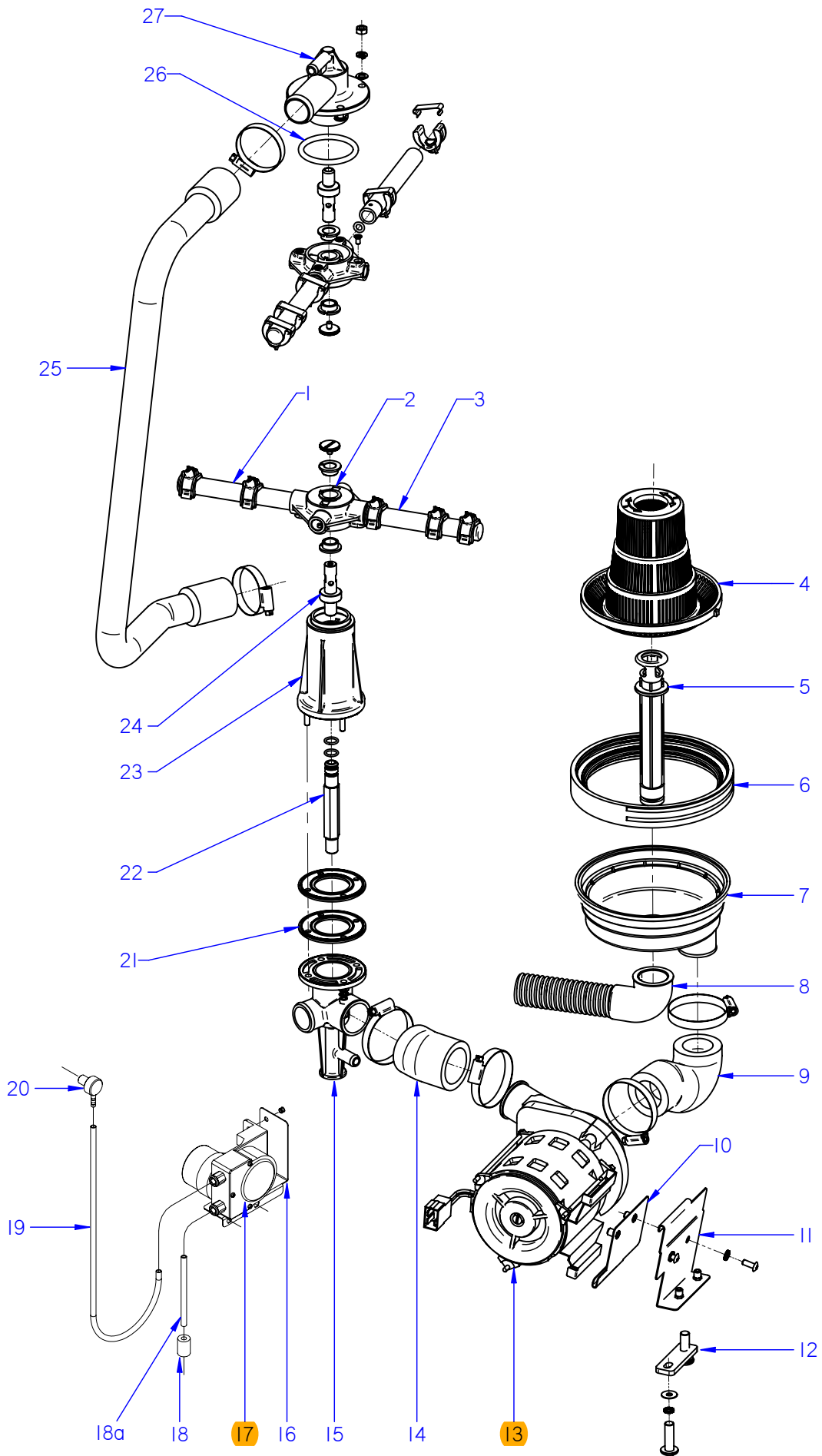

ITEM MARCADO EN COLOR = REPUESTO RECOMENDADO
 COLOURED ITEM = RECOMMENDED SPARE PART

N plano	Firma	Fecha	Aparato	CONJUNTO FUNCIONAL LAVADO	Lamina	Fagor Industrial S.Coop. FAGOR
C-2454	<i>[Signature]</i>	2009-12	LAVAVAS. AD-15; 15D; 21; 21D; 21DD		3	Oñate

MOD.		LAVAVASOS		ZONA	CONJUNTO FUNCIONAL LAVADO					PLANO	C-2454
ITEM	CODIGO	DENOMINACION	TEXTO	AD-15	AD-15 D	AD-21	AD-21 D	AD-21 DD			NOTAS
1	Z460701000	RAMA LAVADO B	WASH B BRANCH	2	2						
1	Z440707000	RAMA LAVADO B	WASH B BRANCH			2	2	2			
	Z400709000	TOBERA LAVADO	WASH NOZZLE	5	5	6	6	6			
	Z400711000	ENGANCHE TOBERA LAVADO	WASH NOZZLE CATCH	5	5	6	6	6			
2	Z410704000	CRUCETA	CROSSPIECE	2	2	2	2	2			
	Q152016000	TORNILLO ESPECIAL M.5X0.8	SPECIAL BOLT M.5X0.8	2	2	2	2	2			
	Z410705000	CASQUILLO CRUCETA	CROSSPIECE BUSHING	4	4	4	4	4			
3	Z460702000	RAMA LAVADO A	WASH BRANCH A	2	2						
3	Z440706000	RAMA LAVADO A	WASH BRANCH A			2	2	2			
	Z400709000	TOBERA LAVADO	WASH NOZZLE	5	5	6	6	6			
	Z400711000	ENGANCHE TOBERA LAVADO	WASH NOZZLE CATCH	5	5	6	6	6			
4	Z400920000	FILTRO ALTO	HIGH FILTER	1	1	1	1	1			
5	Z400907000	ALIVIADERO	OVERFLOW	1	1	1	1	1			
S/Nº	12010282	JUNTA TORICA 25.4X20.2X2.6	O-RING 25.4X20.2X2.6	1	1	1	1	1			
6	Z400902000	JUNTA CUBETA	TRAY SEAL	1	1	1	1	1			
7	Z400901000	CUBETA	TRAY	1	1	1	1	1			
	Z400903000	ABRAZADERA CUBETA	TRAY CLAMP	1	1	1	1	1			
8	Z400908000	MANGUERA DESAGÜE	DRAINAGE HOSE	1	1	1	1	1			
	Q901307000	ABRAZADERA ELASTICA 37.7-39.7	ELASTIC CLAMP 37.7-39.7	1	1	1	1	1			
9	Z400905000	CODO ASPIRACION 1003115	EXTRACTOR ELBOW 1003115	1	1	1	1	1			
	Q881307000	ABRAZADERA 40-60	CLAMP 40-60	2	2	2	2	2			
10	Z401004000	AMARRE MOTOBOMBA	MOTORPUMP FASTENING	1	1	1	1	1			
11	Z401002000	SOPORTE MOTOBOMBA	MOTOR PUMP SUPPORT	1	1						
11	Z421002000	SOPORTE MOTOBOMBA	MOTOR PUMP SUPPORT			1	1	1			
	Q152004000	TORNILLO APLASTADO M5x13 A304	FLAT HEADED BOLT M5x13 A304	2	2	2	2	2			
	Q242030000	ARANDELA ABANICO A5 A.304	FAN WASHER A5 A.304	2	2	2	2	2			
12	Z401006000	PERFIL AMORTIGUADOR	SHOCK ABSORBER PROFILE	1	1	1	1	1			
	Q302022000	ARANDELA 16x6x1,2 A304	WASHER 16x6x1.2 A304	2	2	2	2	2			
	Q032032000	TORNILLO ALOMADO M5X15	CURVED SCREW M5X15	2	2	2	2	2			
13	Z401001000	BOMBA LAVADO	WASH PUMP	1	1	1	1	1			
	Z401001100	TURBINA BOMBA Z401001	TURBINE PUMP Z401001	1	1	1	1	1			

MOD.		LAVAVASOS		ZONA	CONJUNTO FUNCIONAL LAVADO					PLANO	C-2454
ITEM	CODIGO	DENOMINACION	TEXTO	AD-15	AD-15 D	AD-21	AD-21 D	AD-21 DD			NOTAS
14	Z400906000	CODO IMPULSION 1003116	IMPULSE ELBOW 1003116	1	1	1	1	1			
	Q881307000	ABRAZADERA 40-60	CLAMP 40-60	2	2	2	2	2			
15	Z410702000	PASAMUROS CESTO CUADRADO	SQUARE BASKET WALL BUSHING	1	1	1	1	1			
	Q232030000	ARANDELA A5	WASHER A5	4	4	4	4	4			
	Q262030000	ARANDELA GROW. A5 A.304	WASHER GROW. A5 A.304	4	4	4	4	4			
	Q162030000	TUERCA EXAGONAL M5	HEXAGONAL NUT M5	4	4	4	4	4			
16	Z208909000	SOPORTE DOSIF. DETERGENTE	DETERGENT DISP. SUPPORT	-	-	-	-	1			
	Q419005000	REMACHE 4X8 ALMG3 / ALUMINIO	RIVET 4X8 ALMG3 / ALUMINIUM	-	-	-	-	2			
17	Z208903000	DOSIFIC. DGTE REGULABLE G300	DETERGENT DISP. ADJUST. G300	-	-	-	-	1			
	Q012031000	TORNIL. EXAGONAL M5X10 A.304	HEX BOLT M5X10 A.304	-	-	-	-	2			
	Q232030000	ARANDELA A5	WASHER A5	-	-	-	-	2			
18	Z701152000	PESO FILTRO	FILTER WEIGHT	-	-	-	-	1			
18a	Z448614000	CONDUCTO ASPIRACIÓN	EXTRACTOR PIPE	-	-	-	-	1			
19	3699300000	CONDUCTO DOSIF. TRANSPARENTE	TRANSPAR. EXTRACTOR PIPE	-	-	-	-	1			
20	Z230905000	PASAMUROS INOX DETERGENTE	INOX DETERGENT WALL BUSHING	-	-	-	-	1			ELIMINADO 30.11.10
20	Z208927000	PASAMUROS INOX DETERGENTE	INOX DETERGENT WALL BUSHING	-	-	-	-	1			INTRODUCIDO 30.11.10
21	Z400703000	JUNTA ESTANQUE. 1003113	SEAL. 1003113	2	2	2	2	2			
22	Z410712000	EMPALME ACLARADO	RINSE CONNECTION	1	1	1	1	1			
	Q307056000	JUNTA TORICA 10,82x14,38x1,78	O-RING 10.82x14.38x1.78	2	2	2	2	2			
23	Z410701000	SOPORTE INFERIOR CUADRO	LOWER SUPPORT BRACKET	1	1	1	1	1			
24	Z410708000	EJE	SHAFT	2	2	2	2	2			
25	Z410711000	ARBOL LAVADO	WASH CAM	1	1	-	-	-			
25	Z440711000	ARBOL LAVADO	WASH CAM	-	-	1	1	1			
	Q881306000	ABRAZADERA 32-50L	CLAMP 32-50L	2	2	2	2	2			
26	Q307052000	JUNTA TORICA 50,17X60,83X5,3	O-RING 50.17X60.83X5.3	1	1	1	1	1			
27	Z410703000	SOPORTE DISTRIB. SUPERIOR	UPPER DISTRIB. SUPPORT	1	1	1	1	1			
	Q232040000	ARANDELA A6	WASHER A6	4	4	4	4	4			
	Q262040000	ARANDELA GROW. A6 A.304	WASHER GROW. A6 A.304	4	4	4	4	4			
	Q162040000	TUERCA EXAGONAL M6	HEXAGONAL NUT M6	4	4	4	4	4			

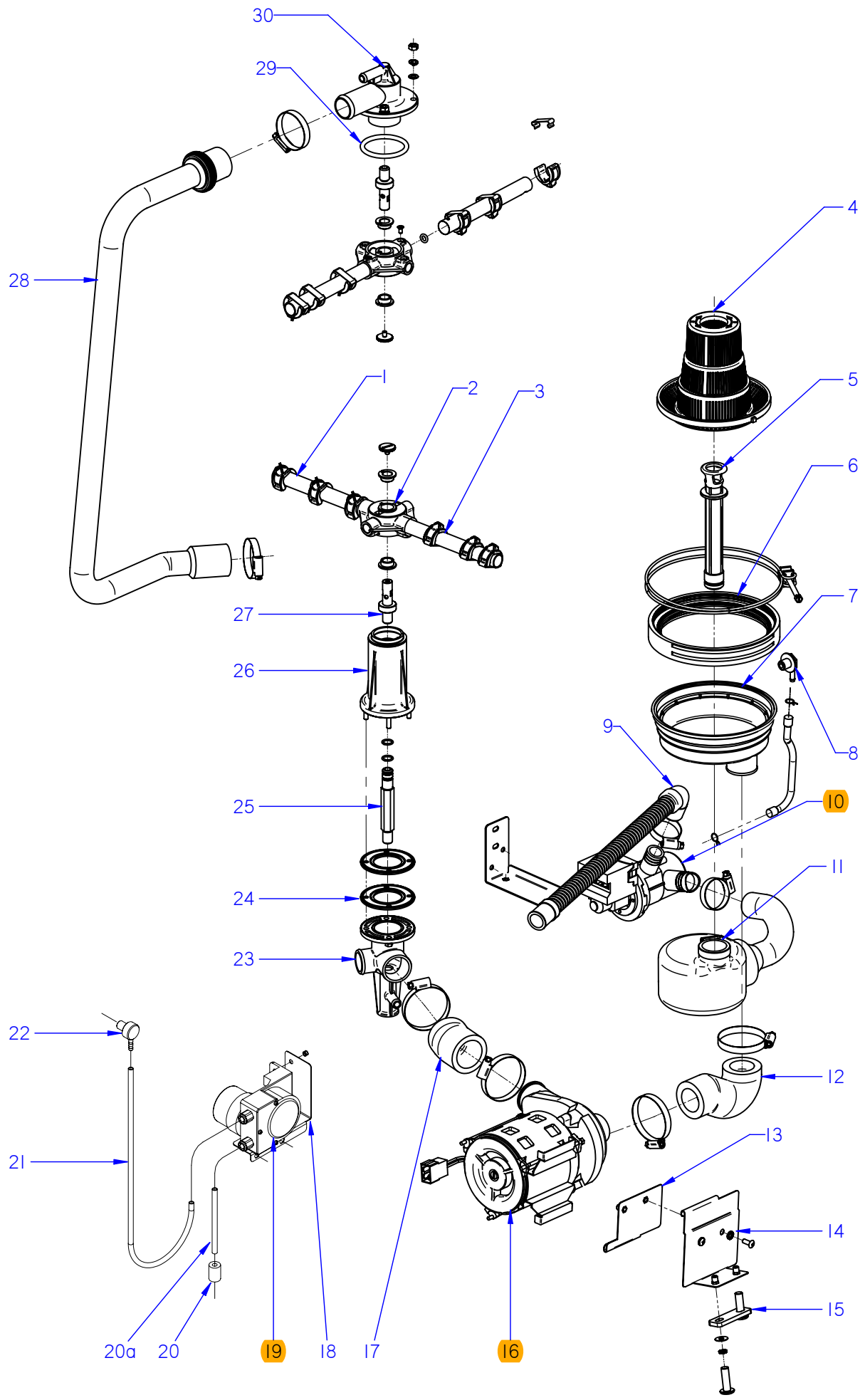

ITEM MARCADO EN COLOR = REPUESTO RECOMENDADO
 COLOURED ITEM = RECOMMENDED SPARE PART

N plano	Firma	Fecha	Aparato	CONJUNTO FUNCIONAL LAVADO	Lamina	Fagor Industrial S.Coop. FAGOR
C-2455	<i>[Signature]</i>	2009-12	LAVAVAS. AD-21B ; AD-21B DD		4	Oñate

MOD.		LAVAVASOS		ZONA	CONJUNTO FUNCIONAL LAVADO				PLANO	C-2455
ITEM	CODIGO	DENOMINACION	TEXTO	AD-21 B	AD-21 B DD					NOTAS
1	Z440707000	RAMA LAVADO B	WASH B BRANCH	2	2					
S/Nº	Z400709000	TOBERA LAVADO	WASH NOZZLE	12	12					
S/Nº	Z400711000	ENGANCHE TOBERA LAVADO	WASH NOZZLE CATCH	12	12					
2	Z410704000	CRUCETA	CROSSPIECE	2	2					
	Q152016000	TORNILLO ESPECIAL M.5X0.8	SPECIAL BOLT M.5X0.8	2	2					
	Z410705000	CASQUILLO CRUCETA	CROSSPIECE BUSHING	4	4					
3	Z440706000	RAMA LAVADO A	WASH BRANCH A	2	2					
4	Z400920000	FILTRO ALTO	HIGH FILTER	1	1					
5	Z400907000	ALIVIADERO	OVERFLOW	1	1					ELIMINADO 24.06.2013
5	12047160	ALIVIADERO LVS MOD. B	OVERFLOW LVS MOD. B	1	1					INTRODUCIDO 24.06.2013
S/Nº	12010282	JUNTA TORICA 25.4X20.2X2.6	O-RING 25.4X20.2X2.6	1	1					
6	Z400902000	JUNTA CUBETA	TRAY SEAL	1	1					
7	Z400901000	CUBETA	TRAY	1	1					
	Z400903000	ABRAZADERA CUBETA	TRAY CLAMP	1	1					
8	Z230905000	PASAMUROS INOX DETERGENTE	INOX DETERGENT WALL BUSHIN	1	1					
	P102154000	BRIDA ELASTICA TUBO	ELASTIC PIPE FLANGE	2	2					
	3702400000	TUBO GOMA NEGRO D 8*4	BLACK RUBBER PIPE Ø 8*4	1	1					
9	Z220903000	MANGUERA DESAGÜE	DRAINAGE HOSE	1	1					
	Q901307000	ABRAZADERA ELASTICA 37.7-39.7	ELASTIC CLAMP 37.7-39.7	1	1					
10	Z220901000	BOMBA DESAGUE 30W	DRAINAGE PUMP 30W	1	1					
10	Z223501000	BOMBA DE DESAGUE 30W 60HZ	DRAINAGE PUMP 30W 60HZ	1	1					
	Z430902000	SOPORTE BOMBA DESAGUE B	DRAINAGE PUMP SUPPORT B	1	1					
	Q012031000	TORNILLO EXAGONAL M5X10	HEXAGONAL BOLT M5x10	2	2					
	Q242030000	ARANDELA ABANICO A5 A.304	FAN WASHER A5 A.304	2	2					
11	Z430901000	ACUMULADOR 1503114	ACCUMULATOR 1503114	1	1					
	Q901307000	ABRAZADERA ELASTICA 37.7-39.7	ELASTIC CLAMP 37.7-39.7	1	1					
12	Z400905000	CODO ASPIRACION 1003115	EXTRACTOR ELBOW 1003115	1	1					
	Q881307000	ABRAZADERA 40-60	CLAMP 40-60	2	2					
13	Z401004000	AMARRE MOTOBOMBA	MOTORPUMP FASTENING	1	1					
14	Z421002000	SOPORTE MOTOBOMBA	MOTOR PUMP SUPPORT	1	1					
	Q152004000	TORNILLO APLASTADO M5x13 A304	FLAT HEADED BOLT M5x13 A304	2	2					

MOD.		LAVAVASOS		ZONA	CONJUNTO FUNCIONAL LAVADO				PLANO	C-2455
ITEM	CODIGO	DENOMINACION	TEXTO	AD-21 B	AD-21 B DD					NOTAS
15	Z401006000	PERFIL AMORTIGUADOR	SHOCK ABSORBER PROFILE	1	1					
	Q242030000	ARANDELA ABANICO A5 A.304	FAN WASHER A5 A.304	2	2					
	Q302022000	ARANDELA 16x6x1,2 A304	WASHER 16x6x1.2 A304	2	2					
	Q032032000	TORNILLO ALOMADO M5X15	CURVED SCREW M5X15	2	2					
16	Z401001000	BOMBA LAVADO	WASH PUMP	1	1					
	Z401001100	TURBINA BOMBA Z401001	TURBINE PUMP Z401001	1	1					
17	Z400906000	CODO IMPULSION 1003116	IMPULSE ELBOW 1003116	1	1					
	Q881307000	ABRAZADERA 40-60	CLAMP 40-60	2	2					
18	Z208909000	SOPORTE DOSIF. DETERGENTE	DETERGENT DISP. SUPPORT	1	1					
	Q419005000	REMACHE 4X8 ALMG3 / ALUMINIO	RIVET 4X8 ALMG3 / ALUMINIUM	1	2					
19	Z208903000	DOSIFIC. DGTE REGULABLE G300	DETERGENT DISP. ADJUST. G300	1	1					
	Q012031000	TORNIL. EXAGONAL M5X10 A.304	HEX BOLT M5X10 A.304	1	2					
	Q232030000	ARANDELA A5	WASHER A5	1	2					
20	Z701152000	PESO FILTRO	FILTER WEIGHT	1	1					
20a	Z448614000	CONDUCTO ASPIRACIÓN	EXTRACTOR PIPE	1	1					
21	3699300000	CONDUCTO DOSIF. TRANSPARENT	TRANSPAR. EXTRACTOR PIPE	1	1					
22	Z230905000	PASAMUROS INOX DETERGENTE	INOX DETERGENT WALL BUSHING	1	1					ELIMINADO 30.11.10
22	Z208927000	PASAMUROS INOX DETERGENTE	INOX DETERGENT WALL BUSHING	1	1					INTRODUCIDO 30.11.10
S/Nº	Z208904000	CABLEADO DOSIFICADOR DTGTE.	DETERGENT DISP. WIRING	1	1					
23	Z410702000	PASAMUROS CESTO CUADRADO	SQUARE BASKET WALL BUSHING	1	1					
	Q232030000	ARANDELA A5	WASHER A5	4	4					
	Q262030000	ARANDELA GROW. A5 A.304	WASHER GROW. A5 A.304	4	4					
	Q162030000	TUERCA EXAGONAL M5	HEXAGONAL NUT M5	4	4					
24	Z400703000	JUNTA ESTANQUE. 1003113	SEAL. 1003113	2	2					
25	Z410712000	EMPALME ACLARADO	RINSE CONNECTION	1	1					
	Q307056000	JUNTA TORICA 10,82x14,38x1,78	O-RING 10.82x14.38x1.78	2	2					
26	Z410701000	SOPORTE INFERIOR CUADRO	LOWER SUPPORT BRACKET	1	1					
27	Z410708000	EJE	SHAFT	2	2					
28	Z440711000	ARBOL LAVADO	WASH CAM	1	1					
	Q881306000	ABRAZADERA 32-50L	CLAMP 32-50L	2	2					
29	Q307052000	JUNTA TORICA 50,17X60,83X5,3	O-RING 50.17X60.83X5.3	1	1					

ITEM	CODIGO	DENOMINACION	TEXTO	AD-21 B	AD-21 B DD						NOTAS
30	Z410703000	SOPORTE DISTRIB. SUPERIOR	UPPER DISTRIB. SUPPORT	1	1						
	Q232040000	ARANDELA A6	WASHER A6	4	4						
	Q262040000	ARANDELA GROW. A6 A.304	WASHER GROW. A6 A.304	4	4						
	Q162040000	TUERCA EXAGONAL M6	HEXAGONAL NUT M6	4	4						

N plano	Firma	Fecha	Aparato	Lamina	Fogor Industrial S. Coop.
C-2456	<i>(Firma)</i>	2009-12	LAVAVASOS AD-15	5	Omate
CONJUNTO FUNCIONAL ACLARADO					

ITEM MARCADO EN COLOR = REPUESTO RECOMENDADO
 COLOURED ITEM = RECOMMENDED SPARE PART

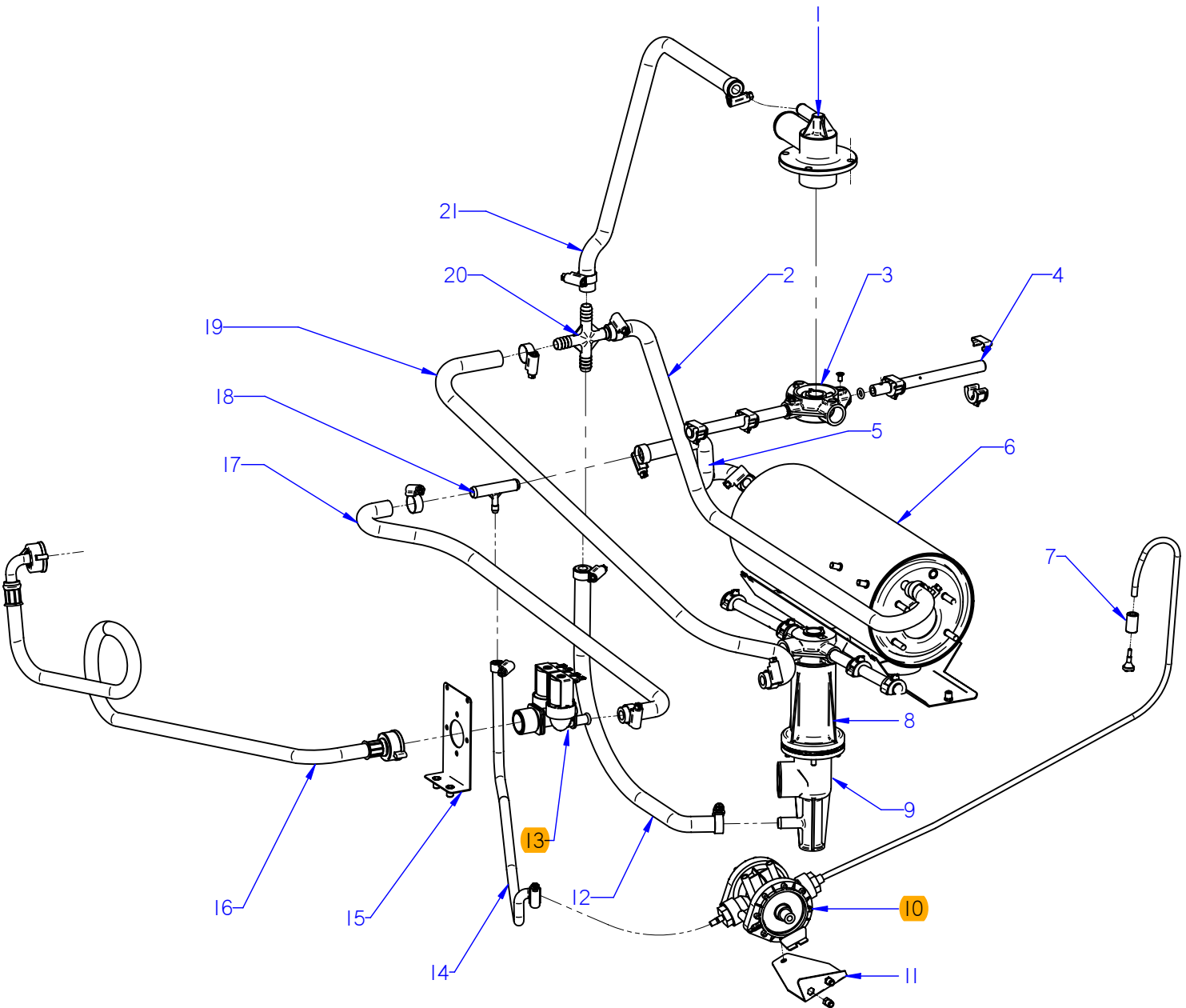

MOD.	LAVAVASOS	ZONA	CONJUNTO FUNCIONAL ACLARADO	PLANO	C-2456
------	-----------	------	-----------------------------	-------	--------

ITEM	CODIGO	DENOMINACION	TEXTO	AD-15							NOTAS
1	Z410703000	SOPORTE DISTRIBUIDOR SUPER.	UPPER DISTRIBUTION SUPPORT	1							
	Q232040000	ARANDELA A6	WASHER A6	4							
	Q262040000	ARANDELA GROW. A6 A.304	WASHER GROW. A6 A.304	4							
	Q162040000	TUERCA EXAGONAL M6	HEXAGONAL NUT M6	4							
2	3676900000	TUBO GOMA NEGRA Ø17*10	BLACK RUBBER PIPE Ø17*10	1							
	Q881302000	ABRAZADERA 12/20	CLAMP 12/20	2							
3	Z410704000	CRUCETA	CROSSPIECE	2							
	Q152016000	TORNILLO ESPECIAL M.5X0.8	SPECIAL BOLT M.5X0.8	2							
	Z410705000	CASQUILLO CRUCETA	CROSSPIECE BUSHING	4							
4	Z461901000	RAMA ACLARADO B	RINSE BRANCH B	2							
S/Nº	Z461902000	RAMA ACLARADO A	RINSE BRANCH A	2							
	Z201905000	TOBERA ACLARADO	RINSE NOZZLE	8							
	Z201906000	ENGANCHE TOB. ACLA.19728	NOZZLE LATCH RINSE.19728	8							
	Q307036000	JUNTA TORICA 5,28X8,84X1,78	O-RING 5.28X8.84X1.78	8							
	Q042021000	TORNILL. AVELLANADO M4X10 A304	COUNTERSUNK BOLT M4X10 A304	4							
5	3676900000	TUBO GOMA NEGRA Ø17*10	BLACK RUBBER PIPE Ø17*10	1							
	Q881302000	ABRAZADERA 12/20	CLAMP 12/20	2							
6	Z401730000	CALDERIN LAVAVASOS 10-2	GLASSWASHER BOILER 10-2	1							ELIMINADO 15.10.2012
6	12046994	CALDERIN COMPLETO LVS. W	GLASSWASHER BOILER 10-2	1							INTRODUCIDO 15.10.2012
7	Z701152000	PESO FILTRO	FILTER WEIGHT	1							
8	Z410701000	SOPORTE INFERIOR CUADRO	LOWER SUPPORT BRACKET	1							
9	Z410702000	PASAMUROS CESTO CUADRADO	SQUARE BASKET WALL BUSHING	1							
	Q232030000	ARANDELA A5	WASHER A5	4							
	Q262030000	ARANDELA GROW. A5 A.304	WASHER GROW. A5 A.304	4							
	Q162030000	TUERCA EXAGONAL M5	HEXAGONAL NUT M5	4							
10	Z211109000	DOSIFICADOR TENSOACTIVO N-6	SURFACE ACT. DISP. N-6	1							ELIMINADO 18.06.2012
10	12045206	DOSIFICADOR_ABRILLANTADOR_AQ	RINSE AID DISPENSER	1							INTRODUCIDO 18.06.2012
S/Nº	Z448618000	CONDUCTO ABRILLANTADOR	POLISH DUCT	1							
11	Z401116000	SOPORTE DOSIFICADOR	DISPENSER SUPPORT	1							
	Q242030000	ARANDELA ABANICO A5 A.304	FAN WASHER A5 A.304	4							
	Q152004000	TORNILLO APLASTADO M5x13 A304	FLAT HEADED BOLT M5x13 A304	2							

MOD.		LAVAVASOS		ZONA	CONJUNTO FUNCIONAL ACLARADO					PLANO	C-2456
ITEM	CODIGO	DENOMINACION	TEXTO	AD-15							NOTAS
12	3676900000	TUBO GOMA NEGRA Ø17*10	BLACK RUBBER PIPE Ø17*10	1							
	Q881302000	ABRAZADERA 12/20	CLAMP 12/20	2							
13	P255001000	ELECTROVALVULA DOBLE	DOUBLE SOLENOID VALVE	1							
14	3704000000	TUBO GOMA NEGRA Ø10,5*5	BLACK RUBBER PIPE Ø10,5*5	1							
	Q881308000	ABRAZADERA 8/14	CLAMP 8/14	2							
15	Z401111000	SOPORTE ELECTROVALVULA	SOLENOID VLVE SUPPORT	1							
	Q242030000	ARANDELA ABANICO A5 A.304	FAN WASHER A5 A.304	2							
	Q152004000	TORNILLO APLASTADO M5x13 A304	FLAT HEADED BOLT M5x13 A304	2							
	Q152024000	TORNILLO AVELLANADO M4X8 A304	COUNTERSUNK BOLT M4X8 A304	2							
16	Z601114000	MANGUERA ENTRADA AGUA	WATER INTAKE HOSE	1							
17	3676900000	TUBO GOMA NEGRA Ø17*10	BLACK RUBBER PIPE Ø17*10	1							
	Q881302000	ABRAZADERA 12/20	CLAMP 12/20	2							
18	Z601157000	TOMA PRESION	PRESSURE INTAKE	1							
19	3676900000	TUBO GOMA NEGRA Ø17*10	BLACK RUBBER PIPE Ø17*10	1							
	Q881302000	ABRAZADERA 12/20	CLAMP 12/20	2							
20	Z401108000	RACORD EN CRUZ	DIAGONAL CONNECTION	1							
21	3676900000	TUBO GOMA NEGRA Ø17*10	BLACK RUBBER PIPE Ø17*10	1							
	Q881302000	ABRAZADERA 12/20	CLAMP 12/20	2							

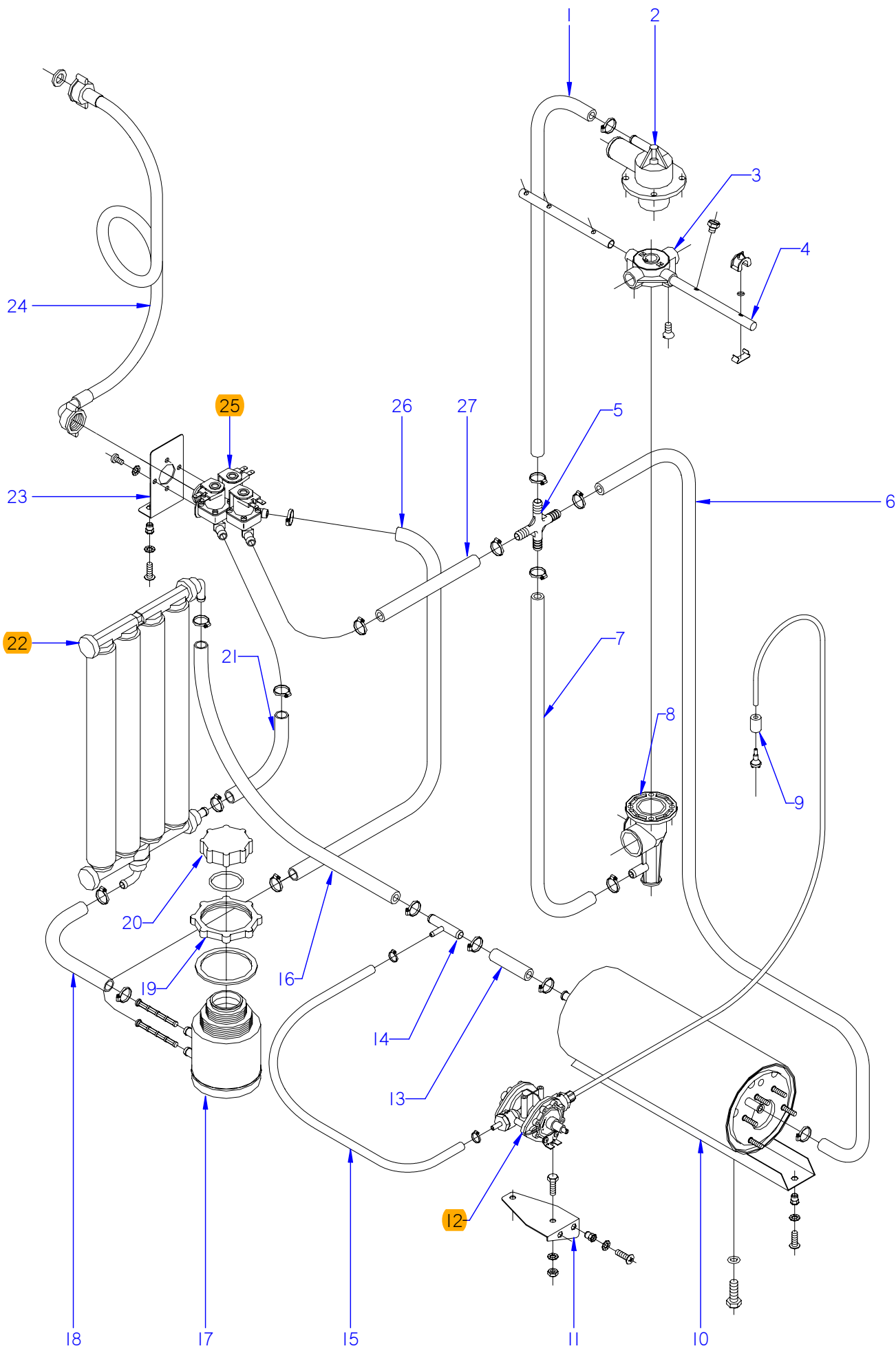

ITEM MARCADO EN COLOR = REPUESTO RECOMENDADO
 COLOURED ITEM = RECOMMENDED SPARE PART

N plano	Firma	Fecha	Aparato	CONJUNTO FUNCIONAL ACLARADO	Lamina	Fagor Industrial S.Coop. FAGOR
C-2457	<i>[Signature]</i>	2009-12	LAVAVASOS AD-15D; AD-21D		6	Oñate

MOD.		LAVAVASOS		ZONA		CONJUNTO FUNCIONAL ACLARADO				PLANO		C-2457	
ITEM	CODIGO	DENOMINACION	TEXTO	AD-15 D	AD-21 D							NOTAS	
1	3676900000	TUBO GOMA NEGRA Ø17*10	BLACK RUBBER PIPE Ø17*10	1	1								
	Q881302000	ABRAZADERA 12/20	CLAMP 12/20	2	2								
2	Z410703000	SOPORTE DISTRIBUIDOR SUPER.	UPPER DISTRIBUTION SUPPOR	1	1								
	Q232040000	ARANDELA A6	WASHER A6	4	4								
	Q262040000	ARANDELA GROW. A6 A.304	WASHER GROW. A6 A.304	4	4								
	Q162040000	TUERCA EXAGONAL M6	HEXAGONAL NUT M6	4	4								
3	Z410704000	CRUCETA	CROSSPIECE	2	2								
	Q152016000	TORNILLO ESPECIAL M.5X0.8	SPECIAL BOLT M.5X0.8	2	2								
	Z410705000	CASQUILLO CRUCETA	CROSSPIECE BUSHING	4	4								
4	Z461901000	RAMA ACLARADO B	RINSE BRANCH B	2									
4	Z441902000	RAMA ACLARADO B	RINSE BRANCH B		2								
S/Nº	Z461902000	RAMA ACLARADO A	RINSE BRANCH A	2									
S/Nº	Z441901000	RAMA ACLARADO A	RINSE BRANCH A		2								
	Z201905000	TOBERA ACLARADO	RINSE NOZZLE	8									
	Z211903000	TOBERA ACLARADO	RINSE NOZZLE		10								
	Z201906000	ENGANCHE TOB. ACLA.19728	NOZZLE LATCH RINSE.19728	8									
	Q307036000	JUNTA TORICA 5,28X8,84X1,78	O-RING 5.28X8.84X1.78	8									
	Q042021000	TORNILL. AVELLANADO M4X10 A304	COUNTERSUNK BOLT M4X10 A3	4	4								
5	Z401108000	RACORD EN CRUZ	DIAGONAL CONNECTION	1	1								
6	3676900000	TUBO GOMA NEGRA Ø17*10	BLACK RUBBER PIPE Ø17*10	1	1								
	Q881302000	ABRAZADERA 12/20	CLAMP 12/20	2	2								
7	3676900000	TUBO GOMA NEGRA Ø17*10	BLACK RUBBER PIPE Ø17*10	1	1								
	Q881302000	ABRAZADERA 12/20	CLAMP 12/20	2	2								
8	Z410702000	PASAMUROS CESTO CUADRADO	SQUARE BASKET WALL BUSHIN	1	1								
	Q232030000	ARANDELA A5	WASHER A5	4	4								
	Q262030000	ARANDELA GROW. A5 A.304	WASHER GROW. A5 A.304	4	4								
	Q162030000	TUERCA EXAGONAL M5	HEXAGONAL NUT M5	4	4								
9	Z701152000	PESO FILTRO	FILTER WEIGHT	1	1								
10	Z401730000	CALDERIN LAVAVASOS 10-2	GLASSWASHER BOILER 10-2	1	1								ELIMINADO 15.10.2012
10	12046994	CALDERIN COMPLETO LVS. W	GLASSWASHER BOILER 10-2	1	1								INTRODUCIDO 15.10.2012

MOD.		LAVAVASOS		ZONA		CONJUNTO FUNCIONAL ACLARADO				PLANO	C-2457
ITEM	CODIGO	DENOMINACION	TEXTO	AD-15 D	AD-21 D						NOTAS
11	Z401116000	SOPORTE DOSIFICADOR	DISPENSER SUPPORT	1	1						
	Q242030000	ARANDELA ABANICO A5 A.304	FAN WASHER A5 A.304	4	4						
	Q152004000	TORNILLO APLASTADO M5x13 A304	FLAT HEADED BOLT M5x13 A304	2	2						
12	Z211109000	DOSIFICADOR TENSOACTIVO N-6	SURFACE ACT. DISP. N-6	1	1						ELIMINADO 18.06.2012
12	12045206	DOSIFICADOR_ABRILLANTADOR_AQ	RINSE AID DISPENSER	1	1						INTRODUCIDO 18.06.2012
S/Nº	Z448618000	CONDUCTO ABRILLANTADOR	POLISH DUCT	1	1						
13	3676900000	TUBO GOMA NEGRA Ø17*10	BLACK RUBBER PIPE Ø17*10	1	1						
	Q881302000	ABRAZADERA 12/20	CLAMP 12/20	2	2						
14	Z601157000	TOMA PRESION	PRESSURE INTAKE	1	1						
15	3704000000	TUBO GOMA NEGRA Ø10,5*5	BLACK RUBBER PIPE Ø10,5*5	1	1						
	Q881308000	ABRAZADERA 8/14	CLAMP 8/14	2	2						
16	3676900000	TUBO GOMA NEGRA Ø17*10	BLACK RUBBER PIPE Ø17*10	1	1						
	Q881302000	ABRAZADERA 12/20	CLAMP 12/20	2	2						
17	Z471102000	DEPOSITO SOLDADO	WELDED TANK	1	1						
	Z471105000	FILTRO (BITRON 06281.01)	FILTER (BITRON 06281.01)	2	2						
18	3676900000	TUBO GOMA NEGRA Ø17*10	BLACK RUBBER PIPE Ø17*10	1	1						
	Q881302000	ABRAZADERA 12/20	CLAMP 12/20	2	2						
19	Z471106000	TUERCA (BITRON 27414.00)	NUT (BITRON 27414.00)	1	1						ELIMINADO 01.05.2012
19	12044660	TUERCA BITRON	NUT BITRON	1	1						INTRODUCIDO 01.05.2012
	Z471107000	JUNTA TUERCA (BITRON 15702.01)	NUT SEAL (BITRON 15702.01)	1	1						ELIMINADO 07.01.2013
	12047154	JUNTA TUERCA	NUT SEAL	1	1						INTRODUCIDO 07.01.2013
20	Z471108000	TAPON (BITRON 27415.00)	PLUG (BITRON 27415.00)	1	1						
	Z471109000	JUNTA TAPON (BITRON 06485.02)	PLUG SEAL (BITRON 06485.02)	1	1						
21	3676900000	TUBO GOMA NEGRA Ø17*10	BLACK RUBBER PIPE Ø17*10	1	1						
	Q881302000	ABRAZADERA 12/20	CLAMP 12/20	2	2						
22	Z471101000	DESCALCIFICADOR 4 COLUMNAS	WATER SOFTENER 4 COLUMN	1	1						
	Z471111000	SOPOR. SUPERIOR DESCALCIFICAD.	UPPER W-SOFT. SUPPORT.	1	—						
	Z491101000	SOPOR. SUPERIOR DESCALCIFICAD.	UPPER W-SOFT. SUPPORT.	—	1						
	Z471112000	SOPOR. INFERIOR DESCALCIFICAD.	LOWER W-SOFT. SUPPORT.	1	1						

MOD. **LAVAVASOS** ZONA **CONJUNTO FUNCIONAL ACLARADO** PLANO **C-2457**

ITEM	CODIGO	DENOMINACION	TEXTO	AD-15 D	AD-21 D						NOTAS
23	Z401111000	SOPORTE ELECTROVALVULA	SOLENOID VLVE SUPPORT	1	1						
	Q242030000	ARANDELA ABANICO A5 A.304	FAN WASHER A5 A.304	2	2						
	Q152004000	TORNILLO APLASTADO M5x13 A304	FLAT HEADED BOLT M5x13 A304	2	2						
	Q152024000	TORNILLO AVELLANADO M4X8 A304	COUNTERSUNK BOLT M4X8 A304	2	2						
24	Z602121000	MANGUERA ENTRADA AGUA	WATER INTAKE HOSE	1	1						
25	Z611124000	(12Z6111240) ELECTROVAL. TRIPLE	(12Z6111240) SOLENOID VALVE	1	1						
26	3676900000	TUBO GOMA NEGRA Ø17*10	BLACK RUBBER PIPE Ø17*10	1	1						
	Q881302000	ABRAZADERA 12/20	CLAMP 12/20	2	2						
27	3676900000	TUBO GOMA NEGRA Ø17*10	BLACK RUBBER PIPE Ø17*10	1	1						
	Q881302000	ABRAZADERA 12/20	CLAMP 12/20	2	2						

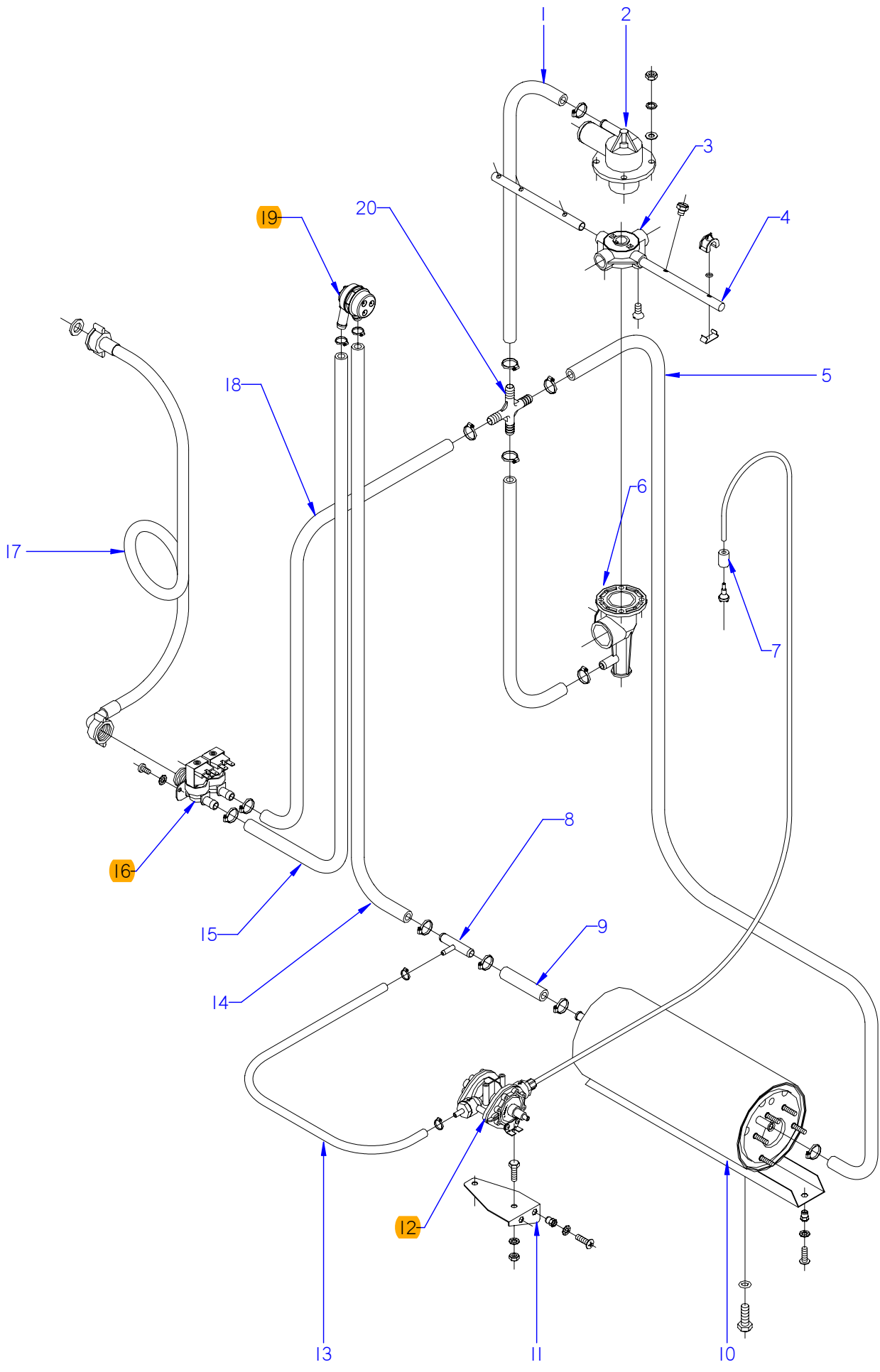

ITEM MARCADO EN COLOR = REPUESTO RECOMENDADO
 COLOURED ITEM = RECOMMENDED SPARE PART

N plano	Firma	Fecha	Aparato	CONJUNTO FUNCIONAL ACLARADO	Lamina	Fagor Industrial S.Coop. FAGOR
C-2458	<i>[Signature]</i>	2009-12	LAVAVASOS AD-21;B; B DD; DD		7	Oñate

MOD.		LAVAVASOS		ZONA		CONJUNTO FUNCIONAL ACLARADO		PLANO		C-2458	
ITEM	CODIGO	DENOMINACION	TEXTO	AD-21	AD-21 B	AD-21 B DD	AD-21 DD				NOTAS
1	3676900000	TUBO GOMA NEGRA Ø17*10	BLACK RUBBER PIPE Ø17*10	2	2	2	2				
	Q881302000	ABRAZADERA 12/20	CLAMP 12/20	6	6	6	6				
2	Z410703000	SOPORTE DISTRIBUIDOR SUPER.	UPPER DISTRIBUTION SUPPORT	1	1	1	1				
	Q232040000	ARANDELA A6	WASHER A6	4	4	4	4				
	Q262040000	ARANDELA GROW. A6 A.304	WASHER GROW. A6 A.304	4	4	4	4				
	Q162040000	TUERCA EXAGONAL M6	HEXAGONAL NUT M6	4	4	4	4				
3	Z410704000	CRUCETA	CROSSPIECE	2	2	2	2				
	Q152016000	TORNILLO ESPECIAL M.5X0.8	SPECIAL BOLT M.5X0.8	2	2	2	2				
	Z410705000	CASQUILLO CRUCETA	CROSSPIECE BUSHING	4	4	4	4				
4	Z441902000	RAMA ACLARADO B	RINSE BRANCH B	2	2	2	2				
S/Nº	Z441901000	RAMA ACLARADO A	RINSE BRANCH A	2	2	2	2				
	Z211903000	TOBERA ACLARADO	RINSE NOZZLE	10	10	10	10				
	Q042021000	TORNILL. AVELLANADO M4X10 A304	COUNTERSUNK BOLT M4X10 A304	4	4	4	4				
5	3676900000	TUBO GOMA NEGRA Ø17*10	BLACK RUBBER PIPE Ø17*10	1	1	1	1				
	Q881302000	ABRAZADERA 12/20	CLAMP 12/20	1	1	1	1				
6	Z410702000	PASAMUROS CESTO CUADRADO	SQUARE BASKET WALL BUSHING	1	1	1	1				
	Q232030000	ARANDELA A5	WASHER A5	4	4	4	4				
	Q262030000	ARANDELA GROW. A5 A.304	WASHER GROW. A5 A.304	4	4	4	4				
	Q162030000	TUERCA EXAGONAL M5	HEXAGONAL NUT M5	4	4	4	4				
7	Z701152000	PESO FILTRO	FILTER WEIGHT	1	1	1	1				
8	Z601157000	TOMA PRESION	PRESSURE INTAKE	1	1	1	1				
9	3676900000	TUBO GOMA NEGRA Ø17*10	BLACK RUBBER PIPE Ø17*10	1	1	1	1				
	Q881302000	ABRAZADERA 12/20	CLAMP 12/20	4	4	4	4				
10	Z401730000	CALDERIN LAVAVASOS 10-2	GLASSWASHER BOILER 10-2	1	1	1	1				ELIMINADO 15.10.2012
10	12046994	CALDERIN COMPLETO LVS. W	GLASSWASHER BOILER 10-2	1	1	1	1				INTRODUCIDO 15.10.2012
11	Z401116000	SOPORTE DOSIFICADOR	DISPENSER SUPPORT	1	1	1	1				
	Q242030000	ARANDELA ABANICO A5 A.304	FAN WASHER A5 A.304	4	4	4	4				
	Q152004000	TORNILLO APLASTADO M5x13 A304	FLAT HEADED BOLT M5x13 A304	2	2	2	2				
12	Z211109000	DOSIFICADOR TENSOACTIVO N-6	SURFACE ACT. DISP. N-6	1	1	1	1				ELIMINADO 18.06.2012
12	12045206	DOSIFICADOR ABRILLANTADOR_AQ	RINSE AID DISPENSER	1	1	1	1				INTRODUCIDO 18.06.2012
S/Nº	Z448618000	CONDUCTO ABRILLANTADOR	POLISH DUCT	1	1	1	1				

MOD.	LAVAVASOS	ZONA	CONJUNTO FUNCIONAL ACLARADO	PLANO	C-2458
------	-----------	------	-----------------------------	-------	--------

ITEM	CODIGO	DENOMINACION	TEXTO	AD-21	AD-21 B	AD-21 B DD	AD-21 DD					NOTAS
13	3704000000	TUBO GOMA NEGRA Ø10,5*5	BLACK RUBBER PIPE Ø10,5*5	1	1	1	1					
	Q881308000	ABRAZADERA 8/14	CLAMP 8/14	2	2	2	2					
14	3676900000	TUBO GOMA NEGRA Ø17*10	BLACK RUBBER PIPE Ø17*10	1	1	1	1					
	Q881302000	ABRAZADERA 12/20	CLAMP 12/20	2	2	2	2					
15	3676900000	TUBO GOMA NEGRA Ø17*10	BLACK RUBBER PIPE Ø17*10	1	1	1	1					
	Q881302000	ABRAZADERA 12/20	CLAMP 12/20	2	2	2	2					
16	P255001000	ELECTROVALVULA DOBLE	DOUBLE SOLENOID VALVE	1	1	1	1					
17	Z601114000	MANGUERA ENTRADA AGUA	WATER INTAKE HOSE	1	1	1	1					
18	3676900000	TUBO GOMA NEGRA Ø17*10	BLACK RUBBER PIPE Ø17*10	1	1	1	1					
	Q881302000	ABRAZADERA 12/20	CLAMP 12/20	2	2	2	2					
19	Z231106000	VALVULA ANTIRRETORNO	NON-RETURN VALVE	1	1	1	1					
	Q881302000	ABRAZADERA 12/20	CLAMP 12/20	2	2	2	2					
20	Z401108000	RACORD EN CRUZ	DIAGONAL CONNECTION	1	1	1	1					

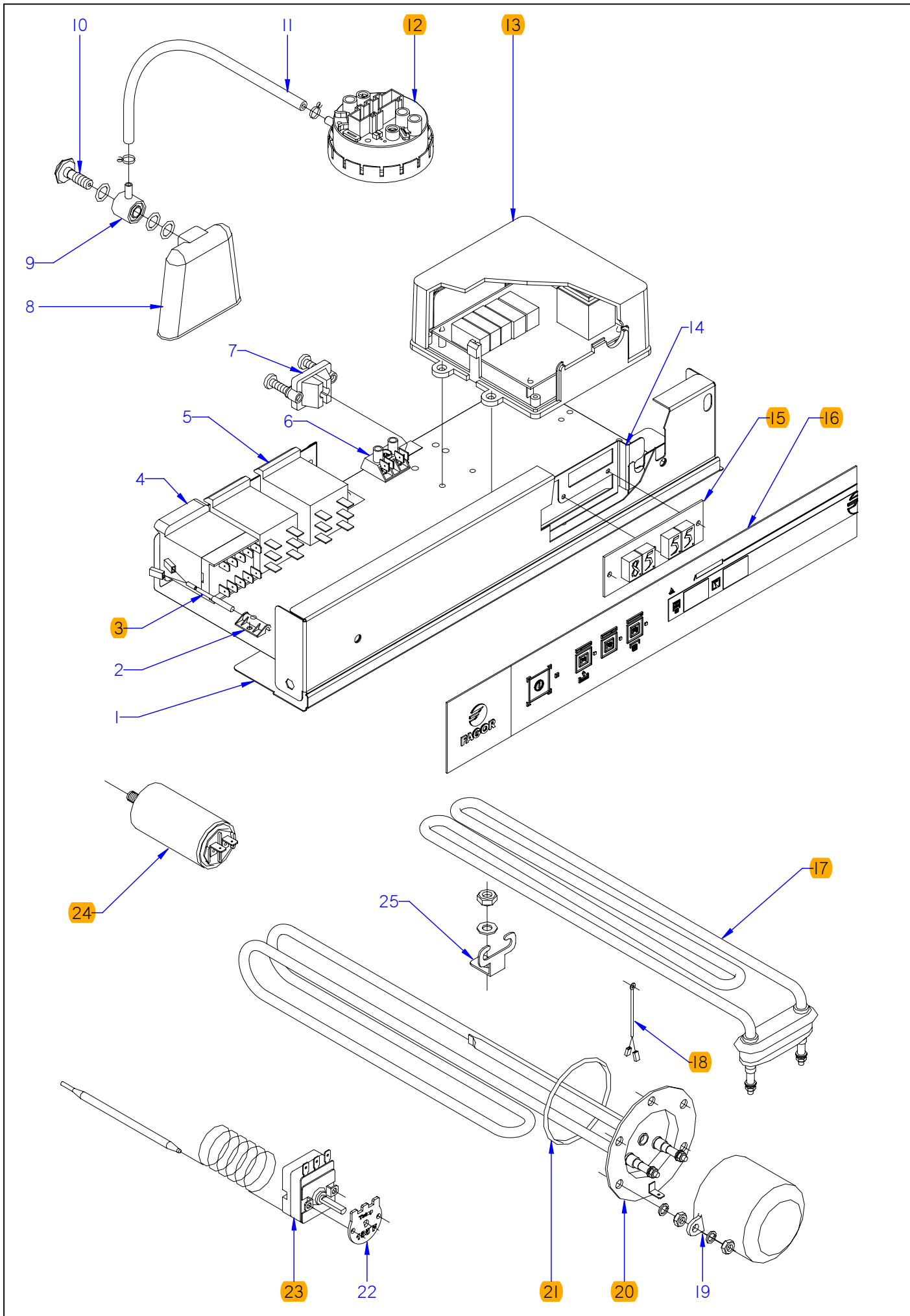

ITEM MARCADO EN COLOR = REPUESTO RECOMENDADO
 COLOURED ITEM = RECOMMENDED SPARE PART

N plano	Firma	Fecha	Aparato	CONJUNTO FUNCIONAL ELECTRICO	Lamina	Fagor Industrial S.Coop. FAGOR
C-2459	<i>[Signature]</i>	2009-12	LAVAVASOS AD		8	Oñate

MOD.		LAVAVASOS		ZONA	CONJUNTO FUNCIONAL ELECTRICO						PLANO	C-2459
ITEM	CODIGO	DENOMINACION	TEXTO	AD-15	AD-15 D	AD-21	AD-21 B	AD-21B DD	AD-21 D	AD-21 DD		NOTAS
1	Z412910000	FRENTE COMPLETO AD-15	COMPLETE FRONT AD-15	1	1							
1	Z442911000	FRENTE COMPLETO AD-21	COMPLETE FRONT AD-21			1	1	1	1	1		
1	Z448402000	FRENTE COMPLETO AD-21 W	COMPLETE FRONT AD-21 W									
	Q152004000	TORNILLO APLASTADO M5x13 A304	FLAT HEADED BOLT M5x13 A304	2	2	2	2	2	2	2		
2	Z203010000	AMARRE INTERRUPT. MAGNETICO	MAGNETIC SWITCH FASTENER	1	1	1	1	1	1	1		
	Q232030000	ARANDELA A5	WASHER A5	1	1	1	1	1	1	1		
	Q152004000	TORNILLO APLASTADO M5x13 A304	FLAT HEADED BOLT M5x13 A304	1	1	1	1	1	1	1		
	Q162030000	TUERCA EXAGONAL M5	HEXAGONAL NUT M5	1	1	1	1	2	1	2		
3	Z203009000	INTERRUPTOR MAGNETICO	MAGNETIC SWITCH	1	1	1	1	1	1	1		
4	12024011	CONTACTOR 230 V. 50-60 HZ	CONTACTOR 230 V. 50-60 HZ	1	1	1	1	1	1	1		ELIMINAD. 15.10.12
4	12024011	CONTACTOR 230 V. 50-60 HZ	CONTACTOR 230 V. 50-60 HZ	2	2	2	2	2	2	2		INTRODUC. 15.10.12
5	12023706	RELE 230V. 16A 50-60 HZ	RELAY 230V. 16A 50-60 HZ	2	2	2	2	2	2	2		ELIMINAD. 15.10.12
5	12023706	RELE 230V. 16A 50-60 HZ	RELAY 230V. 16A 50-60 HZ	1	1	1	1	1	1	1		INTRODUC. 15.10.12
5	Z683087000	CONTACTOR 3TF20 01-3AL2 230	CONTACTOR 3TF20 01-3AL2	1	1	1	1	1	1	1		INTRODUC.14.05.10
5	Z683087000	CONTACTOR 3TF20 01-3AL2 230	CONTACTOR 3TF20 01-3AL2	1	1	1	1	1	1	1		ELIMINAD. 01.06.11
6	Z603025000	REGLETA DE CONEXIONES	CONNECTION STRIP	1	1	1	1	1	1	1		
S/Nº	12045569	BORNAS PORTAFUSIB. 13A 2,5	FUSE HOLDER TERMINAL 13A	1	1	1	1	1	1	1		INTRODUC. 18,06,12
	Q032021000	TORNILLO ALOMADO M4X10	CURVED SCREW M4X10	1	1	1	1	1	1	1		
	Q162020000	TUERCA EXAGONAL M4	HEXAGONAL NUT M4	1	1	1	1	1	1	1		
7	Z203020000	RETENEDOR DE CABLE	CABLE HOLDER	1	1	1	1	1	1	1		
8	Z203011000	CAMARA PRESOSTATO	PRESSURE SWITCH	1	1	1	1	1	1	1		
9	Z203012000	EMPALME PRESOSTATO	PRESSURE SWITCH CONNEX	1	1	1	1	1	1	1		
10	Z203013000	TORNILLO PRESOSTATO	PRESSURE SWITCH BOLT	1	1	1	1	1	1	1		
	Q307003000	JUNTA TORICA 16.01X10.77X2.62	O-RING 16.01X10.77X2.62	3	3	3	3	3	3	3		
11	3702400000	TUBO GOMA NEGRO D 8*4	BLACK RUBBER PIPE Ø 8*4	1	1	1	1	1	1	1		
	P102154000	BRIDA ELASTICA TUBO	ELASTIC PIPE FLANGE	2	2	2	2	2	2	2		
12	Z403021000	PRESOSTATO SIMPLE	SIMPLE PRESSURE SWITCH	1	1	1			1	1		
12	Z433011000	PRESOSTATO DOBLE	DOUBLE PRESSURE SWITCH				1	1				
S/Nº	Z218002000	ESCUADRA AMARRE PRESOSTATO	PRESSURE SWITCH SQUARE	1	1	1	1	1	1	1		
	Q082032000	TORNILLO ALOMADO BZ-3,5X9,5	ALOM. BOLT BZ-3,5X9,5	1	1	1	1	1	1	1		
	Q419005000	REMACHE 4X8 ALMG3 / ALUMINIO	RIVET 4X8 ALMG3 / ALUMINIUM	1	1	1	1	1	1	1		

MOD.		LAVAVASOS		ZONA		CONJUNTO FUNCIONAL ELECTRICO					PLANO		C-2459
ITEM	CODIGO	DENOMINACION	TEXTO	AD-15	AD-15 D	AD-21	AD-21 B	AD-21B DD	AD-21 D	AD-21 DD		NOTAS	
13	Z213069000	TARJETA 5 RELES GICAR	CHAMBER 5 RELAY GICAR	1	1	1	1	1	1	1		ELIMINAD. 01.06.11	
13	Z213073000	TARJETA 5 RELES	CHAMBER 5 RELAY	1	1	1	1	1	1	1		ELIMINAD. 28.01.13	
13	12048170	TARJETA 230V AC 50/60Hz 5 REL. UL	CHAMBER 230V AC 50/60Hz 5 R	1	1	1	1	1	1	1		ELIMINAD. 02.09.13	
13	12008750	TARJETA 230V AC 50/60Hz 5 REL. UL	CHAMBER 230V AC 50/60Hz 5 R	1	1	1	1	1	1	1		INTRODUC. 02.09.13	
	Q232020000	ARANDELA A4	WASHER A4	4	4	4	4	4	4	4			
	Q042022000	TORN. AVELLANADO M4X15	COUNTERSUNK BOLT M4X15	4	4	4	4	4	4	4			
14	Z203088000	SOPORTE COMPONENTES	COMPON. SUPPORT	1	1	1	1	1	1	1			
14	Z218432000	SOPORTE DISPLAY T ^a ADVANCE	DISPLAY T ^a ADV. SUPPORT	1	1	1	1	1	1	1			
	Q262030000	ARANDELA GROW. A5 A.304	WASHER GROW. A5 A.304	2	2	2	2	2	2	2			
	Q162030000	TUERCA EXAGONAL M5	HEXAGONAL NUT M5	2	2	2	2	2	2	2			
	R663036000	FIJACION CIRCUITO	CIRCUIT BINDINGS	3	3	3	3	3	3	3		ELIMINAD. 29.10.10	
15	Z713017000	DISPLAY GICAR TEMPERATURAS	DISPLAY GICAR	1	1	1	1	1	1	1			
15	Z218433000	DISPLAY T ^a ADVANCE W	DISPLAY T ^a ADVANCE W	1	1	1	1	1	1	1			
16	Z412905000	EMBELLECED. ADHESIVO AD-15	ADHES. TRIM AD-15	1	1	1	1	1	1	1			
16	Z412903000	EMBELLECED. ADHESIVO AD-15D	ADHES. TRIM AD-15D	1	1	1	1	1	1	1			
16	Z442906000	EMBELLECED. ADHESIVO AD-21	ADHES. TRIM AD-21	1	1	1	1	1	1	1			
16	Z452909000	EMBELLECED. ADHESIVO AD-21C	ADHES. TRIM AD-21C	1	1	1	1	1	1	1			
16	Z452911000	EMBELLECED. ADHESIVO AD-21D	ADHES. TRIM AD-21D	1	1	1	1	1	1	1			
16	Z448401000	EMBELLECED. ADHESIVO AD-21W	ADHES. TRIM AD-21W	1	1	1	1	1	1	1			
17	R223005000	RESISTENCIA TANQUE	TANK RESISTOR	1	1	1	1	1	1	1			
18	Z713028000	SONDA TEMPERATURA GICAR	TEMPERATURA PROBE GICAR	1	1	1	1	1	1	1			
18	Z268004000	SONDA TEMPERATURA GICAR	TEMPERATURA PROBE GICAR	1	1	1	1	1	1	1			
19	Z401713000	CAPERUZA RESISTENC. CALDERIN	BOILER RESIST. CAP	1	1	1	1	1	1	1			
	Q163140000	TUERCA EXAGONAL M6 LATON	HEXAGONAL NUT M6 BRASS	2	2	2	2	2	2	2			
	Q242030000	ARANDELA ABANICO A5 A.304	FAN WASHER A5 A.304	2	2	2	2	2	2	2			
	Q152004000	TORNILLO APLASTADO M5x13 A304	FLAT HEADED BOLT M5x13 A304	2	2	2	2	2	2	2			
20	Z401738000	RESISTENCIA CALDERIN 2400W	BOILER RESISTOR 2400W	1	1	1	1	1	1	1			
20	Z421712000	RESISTENCIA CALDERIN 2800W	BOILER RESISTOR 2800W	1	1	1	1	1	1	1			
	Q221305000	TUERCA EXAGONAL M4 ZINCADA	HEXAGONAL NUT M4 ZIN.	2	2	2	2	2	2	2			
	Q163140000	TUERCA EXAGONAL M6 LATON	HEXAGONAL NUT M6 BRASS	5	5	5	5	5	5	5			
	Q262040000	ARANDELA GROW. A6 A.304	WASHER GROW. A6 A.304	5	5	5	5	5	5	5			

MOD.		LAVAVASOS		ZONA		CONJUNTO FUNCIONAL ELECTRICO					PLANO		C-2459
ITEM	CODIGO	DENOMINACION	TEXTO	AD-15	AD-15 D	AD-21	AD-21 B	AD-21 B DD	AD-21 D	AD-21 DD		NOTAS	
21	Q307053000	JUNTA TORICA 43.82X54.48X5.35	"O" RING 43.82X54.48X5.35	1	1	1	1	1	1	1			
22	Z718446000	CHAPA W 85°C	W 85°C PLATE	1	1	1	1	1	1	1		ELIMINAD. 01.11.12	
23	Z393005000	TERMOSTATO CALDERIN	WASH DRUM THERMOSTAT	2	2	2	2	2	2	2			
	Q152024000	TORNILLO AVELLANADO M4X8 A304	COUNTERSUNK BOLT M4X8 A304	2	2	2	2	2	2	2			
24	V817100000	CONDENSADOR 6 M.F.	CONDENSER 6 M.F.	1	1	1	1	1	1	1			
25	Z603602000	SOPORTE RESISTENCIATANQUE	TANK RESISTOR SUPPORT	1	1	1	1	1	1	1			
	Q232040000	ARANDELA A6	WASHER A6	1	1	1	1	1	1	1			
	Q162040000	TUERCA EXAGONAL M6	HEXAGONAL NUT M6	1	1	1	1	1	1	1			

MOD.		LAVAVASOS		ZONA		VARIOS					PLANO		
ITEM	CODIGO	DENOMINACION	TEXTO	AD-15	AD-15 D	AD-21	AD-21 B	AD-21 B DD	AD-21 D	AD-21 DD		NOTAS	
	Z416101000	FOLLETO INSTRUCCIONES LVS AD	INSTRUCTION LEAFL. LVS AD	1	1	1	1	1	1	1			
	Z403042000	ESQUEMA TEORICO LAVAVA.AD	THEORETICAL DIAGRAM AD	1	1	1	1	1	1	1		PLANO HC-18213	
	Z403043000	ESQUEMA MONTAJE LAVAVA AD	ASSEMBLY DIAGRAM AD	1	1	1	1	1	1	1		PLANO HC-18214	
	Z403041000	INSTALACION ELECT. LAVAVAS. AD	ELEC. INSTALATION AD	1	1	1	1	1	1	1			
	12023746	CABLE ALIMENTACION	SUPPLY CABLE	1	1	1	1	1	1	1			
	12025115	CABLEADO CONEXIÓN SONDAS	PROBE CONNECTION WIRING	1	1	1	1	1	1	1			
	12023672	CABLE CONEXION PLACA-DISPLAY	DISPLAY CONNECTI. WIRING	1	1	1	1	1	1	1			
	12024314	CABLEADO DOSIFICADOR DTGTE.	DETERGENT DISP. WIRING					1		1			
	12024183	CABLEADO TIERRA M.BOMBA	PUMP LAND WIRING	1	1	1	1	1	1	1		INTRODUC.17.09.10	

AD 15, AD 21, AD 15 B, AD 21 B, AD 15 D, AD 21 D, AD 15 C, AD 21 C, AD 21 AR+DD, AD 21 W

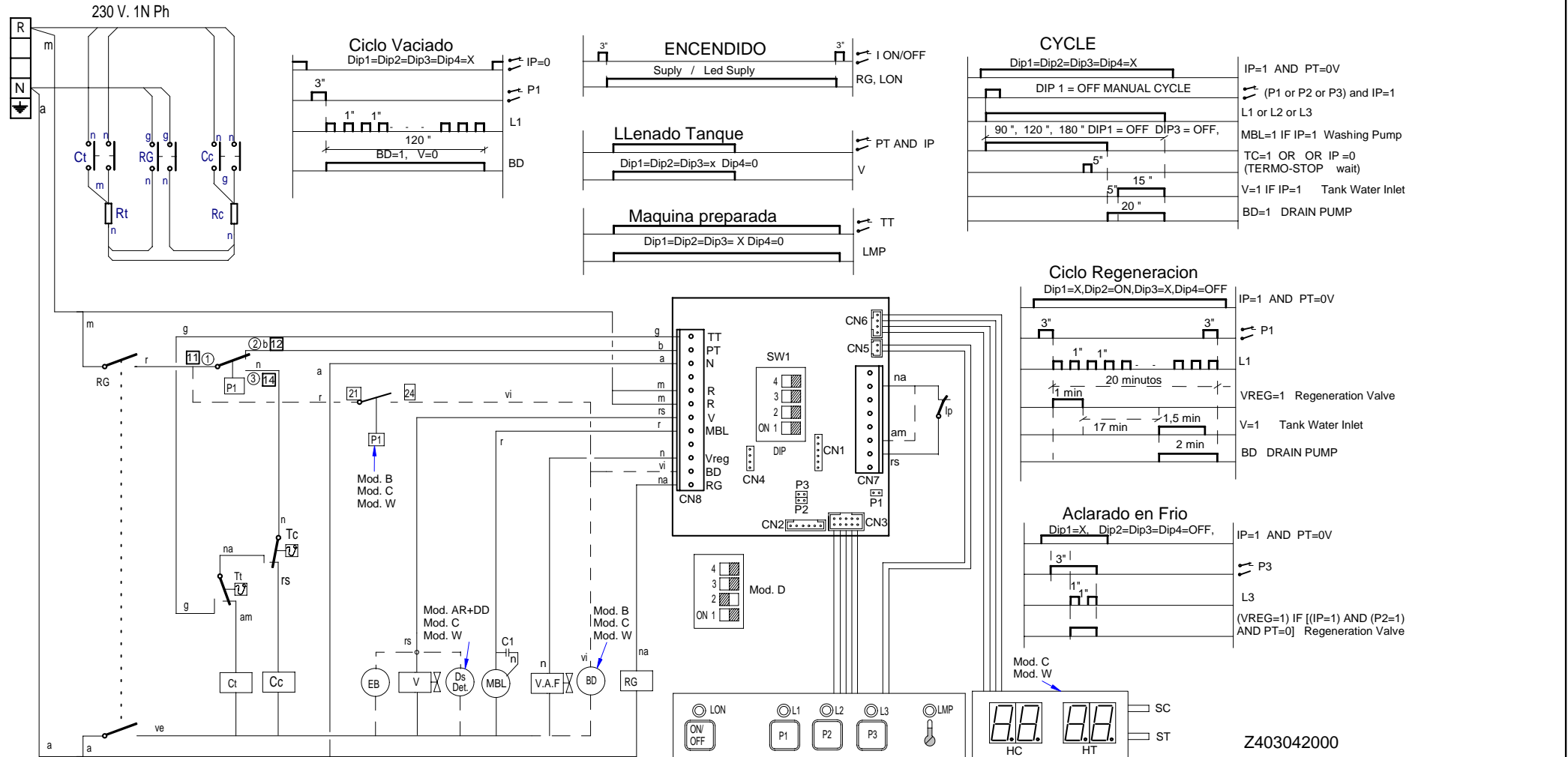

Z403042000

-	Esquema teorico LAVAVASOS AD	-	-	Z403042000	-
Zk./Nº	Pieza	Cant.	Materiala/Material	Klas. zk/Nº Clas.	Gainazal akabera/Tratamiento
Zk./Nº	Aldaketa/Modificaciones		Nork proposatua/Propuesta de	Data/Fecha	Perdoi orokorrak Tolerancias generales
.	.		.	.	< 5 ± 0.2
.	.		.	.	50 ÷ 100 ± 0.8
.	.		.	.	5 ÷ 25 ± 0.4
.	.		.	.	>100 ± 1
.	.		.	.	25 ÷ 50 ± 0.6
.	.		.	.	α ± 1
	Sinadura/Firma	Data/Fecha	 Fagor Industrial, Koop. Elk. Mugatua		Gainazal perdoia Mecanizado superficial
	Marraztua/Dibujado	M. Mailló 30-05-2009			
	Proiektatua/Proyectado	M. Mailló 30-05-2009			
	Egiatzatua/Comprobado	z. Alube 30-05-2009			
	Eskala/Escala	<h2>LAVAVASOS</h2>			Plano Zk./Plano Nº HC - 18213
					Plano hau ezin daiteke erabili, ez berrizatu, gure baimenik gabe.

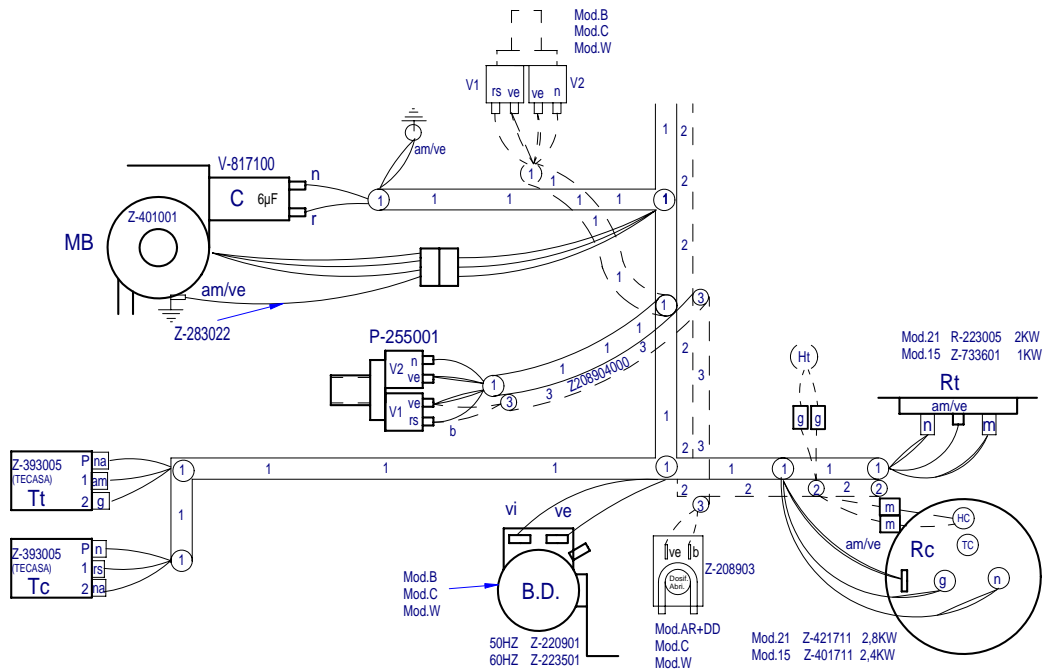
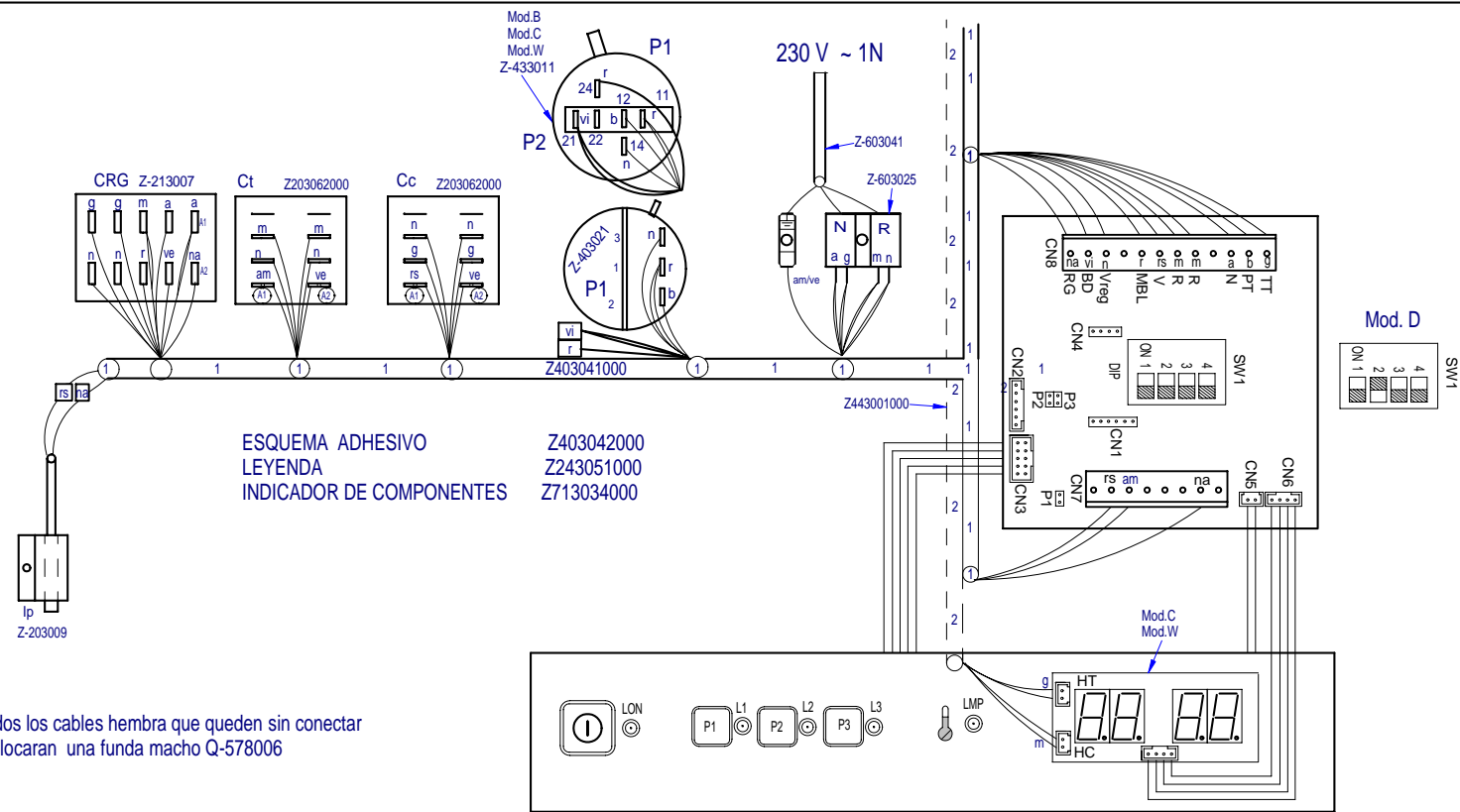

Plano montaje LAVAVASOS GICAR		Z403043000	
Nº Pieza	Material	Nº Clasificación	Acabado
Nº Modificación	Propuesta de	Fecha	Tolerancias generales
			<5± : 50-100± : 5-25± : >100± : 25-60± : ∞±
Dibujado	Firma	Fecha	Mecanizado superficial
Proyectado	M.Maillo	28-05-2009	FAGOR
Comprobado	M.Maillo	28-05-2009	
Escala	Z.Altube	28-05-2009	Fagor Industrial,Koop.EIk, Mugatua
LAVAVASOS			Plano numero HC-18214 - 00
Plano hau ez daiteke erabili ez berrizta gure baimenitz gabe			Sustituye al Nº Sustituido por

LEYENDA APERTURA FRONTAL

	ESPAÑOL	FRANÇAIS	ENGLISH	DEUTSCH	ITALIANO
BD	Bomba desagüe	Pompe de vidange	Drain pump	Abflußpumpe	Pompa scarico
C 1/2/3	Condensador	Condensateur	Condenser	Kondensator	Condensatore
CMB	Contactora bomba lavado	Contacteur pompe lavage	Wash pump contactor	Kontaktschutz Waschpumpe	Contattore pompa lavaggio
Cc 1/2	Contactora calentamiento calderin	Contacteur chauff. surchauffeur	Boiler heating contactor	Kontaktschutz Boilerheizung	Contattore riscaldamento boiler
Ct	Contactora calentamiento tanque	Contacteur chauffage cuve	Tank heating contactor	Kontaktschutz Heizung Tank	Contattore riscaldamento serbatoio
CP	Rele puerta	Relais porte	Door relay	Türrelais	Rele porta
Ds.Det.	Dosificador detergente	Dosseur de detergent	Detergent doser	Dosierer Spülmittel	Dosatore detersivo
E.B	Electrobomba de presion	Electropompe de pression	Electric pressure pump	Elektro-Drucksteigerungspumpe	Electropompa pressione
IG	Interruptor general	Interrupteur general	Main switch	Hauptschalter	Interruttore generale
IP	Micro puerta	Micro porte	Door microswitch	Mikroschalter Tür	Micro porta
L1	Piloto de encendido	Voyant fonctionnement	Operation light	Betriebsanzeigelampe	Spia accensione
L2	Piloto marcha	Voyant demarrage	Start light	Startanzeigelampe	Spia avvio
L3	Piloto maquina preparada	Voyant machine prêt	Light machine ready	Betriebsbereitschaftsanzeigelampe	Pilota macchina preparata
MBL	Bomba lavado	Pompe lavage	Wash pump	Waschpumpe	Pompa lavaggio
M	Motor programador	Moteur du programmeur	Motor programmer	Motor Programmiervorrichtung	Motore programmatore
M Av. R	Motor program. avance rapido	Moteur du progr.avance rapide	Motor program. rapid advance	Motor Programmiervorrich. schneller Vorlauf	Motore programmatore avanzamento rapido
M1	Micro programador marcha	Micro du programm. de marche	Micro programmer on	Motor Programmiervorrich. Betrieb	Micro programma. di funzionamento
M2	Micro programador lavado	Micro du programm. de lavage	Micro programmer wash	Motor Programmiervorrich. Waschen	Micro programmatore di lavaggio
M3	Micro programador aclarado	Micro du programm. de rinçage	Micro programmer on	Motor Programmiervorrich. Spülen	Micro programmatore di risciacquo
M4	Micro programador Termo-stop	Micro du programm. Thermo-stop	Micro programmer Thermo-stop	Motor Programmiervorrich. Thermo-Stop	Micro programmatore Thermo-stop
M5	Micro programador avance	Micro du programm. avance	Micro programmer advance	Motor Programmiervorrich. Vorlauf	Micro programmatore avanzamento
P, P1, P5	Presostato	Pressostat	Pressure switch	Druckwächter	Pressostato
P2, P3, P4	Presostato limitador	Pressostat de securité	Hi-limit pressure switch	Begrenzer Druckwächter	Pressostato limitatore
RC	Resistencia calderin	Resistance surchauffeur	Boiler heating element	Heizwiderstand Boiler	Resistenza boiler
RT	Resistencia tanque	Resistance cuve	Tank heater	Heizwiderstand Tank	Resistenza serbatoio
Tt	Termostato tanque	Thermostat de cuve	Tank thermostat	Thermostat Tank	Termostato serbatoio
TC	Termostato calderin	Thermostat surchauffeur	Boiler thermostat	Thermostat kessel	Termostato boiler
TSC	Limitador calderin	Limiteur surchauffeur	Boiler Hi-limit	Begrenzer Boiler	Limitatore boiler
TSTP	Termostato termo-stop	Thermostat Thermo-stop	Thermo-stop Thermostat	Thermostat Thermo-stop	Termostato Thermo-stop
V	Electrovalvula llenado y aclarado	Electrovan. remplissage rinçage	Fill and rinse valve	Elektroventil Füllen und Spülen	Elettroval. riempimento e risciacquo
COLOR	COLORES	COULEURS	COLOUR	FARBEN	COLORE
a =	Azul	Bleu	Blue	Blau	Blu
am =	Amarillo	Jaune	Yellow	Gelb	Giallo
am/ve =	Amarillo/verde	Jaune / vert	Yellow / green	Gelb/grün	Giallo/verde
b =	Blanco	Blanc	White	Weiß	Bianco
g =	Gris	Gris	Grey	Grau	Grigio
m =	Marrón	Marron	Brown	Braun	Marrone
n =	Negro	Noir	Black	Schwarz	Nero
na =	Naranja	Orange	Orange	Orange	Arancio
r =	Rojo	Rouge	Red	Rot	Rosso
rs =	Rosa	Rose	Pink	Rosa	Roseo
ve =	Verde	Vert	Green	Grün	Verde
vi =	Violeta	Violet	Purple	Violett	Viola

Z243051000