

**Lavavajillas de Arrastre Compactos
Compact Conveyor Dishwashers
Lavevaisselle d'avancement Compactes
Korbtransport-Geschirrspülmaschinen
Lavastoviglie a trascinamento Compatte**

LAVADO DE VAJILLA

Modelos:

FI-160

FI-200

FI-200 H

ECO-160

ECO-200

ECO-200 H

Mayo 2001 May

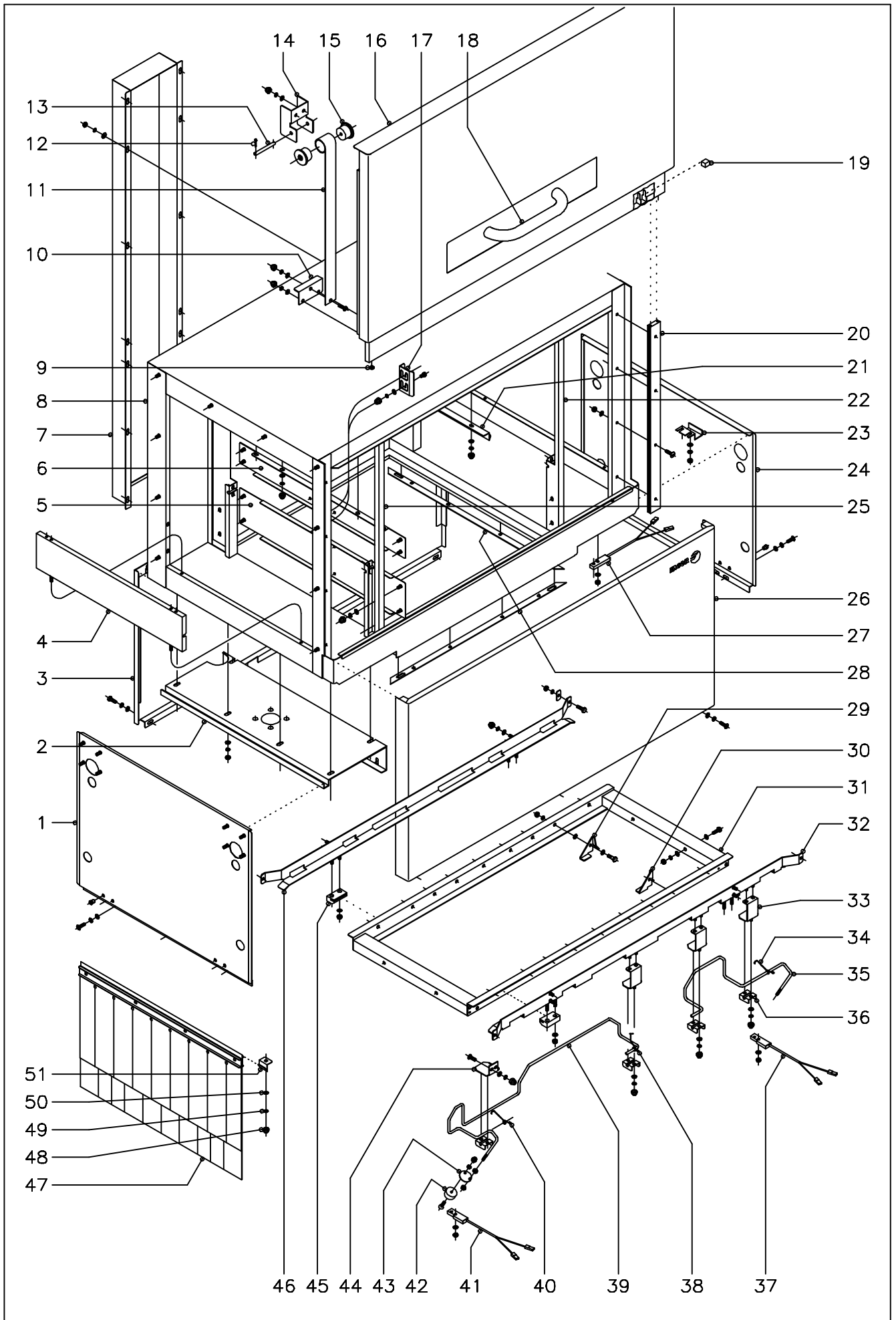

N plano C-1035	Firma 	Fecha 5-2001	Aparato LAVAJILLAS ARRASTRE COMPACTO TUNEL DE LAVADO Y ACLARADO	Lamina 1	Fagor Industrial S.Coop. FAGOR Oñate
-------------------	-----------	-----------------	---	-------------	--

MOD.		LAVAVAJILLAS ARRASTRE COMPACTO		ZONA		TUNEL DE LAVADO Y ACLARADO				PLANO		C-1035	
ITEM	CODIGO	DENOMINACION	TEXTO	FI y ECO -160 IZDA.	FI y ECO -200 IZDA.	FI y ECO -160 DCHA.	FI y ECO -200 DCHA.						NOTAS
1	Z272936	Panel lateral		1	1	1	1						
	Q221342	Remache exagonal M-5		2	2	2	2						
	Q232040	Arandela plana A-6		2	2	2	2						
	Q262030	Arandela muelle A-5		2	2	2	2						
	Q152004	Tornillo aplastado M-5x13		2	2	2	2						
2	Z270341	Refuerzo soporte		1	1	1	1						
	Q232040	Arandela plana A-6		8	8	8	8						
	Q262040	Arandela muelle A-6		8	8	8	8						
	Q162040	Tuerca exagonal M-6		8	8	8	8						
3	Z272935	Panel posterior completo		1	1	1	1						
	Q232040	Arandela plana A-6		3	3	3	3						
	Q262030	Arandela muelle A-5		3	3	3	3						
	Q152004	Tornillo aplastado M-5x13		3	3	3	3						
4	Z270337	Suplemento salida tunel		1	1	1	1						Cuando no lleva tunel de salida
	Q232040	Arandela plana A-6		4	4	4	4						Cuando no lleva tunel de salida
	Q262030	Arandela muelle A-5		4	4	4	4						Cuando no lleva tunel de salida
	Q212031	Tuerca sombrerete M-5		4	4	4	4						Cuando no lleva tunel de salida
	Q152004	Tornillo aplastado M-5x13		2	2	2	2						Cuando no lleva tunel de salida
5	Z270330	Inferior portico		2	2	2	2						
	Q232040	Arandela plana A-6		8	8	8	8						
	Q262030	Arandela muelle A-5		8	8	8	8						
	Q212031	Tuerca sombrerete M-5		8	8	8	8						
6	Z270332	Superior portico		2	2	2	2						
	Q232040	Arandela plana A-6		18	18	18	18						
	Q262030	Arandela muelle A-5		18	18	18	18						
	Q212031	Tuerca sombrerete M-5		18	18	18	18						
7	Z313049	Cubierta posterior cuadro electrico		1	1	1	1						
	Q232040	Arandela plana A-6		14	14	14	14						
	Q262040	Arandela muelle A-6		14	14	14	14						

MOD.		LAVAVAJILLAS ARRASTRE COMPACTO		ZONA		TUNEL DE LAVADO Y ACLARADO				PLANO		C-1035	
ITEM	CODIGO	DENOMINACION	TEXTO	FI y ECO -160 IZDA.	FI y ECO -200 IZDA.	FI y ECO -160 DCHA.	FI y ECO -200 DCHA.						NOTAS
	Q162040	Tuerca exagonal M-6		14	14	14	14						
8	Z270301	Tunel de lavado y aclarado		1	1	1	1						
	Q232040	Arandela plana A-6		16	16	16	16						Amarre tunel a cuba
	Q262040	Arandela muelle A-6		16	16	16	16						Amarre tunel a cuba
	Q162040	Tuerca exagonal M-6		16	16	16	16						Amarre tunel a cuba
9	Z270516	Tope puerta		2	2	2	2						
10	Z270515	Amarre resorte puerta		2	2	2	2						
	Q232040	Arandela plana A-6		4	4	4	4						
	Q262030	Arandela muelle A-5		4	4	4	4						
	Q212031	Tuerca sombrerete M-5		4	4	4	4						
11	Z270513	Resorte sujecion puerta		2	2	2	2						
	Q152004	Tornillo aplastado M-5x13		2	2	2	2						
	Q232040	Arandela plana A-6		2	2	2	2						
	Q262030	Arandela muelle A-5		2	2	2	2						
	Q212031	Tuerca sombrerete M-5		2	2	2	2						
12	Q352001	Pasador de aletas Ø 2x15		4	4	4	4						
13	Z270514	Eje resorte		2	2	2	2						
14	Z270511	Soporte resorte puerta		2	2	2	2						
	Q232040	Arandela plana A-6		4	4	4	4						
	Q262030	Arandela muelle A-5		4	4	4	4						
	Q212031	Tuerca sombrerete M-5		4	4	4	4						
15	Z270512	Encaje resorte puerta		4	4	4	4						
16	Z270501	Puerta completa montada		1	1	1	1						
17	Z270531	Sujecion puerta		1	1	1	1						
	Q152047	Tornillo cilindrico con cuello M-5		2	2	2	2						
	Q302022	Arandela plana Ø16xØ6x1,2		2	2	2	2						
	Q262030	Arandela muelle A-5		2	2	2	2						
	Q212031	Tuerca sombrerete M-5		2	2	2	2						
18	Z200550	Asa de puerta		1	1	1	1						

MOD.		LAVAVAJILLAS ARRASTRE COMPACTO		ZONA		TUNEL DE LAVADO Y ACLARADO				PLANO		C-1035	
ITEM	CODIGO	DENOMINACION	TEXTO	FI y ECO -160 IZDA.	FI y ECO -200 IZDA.	FI y ECO -160 DCHA.	FI y ECO -200 DCHA.						NOTAS
	Q308007	Arandela dubo A-5		2	2	2	2						
	Q162030	Tuerca exagonal M-5		2	2	2	2						
19	Z200506	Iman puerta		1	1	1	1						
20	Z270336	Guia puerta		2	2	2	2						
	Q152045	Tornillo amarre M-6x25		8	8	8	8						
	Q232040	Arandela plana A-6		8	8	8	8						
	Q222012	Tuerca autoblocante M-6		8	8	8	8						
21	Z270327	Apoyo cortina		1	1	1	1						
	Q232040	Arandela plana A-6		3	3	3	3						
	Q262030	Arandela muelle A-5		3	3	3	3						
	Q212031	Tuerca sombrerete M-5		3	3	3	3						
22	Z270329	Frontal portico derecho		1	1	1	1						
23	Z272906	Sujecion panel		2	2	2	2						
	Q232040	Arandela plana A-6		4	4	4	4						
	Q262030	Arandela muelle A-5		4	4	4	4						
	Q162030	Tuerca exagonal M-5		4	4	4	4						
24	Z272936	Panel lateral		1	1	1	1						
	Q221342	Remache exagonal M-5		2	2	2	2						
	Q232040	Arandela plana A-6		2	2	2	2						
	Q262030	Arandela muelle A-5		2	2	2	2						
	Q152004	Tornillo aplastado M-5x13		2	2	2	2						
25	Z270328	Frontal portico izquierdo		1	1	1	1						
	Q232040	Arandela plana A-6		2	2	2	2						
	Q262030	Arandela muelle A-5		2	2	2	2						
	Q222017	Tuerca sombrerete M-5		2	2	2	2						
26	Z272933	Panel frontal		1	1	1	1						
	Q232040	Arandela plana A-6		3	3	3	3						
	Q262030	Arandela muelle A-5		3	3	3	3						
	Q152004	Tornillo aplastado M-5x13		3	3	3	3						

MOD.		LAVAVAJILLAS ARRASTRE COMPACTO		ZONA		TUNEL DE LAVADO Y ACLARADO				PLANO		C-1035	
ITEM	CODIGO	DENOMINACION	TEXTO	FI y ECO -160 IZDA.	FI y ECO -200 IZDA.	FI y ECO -160 DCHA.	FI y ECO -200 DCHA.						NOTAS
27	Z100522	Interruptor magnetico (puerta)		1	1	1	1						
	Q242020	Arandela abanico A-4		2	2	2	2						
	Q162020	Tuerca exagonal M-4		2	2	2	2						
28	Z270334	Perfil junta entre tunel y cuba		4	4	4	4						
29	Z275057	Uña arrastre derecha		9	9	9	9						
30	Z275056	Uña arrastre izquierda		9	9	9	9						
	Q152046	Tornillo exagonal c/cuello M-6		18	18	18	18						
	Q232050	Arandela plana A-8		36	36	36	36						
	Q262040	Arandela muelle A-6		18	18	18	18						
	Q222012	Tuerca autoblocante M-6		18	18	18	18						
31	Z275051	Soporte uñas lavado y aclarado		1	1	1	1						
	Q012042	Tornillo exagonal M-6x15		2	2	2	2						
	Q232040	Arandela plana A-6		4	4	4	4						
	Q262040	Arandela muelle A-6		2	2	2	2						
	Q222012	Tuerca autoblocante M-6		2	2	2	2						
32	Z275031	Guia lavado anterior (Izda.-Dcha.)		1	1	-	-						Entrada izquierda
s/n	Z275061	Guia lavado anterior (Dcha.-Izda.)		-	-	1	1						Entrada derecha
	Q012042	Tornillo exagonal M-6x15		2	2	2	2						
	Q262040	Arandela muelle A-6		2	2	2	2						
	Z310341	Arandela rectangular		2	2	2	2						
	Q162040	Tuerca exagonal M-6		2	2	2	2						
	Q232040	Arandela plana A-6		4	4	4	4						
	Q262030	Arandela muelle A-5		4	4	4	4						
	Q212031	Tuerca sombrerete M-5		4	4	4	4						
33	Z271211	'U' soporte pulsadores		3	3	3	3						
	Q232040	Arandela plana A-6		6	6	6	6						
	Q262030	Arandela muelle A-5		6	6	6	6						
	Q222017	Tuerca sombrerete M-5		6	6	6	6						
34	Z271204	Muelle torsion derecho		1	1	-	-						Entrada izquierda

MOD.		LAVAVAJILLAS ARRASTRE COMPACTO		ZONA		TUNEL DE LAVADO Y ACLARADO				PLANO		C-1035	
ITEM	CODIGO	DENOMINACION	TEXTO	FI y ECO -160 IZDA.	FI y ECO -200 IZDA.	FI y ECO -160 DCHA.	FI y ECO -200 DCHA.						NOTAS
s/n	Z271203	Muelle torsion izquierdo		-	-	1	1						Entrada derecha
35	Z271205	Pulsador aclarado (Izda.-Dcha.)		1	1	-	-						Entrada izquierda
s/n	Z271222	Pulsador aclarado (Dcha.-Izda.)		-	-	1	1						Entrada derecha
36	Z271201	Soporte pulsador		4	4	4	4						
	Q232040	Arandela plana A-6		8	8	8	8						
	Q262030	Arandela muelle A-5		8	8	8	8						
	Q222017	Tuerca sombrerete M-5		8	8	8	8						
37	Z100522	Interruptor magnetico (aclarado)		1	1	1	1						
	Q242020	Arandela abanico A-4		2	2	2	2						
	Q162020	Tuerca exagonal M-4		2	2	2	2						
38	Z271203	Muelle torsion izquierdo		1	1	1	1						
39	Z271233	Pulsador de lavado (Izda.-Dcha.)		1	1	-	-						Entrada izquierda
s/n	Z271231	Pulsador de lavado (Dcha.-Izda.)		-	-	1	1						Entrada derecha
40	Z271204	Muelle torsion derecho		1	1	1	1						
41	Z100522	Interruptor magnetico (lavado)		1	1	1	1						
	Q242020	Arandela abanico A-4		2	2	2	2						
	Q162020	Tuerca exagonal M-4		2	2	2	2						
42	Z271207	Iman pulsador		2	2	2	2						
	Q072033	Tornillo g.s. M-5x20		2	2	2	2						
	Q232030	Arandela plana A-5		2	2	2	2						
	Q222017	Tuerca sombrerete M-5		2	2	2	2						
43	Z271206	Soporte iman		2	2	2	2						
	Q162040	Tuerca exagonal M-6		4	4	4	4						
44	Z271213	Escuadra soporte pulsador		1	1	1	1						
	Q152004	Tornillo aplastado M-5x13		2	2	2	2						
	Q232040	Arandela plana A-6		2	2	2	2						
	Q262030	Arandela muelle A-5		2	2	2	2						
	Q222017	Tuerca sombrerete M-5		2	2	2	2						
45	Z275075	Deslizamiento guias		4	4	4	4						

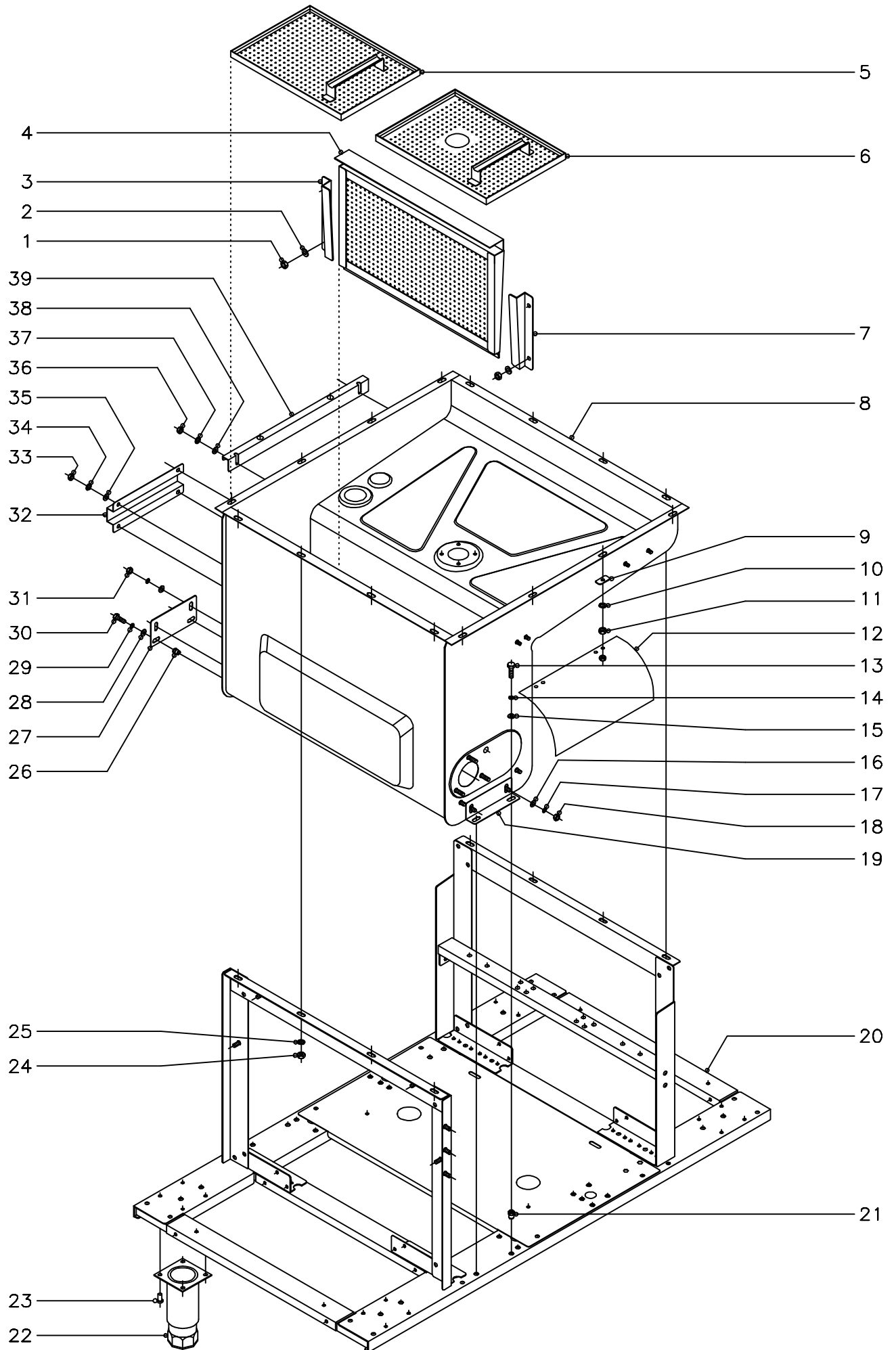

MOD.		LAVAVAJILLAS ARRASTRE COMPACTO		ZONA		ARMAZON Y CUBA						PLANO		C-1036
ITEM	CODIGO	DENOMINACION	TEXTO	FI y ECO -160	FI y ECO -200								NOTAS	
1	Q162040	Tuerca exagonal M-6		4	4									
2	Q262040	Arandela muelle A-6		4	4									
3	Z710310	Guia filtro izquierda		1	1									
4	Z710907	Filtro de aspiracion		1	1									
5	Z270803	Bandeja-filtro posterior		1	1									
6	Z270801	Bandeja-filtro anterior		1	1									
7	Z710309	Guia filtro derecha		1	1									
8	Z270320	Cuba		1	1									
9	Z310341	Arandela rectangular		12	12									
10	Q262040	Arandela muelle A-6		12	12									
11	Q162040	Tuerca exagonal M-6		12	12									
12	Z313041	Cubierta componentes		2	2									
	Q162040	Tuerca exagonal M-6		4	4									
13	Q012042	Tornillo exagonal M-6x15		2	2									
14	Q262040	Arandela muelle A-6		2	2									
15	Q232040	Arandela plana A-6		2	2									
16	Q232040	Arandela plana A-6		2	2									
17	Q262040	Arandela muelle A-6		2	2									
18	Q162040	Tuerca exagonal M-6		2	2									
19	Z270324	Amarre cuba anterior		1	1									
20	Z270101	Armazon montado		1	1									
21	Q221343	Remache exagonal M-6		2	2									
22	X260150	Pata regulable		4	4									
23	Q411304	Remache avibulb Ø 4,8		16	16									
24	Q162040	Tuerca exagonal M-6		4	4									
25	Q262040	Arandela muelle A-6		4	4									
26	Q221343	Remache exagonal M-6		2	2									
27	Z270325	Amarre cuba posterior		1	1									
28	Q232040	Arandela plana A-6		4	4									

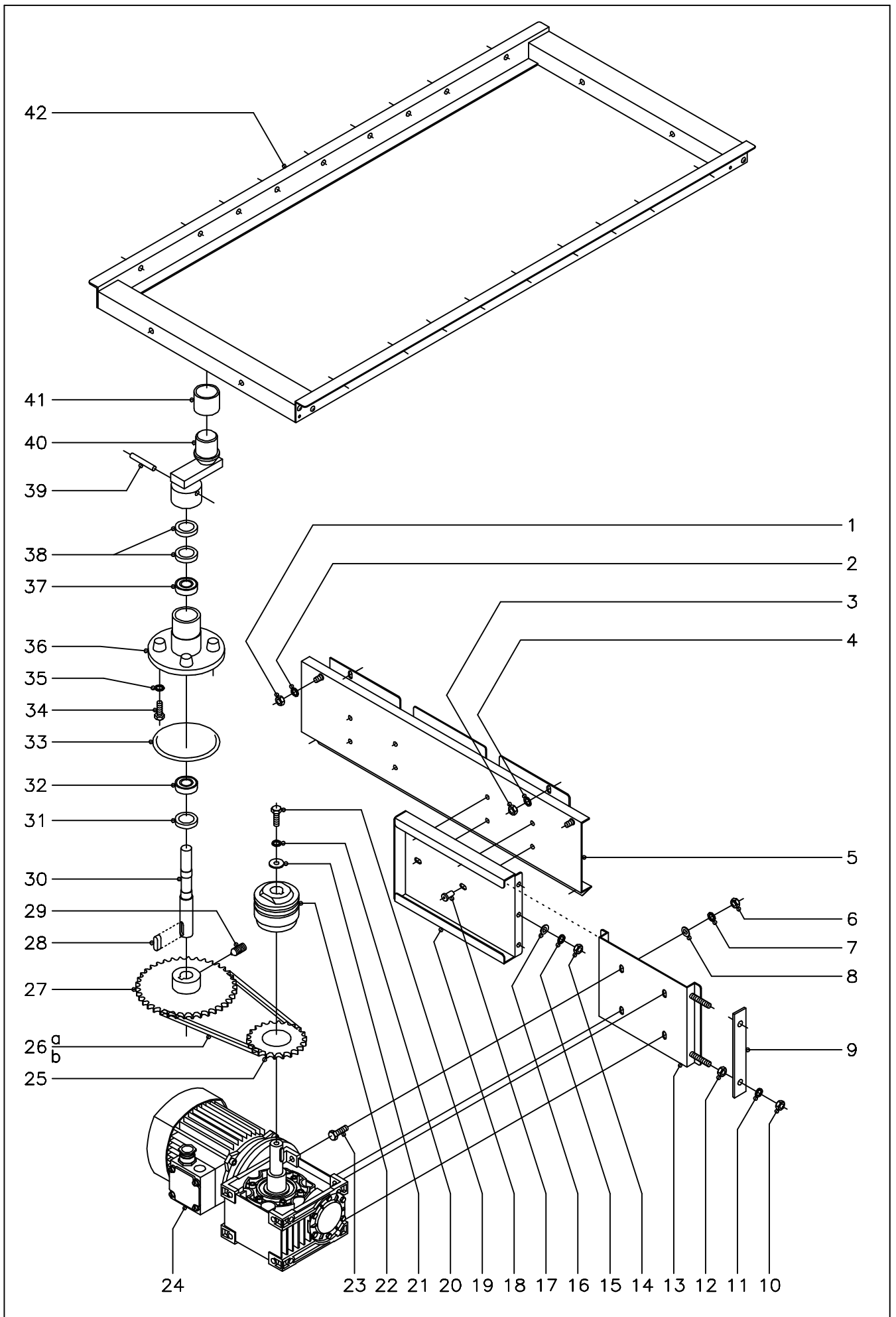

N plano C-1037	Firma 	Fecha 5-2001	Aparato LAVAVAJILLAS ARRASTRE COMPACTO SISTEMA DE ARRASTRE	Lamina 3	Fagor Industrial S.Coop. FAGOR  Oñate
--------------------------	--	------------------------	---	--------------------	--

MOD.		LAVAVAJILLAS ARRASTRE COMPACTO		ZONA	SISTEMA DE ARRASTRE							PLANO	C-1037
ITEM	CODIGO	DENOMINACION	TEXTO	FI y ECO -160	FI y ECO -200							NOTAS	
1	Q162040	Tuerca exagonal M-6		2	2								
2	Q262040	Arandela muelle A-6		2	2								
3	Q162040	Tuerca exagonal M-6		4	4								
4	Q262040	Arandela muelle A-6		4	4								
5	Z270113	Soporte transversal		1	1								
6	Q162050	Tuerca exagonal M-8		4	4								
7	Q262050	Arandela muelle A-8		4	4								
8	Q232050	Arandela plana A-8		4	4								
9	Z275006	Tensor		1	1								
10	Q162050	Tuerca exagonal M-8		2	2								
11	Q262050	Arandela muelle A-8		2	2								
12	Q162050	Tuerca exagonal M-8		2	2								
13	Z275002	Soporte motorreductor		1	1								
14	Q162040	Tuerca exagonal M-6		3	3								
15	Q262040	Arandela muelle A-6		3	3								
16	Q232040	Arandela plana A-6		3	3								
17	Q411304	Remache avibulb Ø 4,8		4	4								
18	Z275005	Guia motorreductor		1	1								
19	Q012053	Tornillo exagonal M-8x20		1	1								
20	Z105010	Arandela plana Ø38xØ10x3		1	1								
21	Z105008	Limitador de par LS-70		1	1								
22	Q012053	Tornillo exagonal M-8x20		4	4								
23	Z275074	Motorreductor de arrastre		1	-							(220-240//250-280V.) (380-420//440-480V.) 50/60Hz.1 velocidad	
23	Z295004	Motorreductor de arrastre		-	1							(220-240//250-280V.) (380-420//440-480V.) 50/60Hz.2 velocidad.	
24	Z105009	Corona Z=22		1	1								
25a	Z275008	Cadena Iris 12,7x7,95x730		1	1								
25b	Z105012	Enganche cadena		1	1								
26	Z275007	Piñon Z=26		1	-								
26	Z105013	Piñon Z=35		-	1								

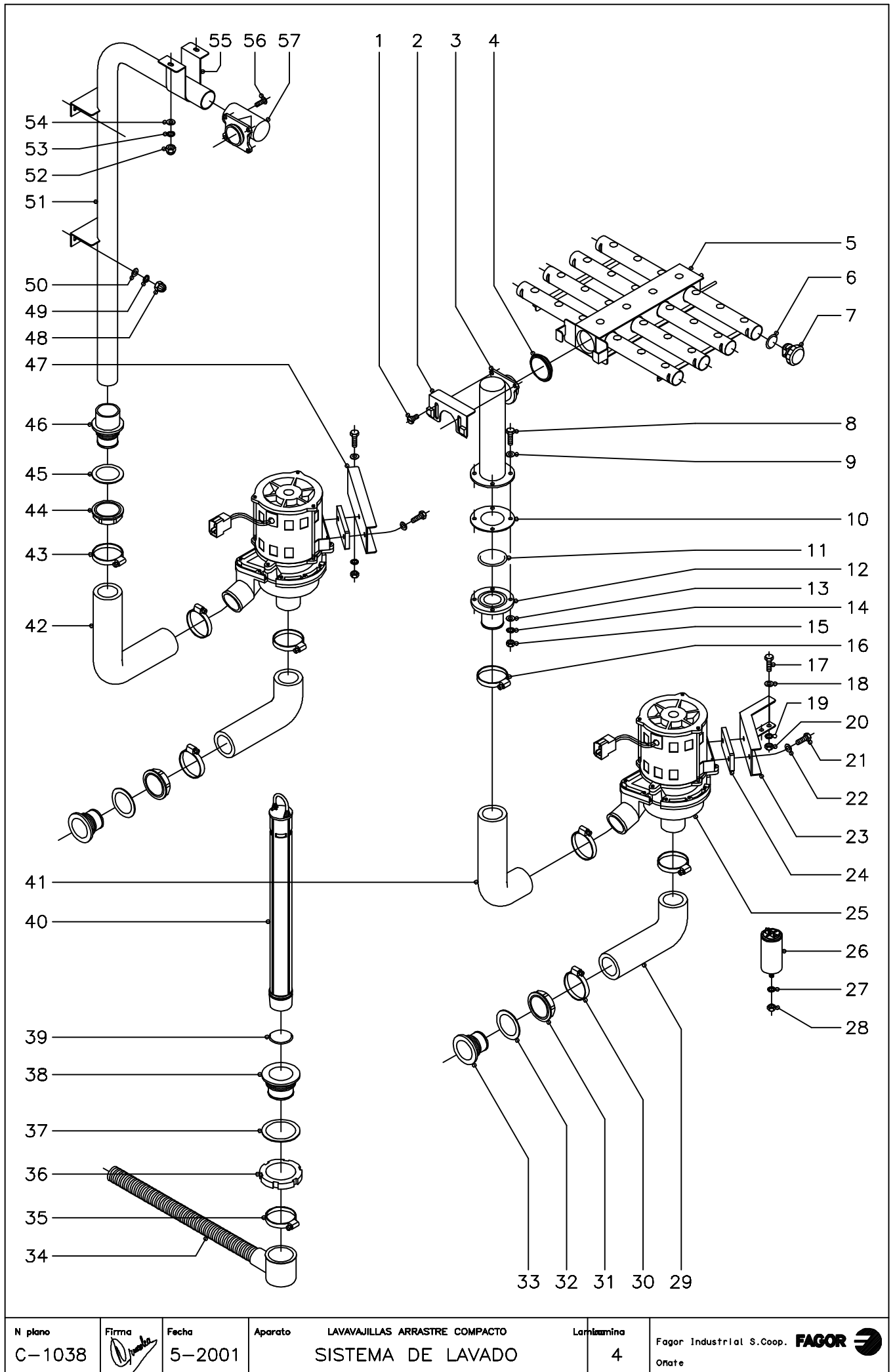

N plano C-1038	Firma 	Fecha 5-2001	Aparato LAVAVAJILLAS ARRASTRE COMPACTO SISTEMA DE LAVADO	Laminamina 4	Fagor Industrial S.Coop. FAGOR Ofate
-------------------	-----------	-----------------	--	-----------------	--

MOD.		LAVAVAJILLAS ARRASTRE COMPACTO		ZONA	SISTEMA DE LAVADO							PLANO	C-1038
ITEM	CODIGO	DENOMINACION	TEXTO	FI y ECO -160	FI y ECO -200								NOTAS
1	Q152047	Tornillo cilindrico c/cuello M-5		4	4								
2	Z270722	Amarre distribuidor		2	2								
3	Z270711	Soporte distribuidor inferior		1	1								
4	Z270731	Junta de estanqueidad		2	2								
5	Z270714	Distribuidor de agua		2	2								
6	Q307062	Junta torica Ø23,47xØ28,71xØ2,62		16	16								
7	Z270721	Tapon cierre distribuidor		16	16								
8	Q012044	Tornillo exagonal M-6x25		4	4								
9	Q306050	Arandela fibra Ø11xØ6,2x1,5		4	4								
10	Z710714	Junta de goma Ø83xØ44x2		1	1								
11	Q307057	Junta torica Ø54,28xØ47,22xØ3,53		1	1								
12	Z270701	Pasamuros inferior		1	1								
13	Q232040	Arandela plana A-6		4	4								
14	Q262040	Arandela muelle A-6		4	4								
15	Q162040	Tuerca exagonal M-6		4	4								
16	Q881307	Abrazadera 40 - 60		2	2								
17	Q012042	Tornillo exagonal M-6x15		4	4								
18	Q232040	Arandela plana A-6		4	4								
19	Q262040	Arandela muelle A-6		4	4								
20	Q162040	Tuerca exagonal M-6		4	4								
21	Q012042	Tornillo exagonal M-6x15		4	4								
22	Q232040	Arandela plana A-6		4	4								
23	Z711001	Soporte motobomba anterior		1	1								
24	Z201003	Base motobomba lavado		2	2								
25	Z201011	Bomba de lavado		2	2								
26	V321300	Condensador 10 M.F.		2	2								
27	Q262050	Arandela muelle A-8		2	2								
28	Q162050	Tuerca exagonal M-8		2	2								
29	Z710904	Conducto aspiracion		2	2								

MOD.		LAVAVAJILLAS ARRASTRE COMPACTO		ZONA	SISTEMA DE LAVADO							PLANO	C-1038
ITEM	CODIGO	DENOMINACION	TEXTO	FI y ECO -160	FI y ECO -200								NOTAS
30	Q881307	Abrazadera 40 - 60		4	4								
31	Z710708	Tuerca pasamuros		2	2								
32	Q307058	Arandela junta Ø60xØ44x2		2	2								
33	Z710903	Pasamuros aspiracion		2	2								
34	Z200910	Manguera desagüe		1	1								
35	Q881307	Abrazadera 40 - 60		1	1								
36	Q220001	Tuerca ranurada M-56x2,5		1	1								
37	Q307059	Arandela junta Ø72xØ56x2		1	1								
38	Z710902	Pasamuros desagüe		1	1								
39	Q307051	Junta torica Ø41,41xØ36,17xØ2,62		1	1								
40	Z270901	Aliviadero de nivel		1	1								
41	Z710905	Conducto impulsión anterior		1	1								
42	Z710906	Conducto impulsión posterior		1	1								
43	Q881307	Abrazadera 40 - 60		2	2								
44	Z710708	Tuerca pasamuros		1	1								
45	Q307058	Arandela junta Ø60xØ44x2		1	1								
46	Z330751	Pasamuros		1	1								
47	Z711002	Soporte motobomba posterior		1	1								
48	Q212031	Tuerca sombrerete M-5		4	4								
49	Q262030	Arandela muelle A-5		4	4								
50	Q232040	Arandela plana A-6		4	4								
51	Z270703	Arbol de lavado		1	1								
52	Q212031	Tuerca sombrerete M-5		2	2								
53	Q262030	Arandela muelle A-5		2	2								
54	Q232040	Arandela plana A-6		2	2								
55	Z270706	Sujeción arbol lavado		1	1								
56	Q152004	Tornillo aplastado M-5x13		1	1								
57	Z270712	Soporte distribuidor superior		1	1								

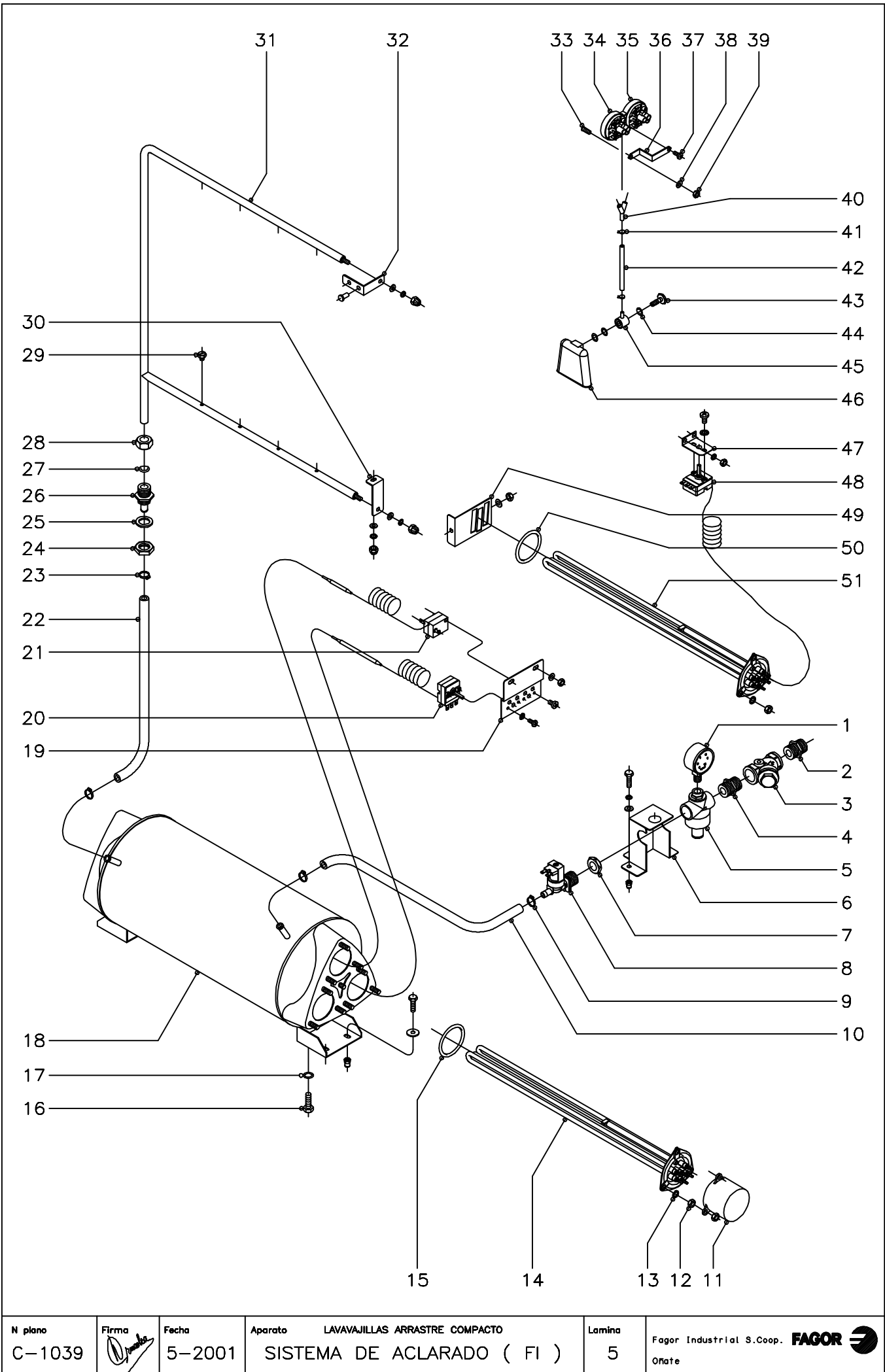

N plano C-1039	Firma 	Fecha 5-2001	Aparato LAVAVAJILLAS ARRASTRE COMPACTO SISTEMA DE ACLARADO (FI)	Lamina 5	Fagor Industrial S.Coop. FAGOR  Orate
-------------------	--	-----------------	---	-------------	--

MOD.		LAVAVAJILLAS ARRASTRE COMPACTO		ZONA		SISTEMA DE ACLARADO (FI)						PLANO		C-1039
ITEM	CODIGO	DENOMINACION	TEXTO	FI -160	FI -200									NOTAS
1	Z102316	Manometro		1	1									
2	Z102301	Manguito 3/4"		1	1									
3	Z102308	Filtro 3/4"		1	1									
4	Z102301	Manguito 3/4"		1	1									
5	Z102307	Reductor de presion		1	1									
6	Z271120	Soporte conduccion		1	1									
	Q012042	Tornillo exagonal M-6x15		3	3									
	Q262040	Arandela muelle A-6		3	3									
	Q232040	Arandela plana A-6		3	3									
	Q221343	Remache exagonal M-6		3	3									
7	Q221324	Tuerca exagonal 3/4"		1	1									
8	Z701135	Electrovalvula simple		1	1									
9	Q881302	Abrazadera 12 - 20		2	2									
10	3676900	Tubo goma Ø 17xØ 10x800		1	1									
11	Z101723	Caperuza resistencias		3	3									
12	Q163140	Tuerca exagonal M-6		18	18									
13	Q262040	Arandela muelle A-6		9	9									
14	Z121741	Resistencia 9600 W., 230 V.		3	3									
14	Z129502	Resistencia 11500 W., 230 V.		3	3									
15	Q307044	Junta torica Ø67,18xØ56,52xØ5,30		3	3									
16	Q012063	Tornillo exagonal M-10x20		1	1									Tapon desagüe
17	Q307048	Junta torica Ø16,18xØ9,12xØ3,53		1	1									Tapon desagüe
18	Z311701	Cuerpo calderin		1	1									
	Q012042	Tornillo exagonal M-6x15		4	4									
	Q301304	Arandela plana Ø23xØ6,5x2		4	4									
	Q221343	Remache exagonal M-6		4	4									
19	Z403005	Soporte termostatos		1	1									
	Q232040	Arandela plana A-6		2	2									
	Q162040	Tuerca exagonal M-6		2	2									

MOD.		LAVAVAJILLAS ARRASTRE COMPACTO		ZONA	SISTEMA DE ACLARADO (FI)						PLANO	C-1039
ITEM	CODIGO	DENOMINACION	TEXTO	FI -160	FI -200							NOTAS
20	Z203014	Termostato		1	1							
	Q242020	Arandela abanico A-4		2	2							
	Q152024	Tornillo avellanado M-4x8		2	2							
21	Z213014	Termostato limitador calderin		1	1							
	Q081330	Tornillo alomado BZ-3,5x6,5		2	2							
22	3676900	Tubo de goma Ø17xØ10x400		1	1							Para entrada izquierda
22	3676900	Tubo de goma Ø17xØ10x600		1	1							Para entrada derecha
23	Q881302	Abrazadera 12 - 20		2	2							
24	Q223023	Tuerca exagonal 5/8"		1	1							
25	Q307032	Arandela junta Ø32xØ21x3		1	1							
26	Z271901	Pasamuros aclarado		1	1							
27	Q307063	Junta torica Ø19,35xØ12,29xØ3,53		1	1							
28	Q223108	Tuerca amarre M-24x2,5		1	1							
29	Z211903	Tobera de aclarado		8	8							
30	Z271912	Amarre inferior aclarado		1	1							
	Q232040	Arandela plana A-6		1	1							
	Q262030	Arandela muelle A-5		1	1							
	Q212031	Tuerca sombrerete M-5		1	1							
31	Z271902	Arbol de aclarado		1	1							
	Q232040	Arandela plana A-6		2	2							
	Q262030	Arandela muelle A-5		2	2							
	Q212031	Tuerca sombrerete M-5		2	2							
32	Z271911	Soporte superior aclarado		1	1							
	Q412004	Remache monobolt Ø4,8		2	2							
33	-	Perno soldado a maquina M-6		1	1							
34	Z103074	Presostato simple nivel bajo		1	1							
35	Z273006	Presostato simple nivel alto		1	1							
36	Z602923	Soporte presostato		1	1							
37	Q082032	Tornillo alomado BZ-3,5x9,5		1	1							

MOD.		LAVAVAJILLAS ARRASTRE COMPACTO		ZONA	SISTEMA DE ACLARADO (FI)						PLANO	C-1039
ITEM	CODIGO	DENOMINACION	TEXTO	FI -160	FI -200							NOTAS
38	Q232040	Arandela plana A-6		1	1							
39	Q162040	Tuerca exagonal M-6		1	1							
40	Z103077	Racord en " Y "		1	1							
41	P102154	Brida elastica p/tubo		2	2							
42	3702400	Tubo de goma Ø8xØ4x100		1	1							
43	Z203013	Tornillo presostato		1	1							
44	Q307003	Junta torica Ø16,01xØ10,77xØ2,62		3	3							
45	Z203012	Empalme presostato		1	1							
46	Z203011	Camara presostato		1	1							
47	Z850111	Soporte termostato		1	1							Tanque de lavado
	Q232040	Arandela plana A-6		2	2							Tanque de lavado
	Q162040	Tuerca exagonal M-6		2	2							Tanque de lavado
48	Z203014	Termostato		1	1							Tanque de lavado
	Q242020	Arandela abanico A-4		2	2							Tanque de lavado
	Q152024	Tornillo avellanado M-4x8		2	2							Tanque de lavado
49	Z273602	Sujecion resistencia tanque		1	1							Tanque de lavado
	Q232040	Arandela plana A-6		1	1							Tanque de lavado
	Q162040	Tuerca exagonal M-6		1	1							Tanque de lavado
50	Q307044	Junta torica Ø67,18xØ56,52xØ5,30		1	1							Tanque de lavado
51	Z121741	Resistencia 9600 W., 230 V.		1	1							Tanque de lavado
	Q262040	Arandela muelle A-6		3	3							Tanque de lavado
	Q163140	Tuerca exagonal M-6		3	3							Tanque de lavado

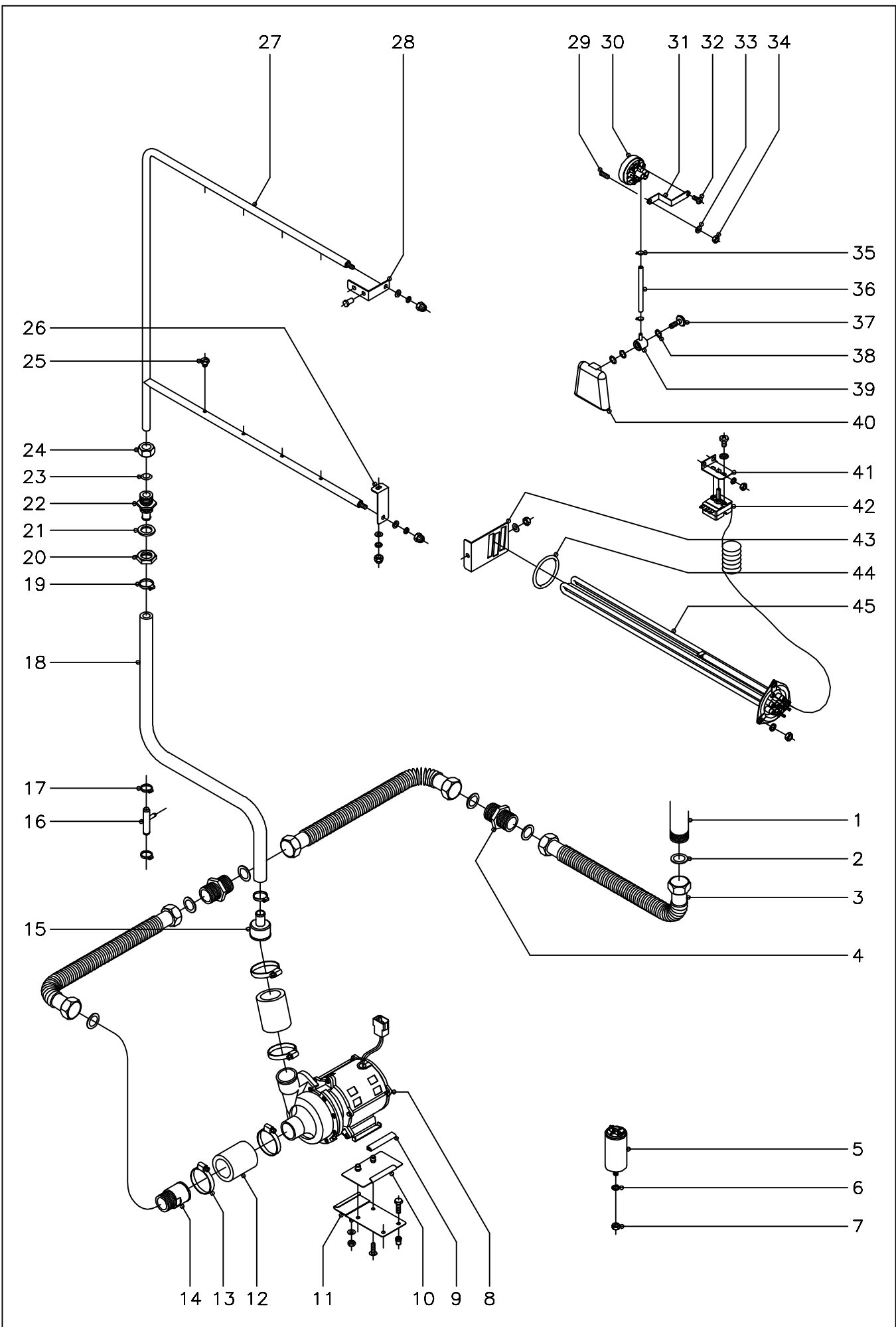

N plano C-1040	Firma 	Fecha 5-2001	Aparato LAVAVAJILLAS ARRASTRE COMPACTO SISTEMA DE ACLARADO (ECO)	Lamina 6	Fagor Industrial S.Coop. FAGOR  Oñate
--------------------------	--	------------------------	---	--------------------	--

MOD.		LAVAVAJILLAS ARRASTRE COMPACTO		ZONA	SISTEMA DE ACLARADO (ECO)						PLANO	C-1040
ITEM	CODIGO	DENOMINACION	TEXTO	ECO -160	ECO -200							NOTAS
1	-	Generador agua caliente GA-40		1	1							
2	Q306038	Arandela junta Ø31xØ21x1,5		6	6							
3	Z951101	Tuberia flexible L=1000		3	3							
4	Z162306	Manguito doble 1"		2	2							
5	V817100	Condensador 6 M.F.		1	1							
6	Q242050	Arandela abanico A-8		1	1							
7	Q162050	Tuerca exagonal M-8		1	1							
8	Z401001	Bomba de aclarado 230 V.		1	1							
9	3701700	Perfil goma negra en "U" L=70		2	2							
10	Z162313	Amarre motobomba		1	1							
	Q152004	Tornillo aplastado M-5x13		2	2							
11	Z162315	Soporte motobomba		1	1							
	Q232040	Arandela plana A-6		1	1							
	Q162040	Tuerca exagonal M-6		1	1							
	Q012042	Tornillo exagonal M-6x15		2	2							
	Q221343	Remache exagonal M-6		2	2							
12	Z162301	Conducto aspiracion - impulsion		2	2							
13	Q881307	Abrazadera 40 - 60		4	4							
14	Z701102	Manguito		1	1							
15	Z162312	Reduccion		1	1							
16	Z601157	Toma presion		1	1							
17	Q881336	Abrazadera 16 - 27		2	2							
18	3715300	Tubo de goma Ø24xØ14x800		1	1							
19	Q881336	Abrazadera 16 - 27		2	2							
20	Q223023	Tuerca exagonal 5/8"		1	1							
21	Q307032	Arandela junta Ø32xØ21x3		1	1							
22	Z281901	Pasamuros aclarado		1	1							
23	Q307063	Junta torica Ø19,35xØ12,29xØ3,53		1	1							
24	Q223108	Tuerca amarre M-24x2,5		1	1							

MOD.		LAVAVAJILLAS ARRASTRE COMPACTO		ZONA	SISTEMA DE ACLARADO (ECO)						PLANO	C-1040	
ITEM	CODIGO	DENOMINACION	TEXTO	ECO -160	ECO -200								NOTAS
25	Z211903	Tobera aclarado		8	8								
26	Z271912	Amarre inferior aclarado		1	1								
	Q232040	Arandela plana A-6		1	1								
	Q262030	Arandela muelle A-5		1	1								
	Q212031	Tuerca sombrerete M-5		1	1								
27	Z271902	Arbol de aclarado		1	1								
	Q232040	Arandela plana A-6		2	2								
	Q262030	Arandela muelle A-5		2	2								
	Q212031	Tuerca sombrerete M-5		2	2								
28	Z271911	Soporte superior aclarado		1	1								
	Q412004	Remache monobolt Ø4,8		2	2								
29	-	Perno soldado a maquina M-6		1	1								
30	Z273006	Presostato simple nivel alto		1	1								
31	Z602923	Soporte presostato		1	1								
32	Q082032	Tornillo alomado BZ-3,5x9,5		1	1								
33	Q232040	Arandela plana A-6		1	1								
34	Q162040	Tuerca exagonal M-6		1	1								
35	P102154	Brida elastica p/tubo		2	2								
36	3702400	Tubo de goma Ø8xØ4x100		1	1								
37	Z203013	Tornillo presostato		1	1								
38	Q307003	Junta torica Ø16,01xØ10,77xØ2,62		3	3								
39	Z203012	Empalme presostato		1	1								
40	Z203011	Camara presostato		1	1								
41	Z850111	Soporte termostato		1	1								Tanque de lavado
	Q232040	Arandela plana A-6		2	2								Tanque de lavado
	Q162040	Tuerca exagonal M-6		2	2								Tanque de lavado
42	Z203014	Termostato		1	1								Tanque de lavado
	Q242020	Arandela abanico A-4		2	2								Tanque de lavado
	Q152024	Tornillo avellanado M-4x8		2	2								Tanque de lavado

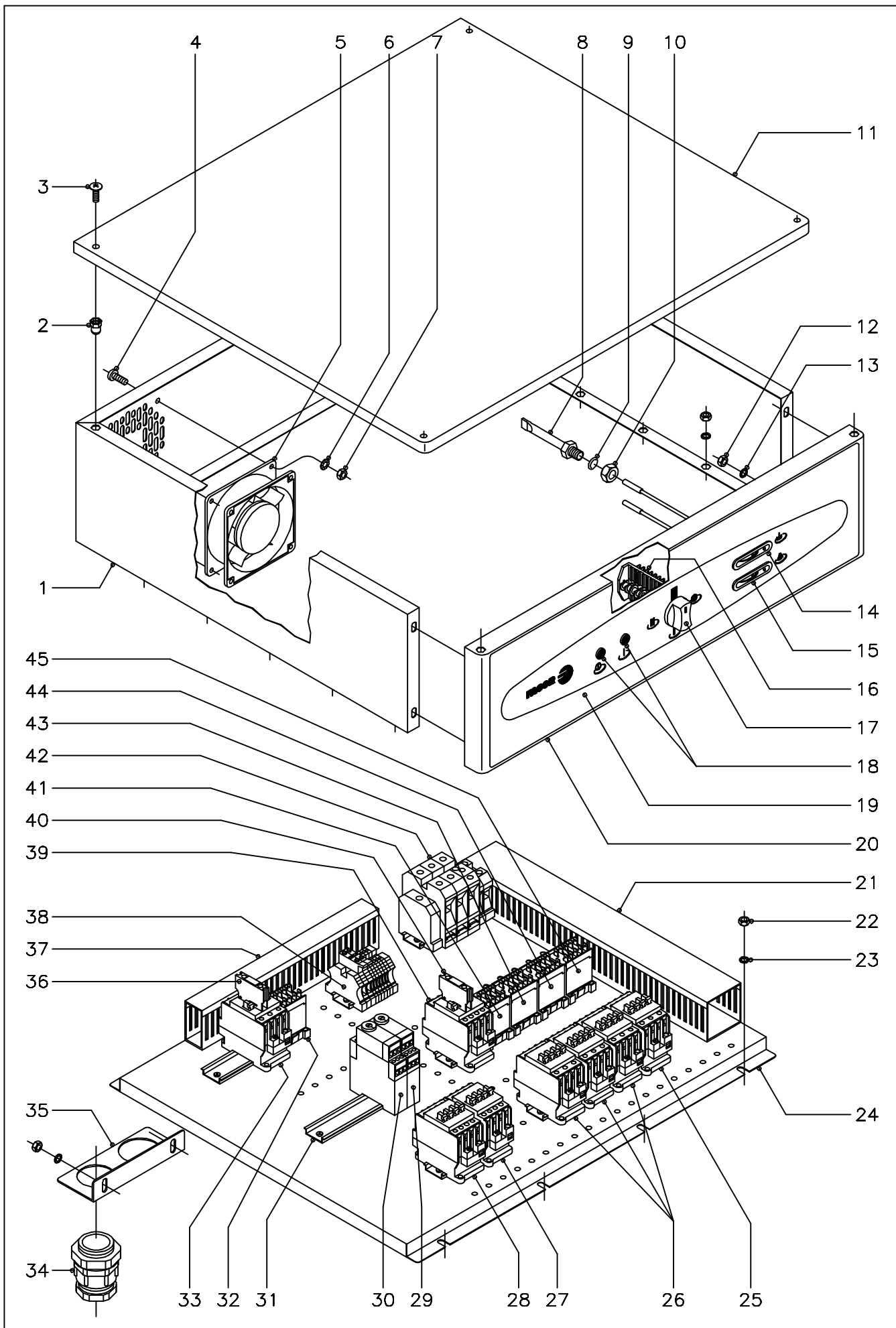

N plano C-1041	Firma 	Fecha 5-2001	Aparato LAVAVAJILLAS ARRASTRE COMPACTO PARTE ELECTRICA	Lamina 7	Fagor Industrial S.Coop. FAGOR Ofate
-------------------	-----------	-----------------	--	-------------	--

MOD.		LAVAVAJILLAS ARRASTRE COMPACTO		ZONA	PARTE ELECTRICA								PLANO	C-1041
ITEM	CODIGO	DENOMINACION	TEXTO	FI -160	FI -200	ECO -160	ECO -200						NOTAS	
1	Z313043	Cubierta cuadro electrico		1	1	1	1							
	Q262040	Arandela muelle A-6		12	12	12	12							
	Q162040	Tuerca exagonal M-6		12	12	12	12							
2	Q221343	Remache exagonal M-6		4	4	4	4							
3	Q152017	Tornillo amarre M-6x13		4	4	4	4							
4	Q031322	Tornillo alomado M-4x15		4	4	4	4							
5	Z103066	Ventilador 230 V., 50/60 Hz.		1	1	1	1							
6	Q242020	Arandela abanico A-4		4	4	4	4							
7	Q162020	Tuerca exagonal M-4		4	4	4	4							
8	Z263002	Vaina para bulbo en cuba lavado		1	1	1	1							
9	Q307048	Junta torica Ø16,18xØ9,12xØ3,53		1	1	1	1							
10	Q162070	Tuerca exagonal M-12		1	1	1	1							
11	Z313048	Tapa cuadro electrico		1	1	1	1							
12	Q162040	Tuerca exagonal M-6		4	4	4	4							
13	Q262040	Arandela muelle A-6		4	4	4	4							
14	Z263001	Indicador analogico (cuba lavado)		1	1	1	1							
15	Z263001	Indicador analogico (Calderin acl.)		1	1	-	-							
16	Z273005	Conmutador de funciones		1	1	1	1							
	Z602906	Casquillo distanciador		2	2	2	2							
	Q041324	Tornillo avellanado M-4x25		2	2	2	2							
17	R663062	Boton de mando completo		1	1	1	1							
18	Z203005	Piloto ambar		2	2	2	2							
19	Z272931	Embellecedor adhesivo FI-160		1	-	-	-							
19	Z312961	Embellecedor adhesivo FI-200		-	1	-	-							
19	Z282911	Embellecedor adhesivo ECO-160		-	-	1	-							
19	Z322902	Embellecedor adhesivo ECO-200		-	-	-	1							
20	Z313045	Frente cuadro electrico		1	1	1	1							
21	3715510	Canaleta unex 60x60x77 L=430		2	2	2	2							
	3715510	Canaleta unex 60x60x77 L=240		2	2	2	2							

MOD.		LAVAVAJILLAS ARRASTRE COMPACTO		ZONA	PARTE ELECTRICA								PLANO	C-1041
ITEM	CODIGO	DENOMINACION	TEXTO	FI -160	FI -200	ECO -160	ECO -200						NOTAS	
22	Q162040	Tuerca exagonal M-6		8	8	8	8							
23	Q262040	Arandela muelle A-6		8	8	8	8							
24	Z313042	Soporte cuadro electrico		1	1	1	1							
25	X183011	Contactador (resistencia tanque)		1	1	1	1							
26	X183011	Contactador (resistencias calderin)		3	3	-	-							
27	R663031	Contactador (extractor o condensador)		1	1	1	1							
28	R663031	Contactador (secado)		1	1	1	1							
29	Z123022	Temporizador (inicio)		1	1	1	1							
30	Z123022	Temporizador (secado)		1	1	1	1							
31	R693009	Guia contactor L=250		2	2	2	2							
	Z123019	Guia contactor L=175		3	3	3	3							
	R663055	Guia contactor L=120		2	2	2	2							
	Q419005	Remache tubular Ø4x8		14	14	14	14							
32	Z213007	Contactador (puerta)		1	1	1	1							
33	X183011	Contactador (resistencias secado)		1	1	1	1							
34	R033002	Prensaestopas		1	1	1	1							
35	Z312966	Soporte prensaestopas		1	1	1	1							
	Q262040	Arandela muelle A-6		2	2	2	2							
	Q162040	Tuerca exagonal M-6		2	2	2	2							
36	Z103070	Contacto auxiliar		1	1	1	1							
37	3715520	Canaleta unex 60x30x77 L=280		1	1	1	1							
	3715520	Canaleta unex 60x30x77 L=520		1	1	1	1							
	3715520	Canaleta unex 60x30x77 L=150		2	2	2	2							
38	R073005	Bornas portafusibles		2	2	2	2							
	P184011	Cartucho fusible 4 A.		2	2	2	2							
	Z103029	Bornes (detergente y tensoactivo)		6	6	6	6							
	Z263303	Tope final		2	2	2	2							
39	R663031	Contactador (llenado y aclarado)		1	1	1	1							
40	Z316328	Contacto auxiliar		1	1	1	1							

MOD.		LAVAVAJILLAS ARRASTRE COMPACTO		ZONA	PARTE ELECTRICA								PLANO	C-1041
ITEM	CODIGO	DENOMINACION	TEXTO	FI -160	FI -200	ECO -160	ECO -200						NOTAS	
41	Z213007	Contactador (bomba lavado)		1	1	1	1							
42	R143011	Borne fases 70 gris		3	3	-	-							
	R263003	Borne fases 35 gris		-	-	3	3							
	R673010	Borne neutro 35 azul		1	1	1	1							
	Z103035	Borne tierra 35 Verde - amarillo		1	1	1	1							
	Z683096	Tope final		1	1	1	1							
43	Z683087	Contactador (aclarado)		1	1	1	1							
44	Z213007	Contactador (avance 1)		1	1	1	1							
45	Z213007	Contactador (avance 2)		-	1	-	1							
s/n	Z273016	Micro fin de carrera		1	1	1	1							
	Z276111	Folleto de instrucciones FI		1	1	-	-							
	Z286110	Folleto de instrucciones ECO		-	-	1	1							
	Z273018	Esquema electrico adhesivo FI		1	1	-	-						Plano HC-17294	
	Z283020	Esquema electrico adhesivo ECO		-	-	1	1						Plano HC-17304	
	Z313070	Leyenda esquemas electricos		1	1	1	1						Plano HC-17259	
	Z273030	Instalacion electrica base		1	1	1	1							
	Z273031	Instalacion electrica calderin		1	1	-	-							
	Z273032	Instalacion electrica velocidad II		-	1	-	1							

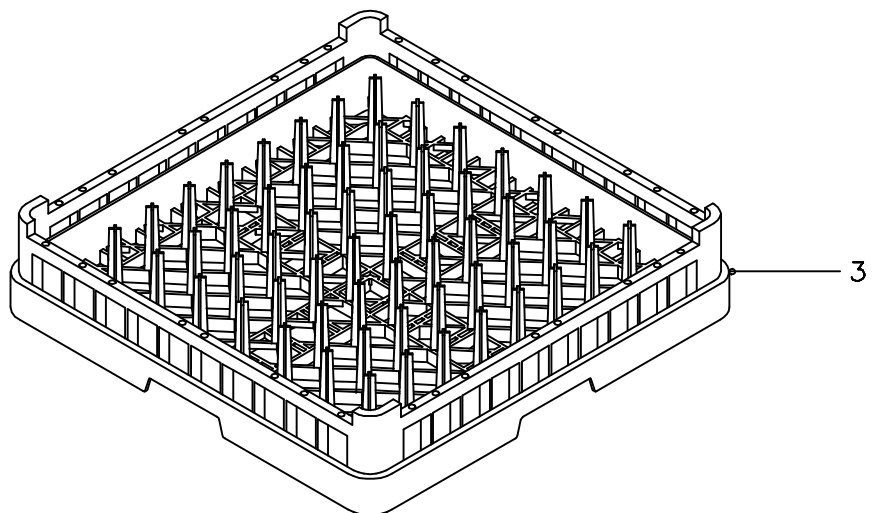
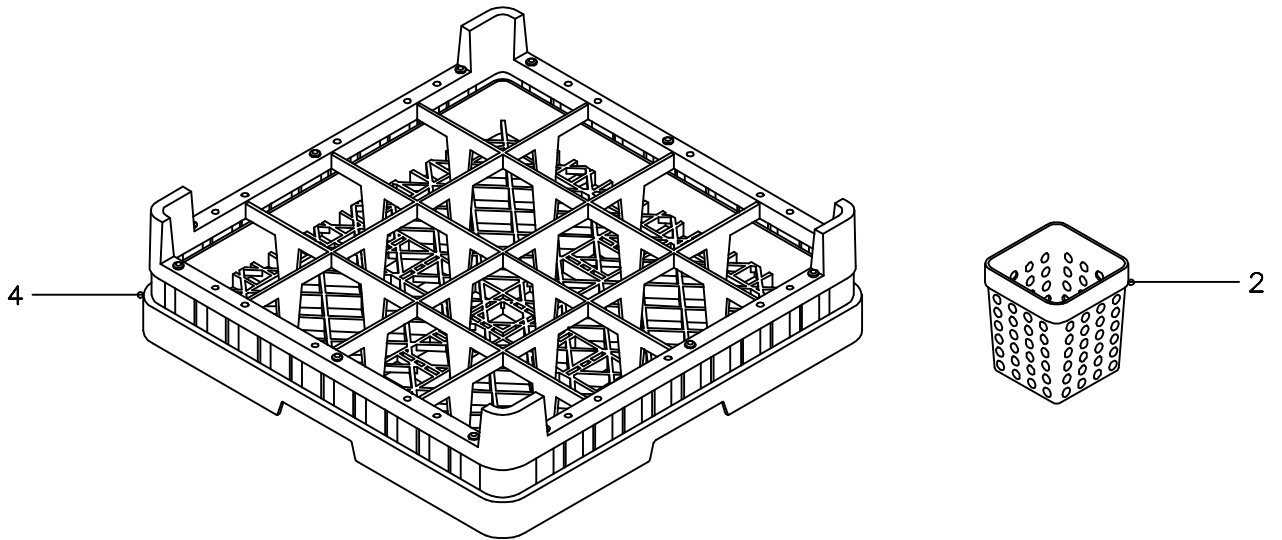
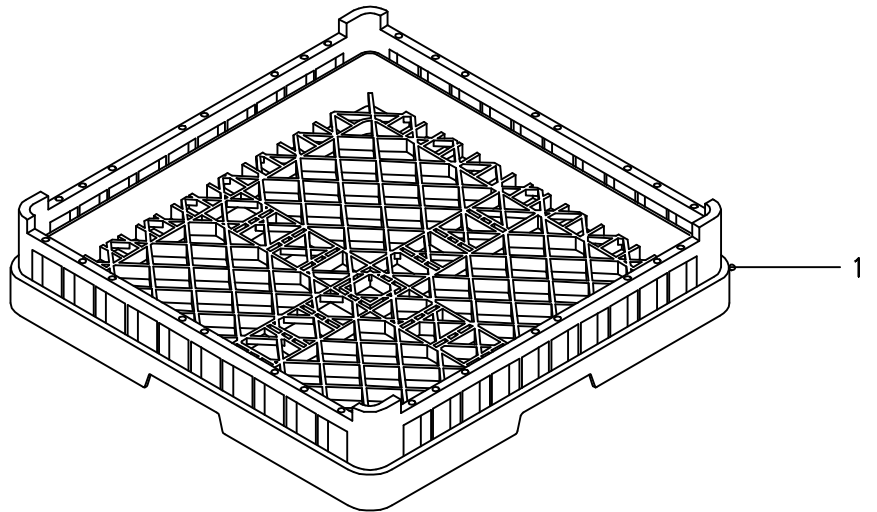

N plano C-1042	Firma 	Fecha 5-2001	Aparato LAVAVAJILLAS ARRASTRE COMPACTO CESTILLOS	Lamina 8	Fagor Industrial S.Coop. FAGOR  Oñate
--------------------------	--	------------------------	--	--------------------	--

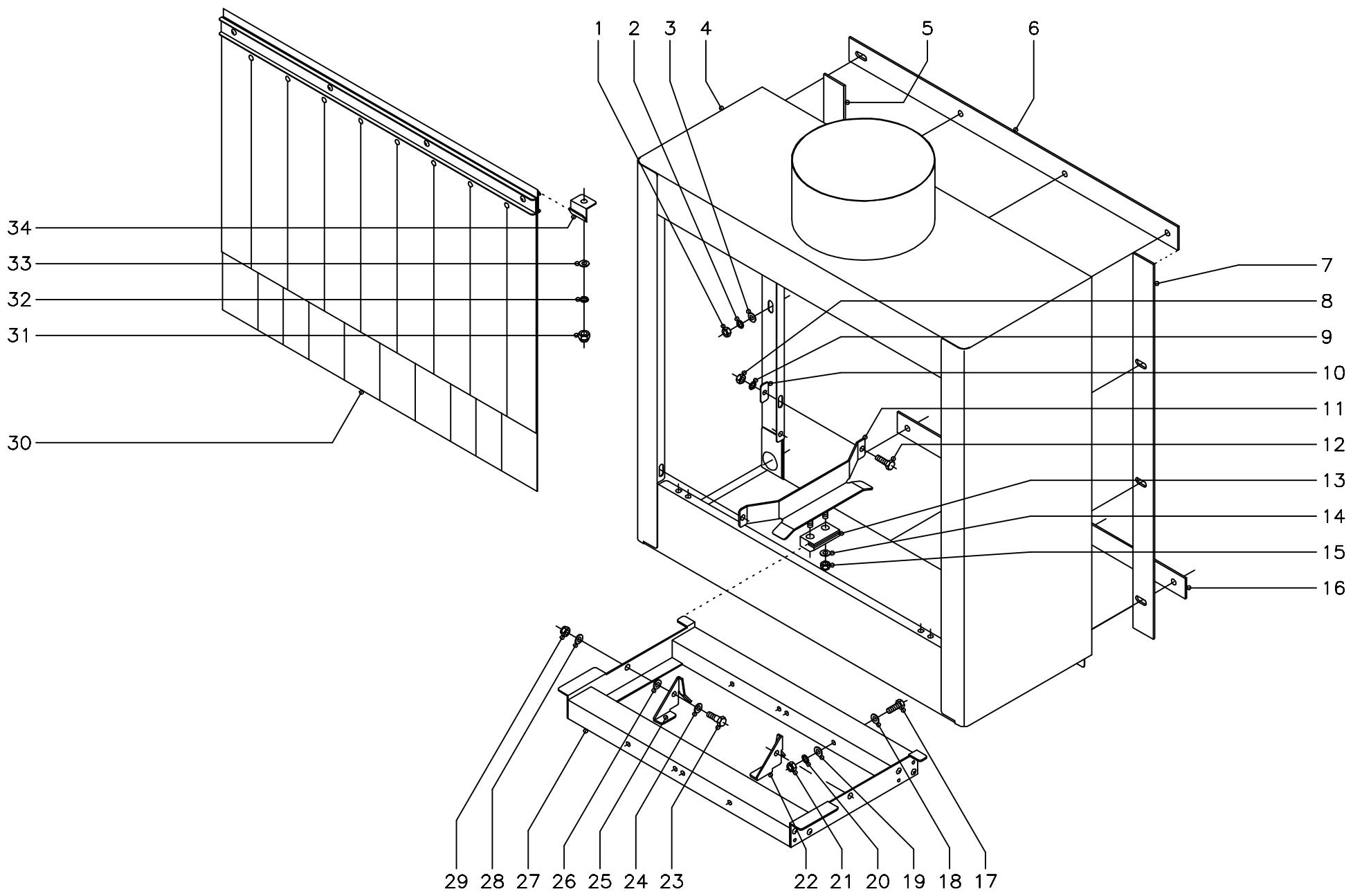

MOD.		LAVAVAJILLAS ARRASTRE COMPACTO		ZONA		TUNEL ASPIRADOR VAHOS						PLANO		C-1043	
ITEM	CODIGO	DENOMINACION	TEXTO	FI y ECO -160	FI y ECO -200									NOTAS	
1	Q162040	Tuerca exagonal M-6		12	12										
2	Q262040	Arandela muelle A-6		12	12										
3	Q302022	Arandela plana Ø 16xØ 6x1,2		12	12										
4	Z276501	Tunel aspirador de vahos		1	1										
5	Z330442	Perfil junta posterior		1	1										
6	Z330443	Perfil junta superior		1	1										
7	Z330441	Perfil junta anterior		1	1										
8	Q162040	Tuerca exagonal M-6		4	4										
9	Q262040	Arandela muelle A-6		4	4										
10	Z310341	Arandela rectangular		4	4										
11	Z276211	Guia entrada-salida		2	2										
12	Q012042	Tornillo exagonal M-6x15		4	4										
13	Z275075	Deslizamiento guias		2	2										
14	Q232040	Arandela plana A-6		4	4										
15	Q222012	Tuerca autoblocante M-6		4	4										
16	Z330444	Perfil junta inferior		1	1										
17	Q012042	Tornillo exagonal M-6x15		2	2										
18	Q232050	Arandela plana A-8		2	2										
19	Q232050	Arandela plana A-8		2	2										
20	Q262040	Arandela muelle A-6		2	2										
21	Q222012	Tuerca autoblocante M-6		2	2										
22	Z275056	Uña arrastre izquierdo		1	1										
23	Q152046	Tornillo exagonal con cuello M-6		2	2										
24	Q232050	Arandela plana A-8		2	2										
25	Z275057	Uña arrastre derecha		1	1										
26	Q232050	Arandela plana A-8		2	2										
27	Z276221	Soporte uñas entrada		1	1										
28	Q232040	Arandela plana A-6		2	2										
29	Q222012	Tuerca autoblocante M-6		2	2										

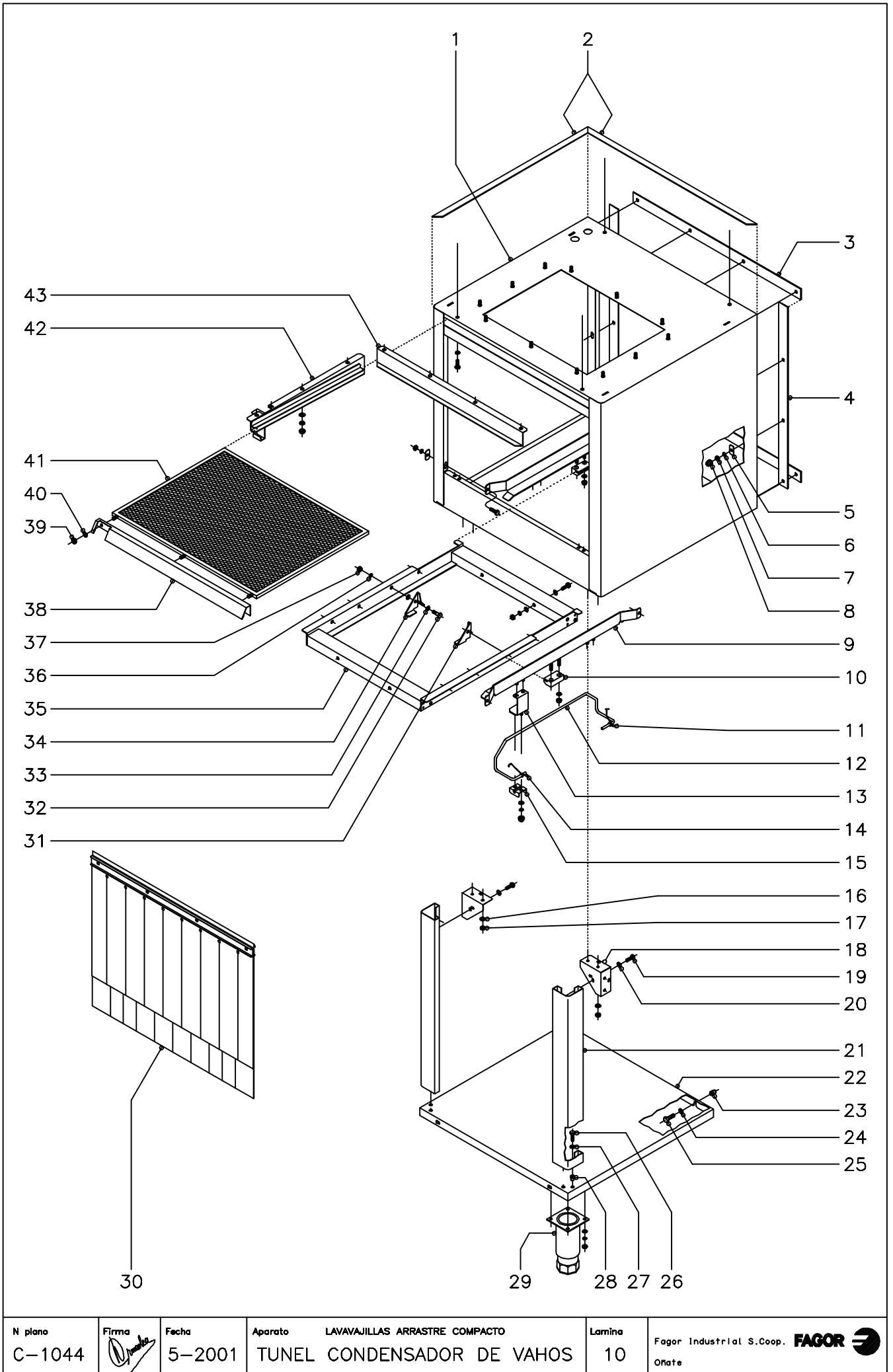

N plano C-1044	Firma 	Fecha 5-2001	Aparato LAVAVAJILLAS ARRASTRE COMPACTO TUNEL CONDENSADOR DE VAHOS	Lamina 10	Fagor Industrial S.Coop. FAGOR  Ofite
-------------------	--	-----------------	---	--------------	--

MOD.		LAVAVAJILLAS ARRASTRE COMPACTO		ZONA	TUNEL CONDENSADOR DE VAHOS						PLANO	C-1044
ITEM	CODIGO	DENOMINACION	TEXTO	TUNEL CONDENSADOR								NOTAS
1	Z276701	Tunel condensador vahos		1								
	Q262040	Arandela muelle A-6		4								
	Q012042	Tornillo exagonal M-6x15		4								
2	Z270334	Perfil junta autoadhesiva		4								
3	Z276204	Junta superior e inferior		2								
4	Z276205	Junta lateral		2								
5	Z310341	Arandela rectangular		14								
6	Q262040	Arandela muelle A-6		14								
7	Q162040	Tuerca exagonal M-6		14								
8	Q212040	Tuerca sombrerete M-6		14								
9	Z276704	Guia condensador		2								
	Q012042	Tornillo exagonal M-6x15		4								
	Z310341	Arandela rectangular		4								
	Q262040	Arandela muelle A-6		4								
	Q162040	Tuerca exagonal M-6		4								
10	Z275075	Deslizamiento guias		2								
	Q232040	Arandela plana A-6		4								
	Q222012	Tuerca autoblocante M-6		4								
11	Z271203	Muelle torsion izquierdo		1								Quando la entrada es por la derecha
12	Z276711	Pulsador lavado-condensador		1								Soldado a pulsador lavado
13	Z271211	'U" Soporte pulsadores		1								
	Q232040	Arandela plana A-6		2								
	Q262030	Arandela muelle A-5		2								
	Q212031	Tuerca sombrerete M-5		2								
14	Z271204	Muelle torsion derecho		1								Quando la entrada es por la izquierda
15	Z271201	Soporte pulsador		1								
	Q232040	Arandela plana A-6		2								
	Q262030	Arandela muelle A-5		2								
	Q222017	Tuerca sombrerete M-5		2								

MOD.		LAVAVAJILLAS ARRASTRE COMPACTO		ZONA	TUNEL CONDENSADOR DE VAHOS							PLANO	C-1044
ITEM	CODIGO	DENOMINACION	TEXTO	TUNEL CONDENSADOR									NOTAS
16	Q262040	Arandela muelle A-6		4									
17	Q162040	Tuerca exagonal M-6		4									
18	Z276354	Amarre pata		2									
19	Q012031	Tornillo exagonal M-5x10		4									
20	Q262030	Arandela muelle A-5		4									
21	Z276395	Pata tunel secado y condensador		2									
22	Z276398	Bandeja tunel secado y condensad.		1									
23	Q221342	Remache exagonal M-5		2									
24	Q232040	Arandela plana A-6		2									
25	Q012031	Tornillo exagonal M-5x10		2									
26	Q012031	Tornillo exagonal M-5x10		4									
27	Q262030	Arandela muelle A-5		4									
28	Q221342	Remache exagonal M-5		4									
29	X260150	Pata regulable		2									
	Q232030	Arandela plana A-5		8									
	Q262030	Arandela muelle A-5		8									
	Q162030	Tuerca exagonal M-5		8									
30	Z276410	Cortina interior completa		1									
31	Z275056	Uña arrastre izquierda		4									
32	Q152046	Tornillo exagonal con cuello M-6x15		8									
33	Q232050	Arandela plana A-8		16									
34	Z275057	Uña arrastre derecha		4									
35	Z276311	Soporte uñas		1									
	Q012042	Tornillo exagonal M-6x15		2									Amarre soportes de uñas entre si
	Q232050	Arandela plana A-8		4									Amarre soportes de uñas entre si
	Q262040	Arandela muelle A-6		2									Amarre soportes de uñas entre si
	Q222012	Tuerca autoblocante M-6		2									Amarre soportes de uñas entre si
36	Q262040	Arandela muelle A-6		8									
37	Q222012	Tuerca autoblocante M-6		8									

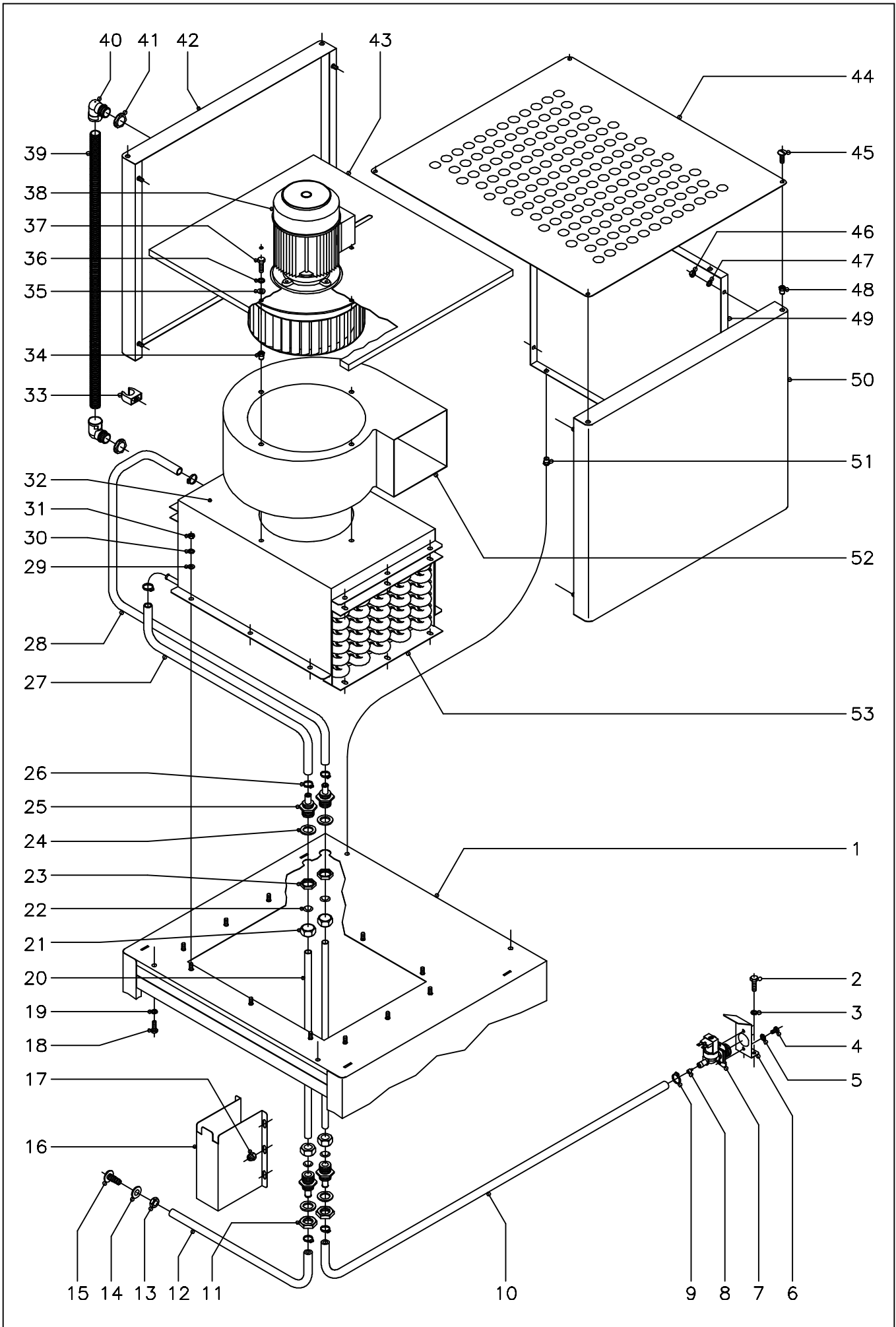

N plano C-1045	Firma <i>[Signature]</i>	Fecha 5-2001	Aparato LAVAVAJILLAS ARRASTRE COMPACTO CONDENSADOR DE VAHOS	Lamina 11	Fagor Industrial S.Coop. FAGOR Onate
-------------------	-----------------------------	-----------------	---	--------------	--

MOD.		LAVAVAJILLAS ARRASTRE COMPACTO		ZONA	CONDENSADOR DE VAHOS							PLANO	C-1045
ITEM	CODIGO	DENOMINACION	TEXTO	CONDENSADOR DE VAHOS								NOTAS	
1	Z276701	Tunel condensador vahos		1									
2	Q012042	Tornillo exagonal M-6x15		2									
3	Q262040	Arandela muelle A-6		2									
4	Q032021	Tornillo alomado M-4x10		2									
5	Q242020	Arandela abanico A-4		2									
6	Z201101	Escuadra amarre electrovalvula		1									
7	Z701135	Electrovalvula simple		1									
8	P443042	Regulador caudal 3 l./min.		1									
9	Q881302	Abrazadera 12 - 20		3									
10	3676900	Tubo de goma Ø 17xØ 10x3000		1								Toma de agua	
11	Q223023	Tuerca exagonal 5/8"		2									
12	3676900	Tubo de goma Ø 17xØ 10x3000		1								Empalme a manguera desagüe	
13	Q223013	Tuerca exagonal M-12		1								Empalme a manguera desagüe	
14	Z600908	Arandela plana Ø26xØ12,5x2		1								Empalme a manguera desagüe	
15	Z600907	Toma de presion		1								Empalme a manguera desagüe	
16	Z276772	Cubierta		1									
17	Q212031	Tuerca sombrerete M-5		6									
18	Q012042	Tornillo exagonal M-6x15		4									
19	Q262040	Arandela muelle A-6		4									
20	Z276761	Tubo empalme		2									
21	Q223108	Tuerca M-24x2,5		4									
22	Q307063	Junta torica Ø19,35xØ12,29xØ3,53		4									
23	Q223031	Tuerca exagonal M-24x2,5		2									
24	Q307032	Arandela junta Ø 32xØ 21x3		4									
25	Z271901	Pasamuros		4									
26	Q881302	Abrazadera 12 - 20		4									
27	3676900	Tubo salida serpen.Ø17xØ10x300		1									
28	3676900	Tubo entrad.serpen.Ø17xØ10x560		1									
29	Q232040	Arandela plana A-6		12									

MOD.		LAVAVAJILLAS ARRASTRE COMPACTO		ZONA	CONDENSADOR DE VAHOS							PLANO	C-1045
ITEM	CODIGO	DENOMINACION	TEXTO	CONDENSADOR DE VAHOS									NOTAS
30	Q262040	Arandela muelle A-6		12									
31	Q162040	Tuerca exagonal M-6		12									
32	Z106764	Cubierta bateria serpentin		1									
33	Z316354	Abrazadera de presion		2									
34	Q221343	Remache exagonal M-6		8									
35	Q232040	Arandela plana A-6		8									
36	Q262040	Arandela muelle A-6		8									
37	Q012042	Tornillo exagonal M-6x15		8									
38	Z316412	Ventilador centrifugo		1									
39	3712300	Tubo plastico Ø 29xØ 23x950		1									
40	Z703006	Racord 90º		2									
41	R023025	Contratuerca		2									
42	Z276752	Posterior cubierta		1									
43	Z276379	Barrera vahos		1									
44	Z276754	Superior de cubierta		1									
45	Q152017	Tornillo amarre M-6x13		4									
46	Q162040	Tuerca exagonal M-6		8									
47	Q262040	Arandela muelle A-6		8									
48	Q221343	Remache exagonal M-6		4									
49	Z276751	Lateral de cubierta		2									
50	Z276342	Anterior de cubierta		1									
51	Q221343	Remache exagonal M-6		4									
52	Z106721	Cubierta ventola		1									
53	Z276762	Bateria -serpentin completo		1									
s/n	Z276781	Instalacion electrica condensador		1									
s/n	Z276392	Instalacion electrica auxiliar conden.		1									
s/n	Z316702	Cableado condensador		1									
s/n	Z316382	Cableado auxiliar condensador		1									

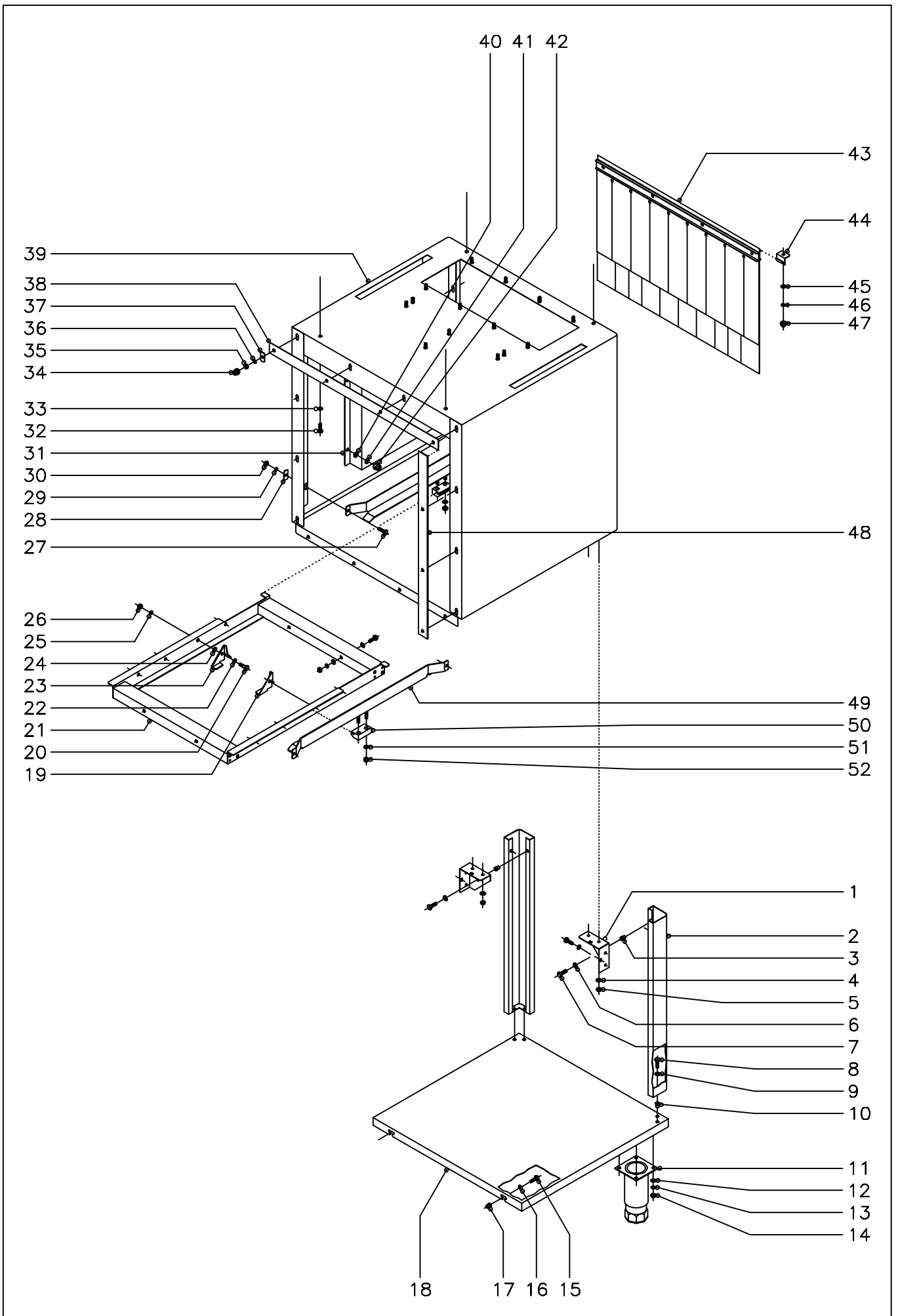

N plano C-1046	Firma 	Fecha 5-2001	Aparato LAVAVAJILLAS ARRASTRE COMPACTO TUNEL DE SECADO (600)	Lamina 12	Fagor Industrial S.Coop. FAGOR Onate
-------------------	-----------	-----------------	--	--------------	--

MOD.		LAVAVAJILLAS ARRASTRE COMPACTO		ZONA	TUNEL DE SECADO (600)						PLANO	C-1046	
ITEM	CODIGO	DENOMINACION	TEXTO	TUNEL DE SECADO 600								NOTAS	
1	Z276354	Amarre pata		2									
2	Z276395	Pata tunel secado y condensador		2									
3	Q221342	Remache exagonal M-5		4									
4	Q262040	Arandela muelle A-6		4									
5	Q162040	Tuerca exagonal M-6		4									
6	Q242030	Arandela abanico A-5		4									
7	Q012031	Tornillo exagonal M-5x10		4									
8	Q012031	Tornillo exagonal M-5x10		4									
9	Q242030	Arandela abanico A-5		4									
10	Q221342	Remache exagonal M-5		4									
11	X260150	Pata regulable		2									
12	Q232030	Arandela plana A-5		8									
13	Q262030	Arandela muelle A-5		8									
14	Q162030	Tuerca exagonal M-5		8									
15	Q012031	Tornillo exagonal M-5x10		2									
16	Q232040	Arandela plana A-6		2									
17	Q221342	Remache exagonal M-5		2									
18	Z276398	Bandeja tunel secado y condensad.		1									
19	Z275056	Uña arrastre izquierda		4									
20	Q152046	Tornillo exag. con cuello M-6x15		8									
21	Z276311	Soporte uñas		1									
	Q012042	Tornillo exagonal M-6x15		2								Amarre soportes de uñas entre si	
	Q232050	Arandela plana A-8		4								Amarre soportes de uñas entre si	
	Q262040	Arandela muelle A-6		2								Amarre soportes de uñas entre si	
	Q222012	Tuerca autoblocante M-6		2								Amarre soportes de uñas entre si	
22	Q232050	Arandela plana A-8		8									
23	Z275057	Uña arrastre derecha		4									
24	Q232050	Arandela plana A-8		8									
25	Q262040	Arandela muelle A-6		8									

MOD.		LAVAVAJILLAS ARRASTRE COMPACTO		ZONA	TUNEL DE SECADO (600)							PLANO	C-1046
ITEM	CODIGO	DENOMINACION	TEXTO	TUNEL DE SECADO 600									NOTAS
26	Q222012	Tuerca autoblocante M-6		8									
27	Q012042	Tornillo exagonal M-6x15		4									
28	Z310341	Arandela rectangular		4									
29	Q262040	Arandela muelle A-6		4									
30	Q162040	Tuerca exagonal M-6		4									
31	Z276321	Ventana aspiracion		2									
32	Q012042	Tornillo exagonal M-6x15		4									
33	Q262040	Arandela muelle A-6		4									
34	Q212040	Tuerca sombrerete M-6		14									
35	Q162040	Tuerca exagonal M-6		14									
36	Q262040	Arandela muelle A-6		14									
37	Z310341	Arandela rectangular		14									
38	Z276204	Junta superior e inferior		2									
39	Z276301	Tunel de secado		1									
40	Q232040	Arandela plana A-6		12									
41	Q262040	Arandela muelle A-6		12									
42	Q212040	Tuerca sombrerete M-6		12									
43	Z276410	Cortina interior completa		1									
44	Z270326	Sujecion cortina		2									
45	Q232040	Arandela plana A-6		2									
46	Q262030	Arandela muelle A-5		2									
47	Q212031	Tuerca sombrerete M-5		2									
48	Z276205	Junta lateral		2									
49	Z276304	Guia secado		2									
50	Z275075	Deslizamiento guias		2									
51	Q232040	Arandela plana A-6		4									
52	Q222012	Tuerca autoblocante M-6		4									

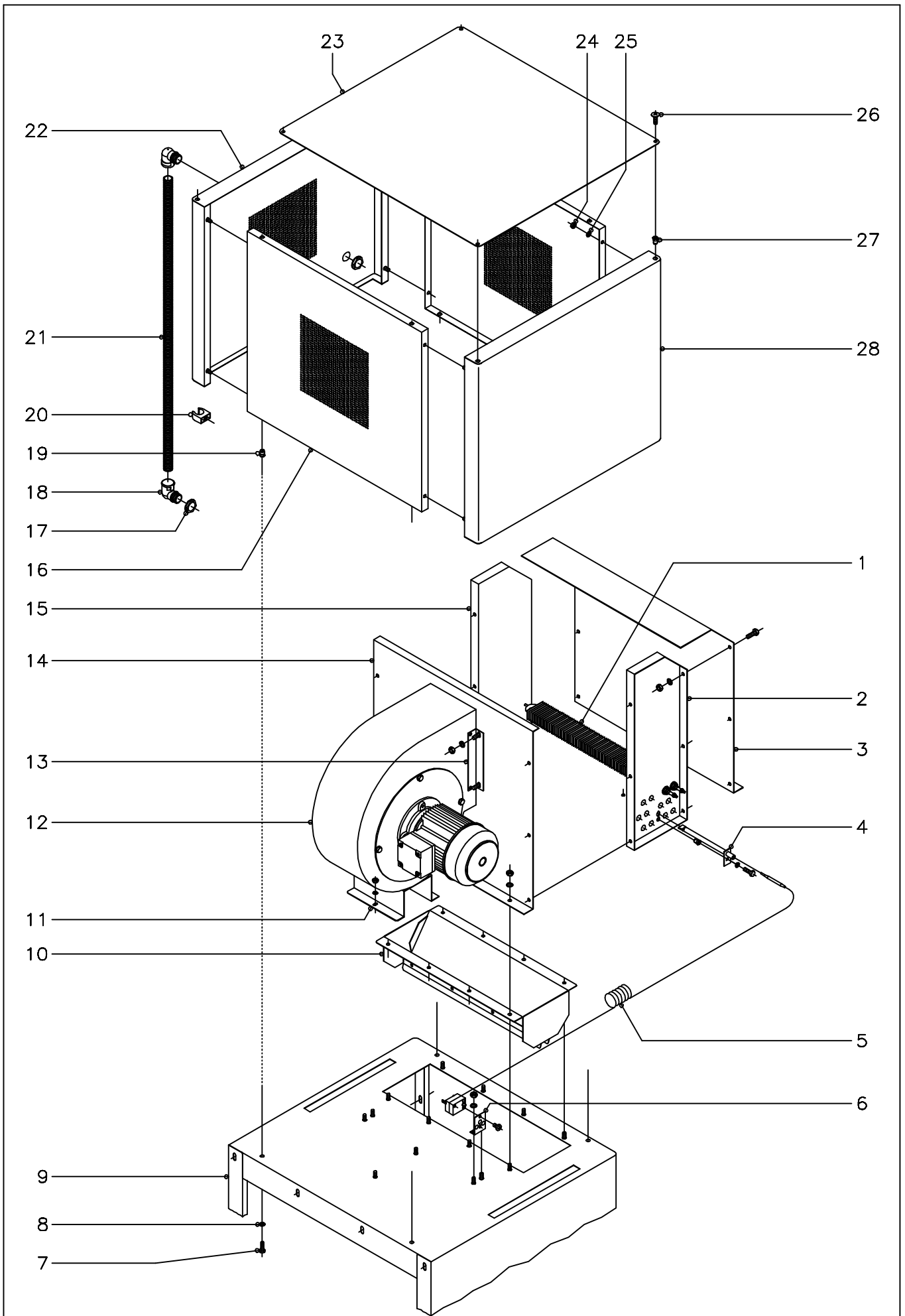

N plano C-1047	Firma 	Fecha 5-2001	Aparato LAVAVAJILLAS ARRASTRE COMPACTO SECADO (600)	Lámina 13	Fagor Industrial S.Coop. FAGOR  Oñate
-------------------	--	-----------------	---	--------------	--

MOD.		LAVAVAJILLAS ARRASTRE COMPACTO		ZONA	SECADO (600)							PLANO	C-1047
ITEM	CODIGO	DENOMINACION	TEXTO	SECADO 600									NOTAS
1	Z276391	Resistencia aletas 1500 W. 230 V.		6									
2	Z276329	Frontal caja resistencias		1									
3	Z276326	Lateral izquierdo caja resistencias		1									
	Q012042	Tornillo exagonal M-6x15		14									
	Q262040	Arandela muelle A-6		14									
	Q162040	Tuerca exagonal M-6		14									
4	Z276331	Vaina para bulbo termostato		1									
	Q012042	Tornillo exagonal M-6x15		1									
	Q262040	Arandela muelle A-6		1									
	Q221343	Remache exagonal M-6		1									
5	Z213014	Termostato limitador		1									
	Q081330	Tornillo alomado BZ-3,5x6,5		2									
6	Z850111	Soporte termostato		1									
	Q232040	Arandela plana A-6		2									
	Q162040	Tuerca exagonal M-6		2									
7	Q012042	Tornillo exagonal M-6x15		4									
8	Q262040	Arandela muelle A-6		4									
9	Z276301	Tunel de secado		1									
10	Z276322	Salida secado completa		1									
11	Z276394	Soporte ventilador		1									
	Q262040	Arandela muelle A-6		2									
	Q162040	Tuerca exagonal M-6		2									
12	Z316412	Ventilador centrifugo		1									
13	Z276375	Amarre ventilador escuadra		2									
	Q262040	Arandela muelle A-6		4									
	Q162040	Tuerca exagonal M-6		4									
14	Z276376	Lateral derecho caja resistencias		1									
	Q262040	Arandela muelle A-6		8									
	Q162040	Tuerca exagonal M-6		8									

MOD.		LAVAVAJILLAS ARRASTRE COMPACTO		ZONA	SECADO (600)							PLANO	C-1047
ITEM	CODIGO	DENOMINACION	TEXTO	SECADO 600									NOTAS
15	Z276330	Posterior caja resistencias		1									
	Q012042	Tornillo exagonal M-6x15		14									
	Q262040	Arandela muelle A-6		14									
	Q162040	Tuerca exagonal M-6		14									
16	Z276345	Lateral cubierta		2									
17	R023025	Contratuerca		2									
18	Z703006	Racord 90°		2									
19	Q221343	Remache exagonal M-6		4									
20	Z316354	Abrazadera de presion		2									
21	3712300	Tubo plastico Ø 29xØ 23x950		1									
22	Z276361	Posterior cubierta		1									
23	Z276346	Superior de cubierta		1									
24	Q162040	Tuerca exagonal M-6		8									
25	Q262040	Arandela muelle A-6		8									
26	Q152017	Tornillo amarre M-6x13		4									
27	Q221343	Remache exagonal M-6		4									
28	Z276342	Anterior de cubierta		1									
s/n	Z276341	Instalacion electrica secado		1									
s/n	Z276392	Instalacion electrica auxiliar secado		1									
s/n	Z316381	Cableado secado		1									
s/n	Z316382	Cableado auxiliar secado		1									

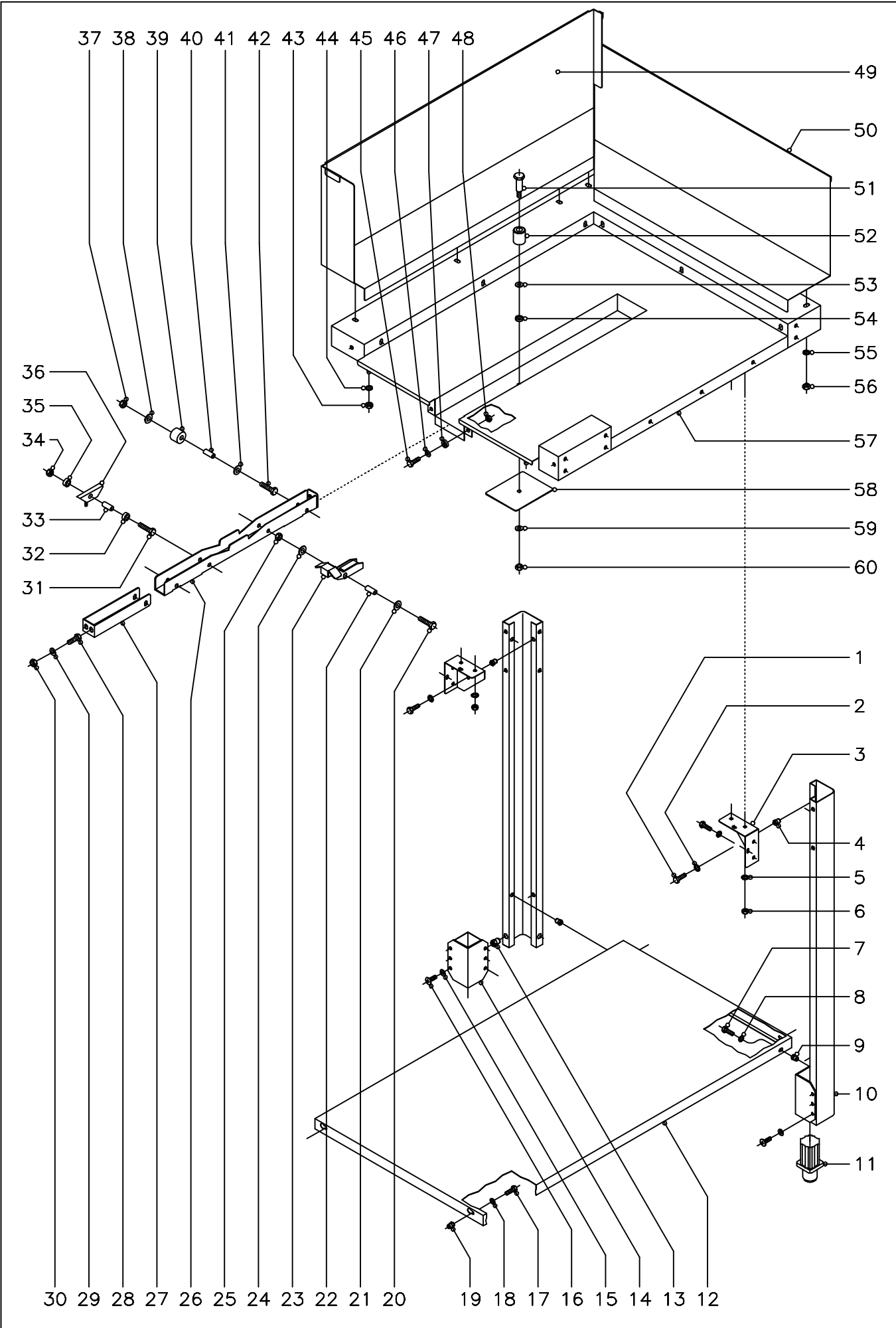

MOD.		LAVAVAJILLAS DE ARRASTRE		ZONA		CARGADOR ENTRADA EN ANGULO 90°					PLANO		C-1048
ITEM	CODIGO	DENOMINACION	TEXTO	CARGADOR ENTRADA 90° DERECHA	CARGADOR ENTRADA 90° IZQUIERDA								NOTAS
1	Q012031	Tornillo exagonal M-5x10		4	4								
2	Q242030	Arandela abanico A-5		4	4								
3	Z276354	Amarre pata		2	2								
4	Q221342	Remache exagonal M-5		4	4								
5	Q242040	Arandela abanico A-6		4	4								
6	Q162040	Tuerca exagonal M-6		4	4								
7	Q012031	Tornillo exagonal M-5x10		4	4								
8	Q242030	Arandela abanico A-5		4	4								
9	Q221342	Remache exagonal M-5		4	4								
10	Z272505	Pata		2	2								
11	R675610	Pata regulable		2	2								
12	Z272506	Bandeja inferior		1	1								Con modulo de entrada
12	Z296301	Bandeja inferior		1	1								Con condensador de vahos
13	Q221343	Remache exagonal M-6		4	4								
14	Z282516	Regulador pata		2	2								
15	Q232040	Arandela plana A-6		4	4								
16	Q152017	Tornillo amarre M-6x13		4	4								
17	Q012031	Tornillo exagonal M-5x10		2	2								
18	Q242030	Arandela abanico A-5		2	2								
19	Q221342	Remache exagonal M-5		2	2								
20	Q012046	Tornillo exagonal M-6x40		1	1								
21	Q232050	Arandela plana A-8		1	1								
22	Z105058	Eje separador		1	1								
23	Z102537	Uña 90°		1	1								
24	Q232050	Arandela plana A-8		1	1								
25	Q221301	Tuerca autoblocante M-6		1	1								
26	Z102536	Carro arrastre		1	1								
27	Z272528	Horquilla		1	1								
28	Q012042	Tornillo exagonal M-6x15		2	2								

MOD.		LAVAVAJILLAS DE ARRASTRE		ZONA		CARGADOR ENTRADA EN ANGULO 90°					PLANO		C-1048
ITEM	CODIGO	DENOMINACION	TEXTO	CARGADOR ENTRADA 90° DERECHA	CARGADOR ENTRADA 90° IZQUIERDA								NOTAS
29	Q232040	Arandela plana A-6		2	2								
30	Q222012	Tuerca autoblocante M-6		2	2								
31	Q012046	Tornillo exagonal M-6x40		1	1								
32	Z105059	Casquillo separador		1	1								
33	Z105058	Eje separador		1	1								
34	Q222012	Tuerca autoblocante M-6		1	1								
35	Z105059	Casquillo separador		1	1								
36	Z105060	Uña arrastre		1	1								
37	Q222012	Tuerca autoblocante M-6		2	2								
38	Q232050	Arandela plana A-8		2	2								
39	Z105057	Rodillo		2	2								
40	Z105058	Eje separador		2	2								
41	Q232050	Arandela plana A-8		2	2								
42	Q012046	Tornillo exagonal M-6x40		2	2								
43	Q162040	Tuerca exagonal M-6		2	2								
44	Q242040	Arandela abanico A-6		2	2								
45	Q012042	Tornillo exagonal M-6x15		4	4								
46	Q232040	Arandela plana A-6		4	4								
47	Q308002	Arandela dubo A-6		4	4								
48	Q222012	Tuerca autoblocante M-6		4	4								
49	Z282542	Peto 90° derecha posterior		1	-								
s/n	Z282532	Peto 90° izquierda posterior		-	1								
50	Z282544	Peto 90° derecha lateral		1	-								
s/n	Z282534	Peto 90° izquierda lateral		-	1								
51	Q102548	Tornillo coginete		1	1								
52	Z102549	Rodillo		1	1								
53	Q232050	Arandela plana A-8		1	1								
54	Q308000	Arandela dubo A-8		1	1								

FI-160 FI-160T FI-200 FI-200H

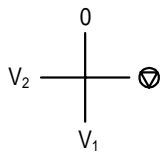
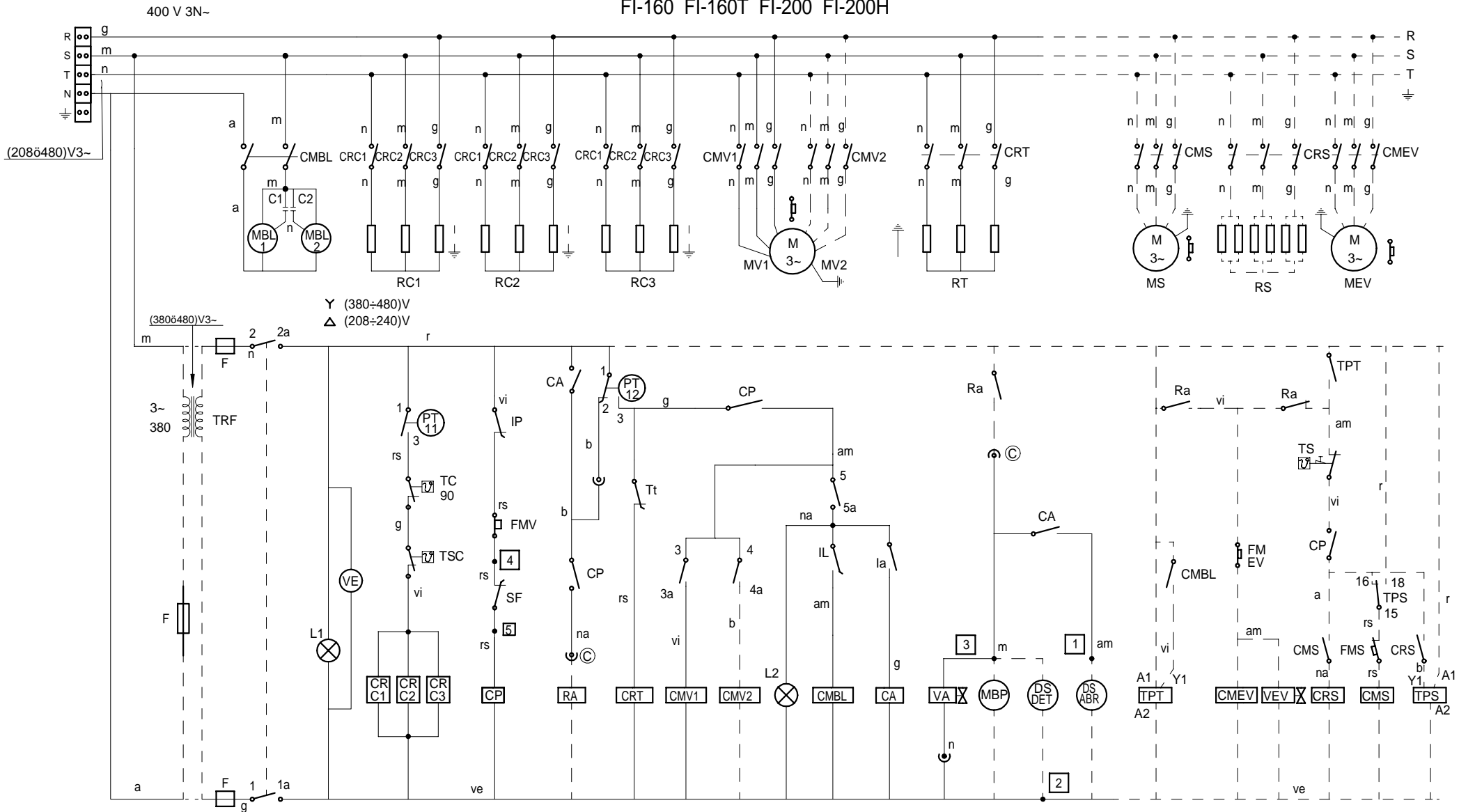

CODIGO COLORES - CODE DES COULEURS - COLOUR CODE - FARBE CODE - CODICE DI COLORE

- n = Negro-Noir-Black-Schwarz-Nero
- a = Azul-Bleu-Blue-Blau-Blu
- r = Rojo-Rouge-Red-Rot-Rosso
- b = Blanco-Blanc-White-Blank-Bianco
- g = Gris-Gris-Grey-Gran-Grigio
- m = Marron-Marron-Brown-Braun-Marrone
- na = Naranja-Orange-Orange-Orange-Arancino
- vi = Violeta-Violette-Violet-Viole-Violetta
- ve = Verde-Vert-Green-Grün-Verde
- rs = Rosa-Rose-Pink-Rose-Roseo
- am = Amarillo-Jaune-Yellow-Gelb-Giallo
- am/ve = Amarillo-Verde/Jaune-Vert/Yellow-Green/Gelb-Grün/Giallo-Verde

IG	1 1a	2 2a	3 3a	4 4a	5 5a	6 6a
0						
⊕	X	X				
V ₁	X	X	X		X	X
V ₂	X	X		X	X	X

Esquema teórico FI-160, FI-160T, FI-200, FI-200H			Z-273018	
Nº	Pieza	Nº Clasificación	Acabado	
Nº	Modificación	Propuesta de	Fecha	
(1)	Introducir ©	Maillo	31-1-02	
Firma		Fecha	Tolerancias generales	
Dibujado		S. N.	2-2-01	
Proyectado		FAGOR		Mecanizado superficial
Comprobado		Fagor Industrial, Koop, Elk, Mugatua		
Escala		LAVAVAJILLAS		Plano numero
				HC-17294 -1
				Sustituye al Nº
				HD-16214
				Sustituido por

Plano hau ez daiteke erabili ez berrizta gure baimeniz gabe

ECO-160 ECO-160T ECO-200 ECO-200H

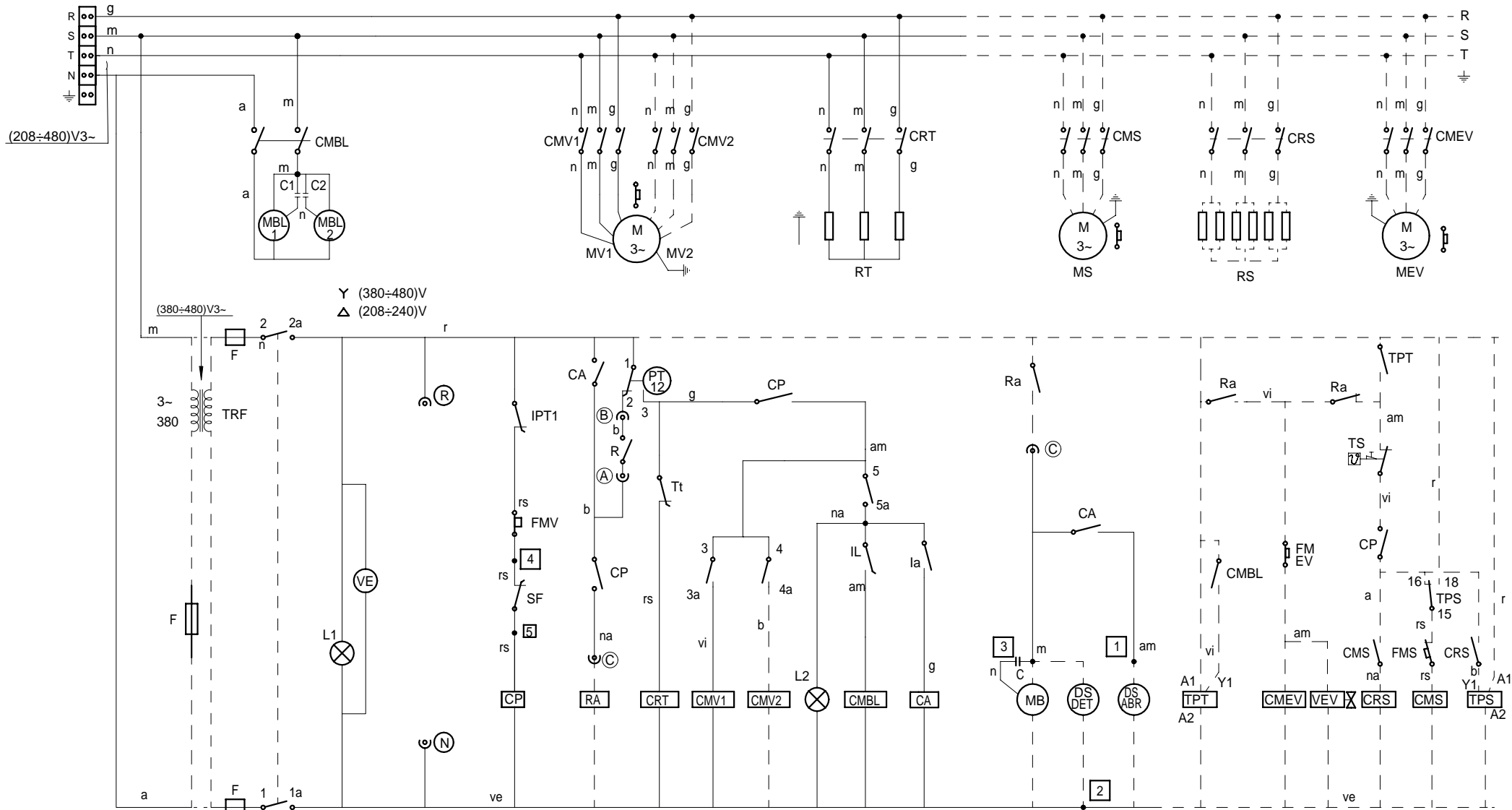

CODIGO COLORES - CODE DES COULEURS - COLOUR CODE - FARBE CODE - CODICE DI COLORE

n = Negro-Noir-Black-Schwarz-Nero
a = Azul-Bleu-Blue-Blau-Blu
r = Rojo-Rouge-Red-Rot-Rosso
b = Blanco-Blanc-White-Blank-Bianco
g = Gris-Gris-Grey-Gran-Grigio
m = Marron-Marron-Brown-Braun-Marrone
na = Naranja-Orange-Orange-Arancio
vi = Violeta-Violette-Violet-Viole-Violetta
ve = Verde-Vert-Green-Grün-Verde
rs = Rosa-Rose-Pink-Rose-Roseo
am = Amarillo-Jaune-Yellow-Gelb-Giallo
am/ve = Amarillo-Verde/Jaune-Vert/Yellow-Green/Gelb-Grün/Giallo-Verde

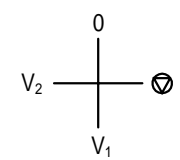

IG	1 1a	2 2a	3 3a	4 4a	5 5a	6 6a
0						
⊗	X	X				
V ₁	X	X	X		X	X
V ₂	X	X		X	X	X

Esquema teórico ECO-160, ECO-160T, ECO-200, ECO-200H		Z-283020	
Nº	Pieza	Nº Clasificación	Acabado
Nº	Modificación	Propuesta de	Fecha
(1)	Introducir (A)(B)(C)	Maillo	1-2-2002
Firma		Fecha	 Fagor Industrial, Koop. Elk, Mugatua
Dibujado		S. N.	
Proyectado		28-2-01	
Comprobado			
Escala		<p style="text-align: center;">LAVAVAJILLAS</p> <p style="font-size: small;">Plano hau ez daitake erabil ez berritza gure baimenitz gabe</p>	
			Mecanizado superficial
			Plano numero
			HC-17304 -1
			Sustituye al Nº HD-16215
			Sustituido por

ESPAÑOL

(A) (B) = Puntos de conexión con R
 (C) = Puntos de conex.160/200 sin secado ni condensador
 C,C1,C2 = Condensador
 CA = Rele auxiliar aclarado
 CMBL 1/2 = Contactor bomba lavado 1/2
 CMBPL = Contactor bomba prelavado
 CMEV = Contactor motor extractor
 CMS = Contactor motor secado
 CMV 1/2 = Contactor avance 1/2
 CMREC = Contactor motor recuperador
 CRC 1/2/3 = Contactor calentamiento calderín
 CRS = Contactor resistencia secado
 CRTA = Contactor calentamiento aclarado
 CRT2 = Contactor calentamiento tanque 2
 CRT11/12 = Contactor calentamiento tanque 1
 CP = Rele puerta
 DS.ABR = Dosificador abrillantador
 DS.DET.= Dosificador detergente
 F = Fusible
 FMEV = Rele termico motor extractor
 FML1/2 = S. Termico bomba lavado 1/2
 FMS = Rele termico motor secado
 FMREC = Rele termico motor recuperador
 FMV = S. Termica motor avance
 Ia = Micro aclarado
 IG = Interruptor general
 IL = Micro lavado
 IPA = Micro puerta aclarado
 IPPL = Micro puerta prelavado
 IPT1/2 = Micro puerta tanque 1/2
 L1 = Piloto de encendido
 L2 = Piloto marcha
 MB = Bomba de llenado y adarado
 MBA = Bomba aclarado
 MBL1/2 = Bomba lavado 1/2
 MBP = Bomba de presión
 MBPL = Bomba prelavado
 MEV = Motor extractor vahos
 MREC = Motor recuperador
 MS = Motor secado
 MV = Motor avance
 Pa = Presostato aclarado
 PPL = Presostato prelavado
 PT2/PT22 = Presostato lavado 2 llenado
 PT11 = Presostato lavado 1 calentamiento
 PT12 = Presostato lavado 1 llenado
 PT21 = Presostato lavado 2 calentamiento
 R = Rele de Generador A.C.
 (R) (N) = Toma de alimentación Generador A.C.
 Ra = Rele auxiliar aclarado y llenado
 RC1/2/3 = Resistencia calderín
 RS = Resistencia secado
 RTA = Resistencia calentamiento aclarado
 RT2 = Resistencia tanque 2
 RT11/12 = Resistencia tanque 1
 SF = Micro fin recorrido
 TA = Termostato aclarado
 TC = Termostato calderín
 TPT = Temporizador inicio
 TPS = Temporizador secado
 TREC = Termostato recuperador
 TRF = Transformador
 TS = Termostato secado
 TSC = Limitador calderín
 Tt1/2 = Termostato tanque 1/2
 VA = Electrovalvula llenado y adarado
 VE = Ventilador cuadro electrico
 VEV = Electrovalvula condensacion vahos
 VL1/2 = Electrovalvula llenado tanque
 VG = Electrovalvula general
 VREC = Electrovalvula salida

FRANÇAIS

Points de conexión R
 Points de conexión 160/200 sans sechege ni condensateur
 Condensateur
 Relais auxiliaire rinçage
 Contacteur pompe lavage 1/2
 Contacteur pompe prelavage
 Contacteur moteur extracteur
 Contacteur moteur sechage
 Contacteur avance 1/2
 Contacteur moteur recuperateur
 Contacteur chauff. surchauffeur
 Contacteur resistances sechage
 Contacteur chauffage rinçage
 Contacteur chauffage cuve 2
 Contacteur chauffage cuve 1
 Relais porte
 Dosseur de tensoactif
 Dosseur de detergent
 Fusible
 Relais thermique moteur extracteur
 S. Thermique pompe lavage 1/2
 Relais thermique moteur sechage
 Relais thermique moteur recuperateur
 S. Thermica moteur avance
 Micro rinçage
 Interrupteur general
 Micro lavage
 Micro porte rinçage
 Micro porte prelavage
 Micro porte cuve 1/2
 Voyant fonctionnement
 Voyant demarrage
 Pompe remplissage rinçage
 Pompe rinçage
 Pompe lavage 1/2
 Pompe de pression
 Pompe prelavage
 Moteur extracteur vapeur
 Moteur recuperateur
 Moteur sechage
 Moteur avance
 Pressostat rinçage
 Pressostat prelavage
 Pressostat lavage 2 remplissage
 Pressostat lavage 1 chauffage
 Pressostat lavage 1 remplissage
 Pressostat lavage 2 chauffage
 Relais du Generateur
 Alimentation generateur
 Relais auxiliaire rinçage remplissage
 Resistance surchauffeur
 Resistance sechage
 Resistance chauffage rinçage
 Resistance cuve 2
 Resistance cuve 1
 Micro fin de course
 Thermostat de rinçage
 Thermostat surchauffeur
 Temporisateur demarrage
 Temporisateur sechage
 Thermostate recuperateur
 Transformateur
 Thermostat sechage
 Thermostat limiteur surchauffeur
 Thermostat cuve 1/2
 Electrovanne remplissage rinçage
 Ventilateur tableau electrique
 Electrovanne condenseur vapeur
 Electrovanne remplissage cuve
 Electrovanne general
 Electrovanne demarrage

LEYENDA COMPACTO Y MODULAR

ENGLISH

Conecction point with R
 Connection points 160/200 without drying nor condenser
 Condenser
 Rinse auxiliary relay
 Wash pump contactor 1/2
 Pre-Wash pump contactor
 Exhaust motor contactor
 Drying motor contactor
 Advance contactor 1/2
 Motor recover contactor
 Boiler heating contactor
 Drying heating element contactor
 Rinse heating contactor
 Tank heating contactor 2
 Tank heating contactor 1
 Door relay
 Rinse doser
 Detergent doser
 Fuse
 Thermic switch exhaust motor relay
 Thermic switch washp 1/2
 Drying motor thermic relay
 Thermic switch recover motor
 Thermic switch rack pulling motor
 Rinse microswitch
 Main switch
 Wash microswitch
 Rinse door microswitch
 Pre-wash door microswitch
 Micro porte cuve 1/2
 Operation light
 Start light
 Fill and rinse pump
 Rinse pump
 Wash pump 1/2
 Pressure pump
 Pre-wash pump
 Exhaust steam motor
 Recover motor
 Drying motor
 Motor advance
 Rinse level switch
 Pre-wash level switch
 Wash level 2 and fill switch
 Wash level 1 and heating switch
 Wash level 1 and fill switch
 Wash level 2 and heating switch
 Generator rele
 Water heater feeding
 Rinse and fill auxiliary relay
 Boiler heating element
 Drying heating element
 Rinse heating heater
 Tank heater 2
 Tank heater 1
 Safety end switch
 Rinse thermostat
 Boiler thermostat
 Start timer
 Drying timer
 Recover thermostat
 Transformer
 Drying thermostat
 Boiler Hi-limit thermostat
 Tank thermostat 1/2
 Fill and rinse valve
 Switchboard fan
 Exhaust condenser solenoid valve
 Tank fill valve
 Main valve
 Outlet solenoid valve

DEUTSCH

Anschlusspunkte mit R
 Anschlusspunkte 160/200 weder ohne Trocknung noch Kondensator
 Kondensator
 Hilfsrelais Spülen
 Kontaktschütz Waschpumpe 1/2
 Kontaktschütz Vorwaschpumpe
 Kontaktschütz Abzugsmotor
 Kontaktschütz Trocknungsmotor
 Kontaktschütz Vorlauf 1/2
 Kontaktschütz Rekuperatormotor
 Kontaktschütz Boilerheizung
 Kontaktschütz Trocknungselektrowiderstand
 Kontaktschütz Spülheizung
 Kontaktschütz Heizung Tank 2
 Kontaktschütz Heizung Tank 1
 Türrelais
 Dosierer Glanzmittel
 Dosierer Spülmittel
 Sicherung
 Thermorelais Abzugsmotor
 Thermoschalter Waschpumpe 1/2
 Thermorelais Trocknungsmotor
 Thermorelais Rekuperatormotor
 Thermoschalter Vorlaufmotor
 Mikroschalter Spülen
 Hauptschalter
 Mikroschalter Waschen
 Mikroschalter Tür Spülen
 Mikroschalter Tür Vorwaschen
 Mikroschalter Tür Tank 1/2
 Betriebsanzeigelampe
 Startanzeigelampe
 Füll- und Spülpumpe
 Spülpumpe
 Waschpumpe 1/2
 Druckpumpe
 Vorwaschpumpe
 Motor Dampfabzug
 Rekuperatormotor
 Trocknungsmotor
 Vorlaufmotor
 Druckregler Spülen
 Druckregler Vorwaschen
 Druckregler Waschstufe 2 Füllen
 Druckregler Waschstufe 1 Heizen
 Druckregler Waschstufe 1 Füllen
 Druckregler Waschstufe 2 Heizen
 Relais Generator
 Stromversorgungsanschluss Generator
 Hilfsrelais Spülen und Füllen
 Boilerheizwiderstand
 Heizwiderstand Trocknen
 Heizwiderstand Spülen
 Heizwiderstand Tank 2
 Heizwiderstand Tank 1
 Mikroschalter Zyklusende
 Thermostat zum Spülen
 Thermostat kessel
 Start-Timer
 Trocknungs-Timer
 Rekuperator-Timer
 Transformator
 Trocknungsthermostat
 Grenztthermostat Boiler
 Thermostat Tank 1/2
 Elektroventil Füllen und Spülen
 Schalttafelventilator
 Elektroventil Dampfkondensation
 Elektroventil Tankfüllung
 Hauptelektroventil
 Ausgangselektroventil

ITALIANO

Punti di collegamento con R
 Punti di collegamento 160/200 senza asciugatura né condensatore
 Condensatore
 Rele ausiliario risciacquo
 Contattore pompa lavaggio 1/2
 Contattore pompa prelavaggio
 Contattore motore estrattore
 Contattore motore asciugatura
 Contattore avanzamento 1/2
 Contattore motore recuperatore
 Contattore riscaldamento boiler
 Contattore resistenza asciugatura
 Contattore riscaldamento risciacquo
 Contattore riscaldamento serbatoio 2
 Contattore riscaldamento serbatoio 1
 Rele porta
 Dosatore brillantante
 Dosatore detersivo
 Fusibile
 Rele termico motore estrattore
 Rele termico pompa lavaggio 1/2
 Rele termico motore asciugatura
 Contattore motore recuperatore
 Rele termico motore avanzamento
 Microinterruttore risciacquo
 Interruttore generale
 Microinterruttore lavaggio
 Microinterruttore porta risciacquo
 Microinterruttore porta prelavaggio
 Microinterruttore porta serbatoio 1/2
 Spia accensione
 Spia avvio
 Pompa di riempimento e risciacquo
 Pompa risciacquo
 Pompa lavaggio 1/2
 Pompa a pressione
 Pompa prelavaggio
 Motore estrazione vapore
 Motore recuperatore
 Motore asciugatura
 Motore avanzamento
 Pressostato risciacquo
 Pressostato prelavaggio
 Pressostato lavaggio 2 riempimento
 Pressostato lavaggio 1 riscaldamento
 Pressostato lavaggio 1 riempimento
 Pressostato lavaggio 2 riscaldamento
 Rele Generator
 Alimentazione generatore
 Rele ausiliario risciacquo e riempimento
 Resistenza boiler
 Resistenza asciugatura
 Resistenza riscaldamento risciacquo
 Resistenza serbatoio 2
 Resistenza serbatoio 1
 Microinterruttore finecorsa
 Termostato risciacquo
 Termostato boiler
 Timer avvio
 Timer asciugatura
 Termostato recuperatore
 Trasformatore
 Termostato asciugatura
 Termostato limitatore boiler
 Termostato serbatoio 1/2
 Elettrovalvola riempimento e risciacquo
 Ventilatore quadro elettrico
 Elettrovalvola condensazione vapore
 Elettrovalvola riempimento serbatoio
 Elettrovalvola generale
 Elettrovalvola uscita