TECHNIC SPARE PARTS DRAWINGS

WASHER EXTRACTORS

SERIES "EVOLUTION TECHNOLOGY"

Model:

LA-13 M

March 2009



Fagor Industrial



Fagor Industrial

WASHER EXTRACTOR MODEL LA-13 M

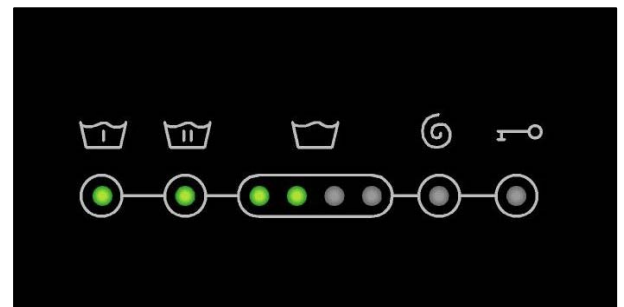
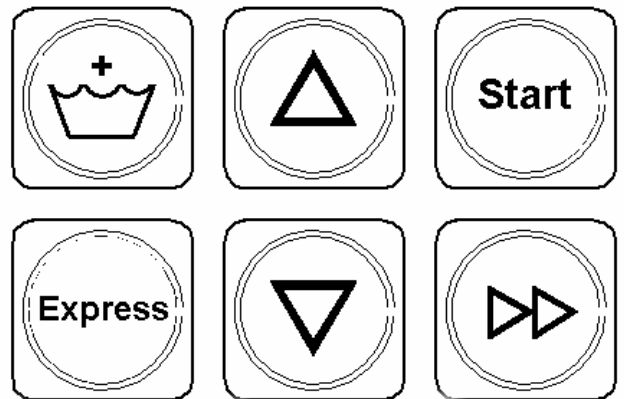

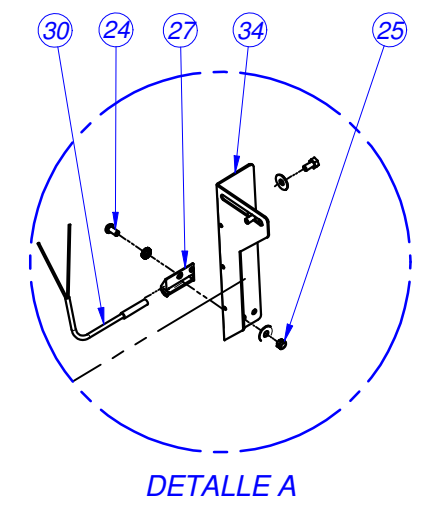
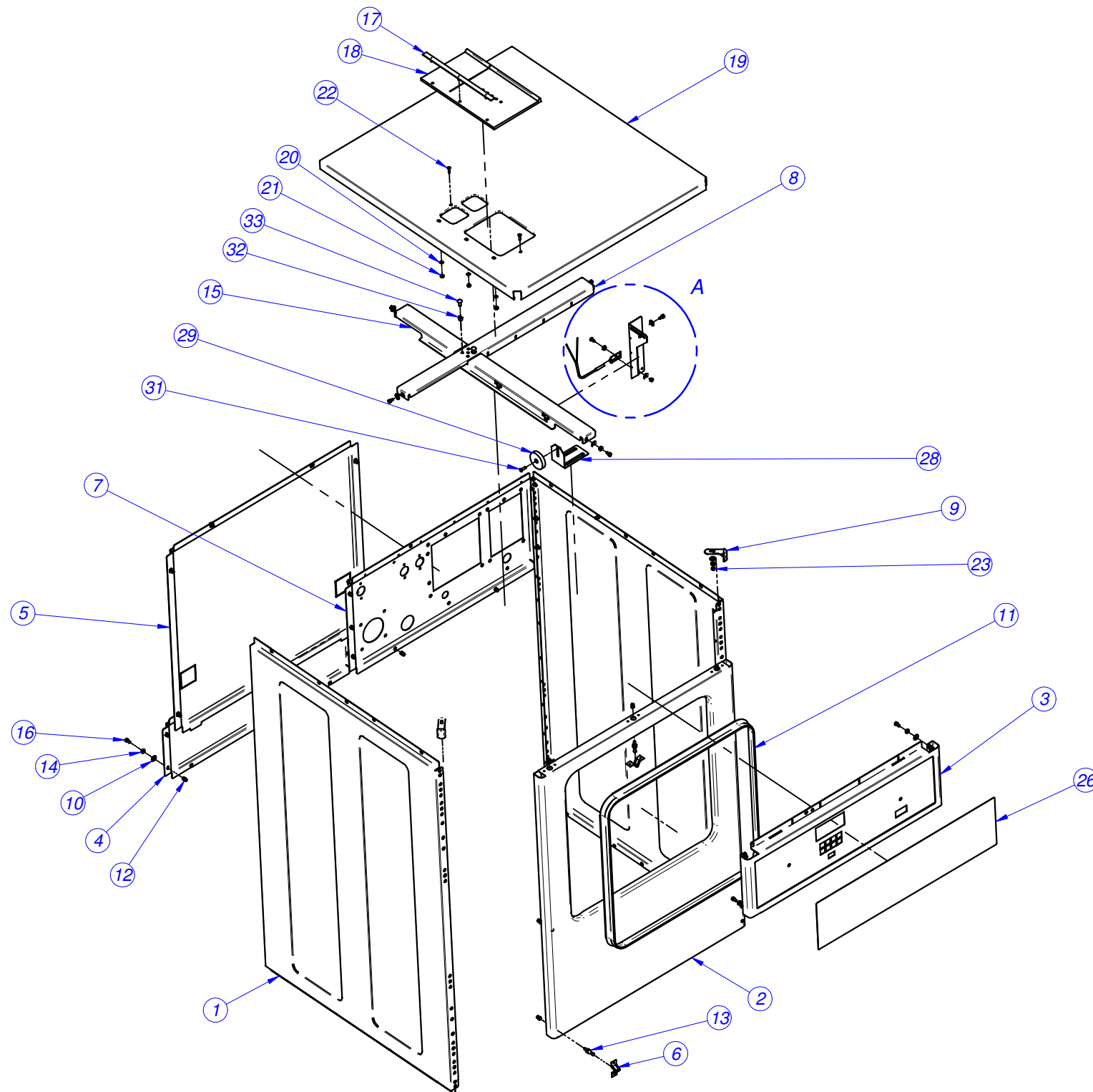

MOD.	WASHER EXTRACTOR 13		ZONA	FITTING	
Nº	CODIGO	DENOMINACION	Cant.		
1	P620360000	SIDE PANEL 13 V2	2		
2	P620301000	FRONT PANEL 13	1		
3	P620367000	CONTROL HOLDER 13 M COMP.	1		
4	P620306000	REAR PANEL DRAIN PIPE 13	1		
5	P620334000	REAR PANEL 13 V2	1		
6	X010503000	SPRING LOCK FREI.700	7		
7	P620331000	INLETS REAR PANEL 13 V2	1		
8	P620354000	PARALLEL CROSSBAR 13 V2	1		
9	P620316000	TOP CORNER PROTECTOR	2		
10	Q302022000	WASHER 16X6X1.2 A.304	31		
11	P620324000	CURTAIN LF-13/18	1		
12	Q221342000	HEXAGONAL RIVET M5	32		
13	X012612000	LOCK SPIKE	7		
14	Q242030000	WASHER A5 A.304	26		
15	P620353000	LONGITUDINAL CROSSBAR 13 V3	1		
16	Q012031000	HEX BOLT M5X10 A.304	28		
17	P440705000	TUB TRAY SUPPORT, COMPLETE	1		
18	P440704000	TRAY LID 1002436	1		
19	P620345000	LF-13 COMP. WORKTOP	1		
20	Q232030000	WASHER A5	3		
21	Q162030000	HEX NUT M5	3		
22	Q042022000	COUNTERSUNK SCREW M4X15	2		
23	Q221308000	HEX.SCREW.AUT.M5 H.ZINC	2		
24	Q032031000	SCREW M5X10	1		
25	Q222030000	SELF-LOCK.NUT.M5	1		
26	P610347000	FAGOR M BUTTON LABEL	1		
27	Z203010000	MAGNETIC SWITCH FASTENER	1		
28	P627063000	MAGNET SUPPORT V2	1		
29	P620337000	IMBALANCE MAGNET DIAM. 50	1		
30	Z203009000	MAGNETIC SWITCH	1		
31	Q042032000	COUNTERSUNK SCREW M5X15 A304	1		
32	Q411310000	MAXLOK COLLAR 6.4	2		
33	Q411309000	MAXLOK RIVET 6.4	2		
34	P630315000	SAFETY MICRO BRACKET 18	1		

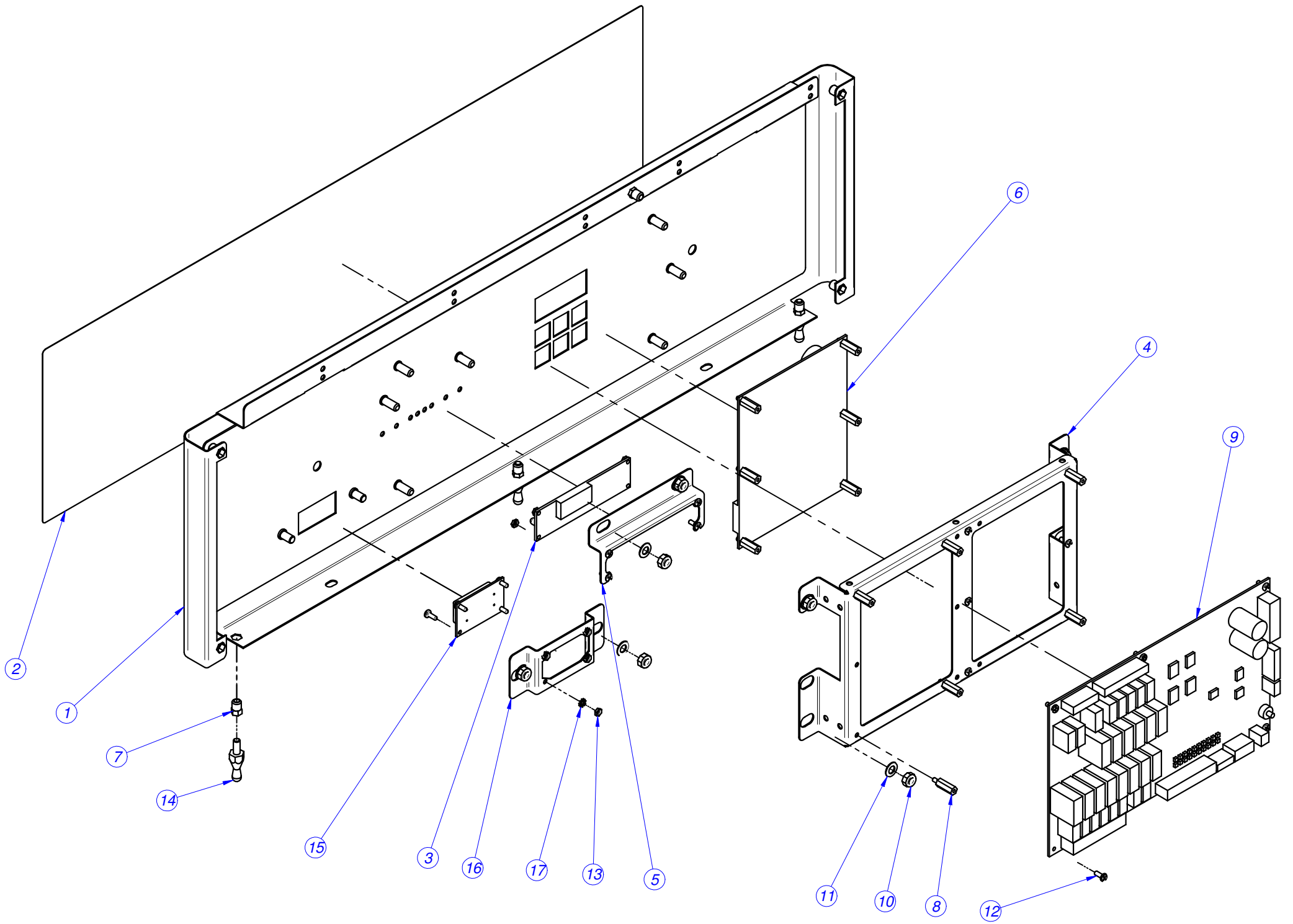

MOD.	WASHING MACHINE LA-13M		ZONE	CONTROL HOLDER	
No	CODE	DENOMINATION	Quant.		
1	P620367000	CONTROL HOLDER COMP.M 13	1		
2	P610347000	ADHESIVE CONTROL HOLDER M	1		
3	P623023000	LED PLATE	1		
4	P620355000	PROGRAMMER SUPPORT M	1		
5	P620356000	LED PLATE SUPPORT	1		
6	P613018000	DISPLAY CIRCUIT M	1		
7	Q221342000	HEXAGONAL RIVET M5	8		
8	T133007000	SPACER M3	12		
9	P613019000	INLET-OUTLET PLATE M	1		
10	Q222012000	SELF-LOCK.NUT.M6	8		
11	Q232040000	WASHER A6	8		
12	T133008000	ANCHORING SCREW M3	17		
13	Q162010000	HEX.SCREW.M3	18		
14	X012612000	LOCK SPIKE	3		
15	P623017000	C.I. POWER SWITCH	1		
16	P620338000	C.I. SWITCH HOLDER	1		
17	Q242010000	WASHER A.3 A304	27		

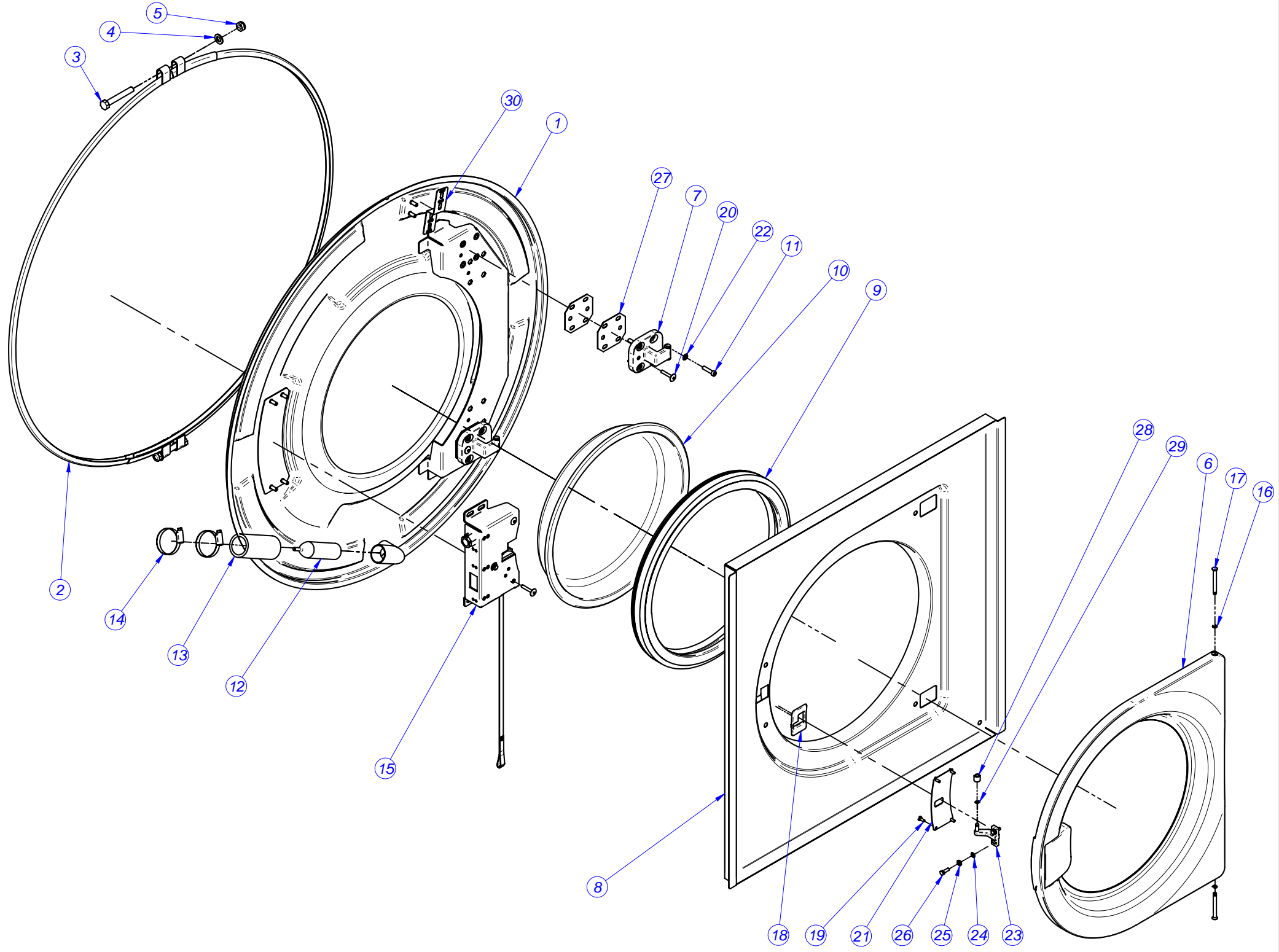

MOD.	WASHER EXTRACTOR 13		ZONA	TUB FRONT	
Nº	CODIGO	DENOMINACION	Cant.		
1	P626112000	COMPLETE TUB FRONT 13	1		
2	P626118000	COMPL. TUB LOCK 13	1		
3	Q011369000	HEX.SCREW.M10X70 H.ZINC	2		
4	Q232060000	WASHER A10	2		
5	Q221306000	HEX.SCREW.AUT.M10 8.8 ZINC	2		
6	P620527000	DOOR FRAME 13,18,25	1		
7	P620502000	DOOR HINGE	2		
8	P620501000	DOOR FRONT PANEL 13.18	1		
9	P620528000	DOOR GASKET 13,18,25	1		
10	P530503000	DOOR GLASS	1		
11	Q122044000	BOLT, ALLEN M6x25	8		
12	P445002000	PRESSURE SWITCH	1		
13	P502106000	OVERFLOW PIPE	1		
14	Q881306000	CLAMP 32-50L	2		
15	P620531000	COMPLETE LOCK 13,18,25	1		
16	Q272020000	SAFETY WASHER 4	2		
17	P620514000	DOOR PIN	2		
18	P620515000	LOCK TRIM	1		
19	Q032021000	CURVED SCREW M4X10	4		
20	Q152038000	BOLT M5X30	4		
21	P620512000	LOCK COVER 13.18	1		
22	Q232040000	WASHER A6	8		
23	P620505000	LOCK ADJUSTABLE HOOK	1		
24	Q232030000	WASHER A5	2		
25	Q242030000	WASHER A5 A.304	2		
26	Q012032000	HEX BOLT M5X15 A.304	2		
27	P620521000	HINGE WEDGE	4		
28	P610506000	DOOR BUSHING	1		
29	Q302061000	SAF. RING A6 DIN471	1		
30	P626128000	PRESSOSTAT PIPE SUPPORT	1		

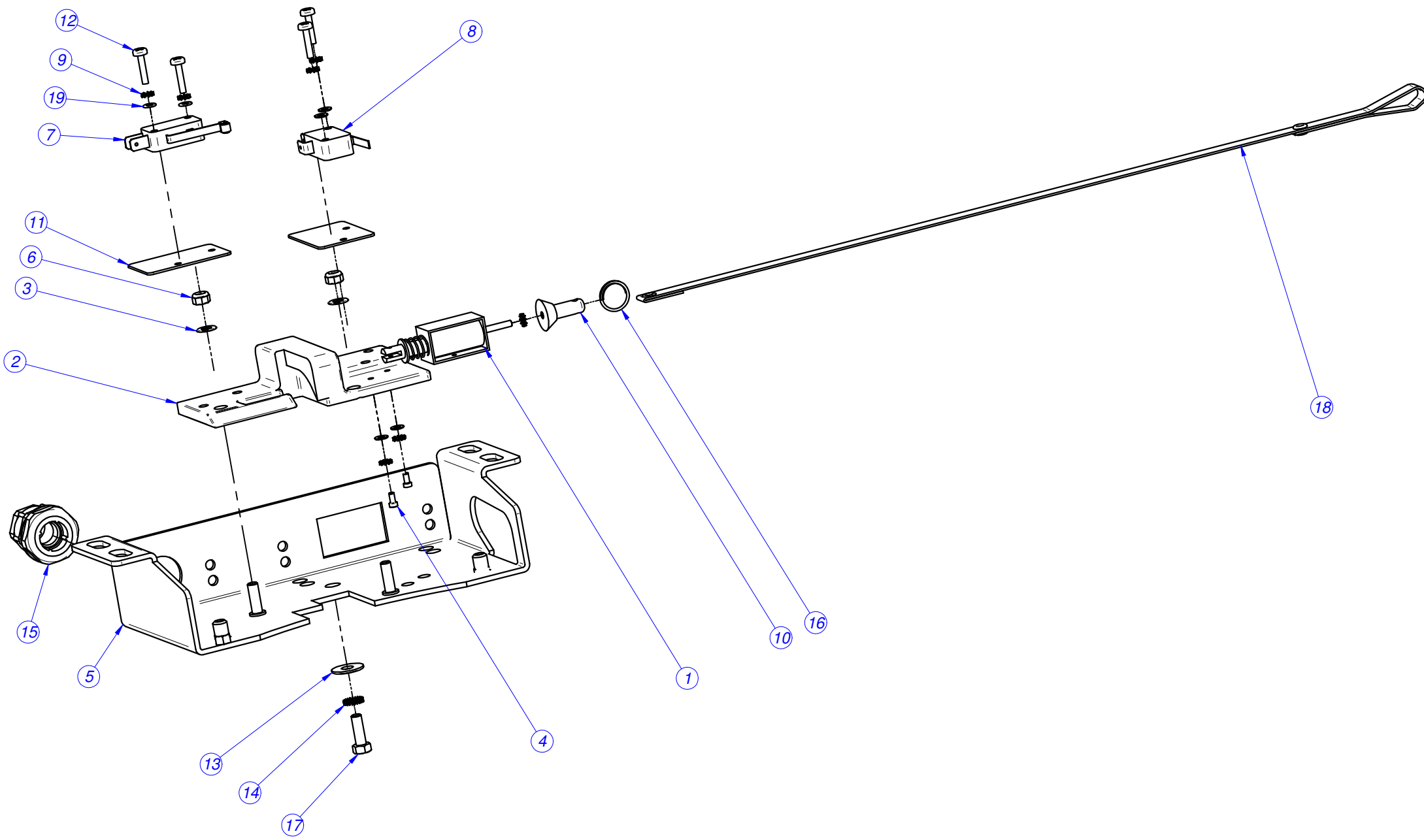

MOD.	WASHER EXTRACTOR 13		ZONA	LOCK	
Nº	CODIGO	DENOMINACION	Cant.		
	P620531000	COMPLETE LOCK	1		
1	P613002000	DOOR ELECTROMAGNET	1		
2	P620522000	LOCK BASE V2	1		
3	Q232030000	WASHER A5	2		
4	Q151396000	BOLT, ALLEN M2.5x5	2		
5	P620530000	COMPLETE LOCK WEDGE	1		
6	Q222030000	SELF-LOCK.NUT.M5	2		
7	R010534000	DOOR CLOSED SWITCH	1		
8	P620526000	DOOR BLOCKED FLAT SWITCH	1		
9	Q242010000	WASHER A.3 A304	8		
10	P620529000	UNLOCK	1		
11	R010535000	SPACER PLATE	2		
12	Q032012000	CURVED SCREW M3X15	4		
13	Q302022000	WASHER 16X6X1.2 A.304	1		
14	Q242030000	WASHER A5 A.304	1		
15	R073004000	STUFFING BOX	1		
16	P620525000	ELECTROMAGNET RING	1		
17	Q012032000	HEX BOLT M5X15 A.304	1		
18	P620520000	DOOR PULL	1		
19	Q232010000	FLAT WASHER A3,DIN125	6		
20	P623010000	DOOR WIRING	1		

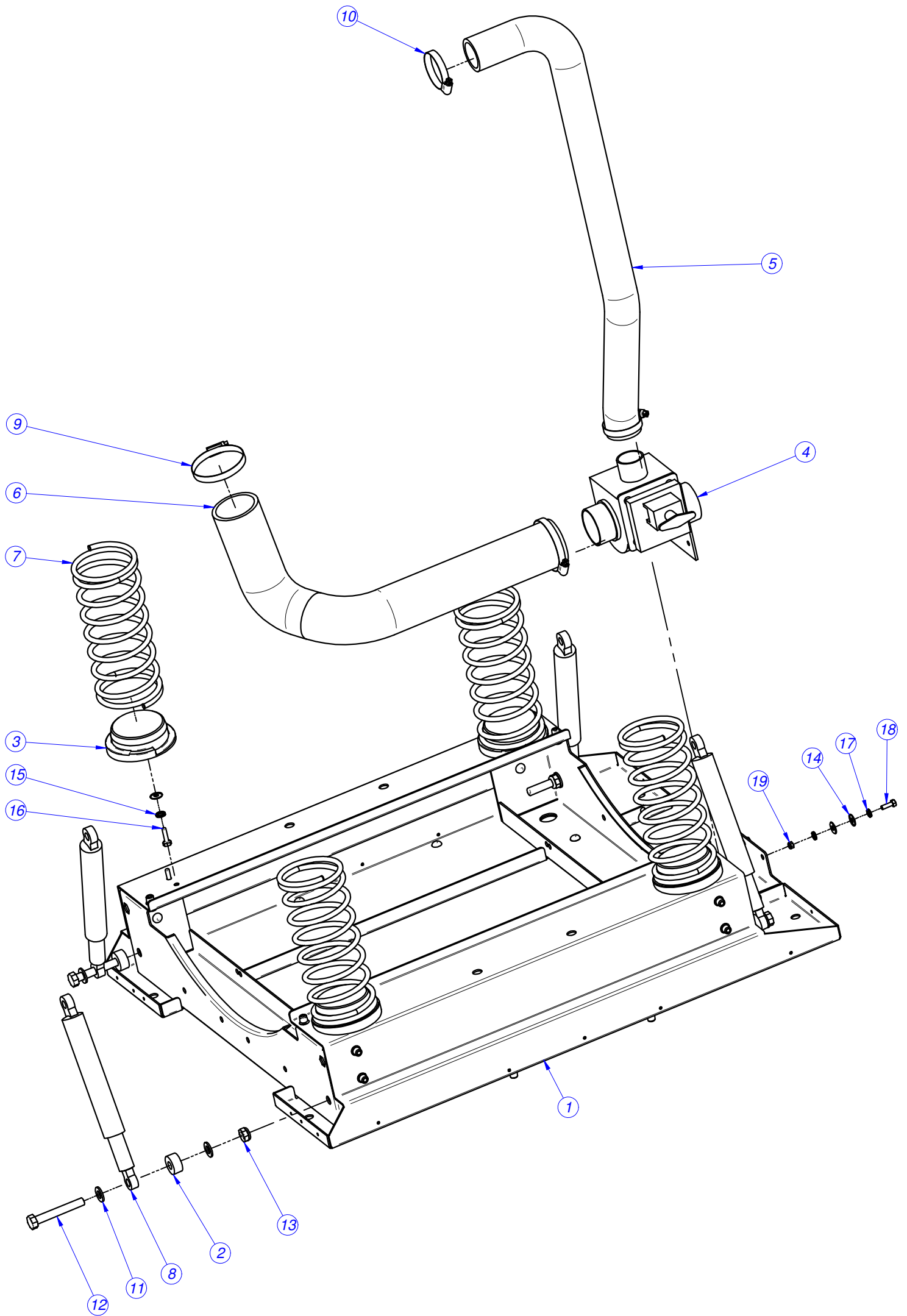

MOD.	WASHER EXTRACTOR 13		ZONA	FRAME	
Nº	CODIGO	DENOMINACION	Cant.		
1	P620104000	COMPLETE FRAME 13	1		
2	P620107000	SHOCK ABSORBER BUSHING	4		
3	P620106000	SPRING BASE	4		
4	P302120000	DRAINAGE VALVE	1		
5	P620704000	OVERFLOW PIPE 13	1		
6	P620703000	DRAIN PIPE 13	1		
7	P620105000	SPRING 13	4		
8	P620115000	SHOCK ABSORB. 120NW	4		
9	Q881324000	CLAMP 50-70L	2		
10	Q881306000	CLAMP 32-50L	2		
11	Q232060000	WASHER A10	2		
12	Q011369000	HEX.SCREW.M10X70 H.ZINC	1		
13	Q221306000	HEX.SCREW.AUT.M10 8.8 ZINC	1		
14	Q302022000	WASHER 16X6X1.2 A.304	12		
15	Q242040000	WASHER A6 A.304	8		
16	Q012043000	HEX BOLT M6X20 A.304	8		
17	Q242030000	WASHER A5 A.304	4		
18	Q012032000	HEX BOLT M5X15 A.304	2		
19	Q221308000	HEX.SCREW.AUT.M5 H.ZINC	2		

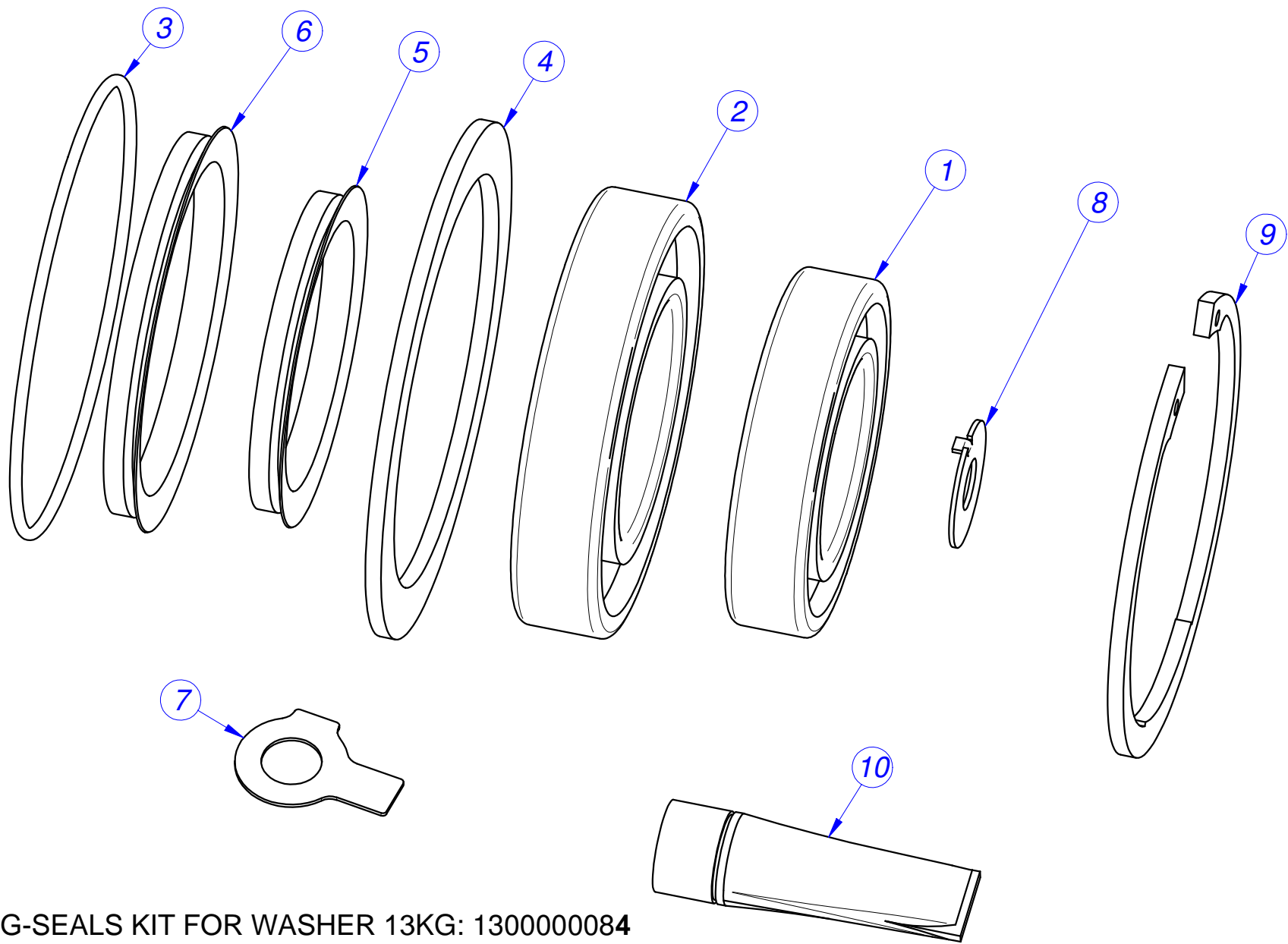

BEARING-SEALS KIT FOR WASHER 13KG: 130000084

MOD.	WASHER EXTRACTOR 13		AREA	BEARING KIT	
No	CODE	DENOMINATION	Quant.		
	1300000084	BEARING-SEALS KIT FOR WASHER 13 KG.			
		Included:			
1	P626008	BEARING 50/90/20	1		
2	P626009	BEARING 60/110/22	1		
3	Q307075	O RING GASKET 114x3	1		
4	P626007	COUNTERRETAIN SEAL 13	1		
5	P624913	V-RING RETAINER 70	1		
6	P624914	V-RING RETAINER 85	1		
7	Q271302	SECURITY WASHER 13	8		
7	Q271303	SECURITY WASHER 15	8		
8	Q301329	SECURITY WASHER 13	1		
9	Q301030	SAFET. RING SEEGER INT.90	1		
10	P536544	GREASE AMBLYGON TA 15/2	1		

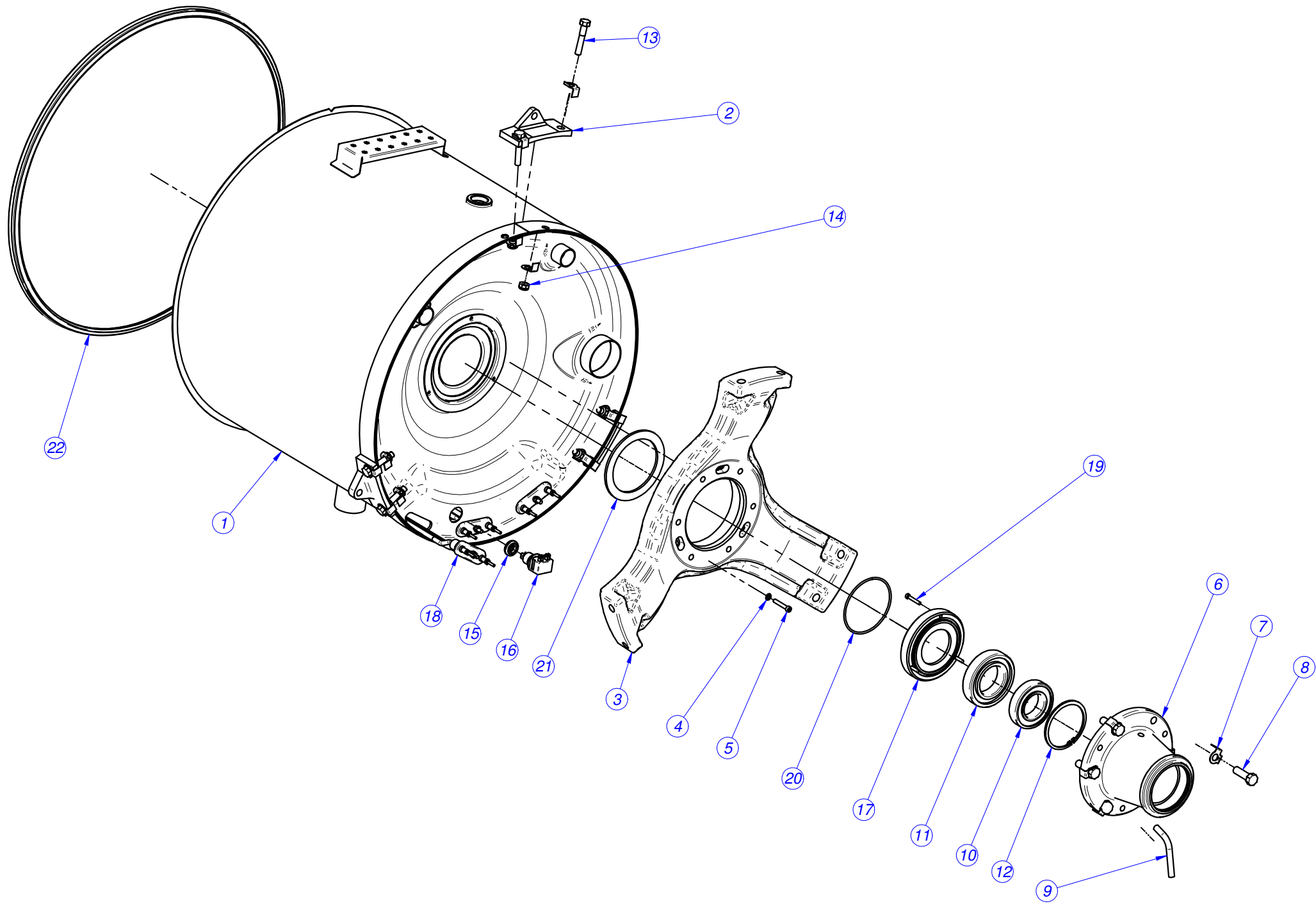

MOD.	WASHER EXTRACTOR 13		ZONA	TUB	
Nº	CODIGO	DENOMINACION	Cant.		
1	P626115000	COMPLETE TUB 13	1		
2	P626014000	BOLT SUPPORT 13	3		
3	P626001000	TUB BASE REINFORCEMENT 13	1		
4	Q232040000	WASHER A6	3		
5	Q122045000	ALLEN BOLT M6x35 INOX	3		
6	P626002000	BEARING SUPPORT 13	1		
7	Q271302000	SAFETY WASHER 13 DIN 463	18		
8	Q151529000	HEX BOLT M12x55	6		
9	P626015000	DRAINAGE PIPE	1		
10	P626008000	BEARING 6210-2Z	1		
11	P626009000	BEARING 6212-2RS1	1		
12	Q301030000	INT. SAFETY RING 90	1		
13	Q151530000	HEX BOLT M14x50 DIN 931	6		
14	Q221307000	HEX NUT AUT.M12	6		
15	Z953003000	RUBBER BUSHING FOR THERMOSTAT	1		
16	P503025000	THERMOSTAT	1		
17	P626003000	COUNTER RETAINER BUSHING 13	1		
18	P623005000	HEATING ELEMENT 3000w	3		
19	Q122034000	BOLT, ALLEN M5x30 INOX	3		
20	Q307075000	"O" RING. 114x3	1		
21	P626007000	BUSHING GASKET SEALS 13	1		
22	P626110000	TUB FRONT GASKET 13	1		

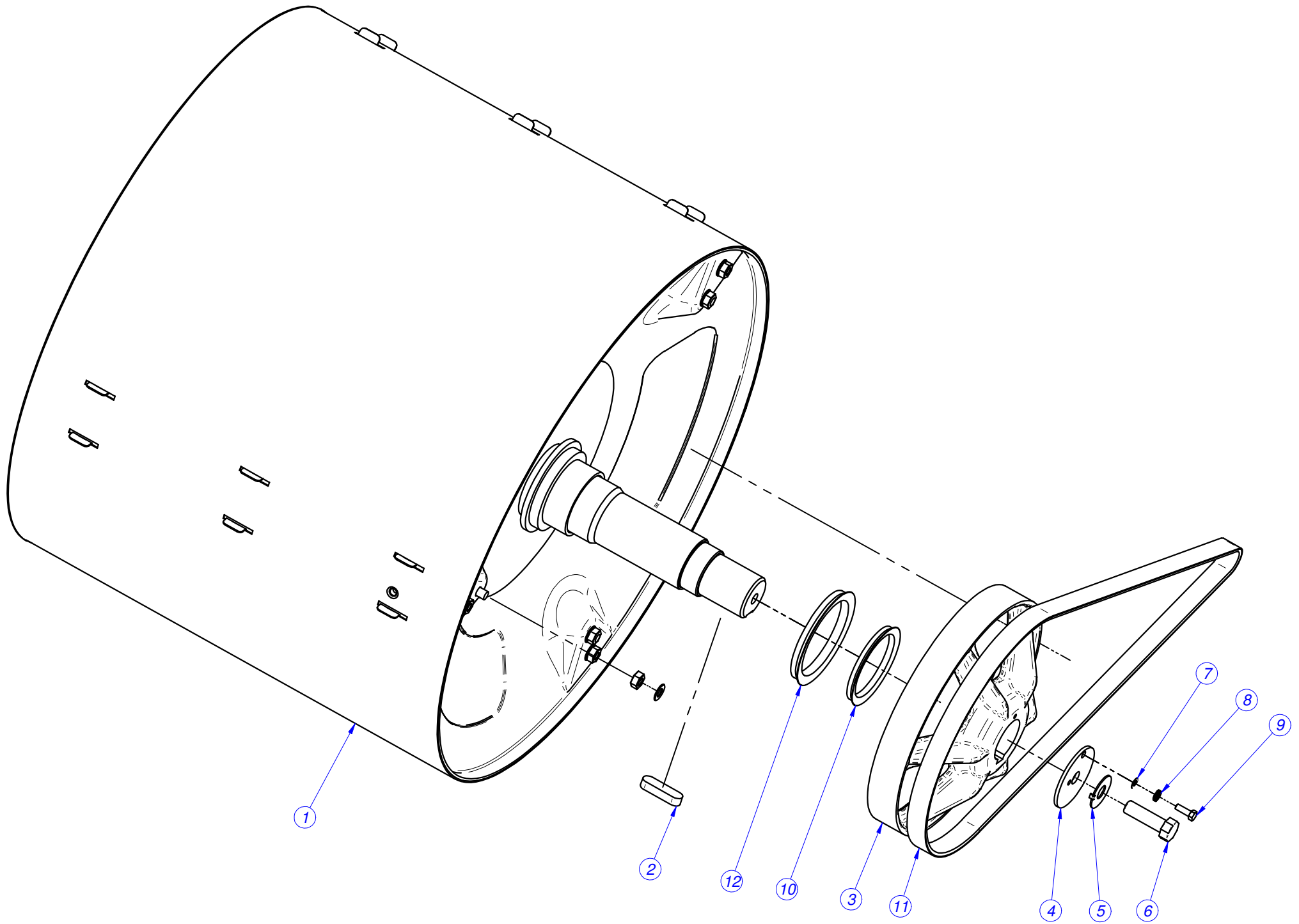

MOD.	WASHER EXTRACTOR 13		ZONA	DRUM	
Nº	CODIGO	DENOMINACION	Cant.		
1	P624909000	COMPLETE DRUM 13	1		
2	P626010000	PIN 14x9x50	1		
3	P626006000	DRUM PULLEY 13.18	1		
4	P626012000	PULLEY WASHER 13.18	1		
5	Q301329000	SAFETY WASHER 13	1		
6	Q011376000	HEX.SCREW.M12X40 H.ZINC	1		
7	Q232030000	WASHER A5	1		
8	Q242030000	WASHER A5 A.304	1		
9	Q012032000	HEX BOLT M5X15 A.304	1		
10	P624913000	V-RING RETAINER VA070	1		
11	P625903000	BELT 13	1		
12	P624914000	V-RING RETAINER VA085	1		

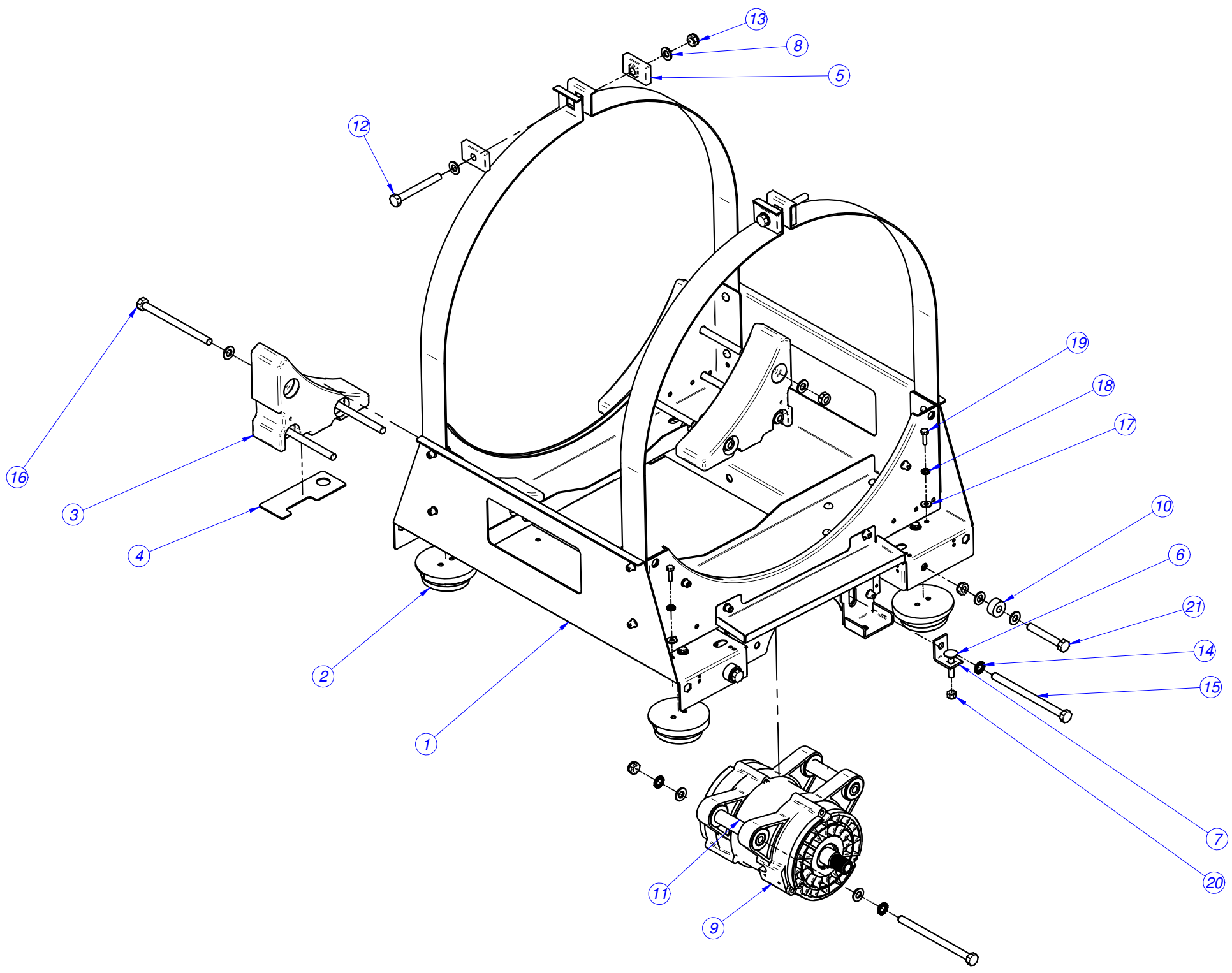

MOD.	WASHER EXTRACTOR 13		ZONA	CRADLE	
Nº	CODIGO	DENOMINACION	Cant.		
1	P620207000	COMPLETE CRADLE 13	1		
2	P620106000	SPRING BASE	4		
3	P620201000	COUNTERWEIGHT 13	4		
4	P610212000	COUNTERWEIGHT SUPPORT 8, 13	2		
5	P620208000	TUB FASTENER	4		
6	Q151393000	SCREW DIN 603 M8x35	1		
7	P620214000	MOTOR TENSOR	1		
8	Q232060000	WASHER A10	27		
9	P625905000	MOTOR 13	1		
10	P620107000	SHOCK ABSORBER BUSHING	8		
11	P625901000	MOTOR BRACKET PIPE 13	2		
12	Q011360000	HEXAGONAL SCREW M10X80	2		
13	Q221306000	HEX.SCREW.AUT.M10 8.8 ZINC	14		
14	Q241560000	WASHER A10 DIN6798	4		
15	Q151525000	HEX BOLT M10X150(8.8) DIN931	2		
16	Q151394000	HEX BOLT M10x140	6		
17	Q302022000	WASHER 16X6X1.2 A.304	8		
18	Q242040000	WASHER A6 A.304	8		
19	Q012043000	HEX BOLT M6X20 A.304	8		
20	Q221309000	HEX.SCREW.AUT.M8 8.8 ZINC	1		
21	Q011369000	HEX.SCREW.M10X70 H.ZINC	4		

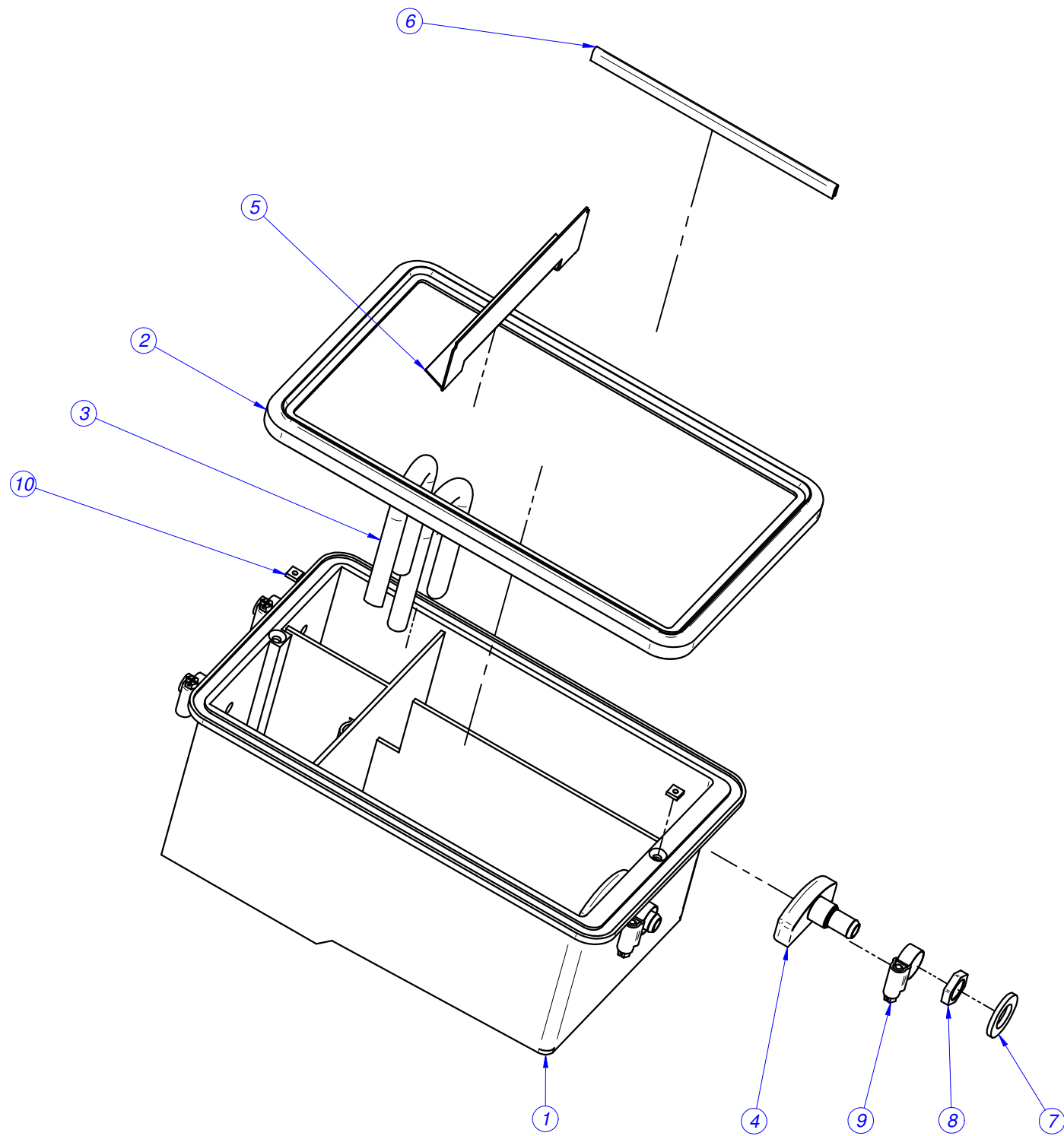

MOD.	WASHER EXTRACTOR 13		ZONA	TRAY	
Nº	CODIGO	DENOMINACION	Cant.		
1	P440700000	DETERGENT TRAY	1		
2	P500702000	TRAY JOINT 1003431	1		
3	P440702000	SIPHON PIPE	2		
4	P440701000	DETERGENT DISPERSER	2		
5	P440715000	BRACKET PROTECTION	1		
6	P440721000	REINFORCEMENT PROFILE	1		
7	Q301302000	FLAT WASHER A17	2		
8	Q223018000	NUT 16X1.5	2		
9	Q881305000	CLAMP 25-40	4		
10	Q222004000	SQUARE NUT M.4	2		

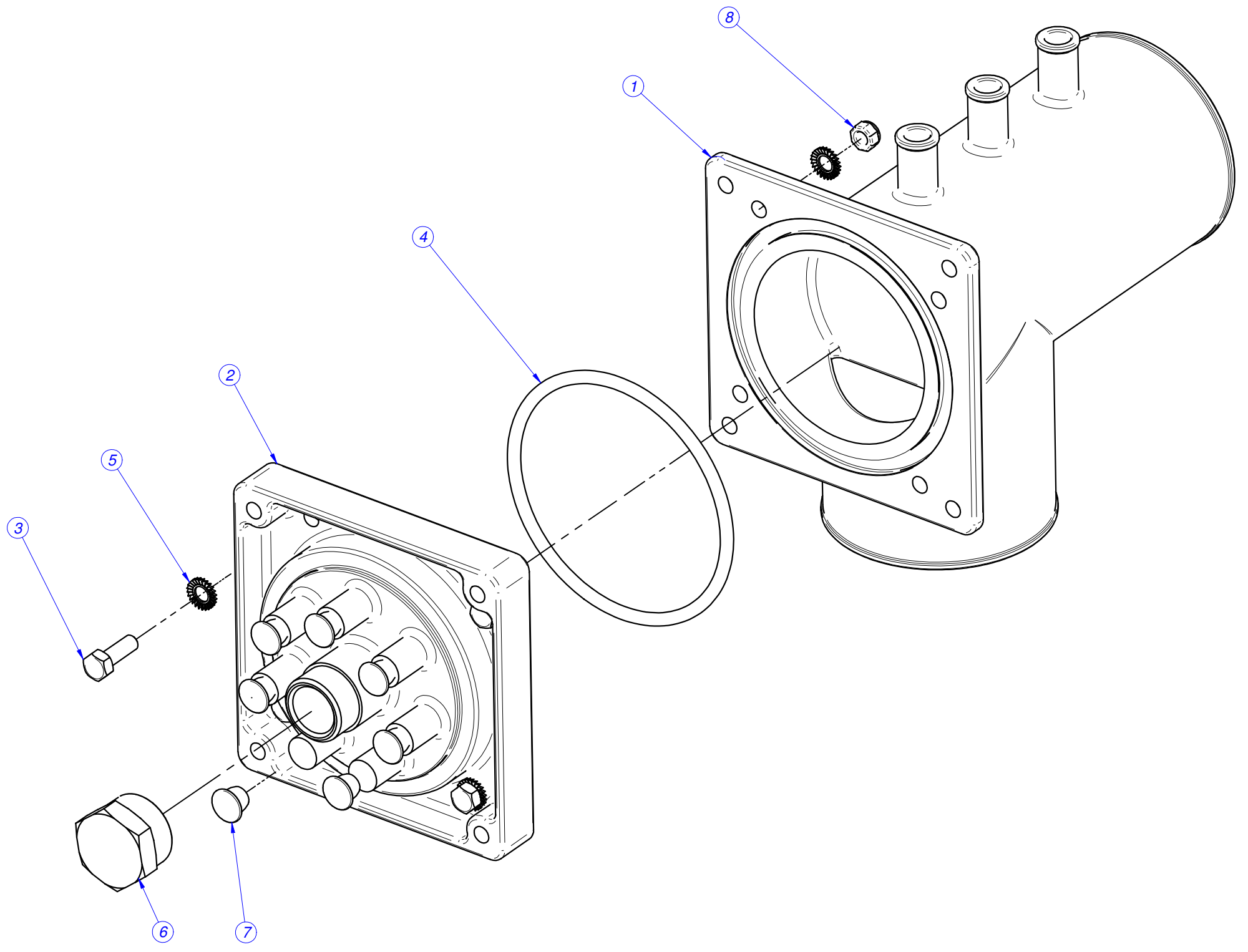

MOD.		WASHER EXTRACTOR 13		ZONA	DOSING	
Nº	CODIGO	DENOMINACION	Cant.			
	P620707000	COMPLETE DOSING	1			
1	P620701000	INT. DISPENSER INLET P	1			
2	P620706000	OUTER DOSING INLET	1			
3	Q012032000	HEX BOLT M5X15 A.304	4			
4	Q307081000	"O" RING 75x4	1			
5	Q242030000	WASHER A5 A.304	8			
6	P620710000	COVER 1/2"	1			
7	P620709000	DISPENSER PLUG	7			
8	Q222030000	SELF-LOCK.NUT.M5	4			

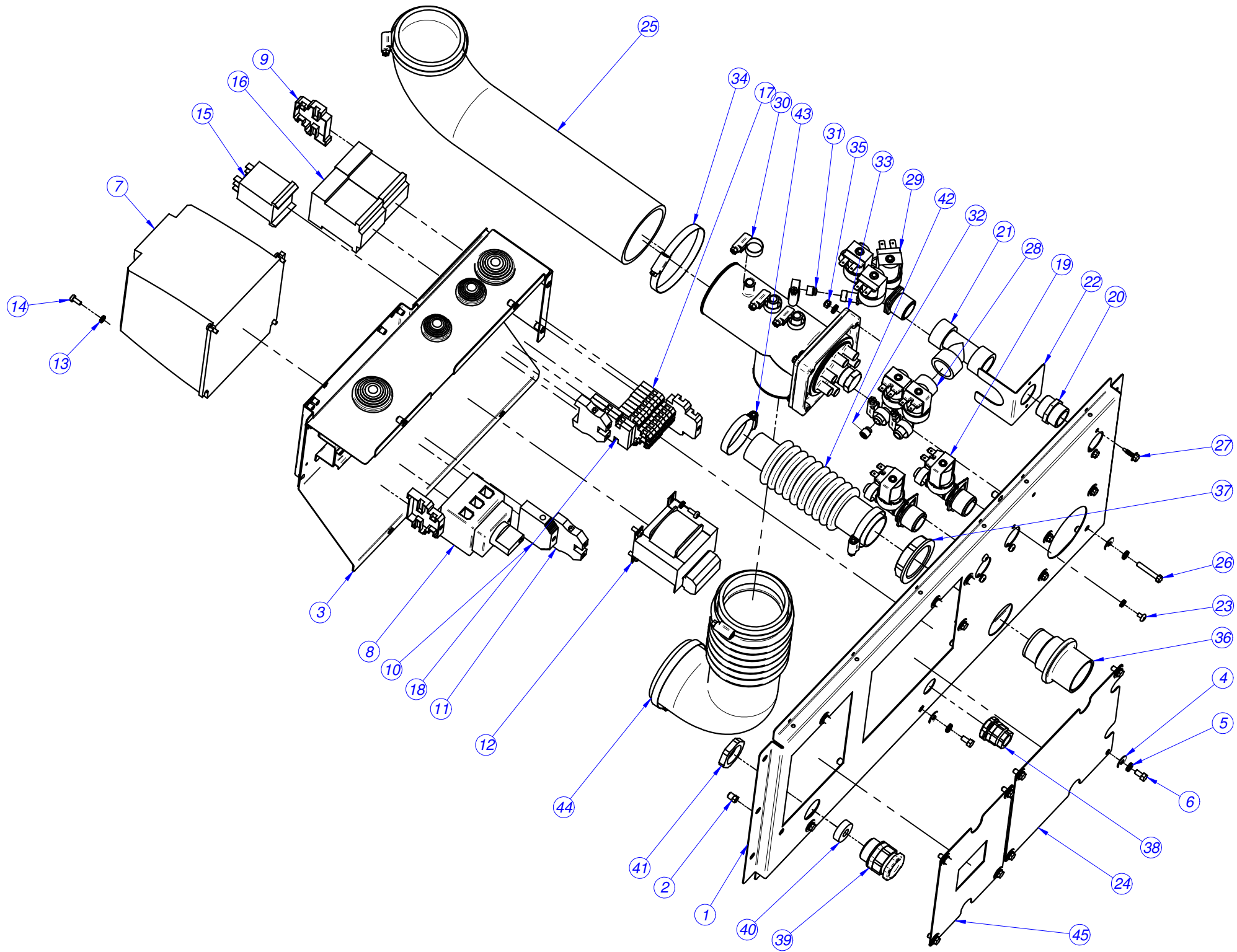

MOD.	WASHER EXTRACTOR 13		ZONA	SOLENOID SUPPORT	
Nº	CODIGO	DENOMINACION	Cant.		
1	P620331000	INLETS REAR PANEL 13 V2	1		
2	Q221342000	HEXAGONAL RIVET M5	14		
3	P620347000	SUPPLY PANEL HOLDER COMP.V2	1		
4	Q302022000	WASHER 16X6X1.2 A.304	18		
5	Q242030000	WASHER A5 A.304	22		
6	Q012031000	HEX BOLT M5X10 A.304	14		
7	P623002000	FRECUENCY INVERTER 1.5 Kw	1		
8	P623003000	SECTION SWITCH 32A	1		
9	Z263303000	END STOP	3		
10	Z263302000	BLUE THROUGH TERMINAL	1		
11	P453026000	TERMINAL TIER 10 WPE-10103.O	2		
12	P623028000	TRANSFORMER 220/20-0-20 VAC	1		
13	Q242020000	WASHER A.4 A304	12		
14	Q032021000	CURVED SCREW M4X10	8		
15	Z203062000	RELAY 230V 16A 50-60 HZ	1		
16	Z203050000	CONTAC. SIRIUS 3R 230V.50-60	2		
17	P623006000	TERMINAL STRIP 2 PISOS	8		
18	R073005000	FUSE HOLDER TERMINALS	2		
19	Z701135000	E.V.SIMP.220V COD.255.208	2		
20	Z102301000	HOSE 3/4"	1		
21	P535020000	T at 90°-3/4"	1		
22	P535003000	SOLENOID VALVE STOP	1		
23	Q151320000	CURVED SCREW.M4X6 H.ZINC	4		
24	P620342000	REAR COVER V2	1		
25	P620705000	DISPENSER TRAY PIPE 13	1		
26	Q011353000	HEXAGONAL SCREW M5X30	4		
27	Q151323000	SCREW BIT 4.8X16	2		
28	P255001000	DOUBLE SOLENOID VALVE	1		
29	Z611123000	TRIPLE SOLENOID VALVE	1		
30	Q881302000	CLAMP 12-20	10		
31	P443042000	REGULATOR 3L NE.254,023	1		
32	Z601156000	REGULATOR 8L RED 254.034	1		
33	P620707000	COMPLETE DOSING INLET	1		
34	Q881326000	CLAMP 70-90	4		
35	Q222030000	SELF-LOCK.NUT.M5	4		
36	Z740701000	STEAM VACUMM PLASTIC PIPE	1		
37	Z710708000	WALL BUSHING NUT	1		
38	R073004000	STUFFING BOX	1		
39	R023013000	STUFFING BOX PG-21	1		
40	R023026000	RUBBER SEAL (GAES)	1		
41	Q223016000	SCREW THREAD Pg 21	1		
42	P620708000	STEAM OUTLET PIPE	1		
43	Q881306000	CLAMP 32-50L	2		
44	P620702000	TUB DISPENSER PIPE 13	1		
45	P620341000	CIRCUIT BREAKER COVER V2	1		

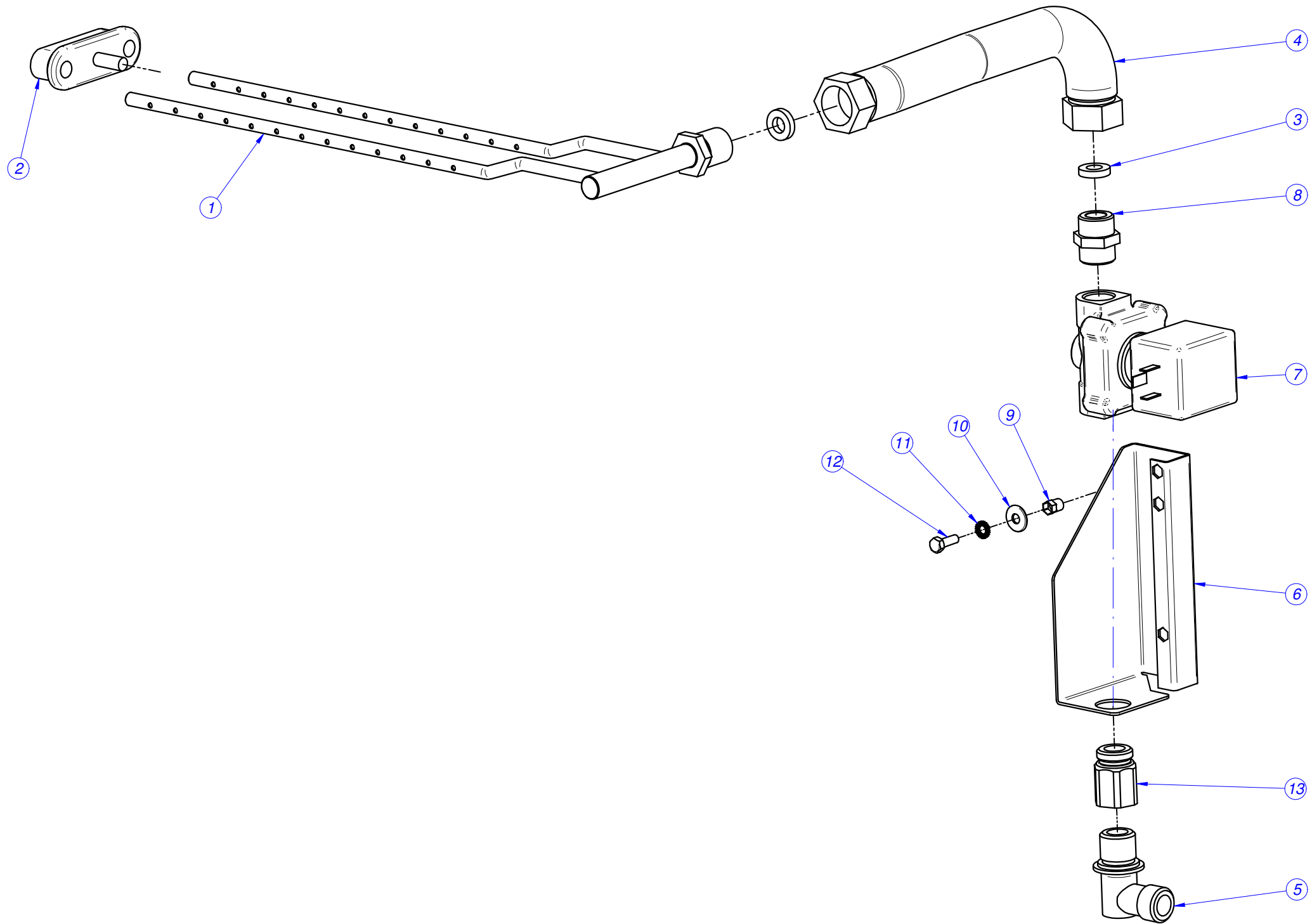

MOD.	WASHER EXTRACTOR 13		ZONA	STEAM	
Nº	CODIGO	DENOMINACION	Cant.		
1	P615001000	STEAM JET 10,13,18	1		
2	P445011000	COMPLETE LOCK	1		
3	P615002000	STEAM WASHER 10,13,18	2		
4	P525005000	STEAM PIPE	1		
5	S115013000	BRASS ELBOW	1		
6	P620327000	STEAM VALVE BRACKET	1		
7	P505012000	STEAM VALVE 1/2" 50/60 Hz	1		
8	S205023000	DOUBLE SLEEVE 1/2	1		
9	Q221342000	HEXAGONAL RIVET M5	1		
10	Q302022000	WASHER 16X6X1.2 A.304	1		
11	Q242030000	WASHER A5 A.304	1		
12	Q012032000	HEX BOLT M5X15 A.304	1		
13	X162101000	CONNECTION 1-2	1		

Referencias cableados LA-13 M
Wires reference LA-13 M

<i>TEXTO</i>	<i>CODIGO</i>	<i>CANTIDAD</i>
<p><i>Cableado general (incluye cableado motor)</i></p> <p><i>General electric wiring (Included the motor wire)</i></p>	<i>P623007</i>	<i>1</i>
<p><i>Cableado resistencias.</i></p> <p><i>Heating elements wire.</i></p>	<i>P623008</i>	<i>1</i>
<p><i>Cableado plano tarjeta reles a tarjeta display M.</i></p> <p><i>Display card-Relay card wire.</i></p>	<i>P633026</i>	<i>1</i>
<p><i>Cableado puerta. Door device wire.</i></p>	<i>P623010</i>	<i>1</i>
<p><i>PTC alimentación bobina cierre.</i></p> <p><i>PTC supply coil door.</i></p>	<i>P643005</i>	<i>1</i>

(380-480)V 3/3N ~

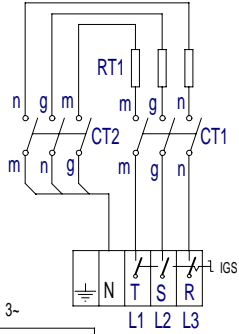

200....230 V 3~

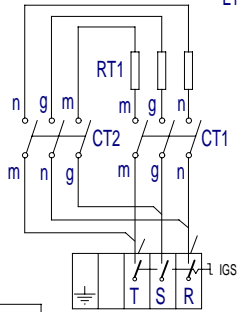

(200=230)V 1N~

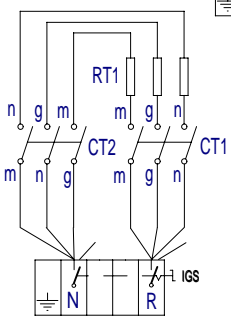

(380-480)V3~

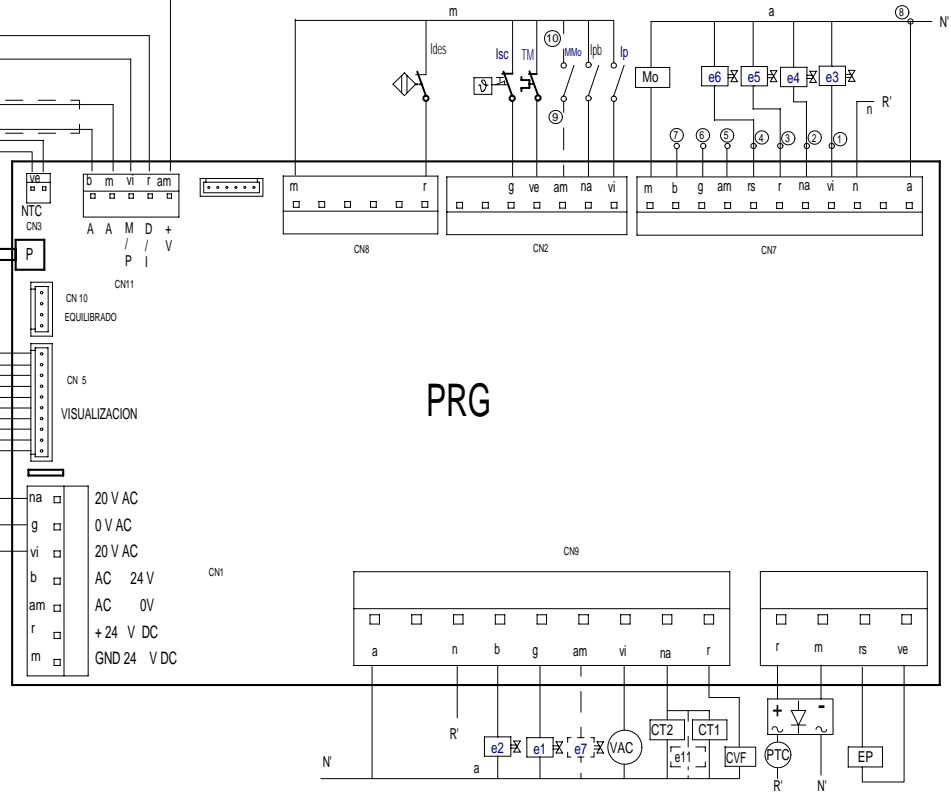
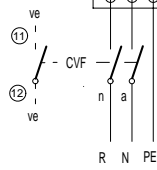
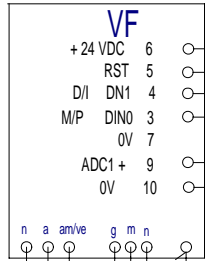
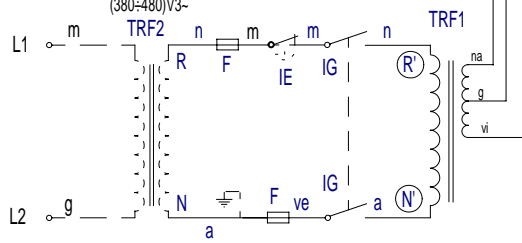

P623013000

Simb / LENG	ESPAÑOL	FRANÇAIS	ENGLISH	DEUTSCH	ITALIANO
CT =	Contacto Calentamiento	Contacteur Chauffe	Heating Contactor	Heizschütz	Contatore Riscaldamento
DP =	Detector posición.	Détecteur position	Position detector	Stellung Taster	Rilevatore posizione
DS1	Dosificador Neutralizante.	Doseur Neutralisant	Neutralizer feeder	Dosiervorrichtung Neutralpulmittel	Dosatore Neutralizzante
DS2	Dosificador jabon liquido.	Doseur lessive liquide	Liquid soap feeder	Dosiervorrichtung Flüssigseife	Dosatore sapone liquido
DS3	Dosificador aditivos.	Doseur additifs	Additive feeder	Dosiervorrichtung Zusatzmittel	Dosatore additivi
D.T.	Display/Teclado	Ecran/Clavier	Display/Keyboard	Display/Tastatur	Display/Tastiera
e1 =	Electro válvula agua Fria.	Électrovanne eau Froide	Cold water electrically operated valve	Elektroventil Kaltwasser	Elettrovalvola acqua Fredda
e2 =	Electro válvula agua Caliente	Électrovanne eau Chaude	Hot water electrically operated valve	Elektroventil Warmwasser	Elettrovalvola acqua Calda
e3 =	Electro válvula Prelavado.	Électrovanne Prélavage	Pre-wash electrically operated valve	Elektroventil Vorwaschen	Elettrovalvola Prelavaggio
e4 =	Electro válvula Lavado.	Électrovanne Lavage	Wash electrically operated valve	Elektroventil Hauptwaschgang	Elettrovalvola Lavaggio
e5 =	Electro válvula Lejia.	Électrovanne Eau de Javel	Bleach electrically operated valve.	Elektroventil Bleiche	Elettrovalvola Candeggina
e6 =	Electro válvula Suavizante.	Électrovanne Assouplissant	Fabric softener electrically operated valve	Elektroventil Weichspüler	Elettrovalvola Ammorbidente
e7 =	Electro válvula agua Descalcificada	Électrovanne eau Adoucie	Delimed water electrically operated valve	Elektroventil entkalktes Wasser	Elettrovalvola acqua Decalcificata
e8 ,9,10 =	Electro válvula Equilibrado	Électrovanne Équilibrage	Balancer electrically operated valve	Elektroventil Gleichgewicht	Elettrovalvola Bilanciamento
e11 =	Electro válvula Vapor.	Électrovanne Vapeur	Steam electrically operated valve	Elektroventil Dampf	Equilibrado Vapore
EP =	Electroímán de Puerta.	Électro-aimant de Porte	Door electric magnet	Elektromagnet Gerätetür	Elettromagnete Porta
FI =	Filtro de Interferencias.	Filtre Anti-parasites	Interference filter	Störungsfilter	Filtro Interferenze
F =	Fusible.	Fusible	Fuse	Sicherung	Fusibile
G1,G2 =	Galga Sensor.	Jauge Capteur	Sensing gage	Meßsensor	Calibro Sensore
IE =	Pulsador Parada de emergencia.	Bouton-poussoir Arrêt d'urgence	Emergency stop push button	Not-Aus-Taster	Pulsante Arresto di emergenza
IG =	Interruptor general.	Interrupteur général	General switch	Hauptschalter	Interruttore generale
IGS =	Interruptor General de seguridad.	interrupteur Général de sécurité	General safety switch	Sicherheitshauptschalter	Interruttore Generale di sicurezza
Ides =	Interruptor de desequilibrio.	Interrupteur de balourd	Unbalance switch	Ungleichgewichtsschalter	Interruttore di squilibrio
IMo =	Interruptor Monedero.	Interrupteur Monnayeur	Coin slot switch	Münzschalter	Interruttore Portamonete
Ip =	Interruptor puerta Cerrada.	Interrupteur porte Fermée	Closed door switch	Schalter Tür geschlossen	Interruttore porta Chiusa
Ipb =	Interruptor puerta bloqueada.	Interrupteur porte verrouillée	Door lock switch	Schalter Tür verriegelt	Interruttore porta bloccata
Isc	Interruptor seguridad Temperatura	Thermostat Limiteur	Hi-limit Thermostat	Grenzthermostat	Termostato Limitatore
M =	Motor.	Moteur	Motor	Motor	Motore
Mo =	Monedero.	Monnayeur	Coin slot	Münzvorrichtung	Portamonete
NTC =	Sensor temperatura..	Capteur température	Temperature sensor	Temperatursensor	Sensore temperatura
RT =	Resistencia Calentamiento.	Résistance Chauffe	Heating Resistors	Widerstand Aufheizung	Resistenza Riscaldamento
Tm =	Térmico de Motor.	Thermique du Moteur	Motor hot-wire	Motorwärmeschalter	Termico del Motore
Tfr =	Transformador	Transformateur	Transformer	Transformator	Trasformatore
Tfr s/N =	Transformador Versión sin Neutro.	Transformateur Version sans Neutre	Transformer Version without Neutral	Transformator Modell ohne Neutralstellung	Trasformatore Versione senza Neutro
VAC =	Válvula Vaciado	Vanne Vidange	Emptying valve	Ablassventil	Valvola Scarico
Ve =	Ventilador.	Ventilateur	Fan	Ventilator	Ventola
VF =	Convertidor de Frecuencia.	Convertisseur de Fréquence	Frequency converter	Frequenzumwandler	Convertitore di Frequenza
VM =	Ventilador Motor.	Ventilateur Moteur	Fan motor	Ventilator Motor	Ventola Motore
1...8 =	Puntos conexión dosificadores.	Points raccordement doseurs	Feeder connection points	Anschlussstellen Dosiervorrichtungen	Punti connessione dosatori
COLOR	COLORES	COULEURS	COLOUR	FARBEN	COLORE
a =	Azul	Bleu	Blue	Blau	Blu
am =	Amarillo	Jaune	Yellow	Gelb	Giallo
am/ve =	Amarillo/Verde	Jaune / vert	Yellow / green	Gelb/grün	Giallo/verde
b =	Blanco	Blanc	White	Weiß	Bianco
g =	Gris	Gris	Grey	Grau	Grigio
m =	Marrón	Marron	Brown	Braun	Marrone
n =	Negro	Noir	Black	Schwarz	Nero
na =	Naranja	Orange	Orange	Orange	Arancio
r =	Rojo	Rouge	Red	Rot	Rosso
rs =	Rosa	Rose	Pink	Rosa	Roseo
ve =	Verde	Vert	Green	Grün	Verde
vi =	Violeta	Violet	Purple	Violett	Viola