



Geschirrspülmaschinen

Warewashers

Machines à laver la vaisselle



CS / CN / CP

**ERSATZTEILE
SPARE PARTS
PIECES DETACHEES**

Ab Serien-Nummer:
Starting from Serial No.:
A partir du no. de série:

CN/CP	Protronic	- 86 68 00001 / DSN: CN-09-02
CN	Smartronic	- 86 67 00001 / DSN: CN-09-02
CS	Easytronic	- 8643 6001

REV. 11.10.2012

Die in diesem Katalog aufgeführten Elektroteile beziehen sich auf folgende Anschluss-Spannungen:
Electrical components listed in this catalogue are rated for the following supply voltages:
Les composants électriques énumérés dans ce catalogue sont prévus pour les tensions suivantes:

400V / 50Hz / 3 / PE

Bei nicht aufgeführten Anschluss-Spannungen bitte den, der Maschine beigelegten Schaltplan beachten.

For other voltages, refer to the wiring diagram shipped with the machine.

Pour d'autres tensions, se référer au schéma électrique envoyé avec la machine.

	ERKLÄRUNG	LEGEND	LEGENDE
1	Verschleißteile	Wearing parts	Pièces d'usure
1	Betriebswichtige Ersatzteile	Recommended spare parts	Pièces de rechange pour maintenance
(L / R)	Laufrichtung links / rechts	Operation direction left / right	Sens de marche gauche / droite
(R / L)	Laufrichtung rechts / links	Operation direction right / left	Sens de marche droite / gauche
BSP	Besteckspurbreite	Cutlery track width	Largeur de la piste des couverts

Inhalt	Kapitel
Hauben	01
E Vorwaschung	02
L Vorwaschung	03
S/A Vorwaschung	04
C Vorwaschung	05
AR/AN Waschung	06
ND Modul	07
Spülmodul	08
Trennmodul	09
Waschsystem	10
Erhitzer	11
Spülsystem	12
Füllsystem	13
Wärmerückgewinnung	14
Wärmepumpe	15
Transportsystem	16
Türen und Verkleidungen	17
Trocknung – gerade	18
Transportkurven	19
Dampfverrohrung	20
CAF Eckeinschub	21
Tischendschalter	22
Vorhänge	23

Content	Chapter
Hoods	01
E prewash	02
L prewash	03
S/A prewash	04
C prewash	05
AR/AN wash	06
ND Module	07
Rinse module	08
Disconnecting module	09
Wash system	10
Booster	11
Rinse system	12
Filling system	13
Heat recovery	14
Heat pump	15
Transport system	16
Doors and panels	17
Dryer – straight	18
Transport curves	19
Steam piping	20
CAF corner guiding	21
Table end switch	22
Curtains	23

Sommaire	Chapitre
Capots	01
E prélavage	02
L prélavage	03
S/A prélavage	04
C prélavage	05
AR/AN lavage	06
ND Module	07
Module de rinçage	08
Module de passage	09
Système de lavage	10
Chaudière	11
Système de rinçage	12
Système de remplissage	13
Récupération de la chaleur	14
Pompe à chaleur	15
Système de convoyage	16
Portes et panneaux	17
Séchage – droit	18
Convoyage d'angle.....	19
Tuyauterie vapeur.....	20
CAF guidage sur angle.....	21
Interrupteur fin-de-course de table	22
Rideaux	23

CS / CN / CP

Hauben

Hoods

Capots

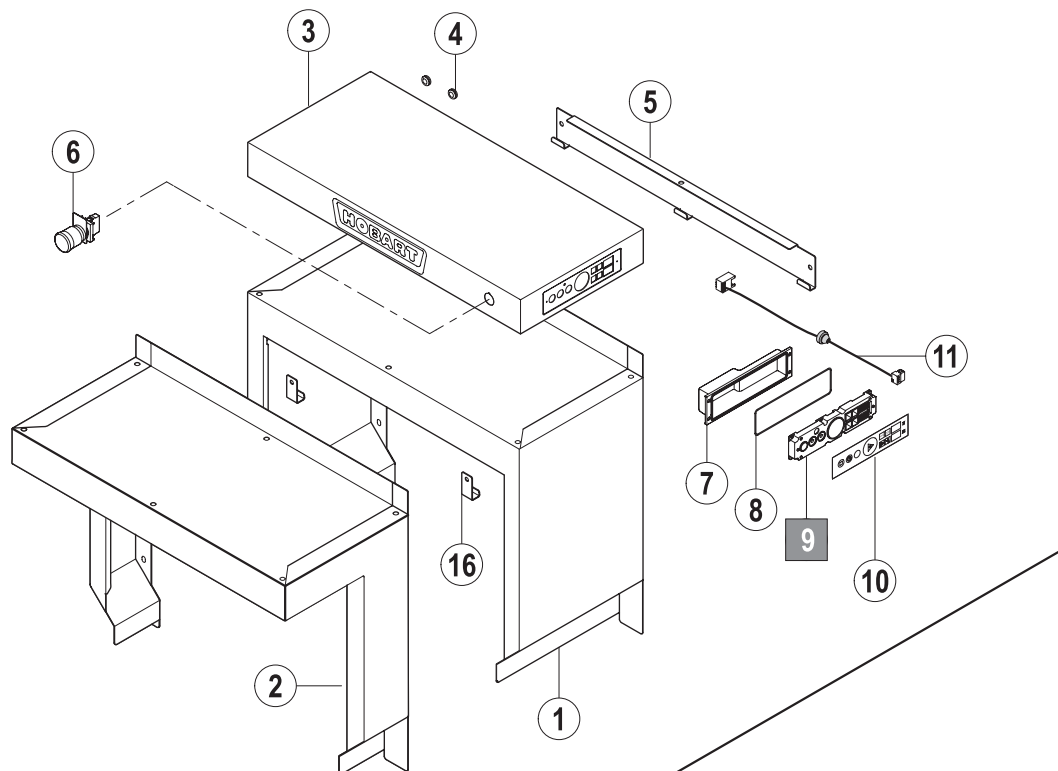

Zulauf
 Loading section
 Zone d'entrée

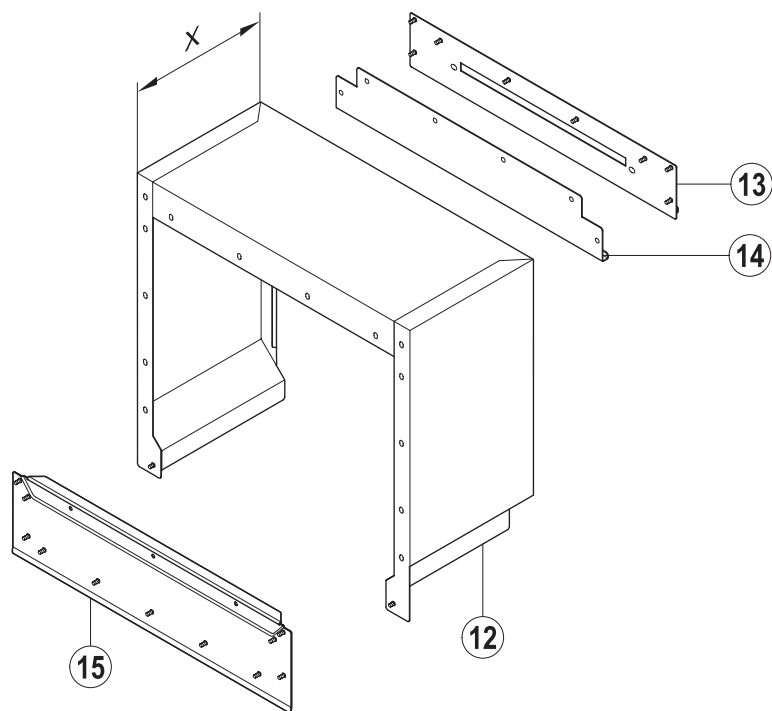

Auslauf
 Unload section
 Zone de déchargement



A Laufrichtung
Working direction
Sens de marche

B Maschinen-Grundtyp
Basic machine
Machine de base

X Länge
Length
Longueur

Pos.	A	B			X [mm]	Bemerkung / Remarks / Remarques
		CS	CN	CP		
01		---	01-291402-001	---		
02		---	01-291502-001	---		
03	L/R	---	01-291406-001	---		
	R/L	---	01-291406-002	---		
04		---	00-227748-001	---		
05		---	01-291538-002	---		
06		01-291707-001	=	=		
07		---	01-296387-001	---		
08		---	00-883805-001	---		
09		---	00-897540-001	---		
10		---	01-291845-001	---		
11		---	01-249757-001	---		
12		---	01-291404-001	=	300	
		01-291404-003	01-291404-002	01-291404-002	110	
13		01-291434-001	=	=		
14		01-291538-001	=	=		
15		01-291429-001	=	=		
16		---	01-291508-001	---		

CS / CN / CP

E Vorwaschung

E prewash

E prélavage

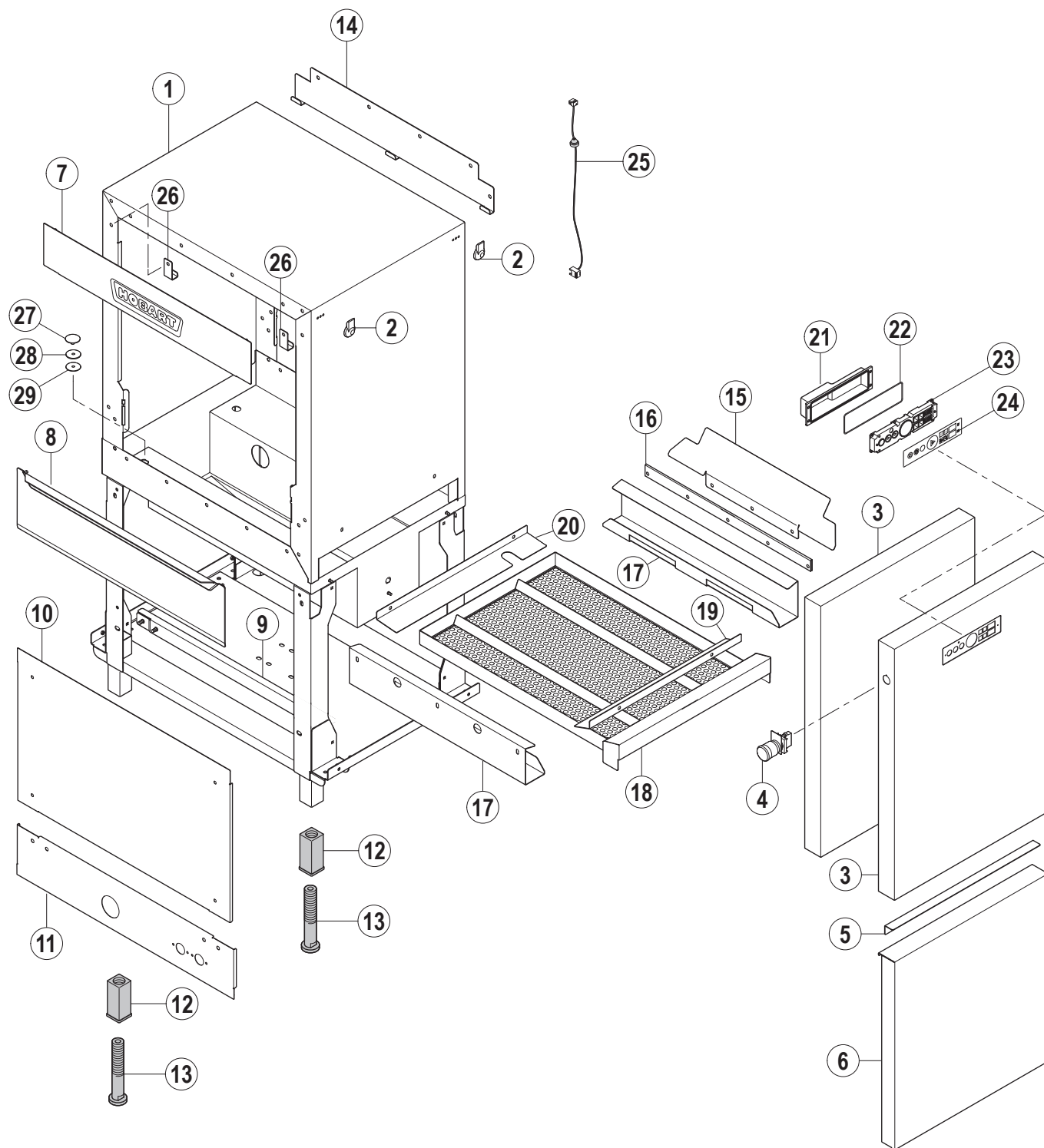



A Laufrichtung
Working direction
Sens de marche

B Maschinen-Grundtyp
Basic machine
Machine de base

X Länge
Length
Longueur

Pos.	A	B			X [mm]	Bemerkung / Remarks / Remarques
		CS	CN	CP		
01	L/R	01-291558-003	01-291558-001	01-291558-001		
	R/L	01-291558-004	01-291558-002	01-291558-002		
02		00-325037-001	00-325037-001	00-325037-001		
03	L/R	01-291488-006	01-291488-001	01-291488-005		
	R/L	01-291488-006	01-291488-002	01-291488-005		
04		01-291707-001	=	=		
05		00-896335-001	=	=		
06		01-291785-001	=	=		
07		01-291497-001	=	=		
08		01-291429-001	=	=		
09		01-291432-001	=	=		
10		01-291409-002	=	=		
11	L/R	01-291408-001	=	=		
	R/L	01-291408-002	=	=		
12		00-325008-001	=	=		
13		00-325007-001	=	=		
14		01-291538-001	=	=		
15		00-896430-003	=	=		
16		00-325155-003	=	=		
17		01-291783-001	=	=		
18		01-291782-001	=	=		ohne Magnet / without magnet / sans aimant
		---	01-291782-004	=		mit Magnet / with magnet / avec aimant
19		01-291784-001	=	=		
20	L/R	01-291784-002	=	=		
	R/L	01-291784-003	=	=		
21		---	01-296387-001	---		
22		---	00-883805-001	---		
23		---	00-897540-001	---		
24		---	01-291845-001	---		
25		---	01-249757-001	---		
26		01-291508-001	=	=		
27		00-869137-003	=	=		
28		00-168611-024	=	=		
29		00-696943-030	=	=		

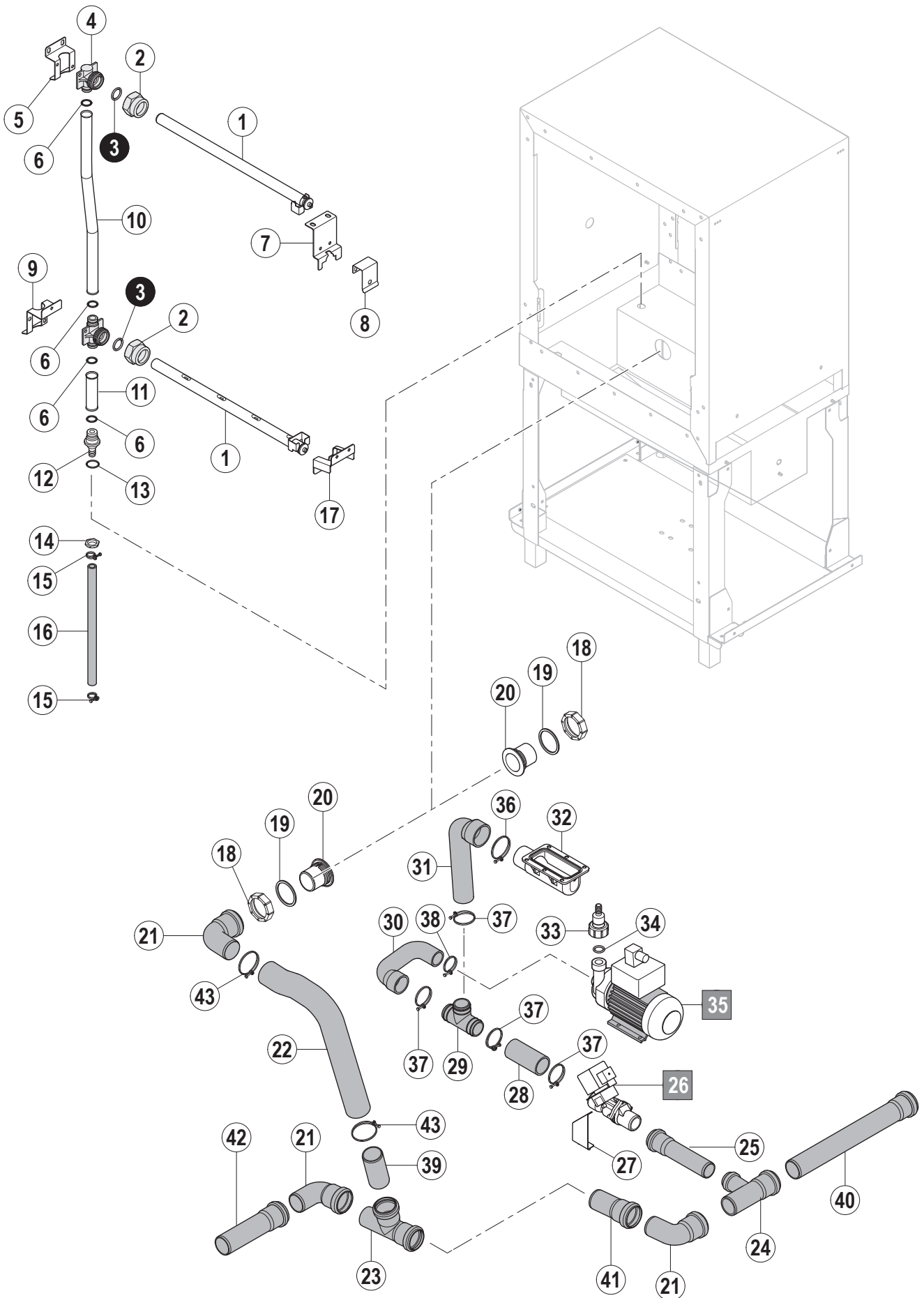

Pos.	A	B			X [mm]	Bemerkung / Remarks / Remarques
		CS	CN	CP		
01		01-291307-001	=	=		
02		00-885572-001	=	=		
03		00-884505-002	=	=		
04		01-245318-002	=	=		
05		01-291337-001	=	=		
06		01-245340-001	=	=		
07		01-291495-001	=	=		
08		01-245062-001	=	=		
09		01-291341-001	=	=		
10		01-245323-003	=	=		
11		01-291297-003	=	=		
12		01-245329-001	=	=		
13		01-245340-002	=	=		
14		00-172739-009	=	=		
15		00-323945-022	=	=		
16		01-245571-014	=	=		
17		01-291494-001	=	=		
18		01-245165-001	=	=		
19		01-245460-001	=	=		
20		01-245112-001	=	=		
21		00-230080-001	=	=		
22		01-291519-001	=	=		
23		00-230079-001	=	=		
24		00-323593-002	=	=		
25		00-325706-011	=	=		
26		00-774683-...	=	=		siehe Schaltplan / see wiring diagram / voir schéma de câblage
27		01-291686-001	=	=		
28		01-291525-002	=	=		
29		01-291562-001	=	=		
30		01-291691-001	=	=		
31		01-242108-002	=	=		
32		00-325529-001	=	=		
33		00-895735-001	=	=		
34		00-067500-072	=	=		
35		00-781237-...	=	=		siehe Schaltplan / see wiring diagram / voir schéma de câblage
36		00-323945-064	=	=		
37		00-323945-053	=	=		
38		00-323945-043	=	=		
39		00-325737-007	=	=		
40		00-229679-005	=	=		
41		00-229679-013	=	=		
42		00-600569-000	=	=		
43		00-323945-068	=	=		

CS / CN / CP

L Vorwaschung

L prewash

L prélavage

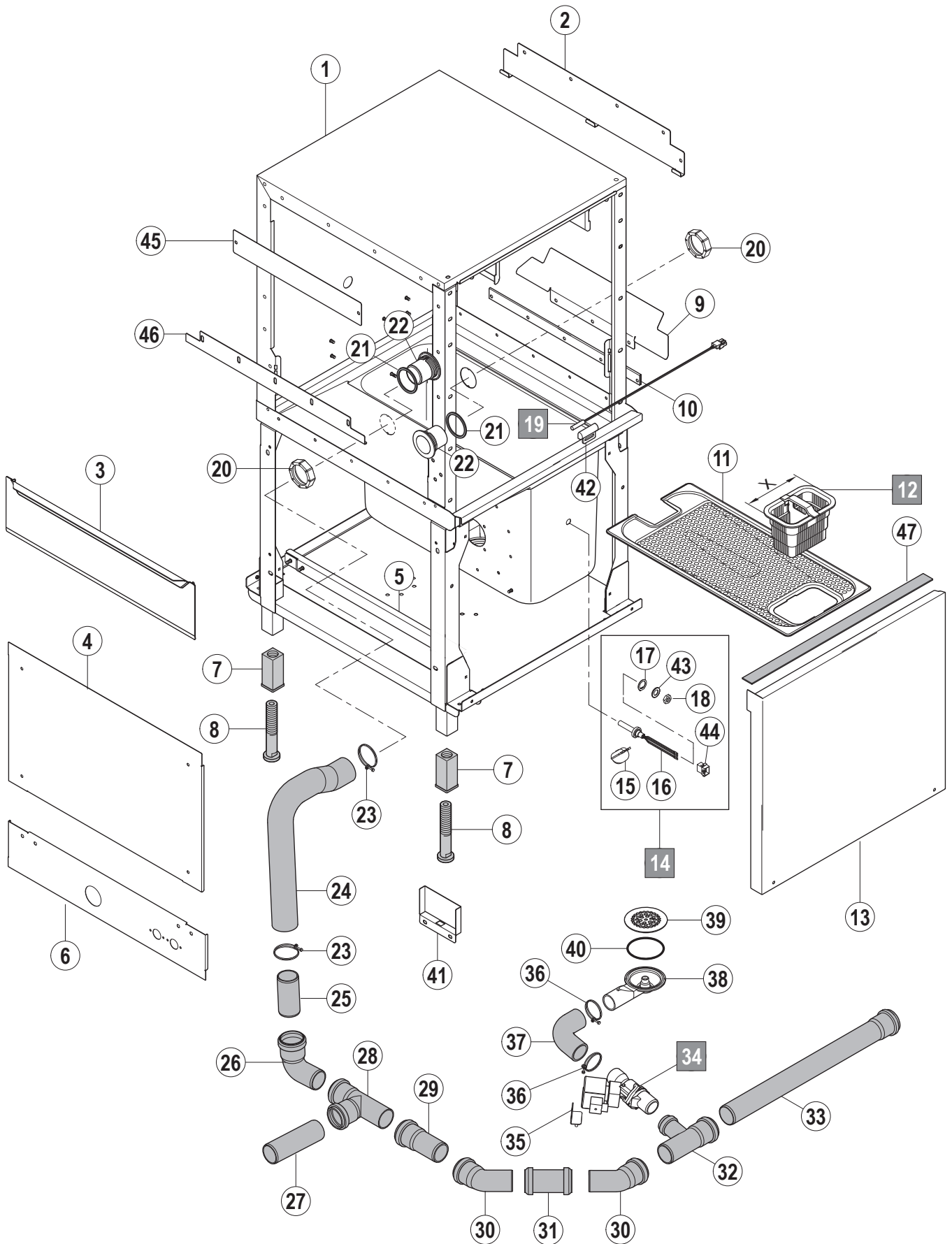

Pos.	A	B			X [mm]	Bemerkung / Remarks / Remarques
		CS	CN	CP		
01	L/R	---	01-291705-002	=		
	R/L	---	01-291705-001	=		
02		---	01-291538-001	=		
03		---	01-291429-001	=		
04		---	01-291409-001	=		ohne ASR / without ASR / sans ASR
		---	01-291409-006	=		mit ASR / with ASR / avec ASR
05		---	01-291432-001	=		
06	L/R	---	01-291408-001	=		
	R/L	---	01-291408-002	=		
07		---	00-325008-001	=		
08		---	00-325007-001	=		
09		---	00-896430-003	=		
10		---	00-325155-003	=		
11		---	01-291289-001	=		Mit / With / Avec 01-291515-001 / 01-245867-004
		---	01-291289-002	=		Mit / With / Avec 01-291515-002 / 01-245867-008
12		---	01-291515-001	=	176	Kunststoff / Plastic / Plastique
		---	01-291515-002	=	246	Kunststoff / Plastic / Plastique
		---	01-291515-004	=	246	Kunststoff mit Magnet / plastic with magnet / plastique avec aimant
		---	01-245867-004	=	176	Edelstahl / Stainless steel / Acier inoxydable
		---	01-245867-008	=	246	Edelstahl / Stainless steel / Acier inoxydable
	---	01-245867-010	=	246	Edelst. mit Magnet / stainl. steel with magnet / Acier inoxydable avec aimant	
13	L/R	---	01-291407-006	=		
	R/L	---	01-291407-007	=		
14		---	01-245621-002	=		
15		---	00-122674-000	=		
16		---	01-296000-001	=		
17		---	00-112467-000	=		
18		---	00-602476-000	=		
19		---	01-240288-001	=		
20		---	01-245165-001	=		
21		---	01-245460-001	=		
22		---	01-245112-001	=		
23		---	00-323945-064	=		
24		---	01-291519-001	=		
25		---	00-325737-007	=		
26		---	00-230080-001	=		
27		---	00-325737-004	=		
28		---	00-230079-001	=		
29		---	00-229679-013	=		
30		---	00-377340-001	=		
31		---	00-229680-001	=		
32		---	00-323593-002	=		
33		---	00-600571-000	=		
34		---	00-774683-...	=		siehe Schaltplan / see wiring diagram / voir schéma de câblage
35		---	01-291684-002	=		
36		---	00-323945-053	=		
37		---	01-291527-002	=		
38		---	01-245109-001	=		
39		---	01-245107-001	=		

A Laufrichtung
Working direction
Sens de marche

B Maschinen-Grundtyp
Basic machine
Machine de base

X Länge
Length
Longueur

Pos.	A	B			X [mm]	Bemerkung / Remarks / Remarques
		CS	CN	CP		
40		---	01-245340-004	=		
41		---	01-291982-001	=		
42		---	00-883838-001	=		
43		---	00-168611-021	=		
44		---	00-174994-013	---		
45		---	01-291197-004	---		
46		---	00-896394-001	=		
47		---	01-296451-003	=		

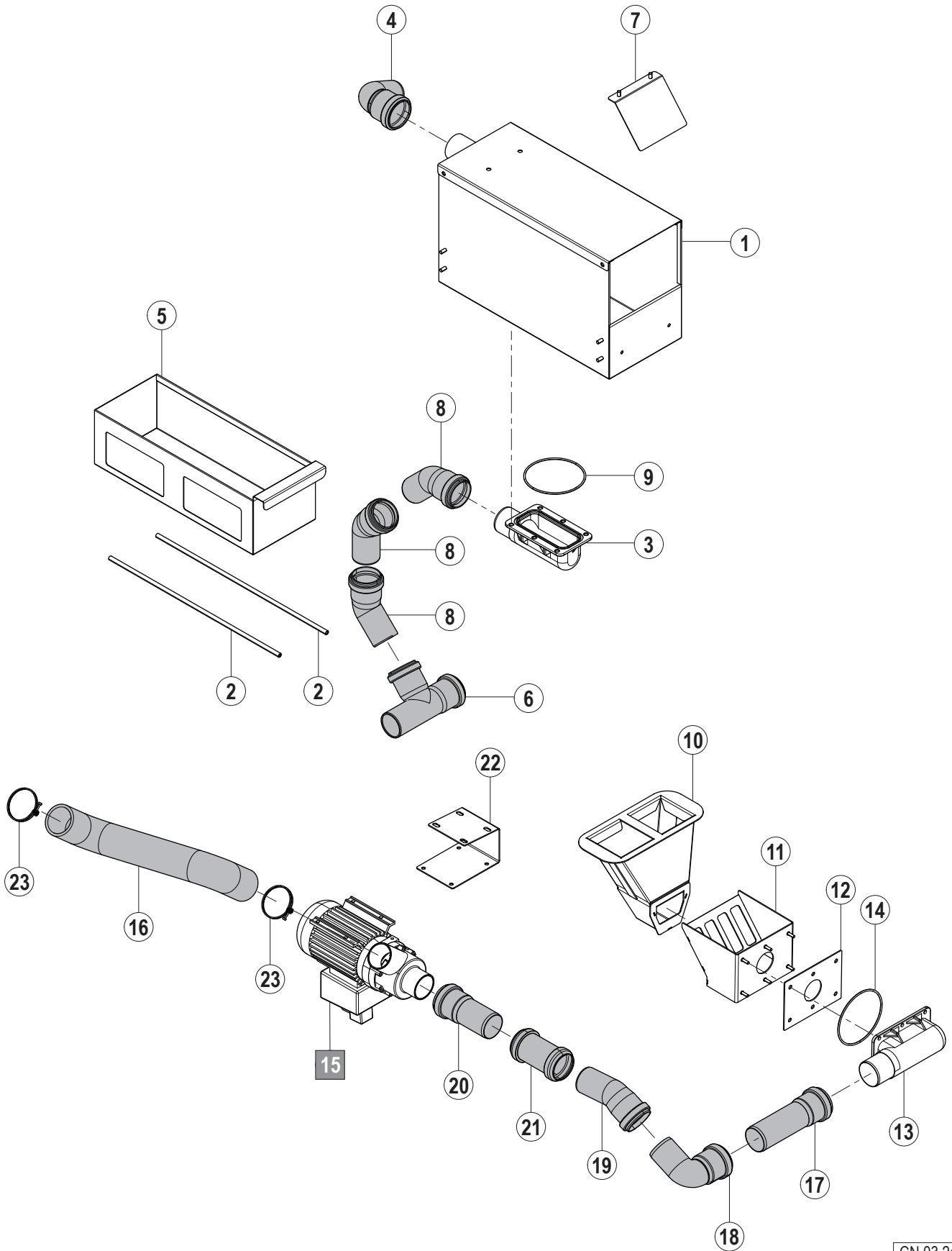

Pos.	A	B			X [mm]	Bemerkung / Remarks / Remarques
		CS	CN	CP		
01		---	01-296869-001	=		
02		---	01-245146-006	=		
03		---	00-325529-001	=		
04		---	00-230080-001	=		
05		---	01-296866-001	=		
06		---	00-230079-001	=		
07		---	01-518204-001	=		
08		---	00-377340-001	=		
09		---	00-276903-035	=		
10		---	01-297196-002	=		ohne Magnet / without magnet / sans aimant
		---	01-297196-005	=		mit Magnet / with magnet / avec aimant
11		---	01-297199-003	=		
12		---	01-297201-002	=		
13		---	00-325529-001	=		
14		---	00-276903-035	=		
15		---	01-297295-001	=		
16		---	01-296864-001	=		
17		---	00-229679-036	=		
18		---	00-230080-001	=		
19		---	00-377339-001	=		
20		---	00-229679-013	=		
21		---	00-229680-001	=		
22		---	01-296871-001	=		
23		---	00-323945-068	=		

CS / CN / CP
S/A Vorwaschung
S/A prewash
S/A prélavage

04.1

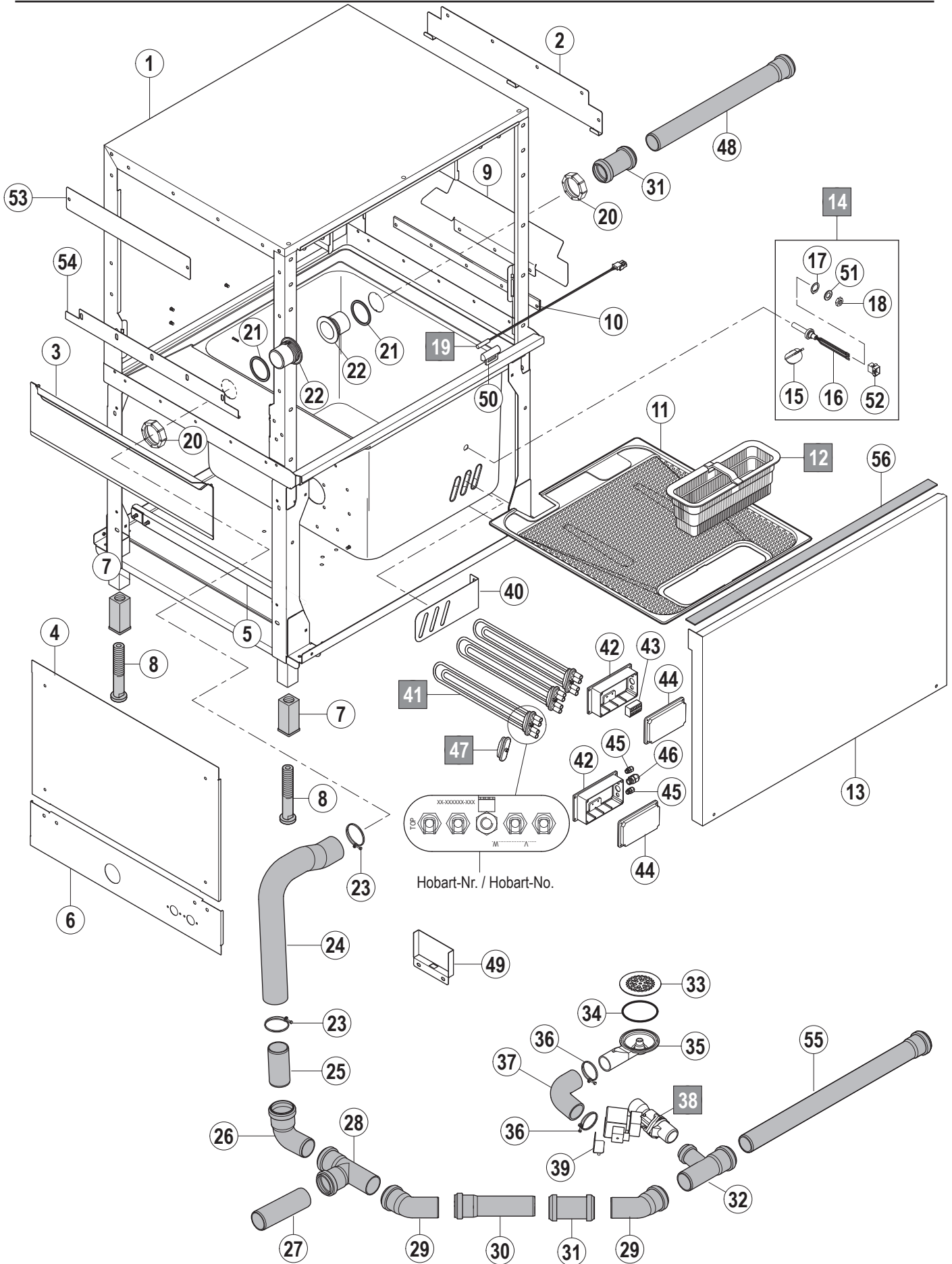

CN 04.1a

Pos.	A	B			X [mm]	Bemerkung / Remarks / Remarques
		CS	CN	CP		
01	L/R	---	01-291706-001	=		
	R/L	---	01-291706-002	=		
02		---	01-291538-001	=		
03		---	01-291429-001	=		
04		---	01-291409-001	=		ohne ASR / without ASR / sans ASR
		---	01-291409-007	=		mit ASR / with ASR / avec ASR
05		---	01-291432-001	=		
06	L/R	---	01-291408-001	=		
	R/L	---	01-291408-002	=		
07		---	00-325008-001	=		
08		---	00-325007-001	=		
09		---	00-896430-003	=		
10		---	00-325155-003	=		
11	L/R	---	01-245047-006	=		
	R/L	---	01-245047-005	=		
12		---	01-245170-010	=		Kunststoff / Plastic / Plastique
		---	01-245170-011	=		Kunststoff mit Magnet / plastic with magnet / plastique avec aimant
		---	01-245867-003	=		Edelstahl / Stainless steel / Acier inoxydable
		---	01-245867-007	=		Edelst. mit Magnet / stainl. steel with magnet / Acier inoxydable avec aimant
13	L/R	---	01-291407-004	=		nur / only / seulement S-Modul
	R/L	---	01-291407-005	=		nur / only / seulement S-Modul
		---	01-291407-011	=		nur / only / seulement A-Modul
14		---	01-245621-002	=		
15		---	00-122674-000	=		
16		---	01-296000-001	=		
17		---	00-112467-000	=		
18		---	00-602476-000	=		
19		---	01-240288-001	=		
20		---	01-245165-001	=		
21		---	01-245460-001	=		
22		---	01-245112-001	=		
23		---	00-323945-064	=		
24		---	01-291519-001	=		
25		---	00-325737-007	=		
26		---	00-230080-001	=		
27		---	00-325737-004	=		
28		---	00-230079-001	=		
29		---	00-377340-001	=		
30		---	00-600569-000	=		
31		---	00-229680-001	=		
32		---	00-323593-002	=		
33		---	01-245107-001	=		
34		---	01-245340-004	=		
35		---	01-245109-001	=		
36		---	00-325945-053	=		
37		---	01-291527-002	=		
38		---	00-774683-...	=		siehe Schaltplan / see wiring diagram / voir schéma de câblage
39		---	01-291684-002	=		
40		---	01-245372-002	=		

04.1

Pos.	A	B			X [mm]	Bemerkung / Remarks / Remarques
		CS	CN	CP		
41		---	00-324637-...	=		siehe Schaltplan / see wiring diagram / voir schéma de câblage
42		---	01-245373-001	=		
43		---	00-325025-000	=		
44		---	01-245374-001	=		
45		---	00-695661-001	=		
46		---	00-695661-003	=		
47		---	00-774808-001	=		
48		---	00-229679-025	=		
49		---	01-291982-001	=		
50		---	00-883838-001	=		
51		---	00-168611-021	=		
52		---	00-174994-013	---		
53		---	01-291197-004	---		
54		---	00-896394-001	=		nur S-Modul / only S-Module / seulement S-Module
55		---	00-229679-040	=		
56		---	01-296451-002	=		

04.2

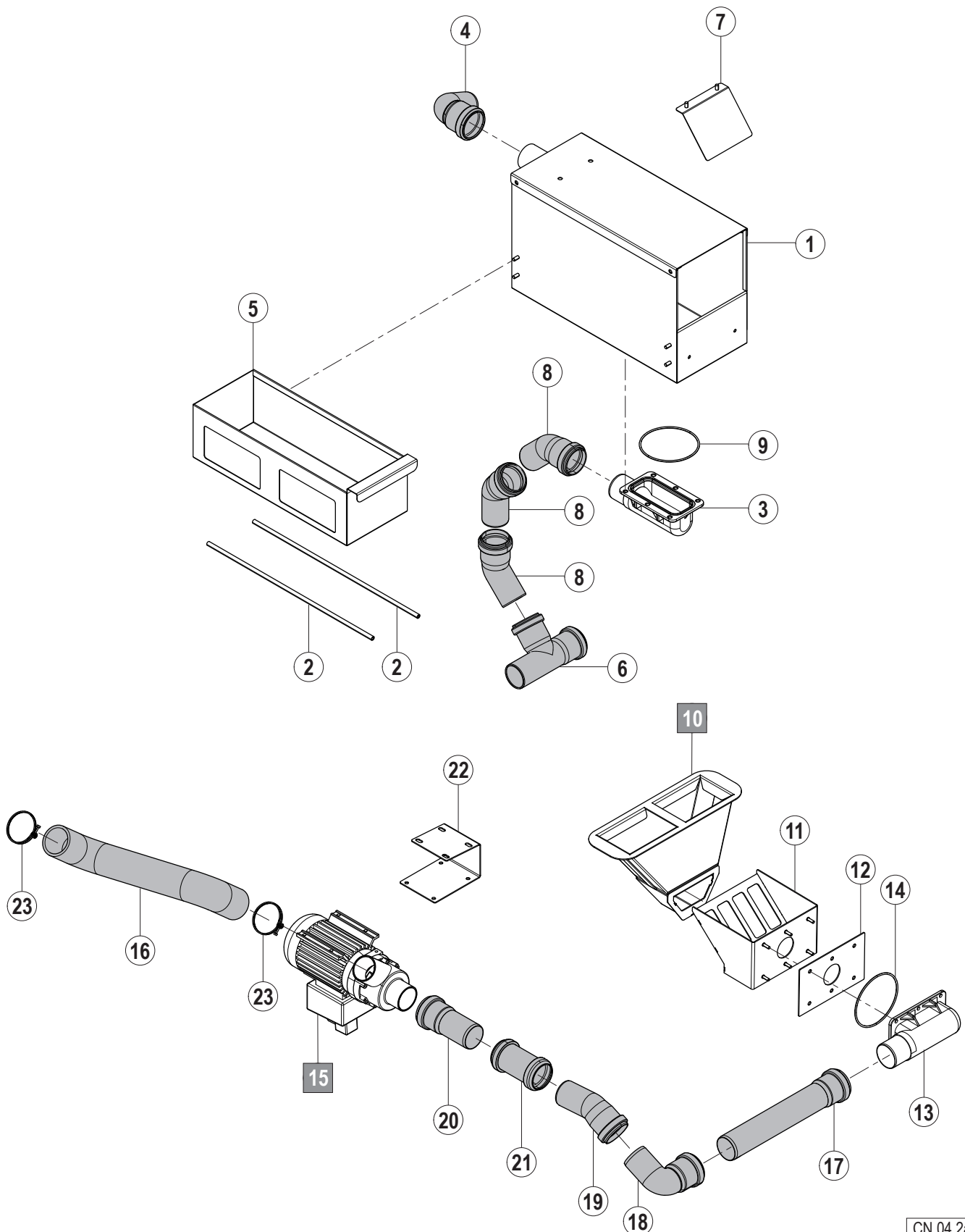

CN 04.2a

Pos.	A	B			X [mm]	Bemerkung / Remarks / Remarques
		CS	CN	CP		
01		---	01-296869-001	=		
02		---	01-245146-006	=		
03		---	00-325529-001	=		
04		---	00-230080-001	=		
05		---	01-296866-001	=		
06		---	00-230079-001	=		
07		---	01-518204-001	=		
08		---	00-377340-001	=		
09		---	00-276903-035	=		
10		---	01-297196-001	=		ohne Magnet / without magnet / sans aimant
		---	01-297196-004	=		mit Magnet / with magnet / avec aimant
11		---	01-297199-001	=		
12		---	01-297201-001	=		
13		---	00-325529-001	=		
14		---	00-276903-035	=		
15		---	01-297295-001	=		
16		---	01-296864-001	=		
17		---	00-229679-029	=		
18		---	00-230080-001	=		
19		---	00-377339-001	=		
20		---	00-229679-013	=		
21		---	00-229680-001	=		
22		---	01-296871-001	=		
23		---	00-323945-068	=		

CS / CN / CP

C Vorwaschung

C prewash

C prélavage

05.1

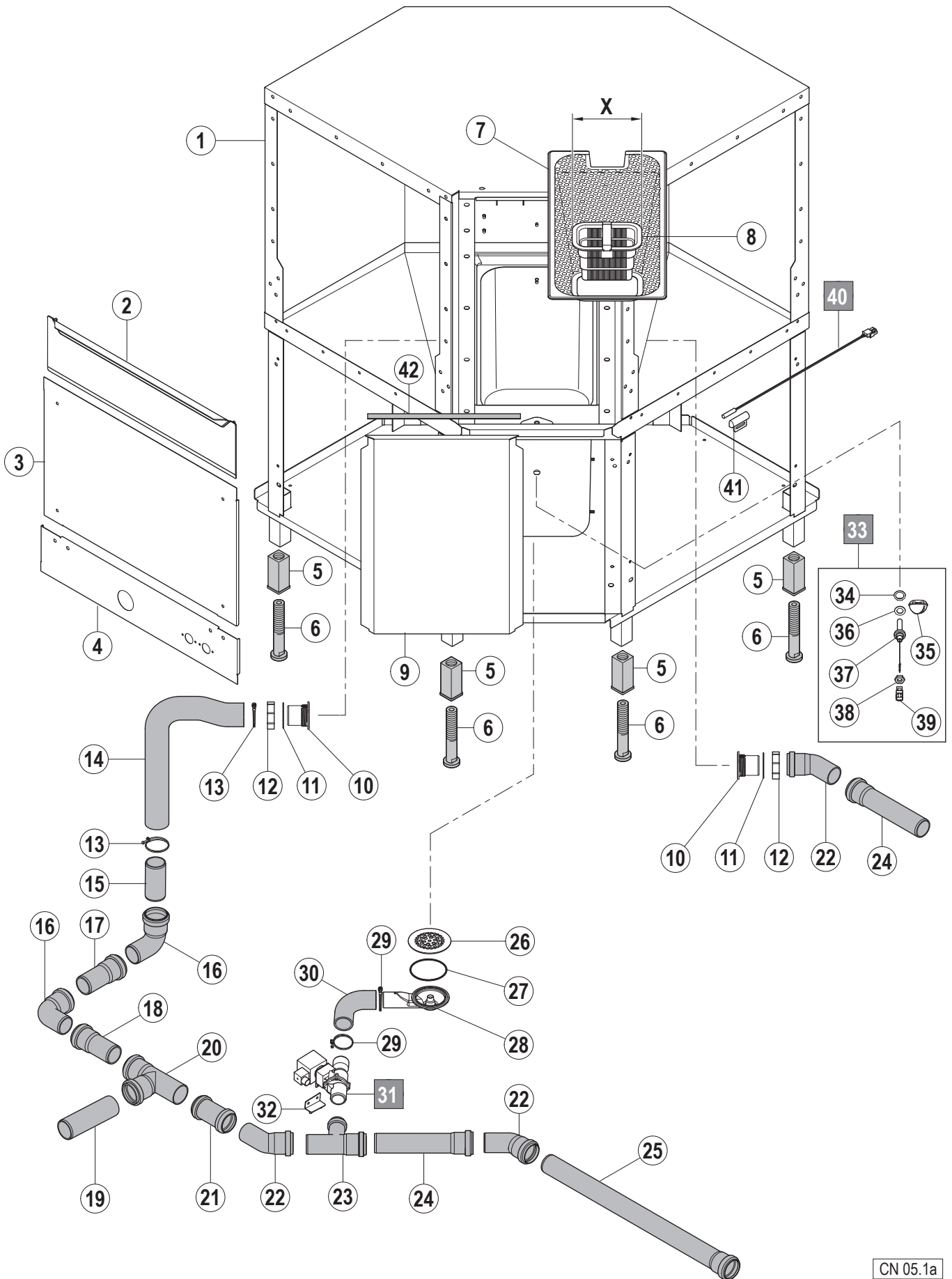

CN 05.1a

Pos.	A	B			X [mm]	Bemerkung / Remarks / Remarques
		CS	CN	CP		
01	L/R	---	01-291999-001	=		
	R/L	---	01-291999-002	=		
02		---	01-291429-001	=		
03		---	01-291409-001	=		ohne ASR / without ASR / sans ASR
	L/R	---	01-291409-006	=		mit ASR / with ASR / avec ASR
	R/L	---	01-291409-007	=		mit ASR / with ASR / avec ASR
04	L/R	---	01-291408-001	=		
	R/L	---	01-291408-002	=		
05		---	00-325008-001	=		
06		---	00-325007-001	=		
07		---	01-291289-001	=		Mit / With / Avec 01-291515-001 / 01-245867-004
		---	01-291298-002	=		Mit / With / Avec 01-291515-002 / 01-245867-005
08		---	01-291515-001	=	176	Kunststoff / Plastic / Plastique
		---	01-291515-002	=	246	Kunststoff / Plastic / Plastique
		---	01-291515-004	=	246	Kunststoff mit Magnet / plastic with magnet / plastique avec aimant
		---	01-245867-004	=	176	Edelstahl / Stainless steel / Acier inoxydable
		---	01-245867-008	=	246	Edelstahl / Stainless steel / Acier inoxydable
		---	01-245867-010	=	246	Edelst. mit Magnet / stainl. steel with magnet / Acier inoxydable avec aimant
09	L/R	---	01-296137-001	=		
	R/L	---	01-296137-002	=		
10		---	01-245112-001	=		
11		---	01-245460-001	=		
12		---	01-245265-001	=		
13		---	00-323945-064	=		
14		---	01-291519-001	=		
15		---	00-325737-001	=		
16		---	00-230080-001	=		
17		---	00-229679-013	=		
18		---	00-229679-012	=		
19		---	00-325737-004	=		
20		---	00-230079-001	=		
21		---	00-229680-001	=		
22		---	00-377340-001	=		
23		---	00-323593-002	=		
24		---	00-229679-024	=		
25		---	00-229679-005	=		
26		---	01-245107-001	=		
27		---	01-245340-004	=		
28		---	01-245109-001	=		
29		---	00-323945-053	=		
30		---	01-291527-002	=		
31		---	00-774683-...	=		siehe Schaltplan / see wiring diagram / voir schéma de câblage
32		---	01-291684-002	=		
33		---	01-245621-002	=		
34		---	00-112467-000	=		
35		---	00-112674-000	=		
36		---	00-168611-021	=		
37		---	01-296000-001	=		
38		---	00-602476-000	=		

Pos.	A	B			X [mm]	Bemerkung / Remarks / Remarques
		CS	CN	CP		
01		---	01-296139-001	=		
02		---	01-296055-001	=		
03		---	01-296049-001	=		
04		---	01-296059-001	=		
05		---	00-734988-001	=		
06		---	00-298963-012	=		
07		---	01-296138-001	=		
08		---	00-609067-000	=		
09		---	00-884128-003	=		
10		---	00-897777-002	=		
11		---	00-609313-000	=		
12		---	00-602643-000	=		
13		---	00-380528-037	=		
14	L/R	---	01-242189-001	=		
	R/L	---	01-242189-002	=		
15		---	00-774714-001	=		
16		---	01-291513-002	=		
17		---	01-240288-001	=		
18		---	01-240288-001	=		

05.3

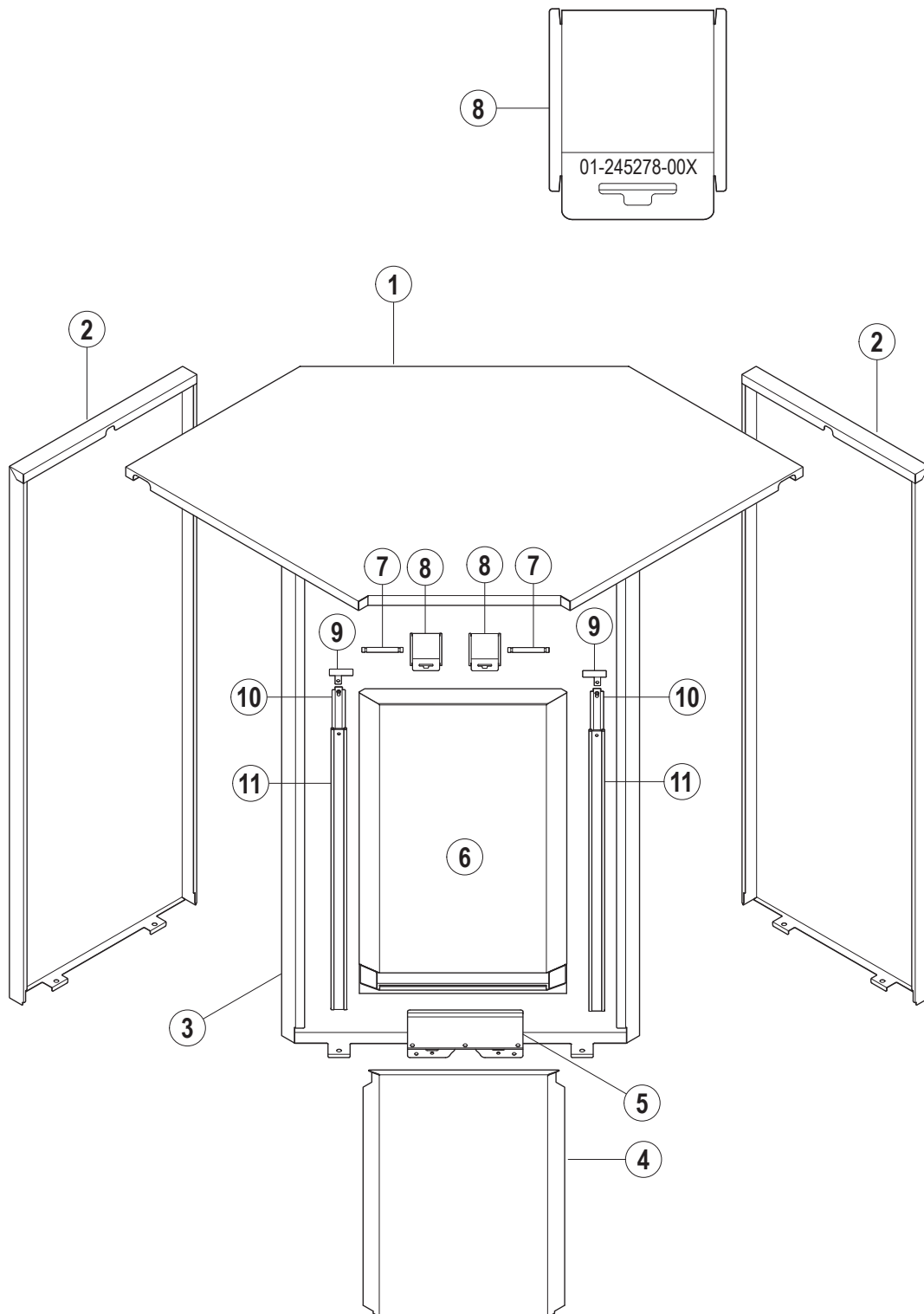

Pos.	A	B			X [mm]	Bemerkung / Remarks / Remarques
		CS	CN	CP		
01		---	01-296154-001	=		ohne Isolierung / without insulation / sans isolation
		---	01-296154-002	=		mit Isolierung / with insulation / avec isolation
02		---	01-291317-004	=		ohne Isolierung / without insulation / sans isolation
		---	01-291711-004	=		mit Isolierung / with insulation / avec isolation
03		---	01-296116-001	=		ohne Isolierung / without insulation / sans isolation
		---	01-291711-006	=		mit Isolierung / with insulation / avec isolation
04		---	01-296-137-001	=		
05		---	01-245279-003	=		
06		---	01-296112-001	=		
07		---	01-245281-001	=		
08		---	01-245278-008	=		
09		---	01-291426-001	=		
10		---	01-245126-003	=		
11		---	00-325064-008	=		

05.3

05.4

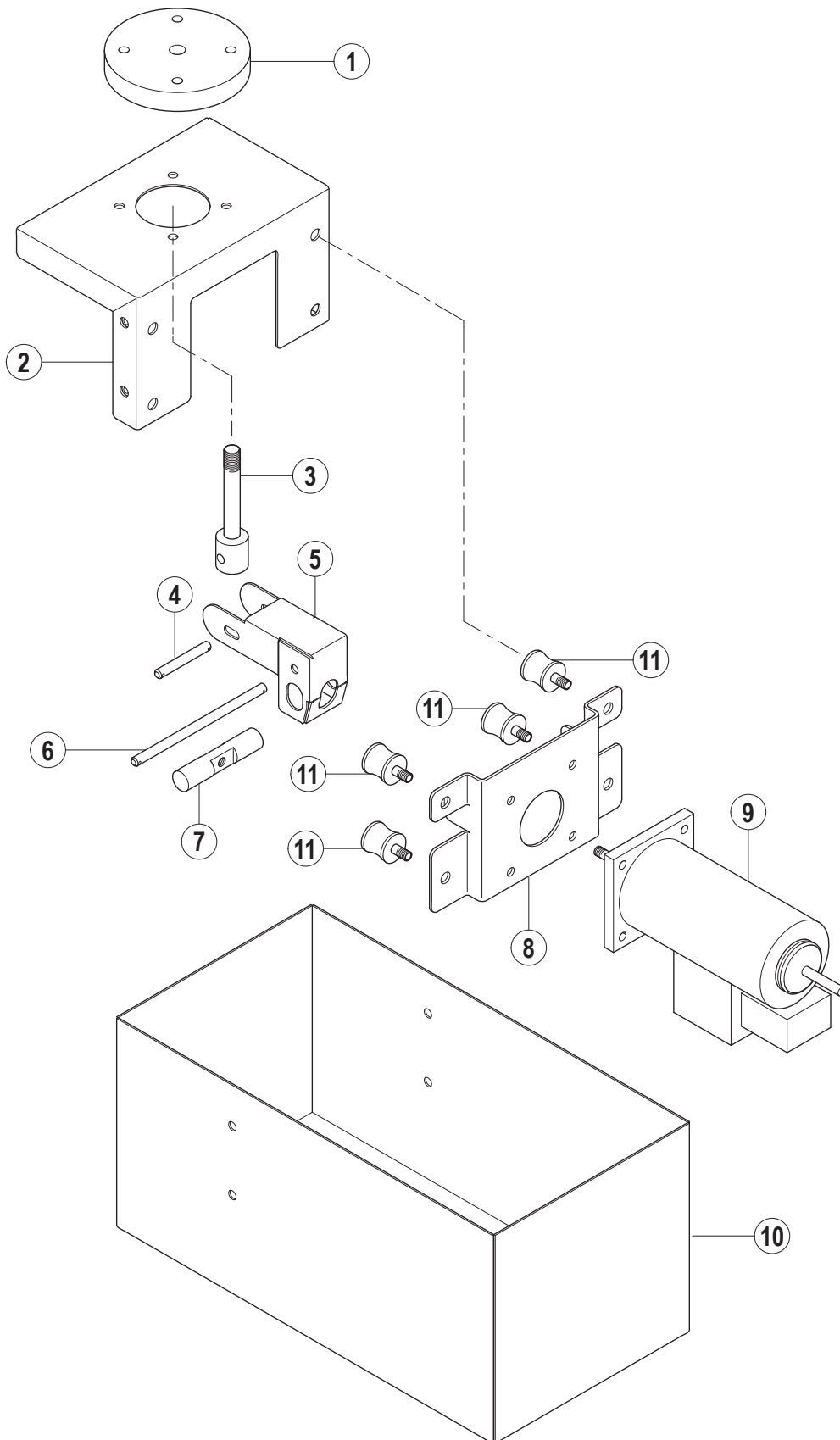

Pos.	A	B			X [mm]	Bemerkung / Remarks / Remarques
		CS	CN	CP		
01		---	00-887920-001	=		
02		---	00-887936-001	=		
03		---	00-887921-001	=		
04		---	00-380061-002	=		
05		---	00-868469-001	=		
06		---	00-380061-004	=		
07		---	00-693478-002	=		
08		---	00-868366-001	=		
09		---	00-696845-001	=		
10		---	00-897661-001	=		
11		---	00-696851-001	=		

05.4

CS / CN / CP
AR/AN Waschung
AR/AN wash
AR/AN lavage

06.1

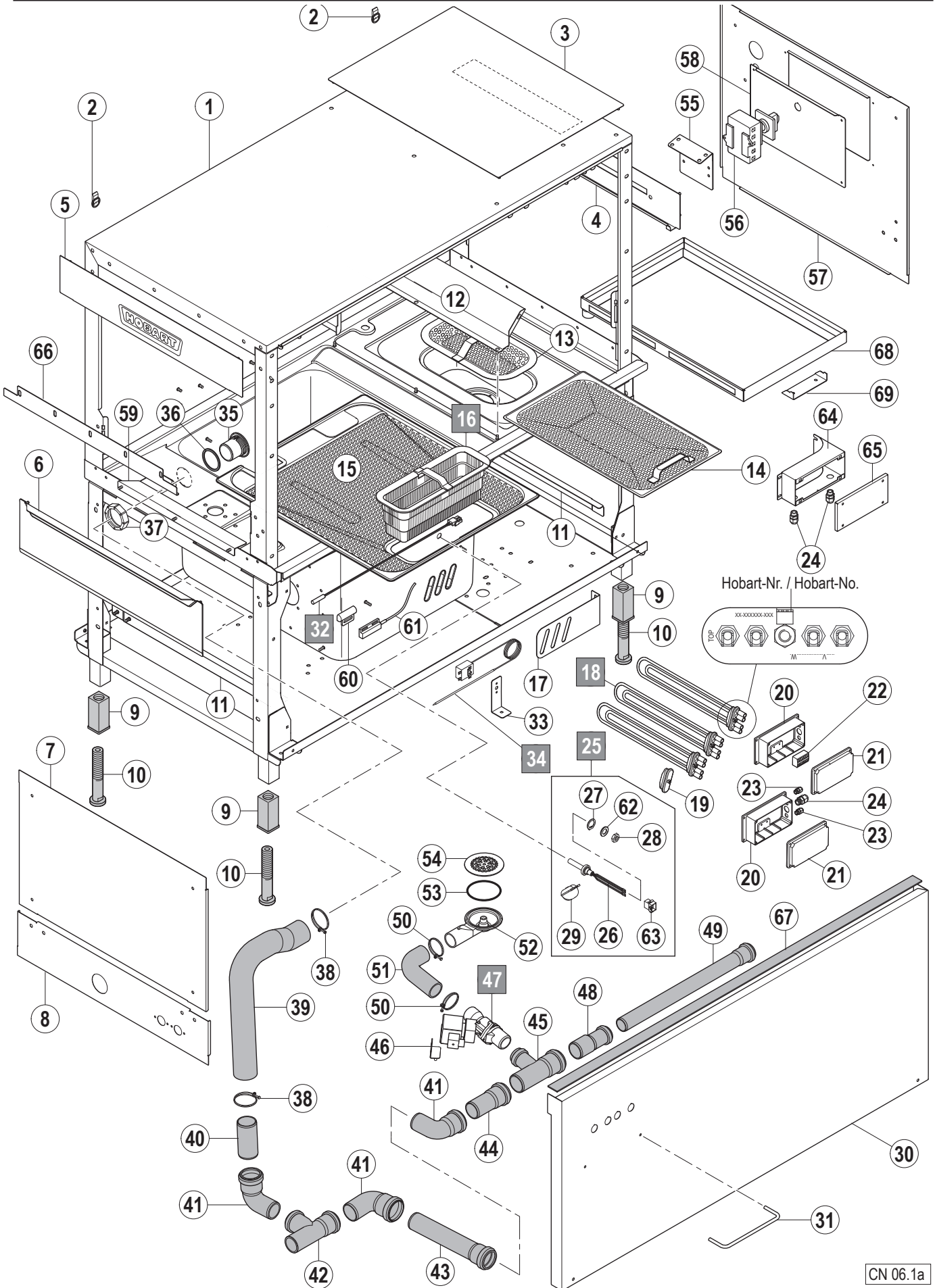

Pos.	A	B			X [mm]	Bemerkung / Remarks / Remarques
		CS	CN	CP		
01	L/R	01-245399-005	01-245399-001	01-245399-003		
	R/L	01-245399-006	01-245399-002	01-245399-004		
02		00-325037-001	---	---		
03		01-291799-001	---	---		
04		01-291434-001	=	=		
05		01-291497-001	---	---		
06		01-291429-001	=	=		
07		01-291409-001	=	=		
08	L/R	01-291408-001	=	=		
	R/L	01-291408-002	=	=		
09		00-325008-001	=	=		
10		00-325007-001	=	=		
11		01-291432-001	=	=		
12		01-245042-001	=	=		
13		00-325074-001	=	---		ohne Magnet / without magnet / sans aimant
		---	00-325074-002	---		mit Magnet / with magnet / avec aimant
14		---	---	01-245118-010		ohne Magnet / without magnet / sans aimant
		---	---	01-518207-003		mit Magnet / with magnet / avec aimant
15	L/R	01-245047-006	=	=		
	R/L	01-245047-005	=	=		
16		01-245170-010	=	=		Kunststoff / Plastic / Plastique
		---	01-245170-011	=		Kunststoff mit Magnet / plastic with magnet / plastique avec aimant
		01-245867-003	=	=		Edelstahl / Stainless steel / Acier inoxydable
		---	01-245867-007	=		Edelst. mit Magnet / stainl. steel with magnet / Acier inoxydable avec aimant
17		01-245372-002	=	=		
18		00-324637-...	=	=		siehe Schaltplan / see wiring diagram / voir schéma de câblage
19		00-774808-001	=	=		
20		---	01-245373-001	=		
21		---	01-245374-001	=		
22		---	00-325025-000	=		
23		---	00-695661-001	=		
24		---	00-695661-003	=		
25		01-245621-003	01-245621-002	=		
26		00-226282-012	01-296000-001	=		
27		00-112467-000	=	=		
28		00-602476-000	=	=		
29		00-122674-000	=	=		
30	L/R	01-291787-001	01-291787-005	01-291407-010		mit Vorwaschung / with prewash / avec pré lavage
	R/L	01-291787-002	01-291787-006	01-291407-010		mit Vorwaschung / with prewash / avec pré lavage
		---	01-291787-004	---		ohne Vorwaschung / without prewash / sans pré lavage
31		00-895734-001	---	---		
32		---	01-240288-001	=		
33		00-895758-001	---	---		
34		00-226505-...	---	---		
35		01-245112-001	=	=		
36		01-245460-001	=	=		
37		01-245165-001	=	=		
38		00-323945-064	=	=		
39		01-291519-001	=	=		

Pos.	A	B			X [mm]	Bemerkung / Remarks / Remarques
		CS	CN	CP		
40		00-325737-007	=	=		
41		00-230080-001	=	=		
42		00-230079-001	=	=		
43		00-229679-006	=	=		
44		00-229679-013	=	=		
45		00-323593-002	=	=		
46		01-291684-001	=	=		
47		00-774683-...	=	=		siehe Schaltplan / see wiring diagram / voir schéma de câblage
48		00-325708-001	=	=		
49		00-325706-017	=	=		
50		00-323945-053	=	=		
51		01-291527-001	=	=		
52		01-245109-001	=	=		
53		01-245340-004	=	=		
54		01-245107-001	=	=		
55		01-291425-001	=	---		
56		00-785574-...	=	---		siehe Schaltplan / see wiring diagram / voir schéma de câblage
57	L/R	01-296274-001	=	---		
	R/L	01-296274-002	=	---		
58		01-291427-001	=	---		
59		00-895737-001	---	---		
60		---	00-883838-001	---		
61		00-229517-000	---	---		
62		---	00-168611-021	=		
63		---	00-174994-013	---		
64	L/R	---	---	01-245657-001		
	R/L	---	---	01-245657-002		
65		---	---	01-296584-002		
66		00-896394-001	=	=		
67		01-296451-001	=	=		
68		---	---	01-292020-005		mit SENSOTRONIC / with SENSOTRONIC / avec SENSOTRONIC
69		---	---	01-245968-003		mit SENSOTRONIC / with SENSOTRONIC / avec SENSOTRONIC

06.2

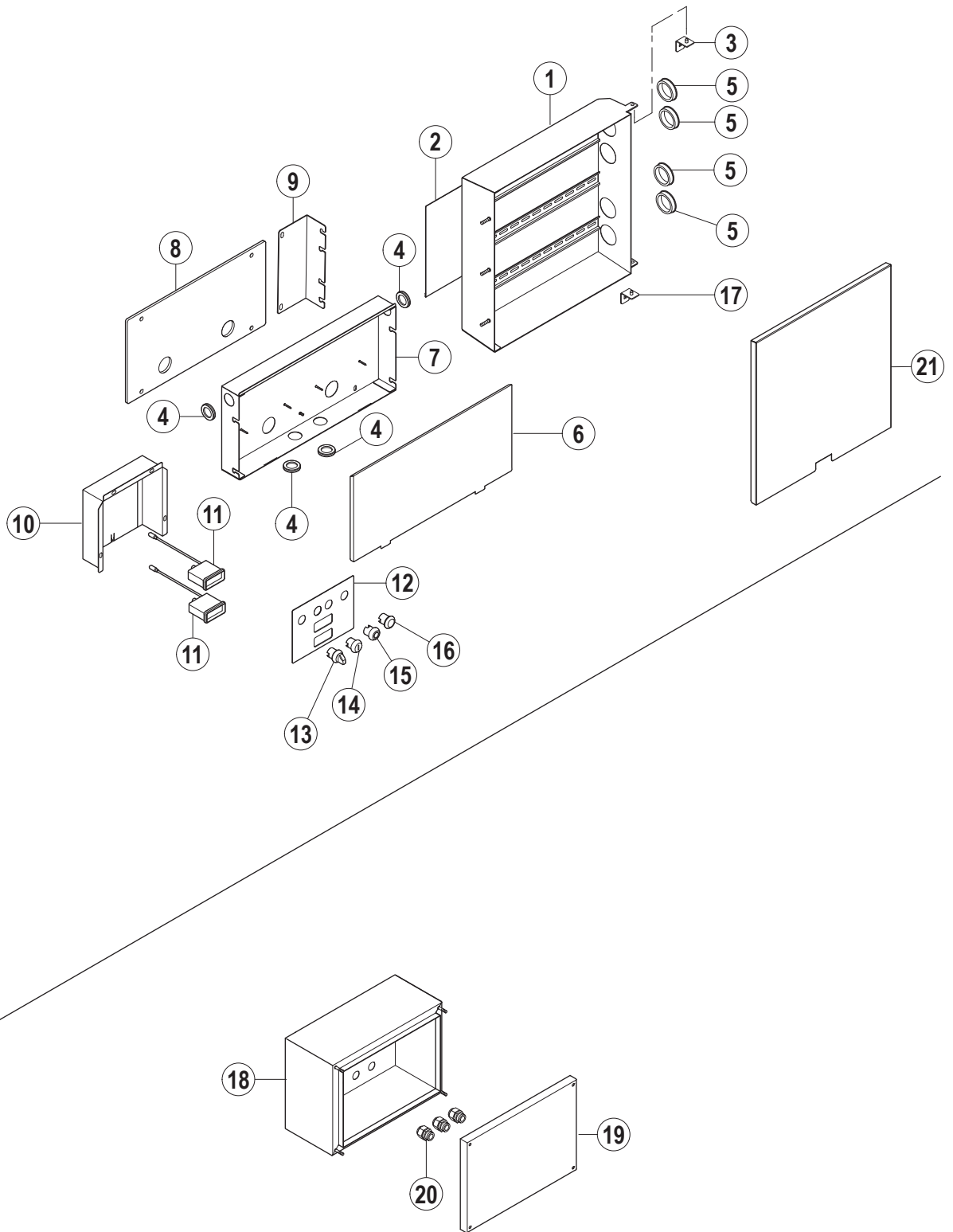

CN 06.2a

Pos.	A	B			X [mm]	Bemerkung / Remarks / Remarques
		CS	CN	CP		
01	L/R	01-518293-001	=	---		
	R/L	01-518293-002	=	---		
02		00-374384-000	=	---		
03		01-245228-002	=	---		
04		00-785565-005	=	---		
05		00-886756-001	=	---		
06		00-895732-001	=	---		
07		01-291424-001	=	---		
08		01-291499-001	=	---		
09		01-291786-001	---	---		
10		00-899256-001	---	---		
11		00-228720-003	---	---		
12		01-291809-001	---	---		ohne / without / sans Pos.11
		01-291809-002	---	---		mit / with / avec Pos.11
13		00-8870015-61	---	---		
14		00-887015-033	---	---		
15		00-887015-021	---	---		
16		00-887015-047	---	---		
17		01-245228-003	=	---		
18		=	01-296478-001	=		
19		=	01-296485-001	=		
20		=	00-695661-003	=		
21		01-296475-001	=	---		

CS / CN / CP

ND Modul

ND Module

ND Module

07.1

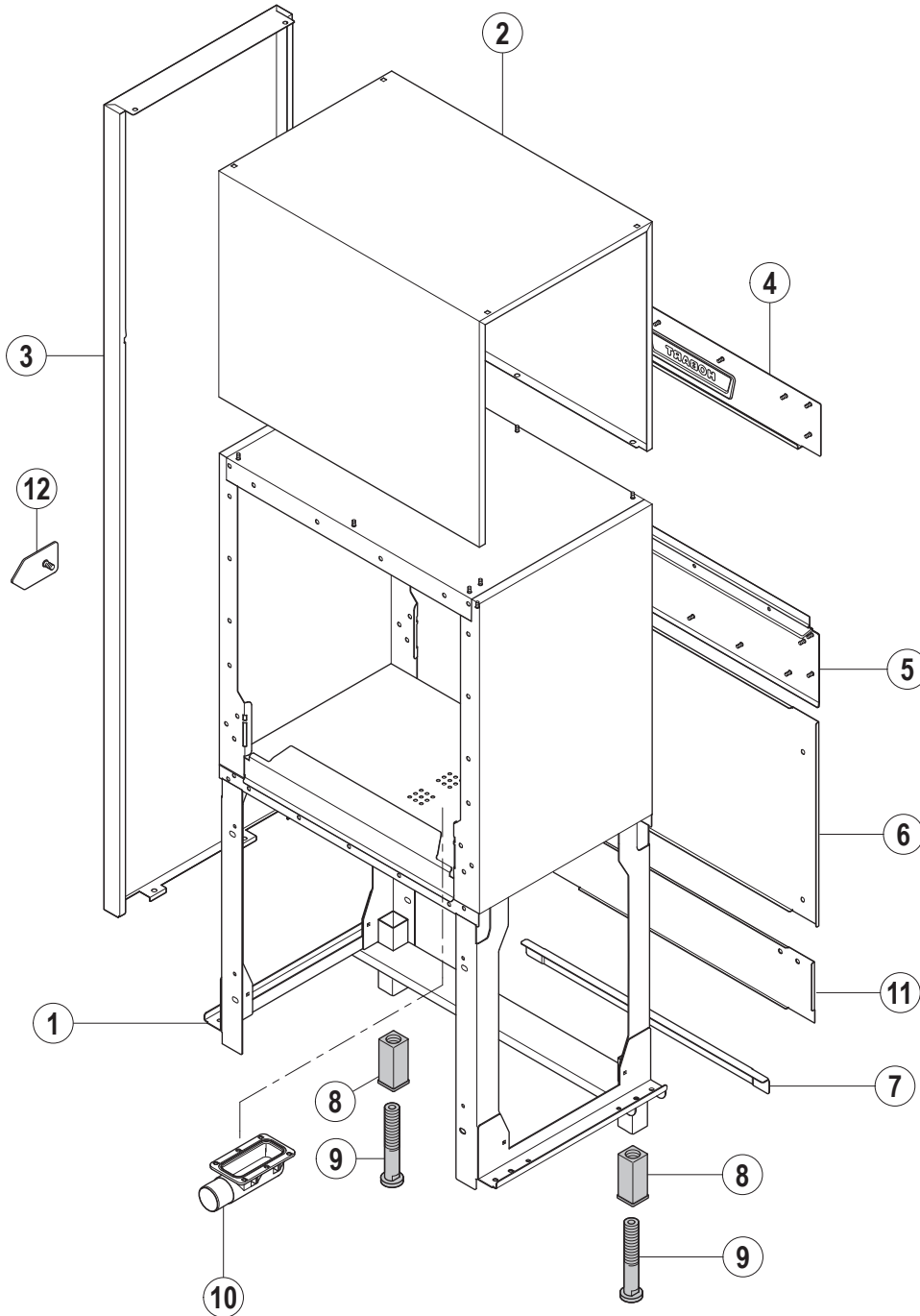

CN 07.1a

Pos.	A	B			X [mm]	Bemerkung / Remarks / Remarques
		CS	CN	CP		
01		---	01-291518-002	=		
02		---	01-291673-001	=		
03		---	01-291466-003	=		
04		---	01-291497-001	=		
05		---	01-291429-002	=		
06		---	01-291419-014	=		
07		---	01-291432-001	=		
08		---	00-325008-001	=		
09		---	00-325007-001	=		
10		---	00-325529-001	=		
11		---	01-296552-001	=		
12		---	01-296621-001	=		

07.2

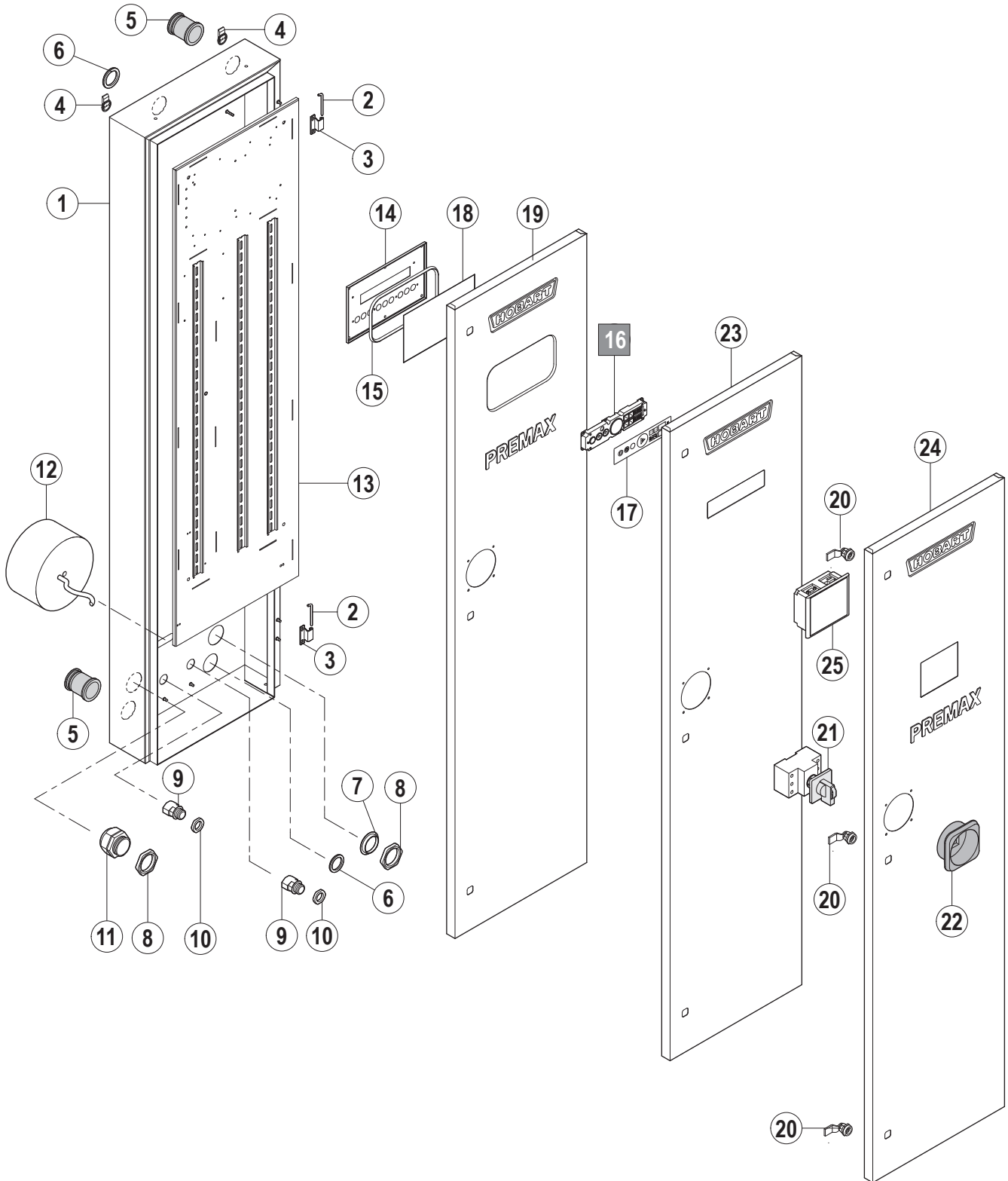

Pos.	A	B			X [mm]	Bemerkung / Remarks / Remarques
		CS	CN	CP		
01		---	01-291469-002	=		
02		---	00-325086-013	=		
03		---	00-325086-011	=		
04		---	00-325037-001	=		
05		---	00-325186-001	=		
06		---	00-325655-001	=		
07		---	00-695666-007	=		
08		---	00-695664-007	=		
09		---	00-774797-002	=		
10		---	00-695664-004	=		
11		---	00-695661-007	=		
12		---	00-774783-...	=		siehe Schaltplan / see wiring diagram / voir schéma de câblage
13		---	00-868499-003	=		
14		---	01-245672-001	=		
15		---	00-325554-004	=		
16		---	00-897540-002	---		
17		---	01-291845-001	---		
18		---	01-245674-002	=		
19		---	01-291472-001	01-291472-002		
20		---	00-229518-001	=		
21		---	00-301773-...	=		siehe Schaltplan / see wiring diagram / voir schéma de câblage
22		---	00-734115-002	00-734115-003		
23		---	01-291472-003	---		
24		---	01-291472-005	01-291472-004		
25		---	00-887104-002	00-887104-001		

07.2

CS / CN / CP

Spülmodul

Rinse module

Module de rinçage

08.1

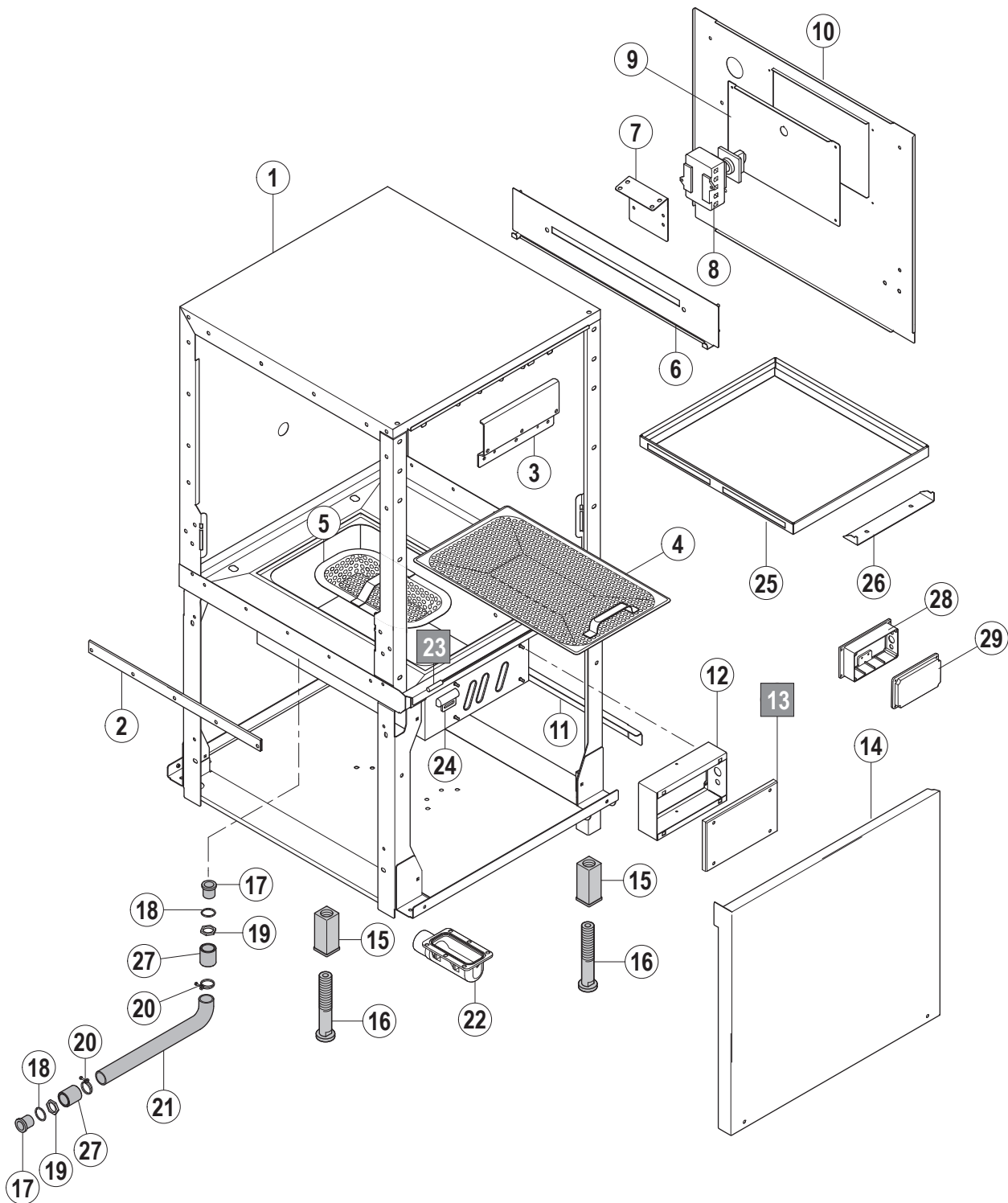

CN 08.1

Pos.	A	B			X [mm]	Bemerkung / Remarks / Remarques
		CS	CN	CP		
01	L/R	---	01-291880-001	01-291880-003		
	R/L		01-291880-002	01-291880-004		
02		---	00-325155-003	=		
03		---	01-245279-002	=		
04		---	---	01-245118-010		ohne Magnet / without magnet / sans aimant
		---	---	01-518207-003		mit Magnet / with magnet / avec aimant
05		---	00-868460-001	---		ohne Magnet / without magnet / sans aimant
		---	00-868460-002	---		mit Magnet / with magnet / avec aimant
06		---	01-291434-001	=		
07		---	01-291425-002	---		
08		---	00-785574-...	---		siehe Schaltplan / see wiring diagram / voir schéma de câblage
09		---	01-291427-001	---		
10	L/R	---	01-291419-001	---		
	R/L		01-291419-002	---		
11		---	01-291432-011	=		
12		---	---	01-245655-002		
13		---	---	01-245656-004		
14	L/R	---	01-291407-007	01-291407-008		
	R/L		01-291407-006	01-291407-008		
15		---	00-325008-001	=		
16		---	00-325007-001	=		
17		---	00-229446-003	=		
18		---	00-168611-011	=		
19		---	00-172739-002	=		
20		---	00-323945-033	=		
21		---	00-898242-003	=		
22		---	00-325529-001	=		
23		---	01-240288-001	=		
24		---	00-883838-001	=		
25		---	---	01-292020-006		mit SENSOTRONIC / with SENSOTRONIC / avec SENSOTRONIC
26		---	---	01-245968-001		mit SENSOTRONIC / with SENSOTRONIC / avec SENSOTRONIC
27		---	00-226973-006	=		
28		---	01-245373-001	=		
29		---	01-245374-001	=		

08.2

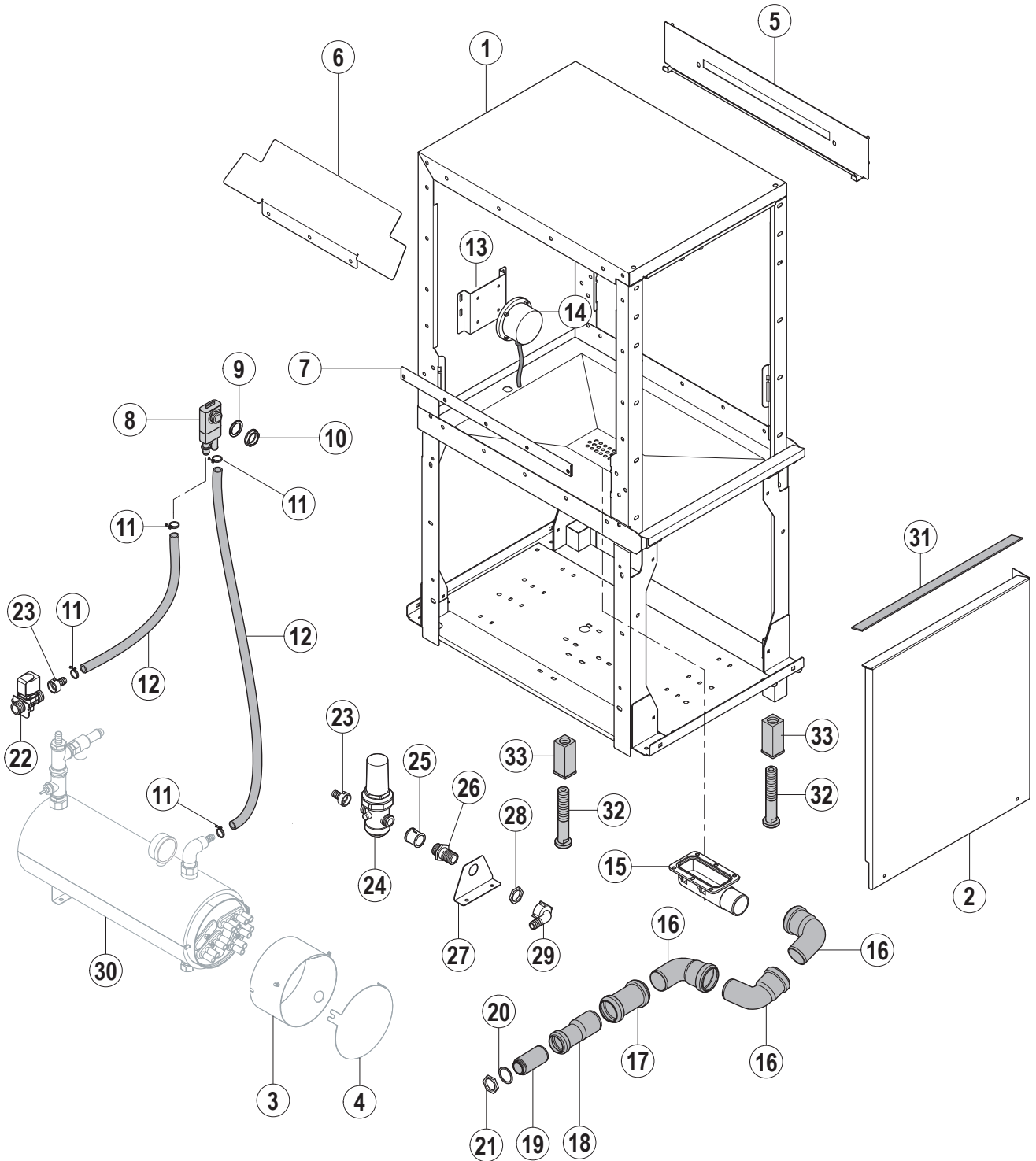

Pos.	A	B			X [mm]	Bemerkung / Remarks / Remarques
		CS	CN	CP		
01	L/R	---	01-296356-001	---		
	R/L	---	01-296356-002	---		
02	L/R	---	01-291407-009	---		
	R/L	---	01-291407-015	---		
		---	01-291407-016	---		
03		---	01-249044-001	---		
04		---	01-296351-001	---		
05		---	01-291434-001	---		
06		---	00-896430-003	---		
07		---	00-325155-003	---		
08		---	00-775759-001	---		
09		---	00-775305-001	---		
10		---	00-324384-000	---		
11		---	00-323945-022	---		
12		---	01-245571-001	---		
13		---	00-868978-002	---		
14		---	00-301745-001	---		
15		---	00-325529-001	---		
16		---	00-230080-001	---		
17		---	00-229680-001	---		
18		---	00-325708-001	---		
19		---	00-774616-001	---		
20		---	00-172986-028	---		
21		---	00-172739-008	---		
22		---	00-297808-010	---		
23		---	00-302201-001	---		
24		---	00-229110-002	---		
25		---	00-603051-000	---		
26		---	01-245850-001	---		
27		---	01-296341-001	---		
28		---	00-172739-002	---		
29		---	00-299240-001	---		
30		---	01-291554-...	---		Details siehe 11.1 / details see 11.1 / détails regardez 11.1
31		---	01-296451-003	---		
32		---	00-325007-001	---		
33		---	00-325008-001	---		

CS / CN / CP

Trennmodul

Disconnecting module

Module de passage

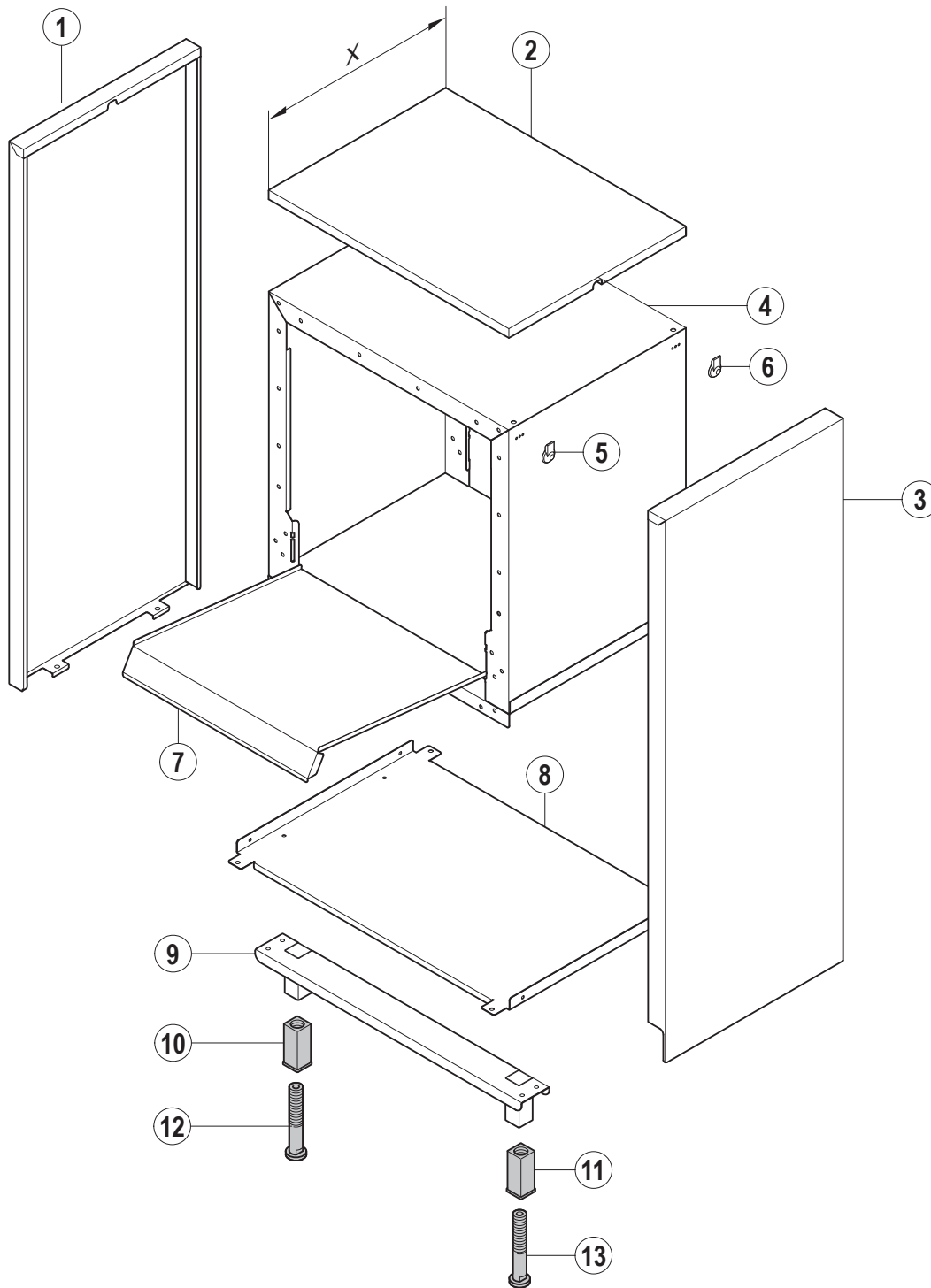

09.1

Pos.	A	B			X [mm]	Bemerkung / Remarks / Remarques
		CS	CN	CP		
01		---	01-291317-004	=	500	
		---	01-291317-008	=	300	
02		---	01-291397-004	=	500	
		---	01-291397-007	=	300	
03		---	01-291866-001	=	500	
		---	01-291866-002	=	300	
04		---	01-291860-001	=	500	
		---	01-291860-002	=	300	
05		---	00-325037-001	=		
06		---	01-291857-001	=	500	
		---	01-291857-002	=	300	
07		---	01-291856-001	=	500	
		---	01-291856-002	=	300	
08		---	01-291366-005	=		
09		---	00-325008-001	=		
10		---	00-325007-001	=		

CS / CN / CP
Waschsystem
Wash system
Système de lavage

10.1

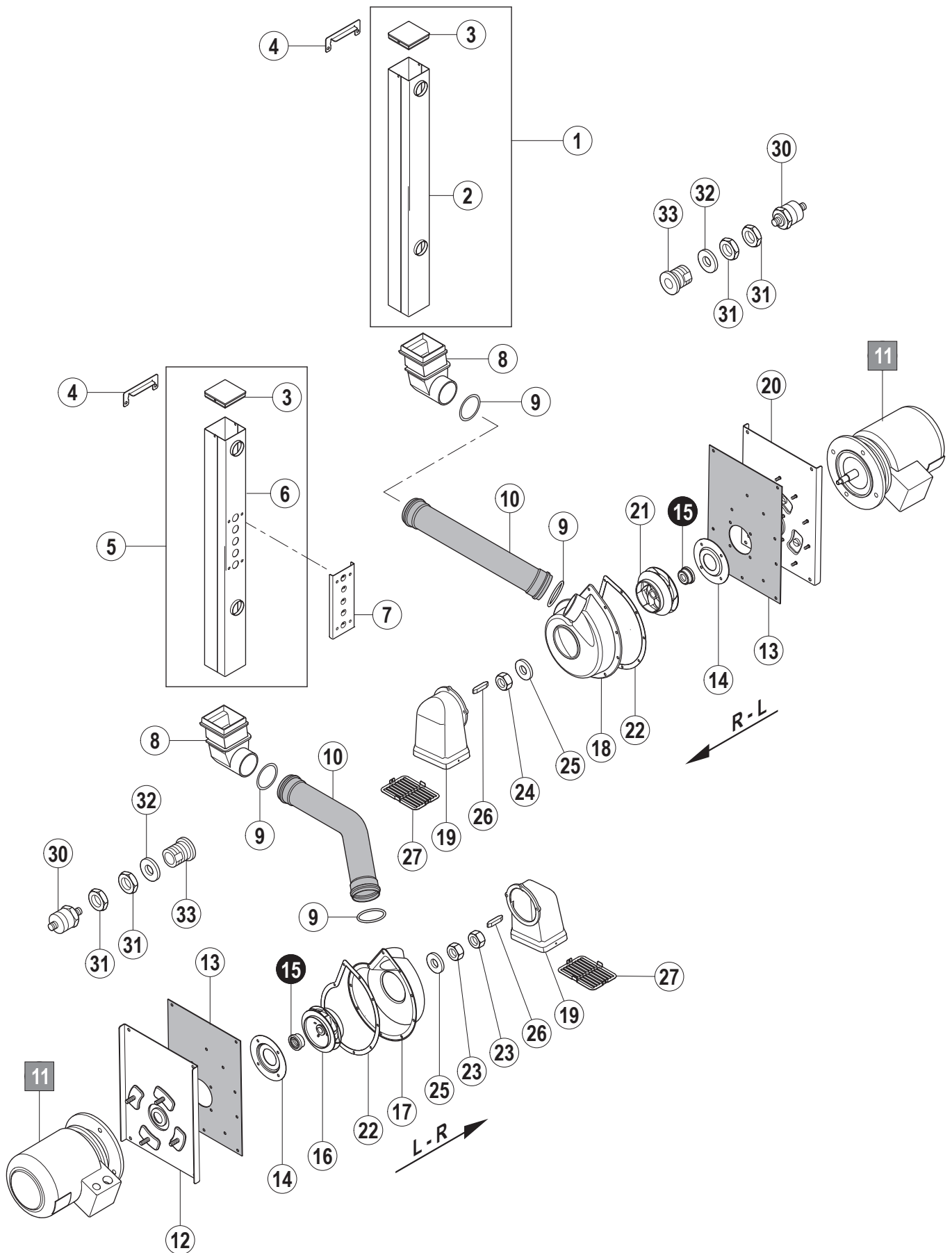

Pos.	A	B			X [mm]	Bemerkung / Remarks / Remarques
		CS	CN	CP		
01		01-245669-005	=	=		
02		01-245110-005	=	=		
03		01-245086-002	=	=		
04		01-245979-001	=	=		
05		---	01-245669-008	=		
06		---	01-245110-008	=		
07		---	01-245428-002	=		
08		01-245055-001	=	=		
09		01-245340-003	=	=		
10		01-245277-001	=	=		
11		01-245176-...	=	=		siehe Schaltplan / see wiring diagram / voir schéma de câblage
12	L/R	01-245835-003	=	=		
13		01-245386-002	=	=		
14		01-245379-001	=	=		
15		01-245033-002	=	=		
16	L/R	01-245162-004	---	---		AR-Modul (50/60 Hz)
	L/R	---	01-245162-003	01-245162-003		S-Modul (50 Hz); AR-Modul (50 Hz)
	L/R	---	01-245162-004	01-245162-004		S-Modul (60 Hz); AR-Modul (60 Hz)
	L/R	---	01-245162-004	01-245162-004		L-Modul (50/60 Hz)
17	L/R	01-245135-004	=	=		
18	R/L	01-245135-005	=	=		
19		01-245713-001	=	=		
20	R/L	01-245835-004	=	=		
21	R/L	01-245088-004	---	---		AR-Modul (50/60 Hz)
	R/L	---	01-245088-003	01-245088-003		S-Modul (50 Hz); AR-Modul (50 Hz)
	R/L	---	01-245088-004	01-245088-004		S-Modul (60 Hz); AR-Modul (60 Hz)
	R/L	---	01-245088-004	01-245088-004		L-Modul (50/60 Hz)
22		01-245459-001	=	=		
23	L/R	00-603465-000	=	=		
24	R/L	00-602504-000	=	=		
25		00-602288-000	=	=		
26		00-609801-000	=	=		
27		01-245377-002	=	=		
30	t	---	---	01-297200-001		
31		---	---	00-172739-001		
32		---	---	00-172986-003		
33		---	---	00-869222-002		

10.2

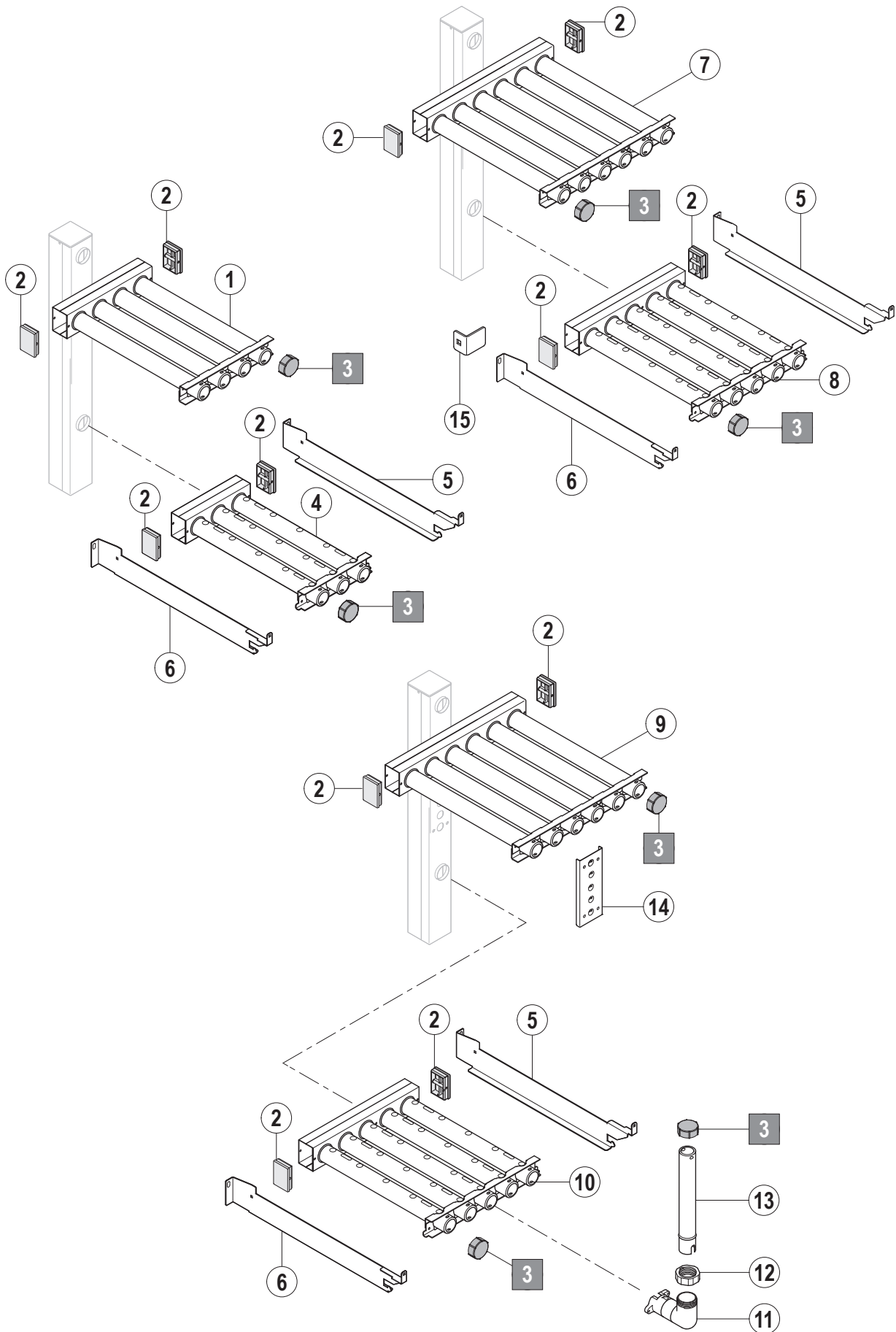

Pos.	A	B			X [mm]	Bemerkung / Remarks / Remarques
		CS	CN	CP		
01	L/R	01-291302-009	---	---		AR-Modul
	R/L	01-291302-011	---	---		AR-Modul
	L/R	---	01-291302-005	=		L-Modul
	R/L	---	01-291302-007	=		L-Modul
	L/R	---	01-291302-017	=		C-Modul
	R/L	---	01-291302-019	=		C-Modul
02		01-245086-001	=	=		
03		01-245084-002	=	=		
04	L/R	01-291302-010	---	---		AR-Modul
	R/L	01-291302-012	---	---		AR-Modul
	L/R	---	01-291302-006	=		L-Modul
	R/L	---	01-291302-008	=		L-Modul
	L/R	---	01-291302-018	=		C-Modul
	R/L	---	01-291302-020	=		C-Modul
05		01-291358-001	=	=		
06		01-291358-002	=	=		
07	L/R	---	01-291302-001	=		AR-Modul, S-Modul
	R/L	---	01-291302-003	=		AR-Modul, S-Modul
08	L/R	---	01-291302-002	=		AR-Modul, S-Modul
	R/L	---	01-291302-004	=		AR-Modul, S-Modul
09	L/R	---	01-291302-015	=		AR-Modul
	R/L	---	01-291302-016	=		AR-Modul
10	L/R	---	01-291302-013	=		AR-Modul
	R/L	---	01-291302-014	=		AR-Modul
11		---	01-296040-001	=		
12		---	01-245424-001	=		
13	L/R	---	01-291869-001	=		
	R/L	---	01-291869-002	=		
14		---	01-245428-002	=		
15		---	01-291886-001	=		

10.2

CS / CN / CP

Erhitzer

Booster

Chaudière

11.1

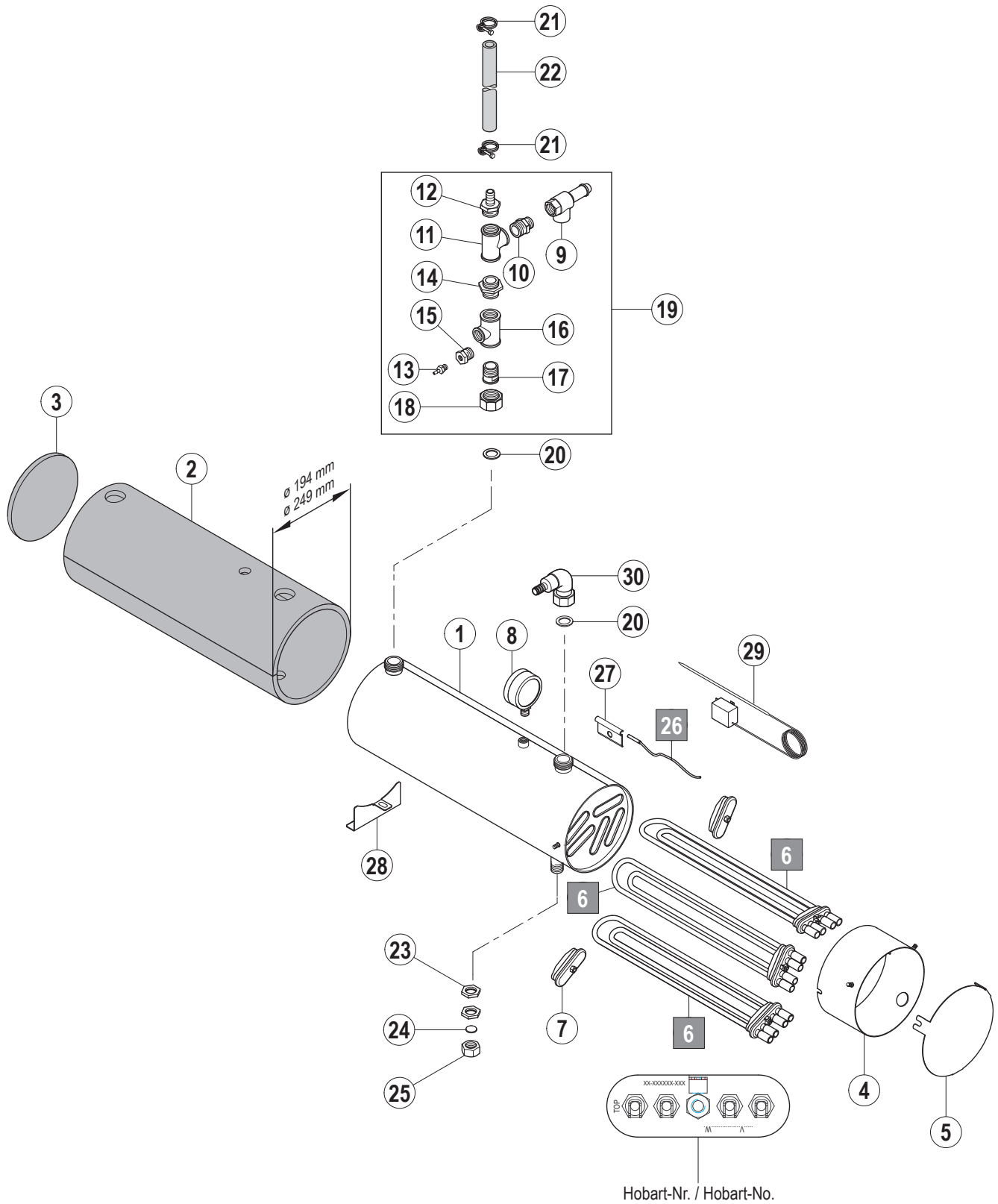

Pos.	A	B			X [mm]	Bemerkung / Remarks / Remarques
		CS	CN	CP		
01		00-897683-001	=	=	Ø194	mit Isolierung / with insulation / avec isolation
		01-241873-001	=	=	Ø249	mit Isolierung / with insulation / avec isolation
02		00-897657-001	=	=	Ø194	
		01-241874-001	=	=	Ø249	
03		00-897657-002	=	=	Ø194	
		01-241876-001	=	=	Ø249	
04		01-249044-001	=	=	Ø194	
		01-249044-002	=	=	Ø249	
05		01-296351-001	=	=	Ø194	
		01-296351-002	=	=	Ø249	
06		00-324637-...	=	=		Nr. siehe Flansch / no. see flange / no. voir bride
07		00-774808-001	=	=		
08		00-229583-001	=	=		
09		00-229621-000	=	=		
10		00-602757-000	=	=		
11		00-603163-000	=	=		
12		00-897680-001	=	=		
13		00-227249-003	=	=		
14		00-227931-000	=	=		
15		01-291287-001	=	=		
16		01-291288-001	=	=		
17		01-291286-001	=	=		
18		00-600806-000	=	=		
19		01-244435-002	=	=		
20		00-168611-003	=	=		
21		00-323945-022	=	=		
22		01-245571-002	=	=		L=2000 mm
23		00-172739-001	=	=		
24		00-168611-022	=	=		
25		00-600588-000	=	=		
26		---	00-775612-001	=		
27		00-775489-001	=	=		
28		01-243201-001	=	=		
29		00-226-505-004	---	---		
30		01-296696-001	=	=		

11.2

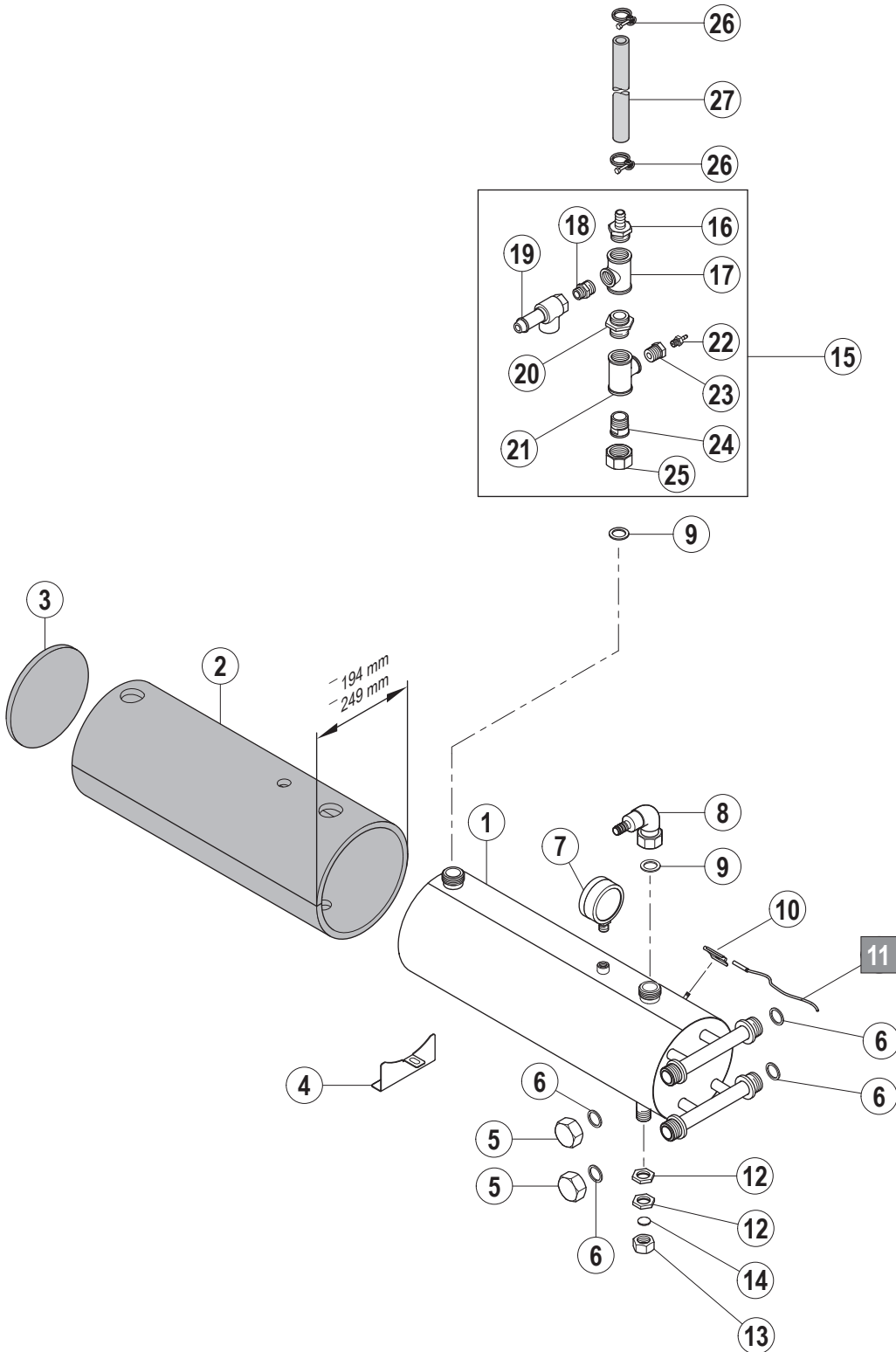

CN 11.2

Pos.	A	B			X [mm]	Bemerkung / Remarks / Remarques
		CS	CN	CP		
01		---	01-245602-002	=	Ø194	mit Isolierung / with insulation / avec isolation
		---	01-245951-002	=	Ø249	mit Isolierung / with insulation / avec isolation
02		---	00-897657-001	=	Ø194	
		---	01-241874-001	=	Ø249	
03		---	00-897657-002	=	Ø194	
		---	01-241876-001	=	Ø249	
04		---	01-243201-001	=		
05		---	01-245605-001	=		
06		---	00-302574-014	=		
07		---	00-229583-001	=		
08		---	01-296696-001	=		
09		---	00-168611-003	=		
10		---	00-775489-001	=		
11		---	00-775612-001	=		
12		---	00-172739-001	=		
13		---	00-600588-000	=		
14		---	00-168611-022	=		
15		---	01-244435-002	=		
16		---	00-897680-001	=		
17		---	00-603163-000	=		
18		---	00-602757-000	=		
19		---	00-229621-000	=		
20		---	00-227931-000	=		
21		---	01-291288-001	=		
22		---	00-227249-003	=		
23		---	01-291287-001	=		
24		---	01-291286-001	=		
25		---	00-600806-000	=		
26		---	00-323945-022	=		
27		---	01-245571-002	=		L=2000 mm

CS / CN / CP

Spülsystem

Rinse system

Système de rinçage

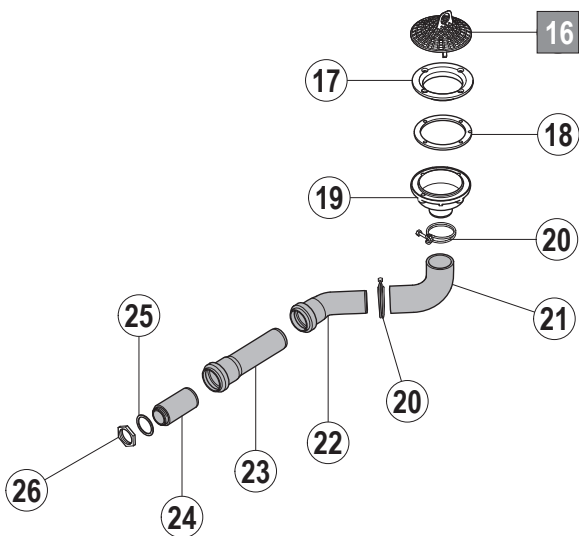
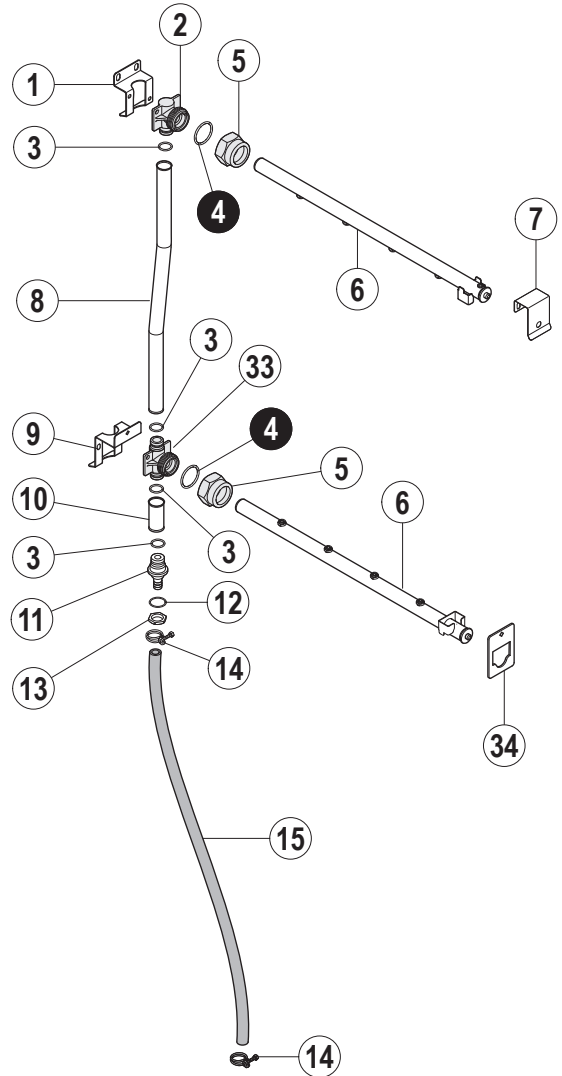
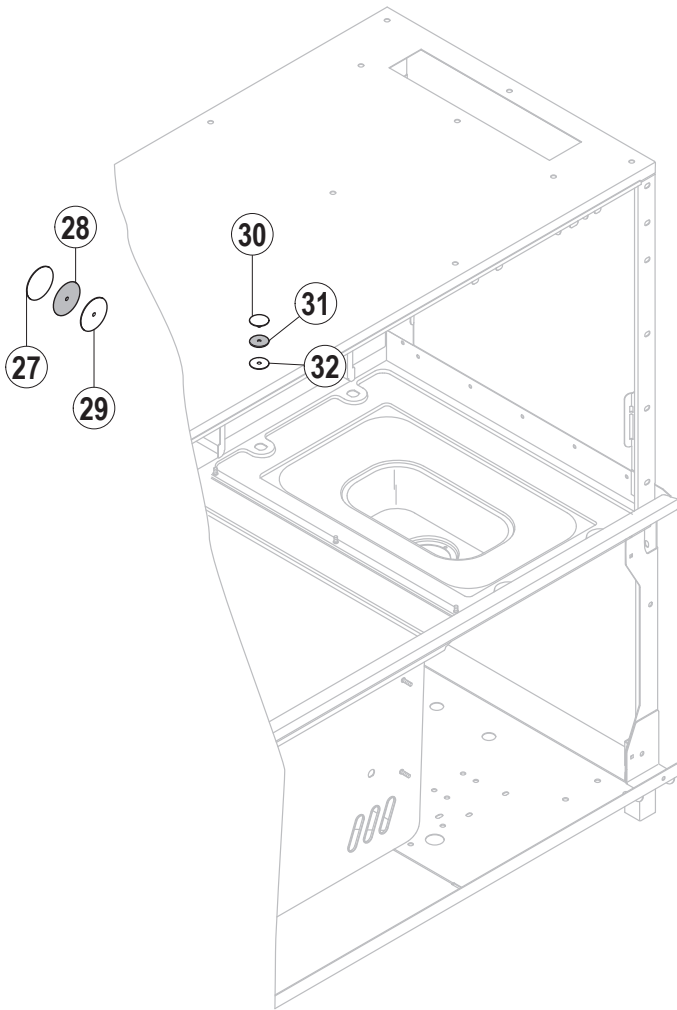

12.1

Pos.	A	B			X [mm]	Bemerkung / Remarks / Remarques
		CS	CN	CP		
01		01-291337-001	=	---		
02		01-245318-002	=	---		
03		01-245340-001	=	---		
04		00-884505-002	=	---		
05		00-885572-001	=	---		
06		01-291340-001	=	---		Mono-Spülung / Mono rinse / Mono rinçage
		01-291340-004	=	---		Demi-Spülung / Demi rinse / Demi rinçage
07		01-245062-001	=	---		
08		01-245323-003	=	---		
09		01-291341-001	=	---		
10		01-291297-001	=	---		
11		01-245329-001	=	---		
12		01-245340-002	=	---		
13		01-172739-009	=	---		
14		00-323945-022	=	---		
15		01-245571-001	=	---		
16		00-775750-001	=	---		
17		00-324053-000	=	---		
18		00-324056-000	=	---		
19		01-291536-001	=	---		
20		00-323945-053	=	---		
21		01-291527-002	=	---		
22		00-377340-003	=	---		
23		00-325706-013	=	---		
24		00-774616-001	=	---		
25		00-172986-028	=	---		
26		00-172739-008	=	---		
27		00-869137-001	=	---		
28		00-168611-023	=	---		
29		00-696943-014	=	---		
30		00-869137-003	=	---		
31		00-168611-024	=	---		
32		00-696943-030	=	---		
33		01-245318-001	=	---		
34		01-291351-001	=	---		Mono-Spülung / Mono rinse / Mono rinçage
		01-291351-004	=	---		Demi-Spülung / Demi rinse / Demi rinçage

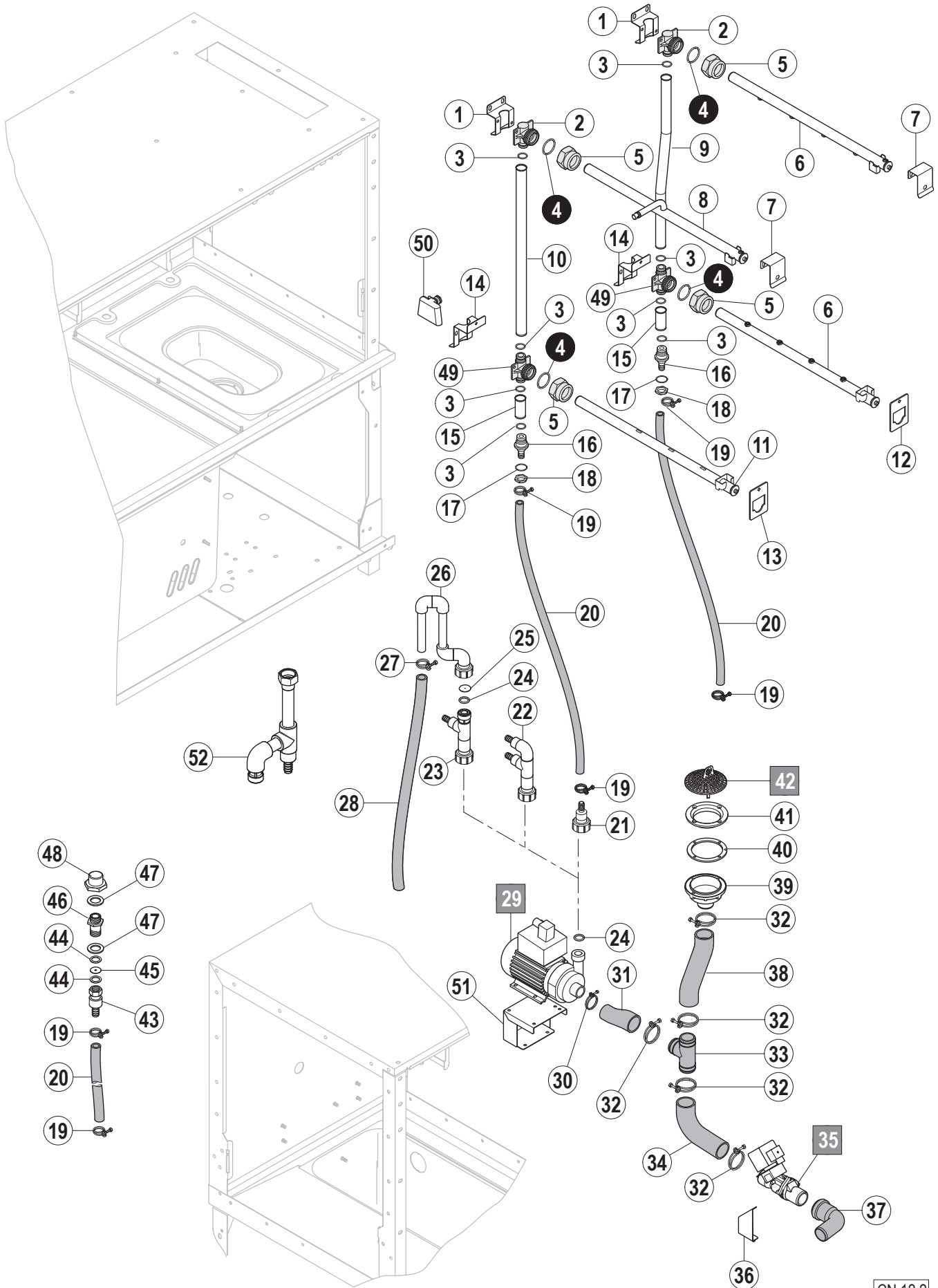

12.2

Pos.	A	B			X [mm]	Bemerkung / Remarks / Remarques
		CS	CN	CP		
01		01-291337-001	=	---		
02		01-245318-002	=	---		
03		01-245340-001	=	---		
04		00-884505-002	=	---		
05		00-885572-001	=	---		
06		01-291340-001	=	---		"Ab Serien- Nr.: 86 67 00001 siehe Kapitel 12.3 starting from serial no. 86 67 00001 see chapter 12.3 à partir du numéro de série 86 67 00001 voir le chapitre 12.3"
07		01-245062-001	=	---		
08		01-291305-001	=	---		Duo-Spülung / dual rinse / double rinçage
	L/R	---	01-291305-002	---		3-fach Spülung / triple rinse / triple rinçage
	R/L	---	01-291305-003	---		3-fach Spülung / triple rinse / triple rinçage
09		01-245323-003	=	---		"Ab Serien- Nr.: 86 67 00001 siehe Kapitel 12.3 starting from serial no. 86 67 00001 see chapter 12.3 à partir du numéro de série 86 67 00001 voir le chapitre 12.3"
10		01-291297-002	=	---		
11		01-291305-001	=	---		
12		01-291351-001	=	---		
13	L/R	01-291351-002	=	---		
	R/L	01-291351-003	=	---		
14		01-291341-001	=	---		
15		01-291297-001	=	---		
16		01-245329-001	=	---		
17		01-245340-002	=	---		
18		00-172739-009	=	---		
19		00-323945-022	=	---		
20		01-245571-001	=	---		L=1000 mm
21		00-895735-001	=	---		
22		---	01-291679-001	---		
23		---	01-291679-002	---		
24		---	00-067500-072	---		
25		---	00-699119-041	---		
26		---	01-245742-001	---		
27		---	00-323945-033	---		
28		---	00-226994-009	---		L=900 mm
29		---	00-323592-...	---		siehe Schaltplan / see wiring diagram / voir schéma de câblage
30		00-323945-040	=	---		
31		01-291526-001	=	---		
32		00-323945-053	=	---		
33		01-291562-001	=	---		
34		01-291527-001	=	---		
35		00-774683-...	=	---		siehe Schaltplan / see wiring diagram / voir schéma de câblage
36		01-291686-001	=	---		
37		00-230080-002	=	---		
38		01-291525-001	=	---		
39		01-291536-001	=	---		
40		00-324056-000	=	---		
41		00-324053-000	=	---		
42		00-775750-001	=	---		
43		---	01-245992-002	---		
44		---	00-172986-034	---		

Pos.	A	B			X [mm]	Bemerkung / Remarks / Remarques
		CS	CN	CP		
45		---	01-245857-005	---		
46		---	00-227931-000	---		
47		---	00-172986-027	---		
48		---	00-774670-001	---		
49		---	01-245318-001	---		
50		00-324858-001	=	---		
51		01-296093-001	=	---		
52		---	01-247089-001	---		

12.3

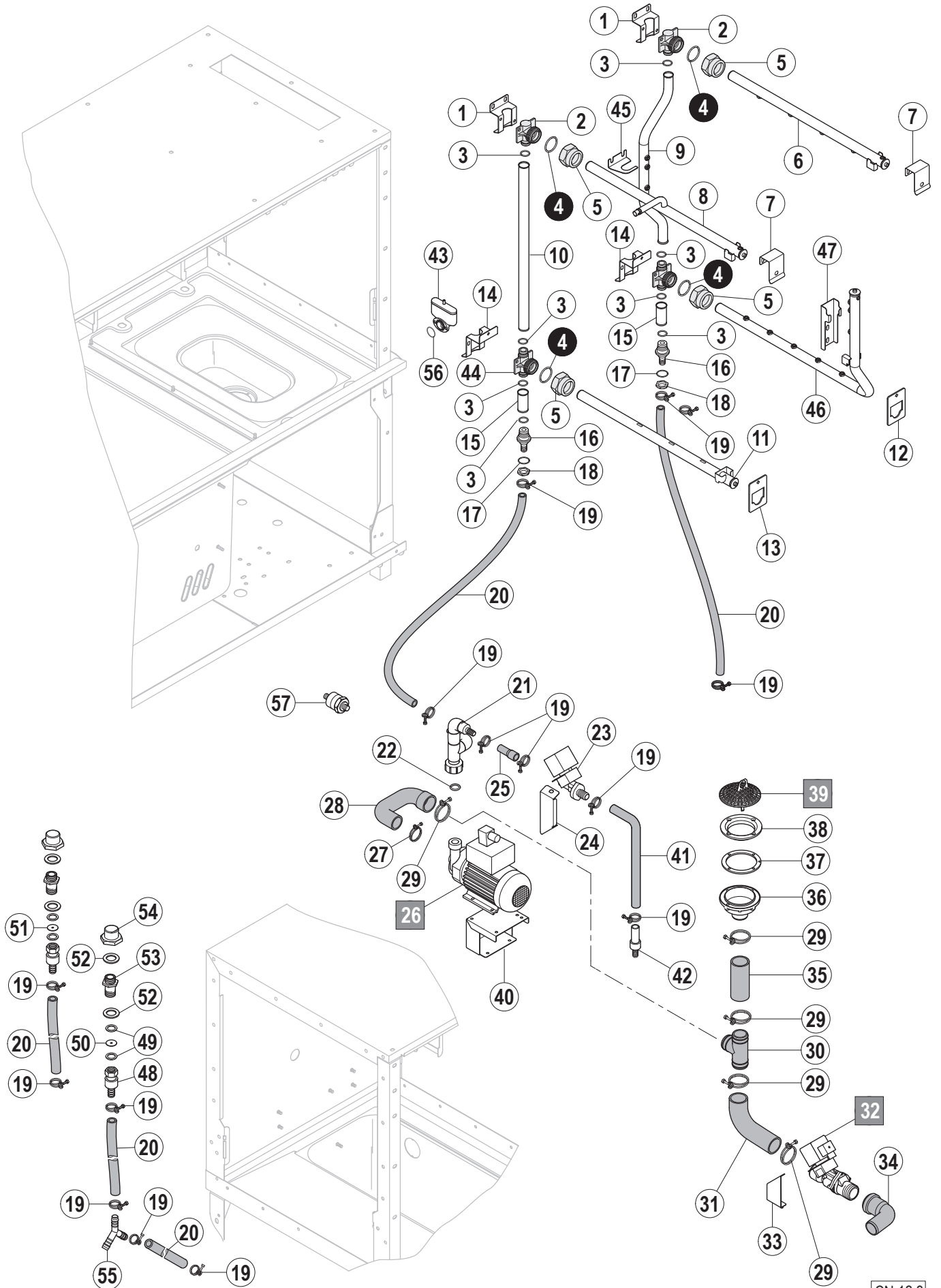

Pos.	A	B			X [mm]	Bemerkung / Remarks / Remarques
		CS	CN	CP		
01		---	---	01-291337-001		
02		---	---	01-245318-002		
03		---	---	01-245340-001		
04		---	---	00-884505-002		
05		---	---	00-885572-001		
06		---	---	01-291340-002		
07		---	---	01-245062-001		
08	L/R	---	---	01-291305-002		
	R/L	---	---	01-291305-003		
09	L/R	---	---	01-291353-001		
	R/L	---	---	01-291355-001		
10		---	---	01-291297-002		
11		---	---	01-291305-001		
12		---	---	01-291351-001		
13	L/R	---	---	01-291351-002		
	R/L	---	---	01-291351-003		
14		---	---	01-291341-001		
15		---	---	01-291297-001		
16		---	---	01-245329-001		
17		---	---	01-245340-002		
18		---	---	00-172739-009		
19		---	---	00-323945-022		
20		---	---	01-245571-001		L=1000 mm
21	L/R	---	---	01-291679-003		ohne / without / sans Pos. 57
	R/L	---	---	01-291679-004		ohne / without / sans Pos. 57
	L/R	---	---	01-291679-007		mit / with / avec Pos. 57
	R/L	---	---	01-291679-008		mit / with / avec Pos. 57
22		---	---	00-067500-072		
23		---	---	00-323592-...		siehe Schaltplan / see wiring diagram / voir schéma de câblage
24	L/R	---	---	01-291689-001		
	R/L	---	---	01-291687-001		
25		---	---	00-887667-002		
26		---	---	00-781237-...		siehe Schaltplan / see wiring diagram / voir schéma de câblage
27		---	---	00-323945-040		
28		---	---	01-291691-001		
29		---	---	00-323945-053		
30		---	---	01-291562-001		
31		---	---	01-291527-001		
32		---	---	00-774683-...		siehe Schaltplan / see wiring diagram / voir schéma de câblage
33		---	---	01-291686-001		
34		---	---	00-230080-002		
35		---	---	01-291525-002		
36		---	---	01-291536-001		
37		---	---	00-324056-000		
38		---	---	00-324053-000		
39		---	---	00-775750-001		
40		---	---	01-296093-001		
41		---	---	00-324077-026		
42		---	---	00-897679-003		
43		---	---	01-240076-002		

Pos.	A	B			X [mm]	Bemerkung / Remarks / Remarques
		CS	CN	CP		
44		---	---	01-245318-001		
45		---	---	01-291346-001		
46	L/R	---	---	01-291345-001		
	R/L	---	---	01-291350-001		
47		---	---	01-291347-001		
48		---	---	01-245992-002		
49		---	---	00-172986-034		
50		---	---	01-245857-003		Blende AR-Waschung / diaphragm AR wash / diaphragme AR lavage
51		---	---	01-245857-004		Blende Vorwaschung / diaphragm prewash / diaphragme pré-lavage
52		---	---	00-172986-027		
53		---	---	00-227931-000		
54		---	---	00-774670-001		
55		---	---	00-174047-001		
56		---	---	00-276903-056		
57	---	---	---	01-297200-001		

CS / CN / CP

Füllsystem

Filling system

Système de remplissage

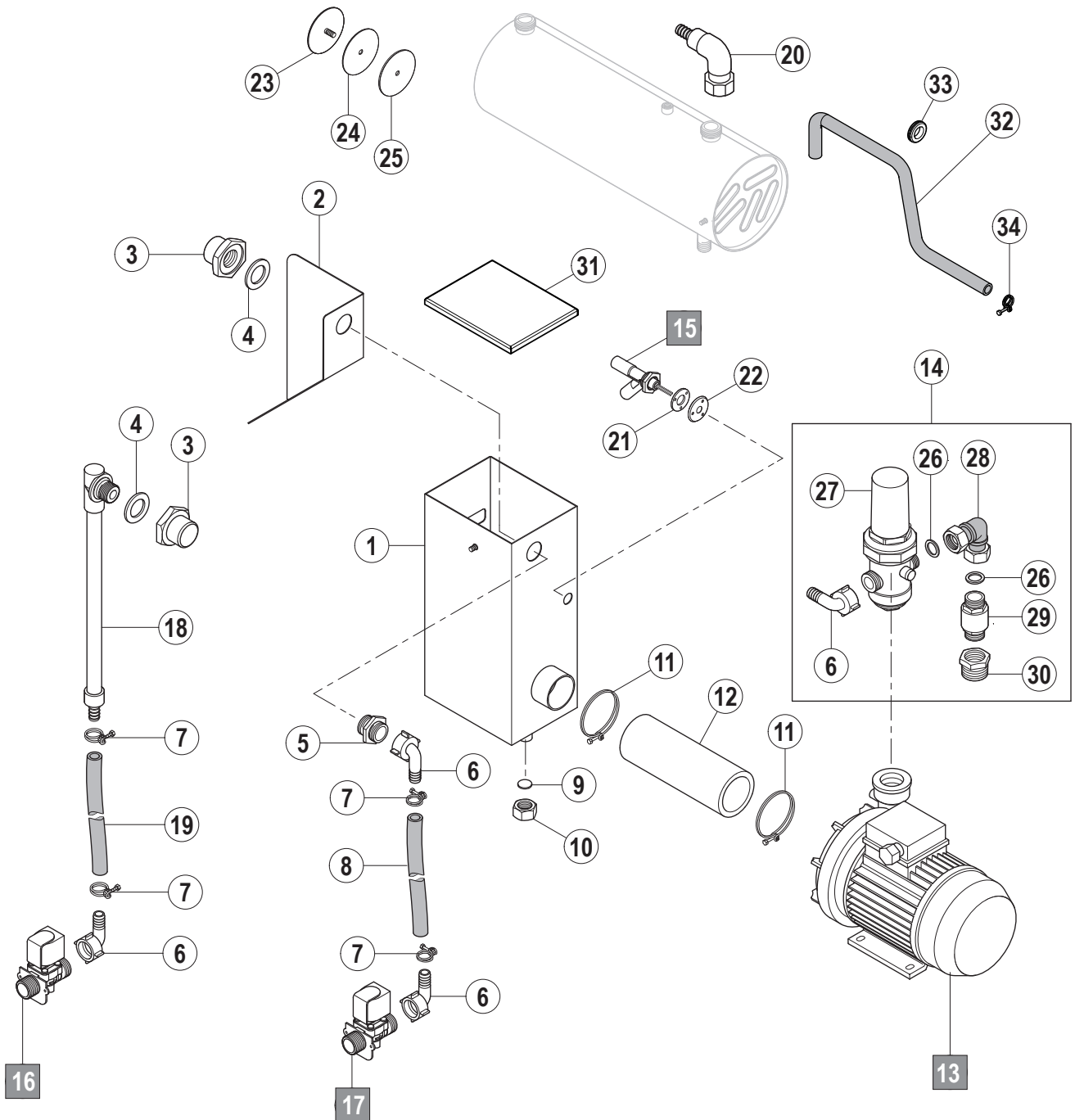

13.1

Pos.	A	B			X [mm]	Bemerkung / Remarks / Remarques
		CS	CN	CP		
01		01-291436-002	=	---		
02		01-291662-001	=	---		
03		00-774670-001	=	---		
04		00-172986-027	=	---		
05		00-227931-000	=	---		
06		00-299240-001	=	---		
07		00-323945-022	=	---		
08		01-245571-013	=	---		L=1200 mm
09		00-168611-022	=	---		
10		00-600588-000	=	---		
11		00-323945-064	=	---		
12		00-883142-006	=	---		
13		00-897662-...	=	---		siehe Schaltplan / see wiring diagram / voir schéma de câblage
14		01-291709-001	=	---		
15		00-735171-...	=	---		siehe Schaltplan / see wiring diagram / voir schéma de câblage
16		00-297808-012	=	---		Warmwasser / hot water / eau chaude
17		00-297808-010	=	---		Kaltwasser / cold water / eau froide
18		00-897686-001	=	---		
19		01-245571-002	=	---		L=2000 mm
20		01-296696-001	=	---		
21		00-774034-001	=	---		
22		00-774010-001	=	---		
23		00-869137-001	=	---		
24		00-168611-023	=	---		
25		00-696943-014	=	---		
26		00-168611-009	=	---		
27		00-229110-002	=	---		
28		01-291708-001	=	---		
29		00-897668-001	=	---		
30		00-603076-000	=	---		
31		01-291152-005	=	---		
32		01-518215-001	=	---		
33		00-227748-014	=	---		
34		00-323945-020	=	---		

13.2

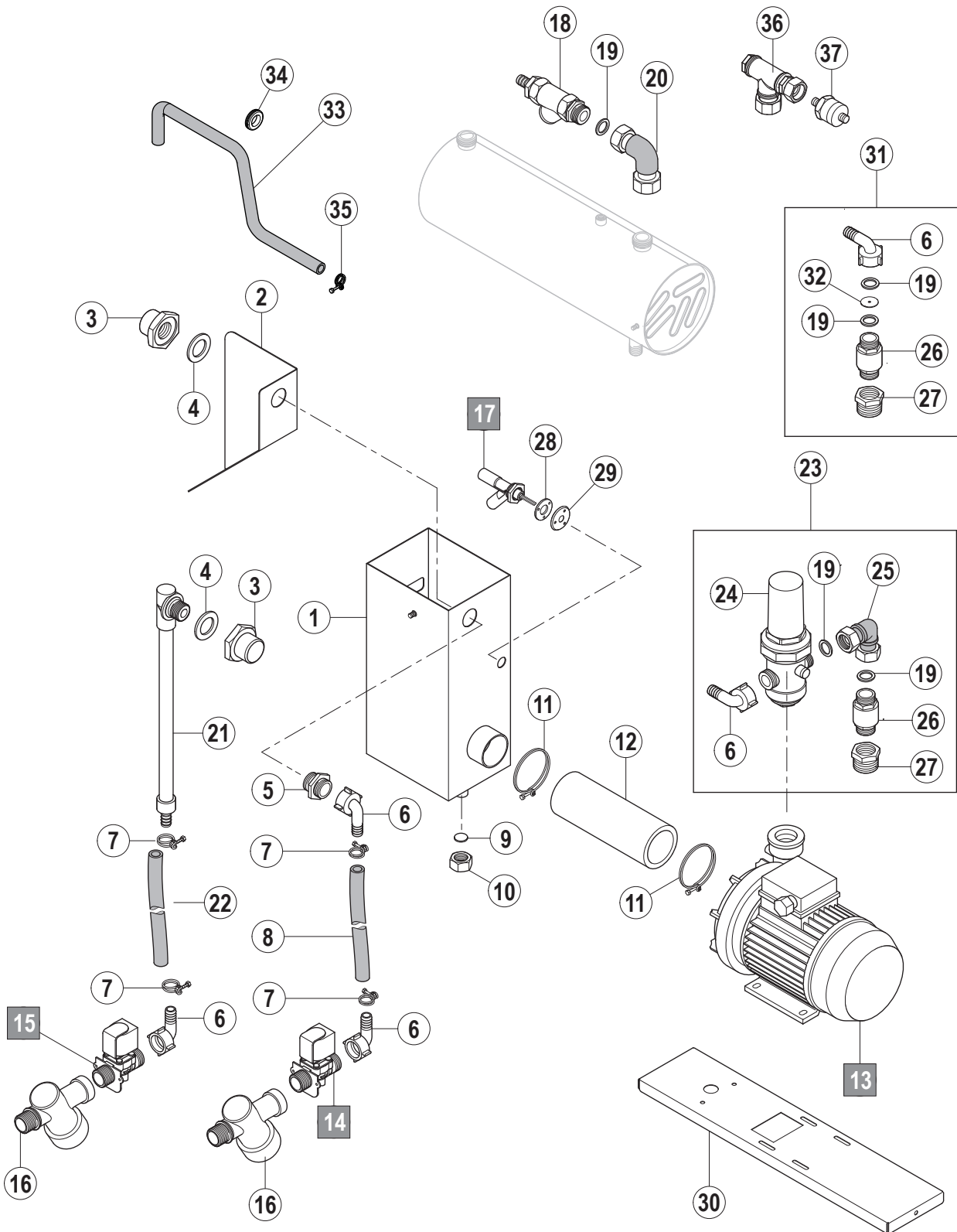

Pos.	A	B			X [mm]	Bemerkung / Remarks / Remarques
		CS	CN	CP		
01		---	---	01-291436-001		
02		---	---	01-291662-001		
03		---	---	00-774670-001		
04		---	---	00-172986-027		
05		---	---	00-227931-000		
06		---	---	00-299240-001		
07		---	---	00-323945-022		
08		---	---	01-245571-013		L=1200 mm
09		---	---	00-168611-022		
10		---	---	00-600588-000		
11		---	---	00-323945-068		
12		---	---	00-883142-006		
13		---	---	00-897662-...		siehe Schaltplan / see wiring diagram / voir schéma de câblage
14		---	---	00-297808-012		Warmwasser / hot water / eau chaude
15		---	---	00-297808-010		Kaltwasser / cold water / eau froide
16		---	---	00-774810-001		
17		---	---	00-735171-...		siehe Schaltplan / see wiring diagram / voir schéma de câblage
18		---	---	01-243891-002		
19		---	---	00-168611-009		
20		---	---	01-296696-002		
21		---	---	00-897686-001		
22		---	---	01-245571-002		L=2000 mm
23		---	---	01-291709-001		ohne SENSOTRONIC / without SENSOTRONIC / sans SENSOTRONIC
24		---	---	00-229110-002		
25		---	---	01-291708-001		
26		---	---	00-897668-001		
27		---	---	00-603076-000		
28		---	---	00-774034-001		
29		---	---	00-774010-001		
30		---	---	01-296094-001		
31		---	---	01-291709-003		mit SENSOTRONIC / with SENSOTRONIC / avec SENSOTRONIC
32		---	---	01-245857-006		
33		---	---	01-518215-001		
34		---	---	00-227748-014		
35		---	---	00-323945-020		
36		---	---	01-296696-005		
37		---	---	01-297200-001		

13.3

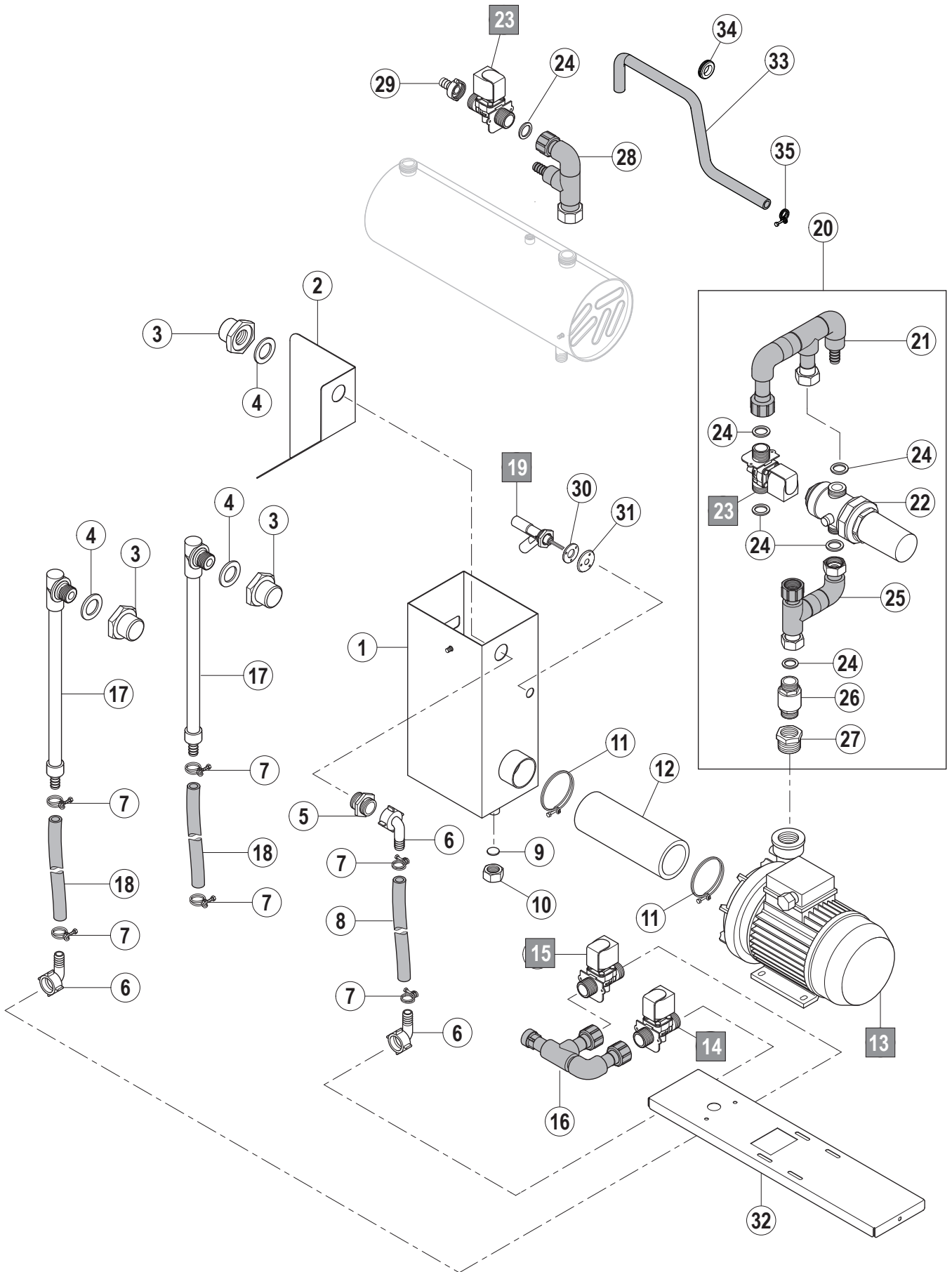

Pos.	A	B			X [mm]	Bemerkung / Remarks / Remarques
		CS	CN	CP		
01		---	01-291436-001	---		
02		---	01-291662-001	---		
03		---	00-774670-001	---		
04		---	00-172986-027	---		
05		---	00-227931-000	---		
06		---	00-299240-001	---		
07		---	00-323945-022	---		
08		---	01-245571-013	---		L=1200 mm
09		---	00-168611-022	---		
10		---	00-600588-000	---		
11		---	00-323945-064	---		
12		---	00-883142-006	---		
13		---	00-897662-...	---		siehe Schaltplan / see wiring diagram / voir schéma de câblage
14		---	00-297808-007	---		Kaltwasser / cold water / eau froide
15		---	00-297808-012	---		Warmwasser / hot water / eau chaude
16		---	00-775112-...	---		siehe Schaltplan / see wiring diagram / voir schéma de câblage
17		---	00-897686-001	---		
18		---	01-245571-002	---		L=2000 mm
19		---	00-735171-002	---		
20		---	01-291709-002	---		
21		---	01-245694-002	---		
22		---	00-229110-002	---		
23		---	00-297808-008	---		
24		---	00-168611-009	---		
25		---	01-245693-001	---		
26		---	00-897668-001	---		
27		---	00-603076-000	---		
28		---	01-296696-004	---		
29		---	00-302201-001	---		
30		---	00-774034-001	---		
31		---	00-774010-001	---		
32		---	01-296094-001	---		
33		---	01-518215-001	---		
34		---	00-227748-014	---		
35		---	00-323945-020	---		

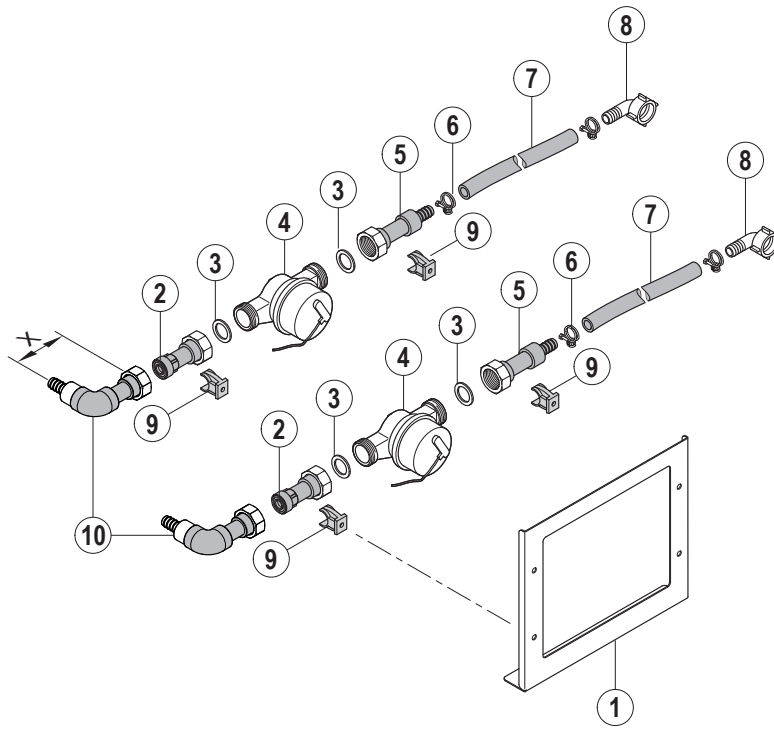

13.4

Pos.	A	B			X [mm]	Bemerkung / Remarks / Remarques
		CS	CN	CP		
01		01-291298-001	=	=		
02		01-291004-002	=	=		
03		00-168611-003	=	=		
04		01-244744-002	=	=		
05		01-291004-006	=	=		
06		00-323945-022	=	=		
07		01-245571-014	=	=		L=500 mm
08		00-299240-001	=	=		
09		00-228810-002	=	=		
10		01-291004-008	=	=	72	
		01-291004-009	=	=	87	

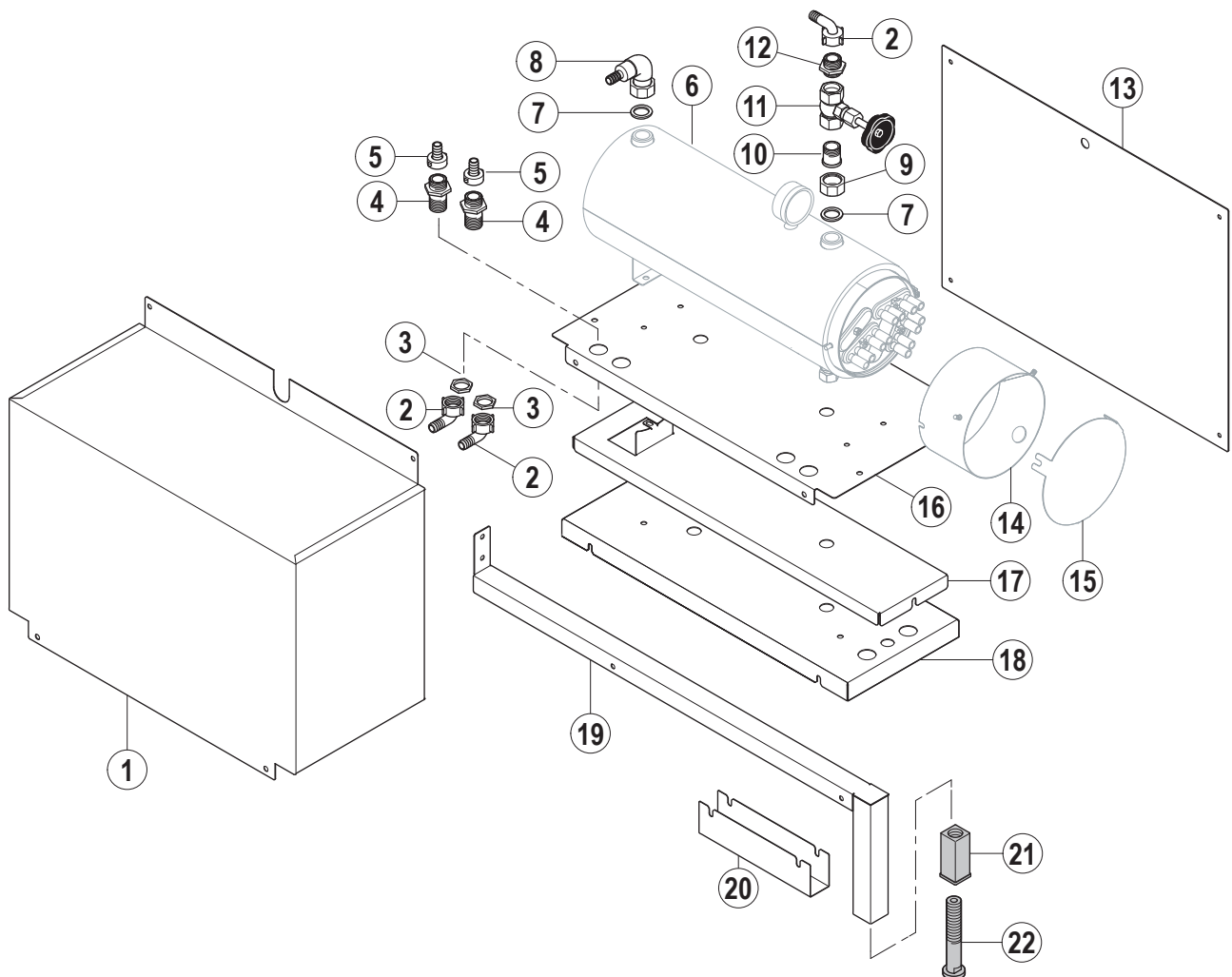

13.5

Pos.	A	B			X [mm]	Bemerkung / Remarks / Remarques
		CS	CN	CP		
01		---	01-242110-001	=		Nur bei CDS / (CDC bis Serien-Nr.: 8646 7490)
		---	01-242110-004	=		Nur bei CDC-C -Trocknung
		---	01-518280-001	=		Nur bei CDC ab Serien-Nr.: 8646 7491
02		---	00-299240-001	=		
03		---	00-172739-002	=		
04		---	01-245850-001	=		
05		---	00-302201-001	=		
06		---	01-291554-...	=		Boiler siehe Schaltplan / Booster see wiring diagram / Chaudière voir schéma de câblage
07		---	00-168611-003	=		
08		---	01-296696-001	=		
09		---	00-600806-000	=		
10		---	00-602403-000	=		
11		---	01-241853-002	=		
12		---	00-227931-000	=		
13		---	01-242129-001	=		Nur bei CDS
		---	01-242129-002	=		Nur bei CDC-C -Trocknung
		---	01-242129-003	=		Nur bei CDC ab Serien-Nr.: 8646 7491
14		---	01-249044-001	=		
15		---	01-296351-001	=		
16		---	01-296271-001	=		nur bei CDS -Trocknung / only CDS -Dryer / seulement CDS -Séchage
		---	01-296271-002	=		nur bei CDC-C -Trocknung / only CDC-C -Dryer / seulement CDC-C -Séchage
17		---	01-245923-004	=		nur bei DS -Trocknung / only DS -Dryer / seulement DS -Séchage
18		---	01-242120-004	=		nur bei CDC -Trocknung / only CDC -Dryer / seulement CDC -Séchage
19		---	01-296221-001	=		nur bei CDC -Trocknung / only CDC -Dryer / seulement CDC -Séchage
20		---	01-243861-001	=		nur bei CDC -Trocknung / only CDC -Dryer / seulement CDC -Séchage
21		---	00-325008-001	=		
22		---	00-325007-001	=		

CS / CN / CP

Wärmerückgewinnung

Heat recovery

Récupération de la chaleur

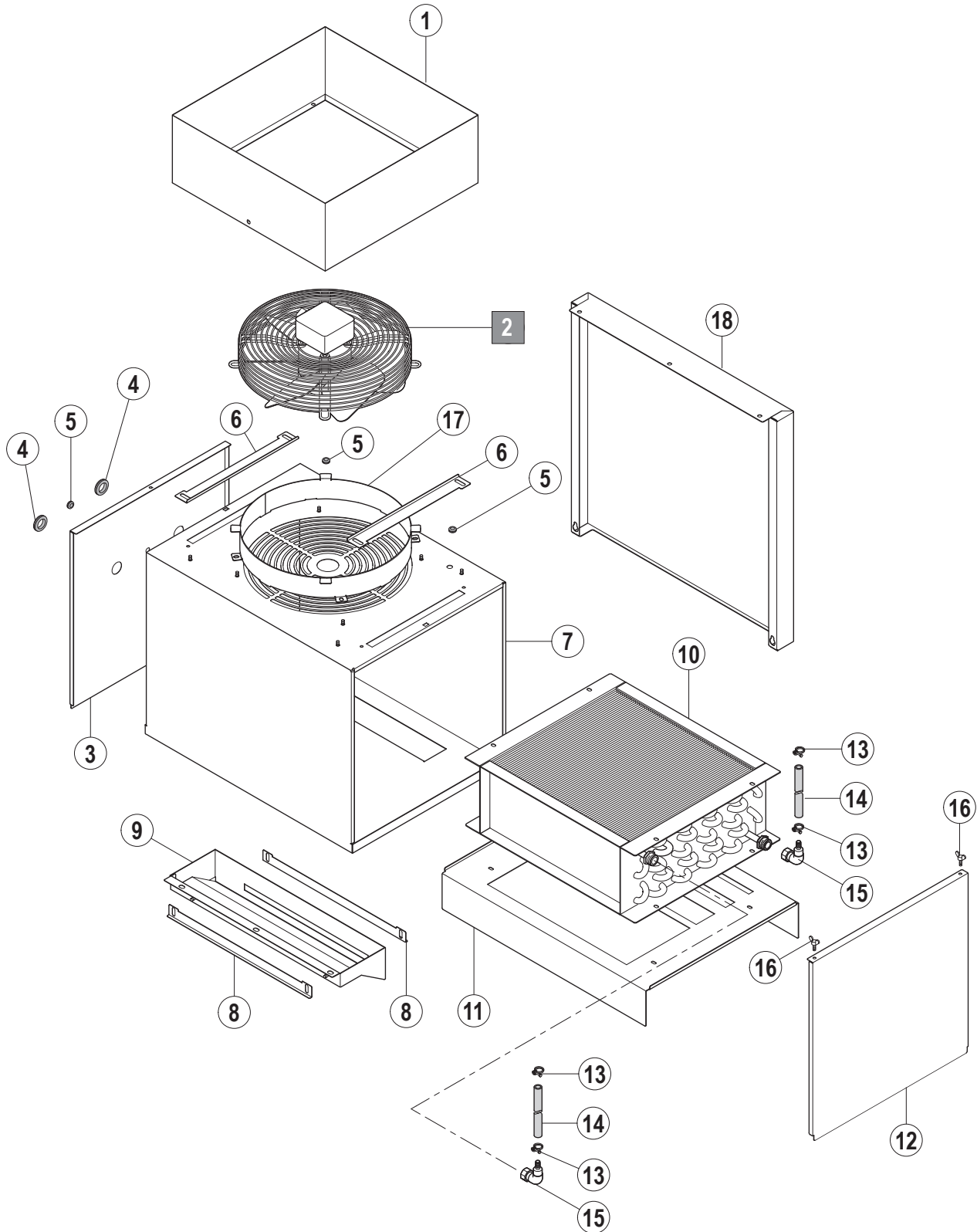

14.1

CN 14.1

Pos.	A	B			X [mm]	Bemerkung / Remarks / Remarques
		CS	CN	CP		
01		---	01-245744-002	=		
02		---	00-781492-...	=		siehe Schaltplan / see wiring diagram / voir schéma de câblage
03		---	01-245206-003	=		
04		---	00-227748-004	=		
05		---	00-227748-001	=		
06		---	01-291395-002	=		
07		---	01-291392-001	=		
08		---	01-291395-001	=		
09	L/R	---	01-291394-001	=		
	R/L	---	01-291394-002	=		
10		---	01-245490-007	=		standard
		---	01-245490-008	=		CrNi / SST / inox
11		---	01-245274-004	=		
12		---	01-245206-001	=		
13		---	00-323945-022	=		
14		---	01-245571-002	=		L=2000 mm
15		---	00-299240-001	=		
16		---	00-609851-000	=		
17		---	00-781377-002	=		
18		---	01-296449-001	=		

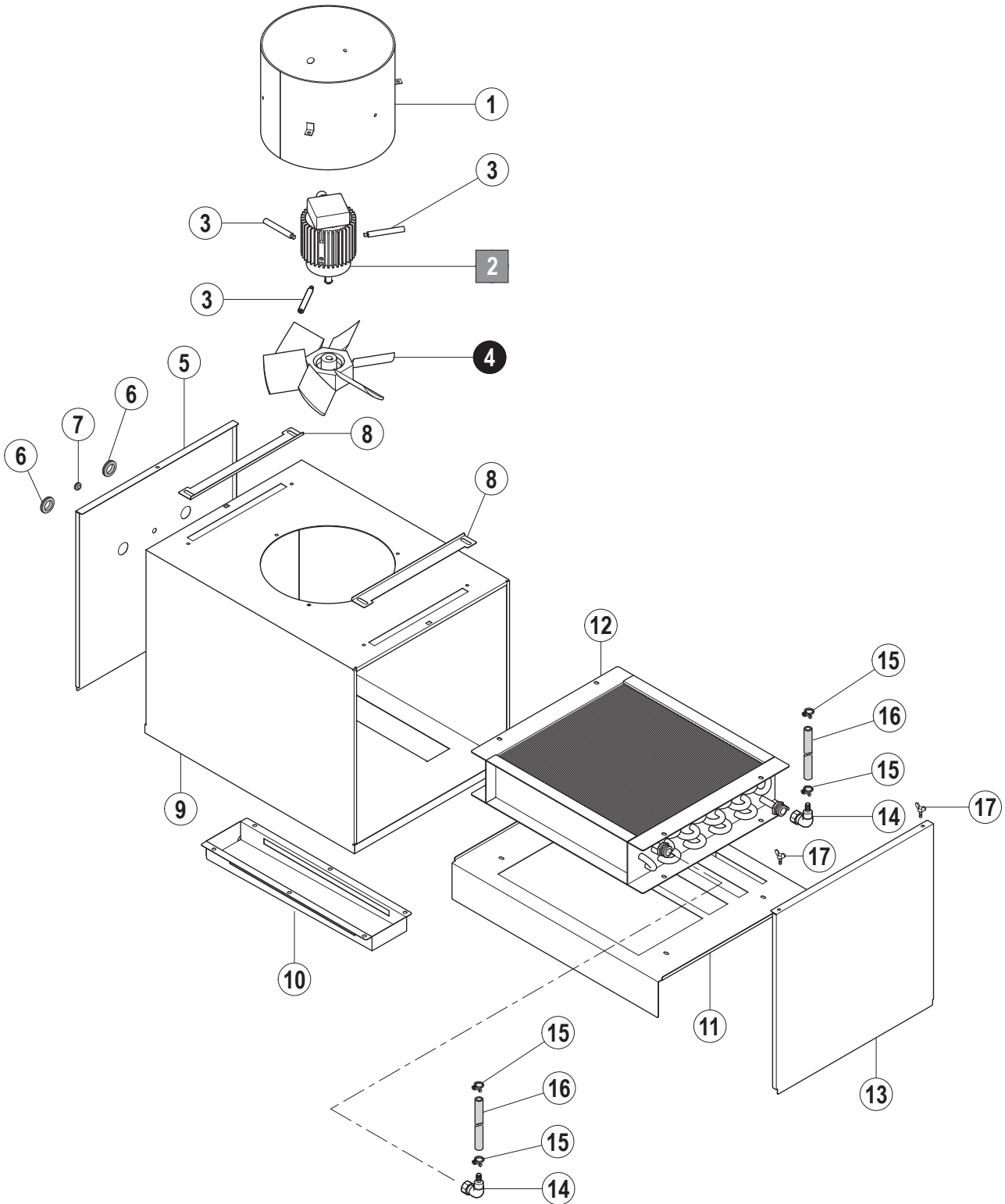

14.2

CN 14.2a

Pos.	A	B			X [mm]	Bemerkung / Remarks / Remarques
		CS	CN	CP		
01		00-229438-001	---	---		
02		00-145075-...	---	---		siehe Schaltplan / see wiring diagram / voir schéma de câblage
03		00-693877-002	---	---		
04		00-038933-001	---	---		
05		01-245206-003	---	---		
06		00-227748-004	---	---		
07		00-227748-001	---	---		
08		00-228336-000	---	---		
09		01-291392-002	---	---		
10		01-291796-001	---	---		
11		01-245274-004	---	---		
12		01-291833-001	---	---		
13		01-245206-001	---	---		
14		00-299240-001	---	---		
15		00-323945-022	---	---		
16		01-245571-002	---	---		L=2000 mm
17		00-609851-000	---	---		

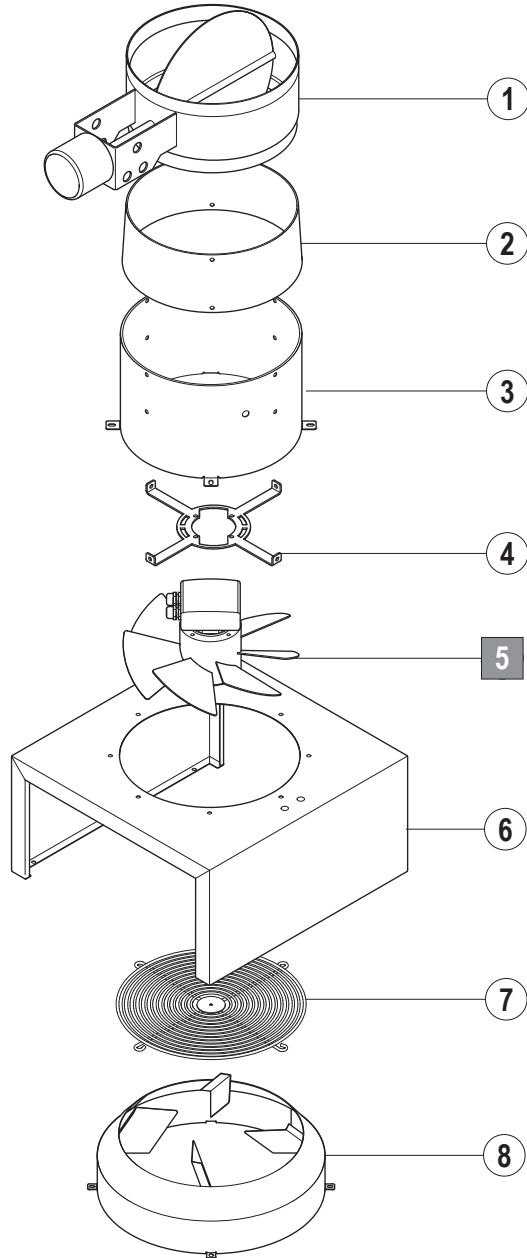

14.3

CN 14.3

Pos.	A	B			X [mm]	Bemerkung / Remarks / Remarques
		CS	CN	CP		
01		---	00-296927-...	=		siehe Schaltplan / see wiring diagram / voir schéma de câblage
02		---	01-245752-001	=		
03		---	01-245746-001	=		
04		---	01-245747-001	=		
05		---	00-775078-...	=		siehe Schaltplan / see wiring diagram / voir schéma de câblage
06		---	01-245745-003	=		
07		---	00-896396-001	=		
08		---	00-781353-001	=		

CS / CN / CP
Wärmepumpe
Heat pump
Pompe à chaleur

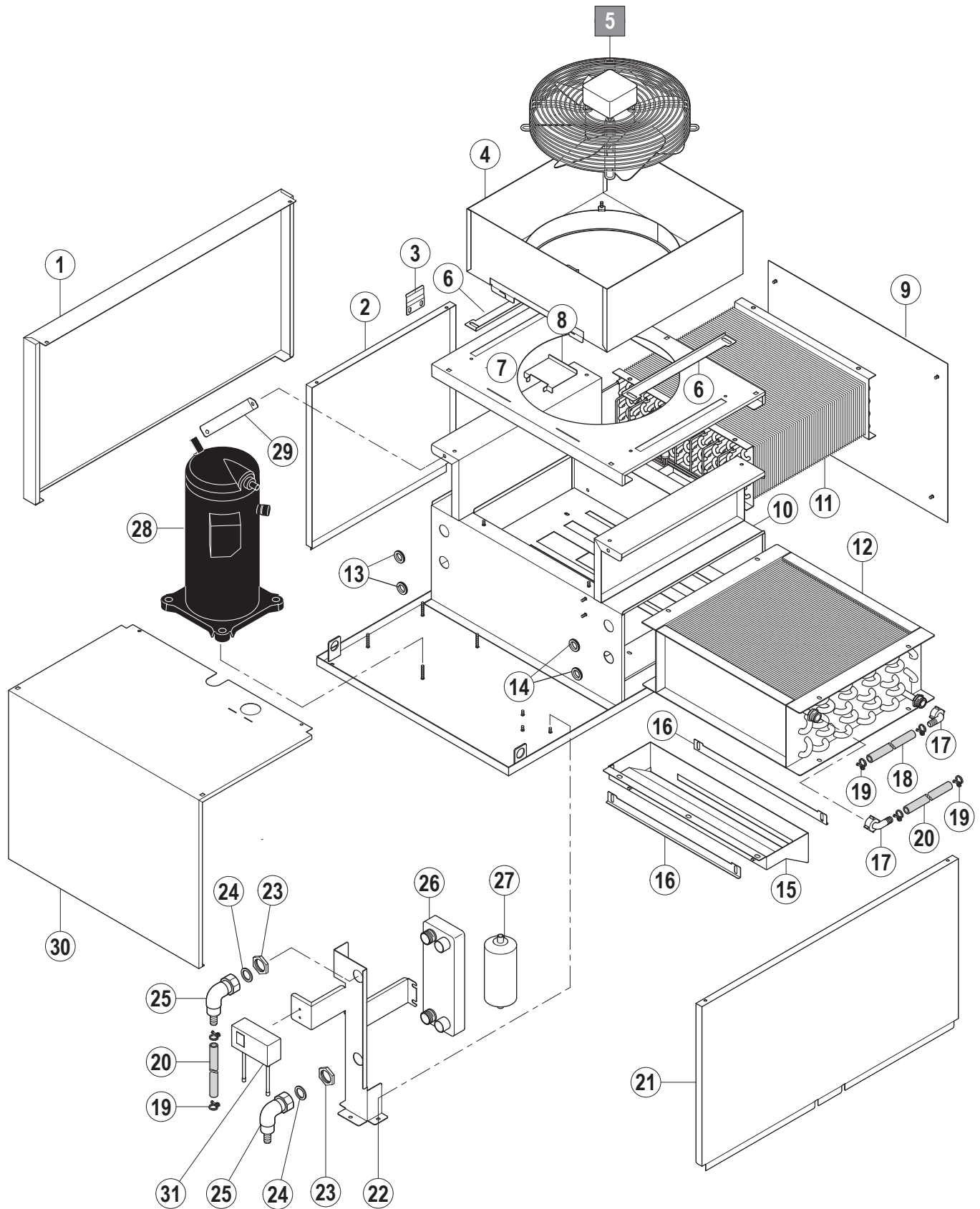

15.1

CN 15.1

Pos.	A	B			X [mm]	Bemerkung / Remarks / Remarques
		CS	CN	CP		
01		---	01-291604-001	=		
02		---	01-296226-001	=		
03		---	01-291605-001	=		
04		---	01-291595-001	=		
05		---	00-781492-...	=		siehe Schaltplan / see wiring diagram / voir schéma de câblage
06		---	01-291395-002	=		
07		---	01-291589-001	=		
08		---	01-291837-001	=		
09		---	01-291593-001	=		
10		---	01-291588-001	=		
11		---	00-887639-001	=		
12		---	01-245490-007	=		
13		---	00-785565-004	=		
14		---	00-227748-004	=		
15	L/R	---	01-291394-001	=		
	R/L	---	01-291394-002	=		
16		---	01-291395-001	=		
17		---	00-299240-001	=		
18		---	01-245571-014	=		L=500 mm
19		---	00-323945-022	=		
20		---	01-245571-002	=		L=2000 mm
21		---	01-245548-001	=		
22		---	01-245549-001	=		
23		---	00-172739-008	=		
24		---	00-168611-003	=		
25		---	01-245560-001	=		
26		---	00-323456-001	=		
27		---	00-323443-000	=		
28		---	00-323437-...	=		siehe Schaltplan / see wiring diagram / voir schéma de câblage
29		---	01-245722-001	=		
30		---	01-291591-001	=		
31		---	01-296704-001	=		

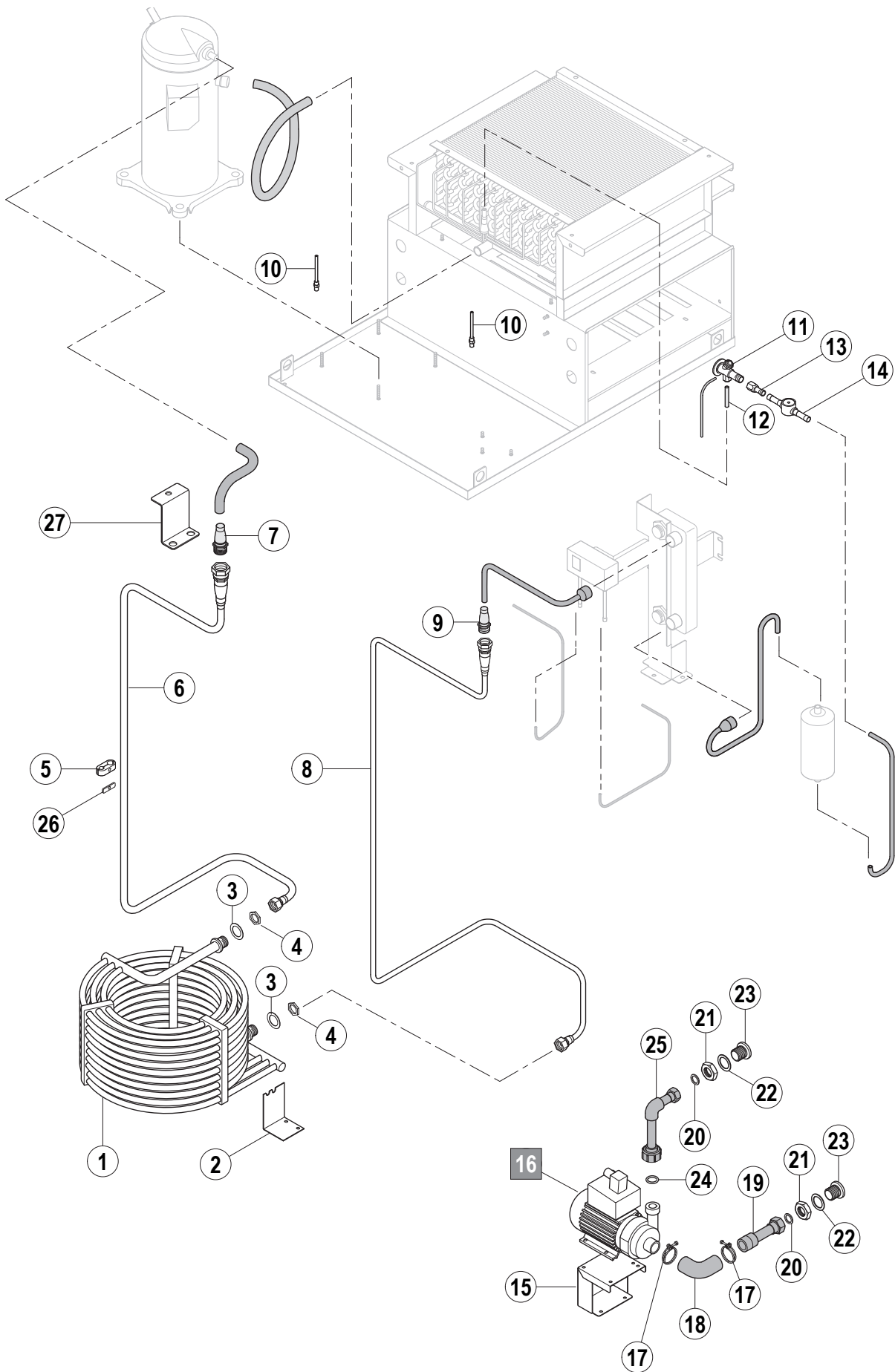

15.2

Pos.	A	B			X [mm]	Bemerkung / Remarks / Remarques
		CS	CN	CP		
01		---	01-291581-001	=		
02		---	01-296021-001	=		
03		---	00-696936-018	=		
04		---	00-172739-013	=		
05		---	00-897282-001	=		
06	L/R	---	01-291598-001	=		
	R/L	---	01-291606-001	=		
07		---	00-896909-001	=		
08	L/R	---	01-291599-001	=		
	R/L	---	01-291607-001	=		
09		---	00-775080-001	=		
10		---	00-323447-000	=		
11		---	00-775082-001	=		
12		---	00-323439-003	=		bei Kompressor ZR-61/ZR48 / with compressor ZR61/ZR48 / chez compresseur ZR61/ZR48
		---	00-323439-004	=		bei Kompressor ZR72 / by compressor ZR72 / chez compresseur ZR72
13		---	00-324439-002	=		
14		---	00-323444-000	=		
15		---	01-296093-002	=		
16		---	00-781237-...	=		siehe Schaltplan / see wiring diagram / voir schéma de câblage
17		---	00-323945-043	=		
18		---	00-781336-004	=		
19		---	01-291664-001	=		
20		---	00-168611-009	=		
21		---	00-603061-000	=		
22		---	00-300084-007	=		
23		---	00-774953-001	=		
24		---	00-067500-072	=		
25	L/R	---	01-291665-001	=		
	R/L	---	01-291665-002	=		
26		---	00-897285-001	=		
27		---	01-296658-001	=		

CS / CN / CP
Transportsystem
Transport system
Système de convoyage

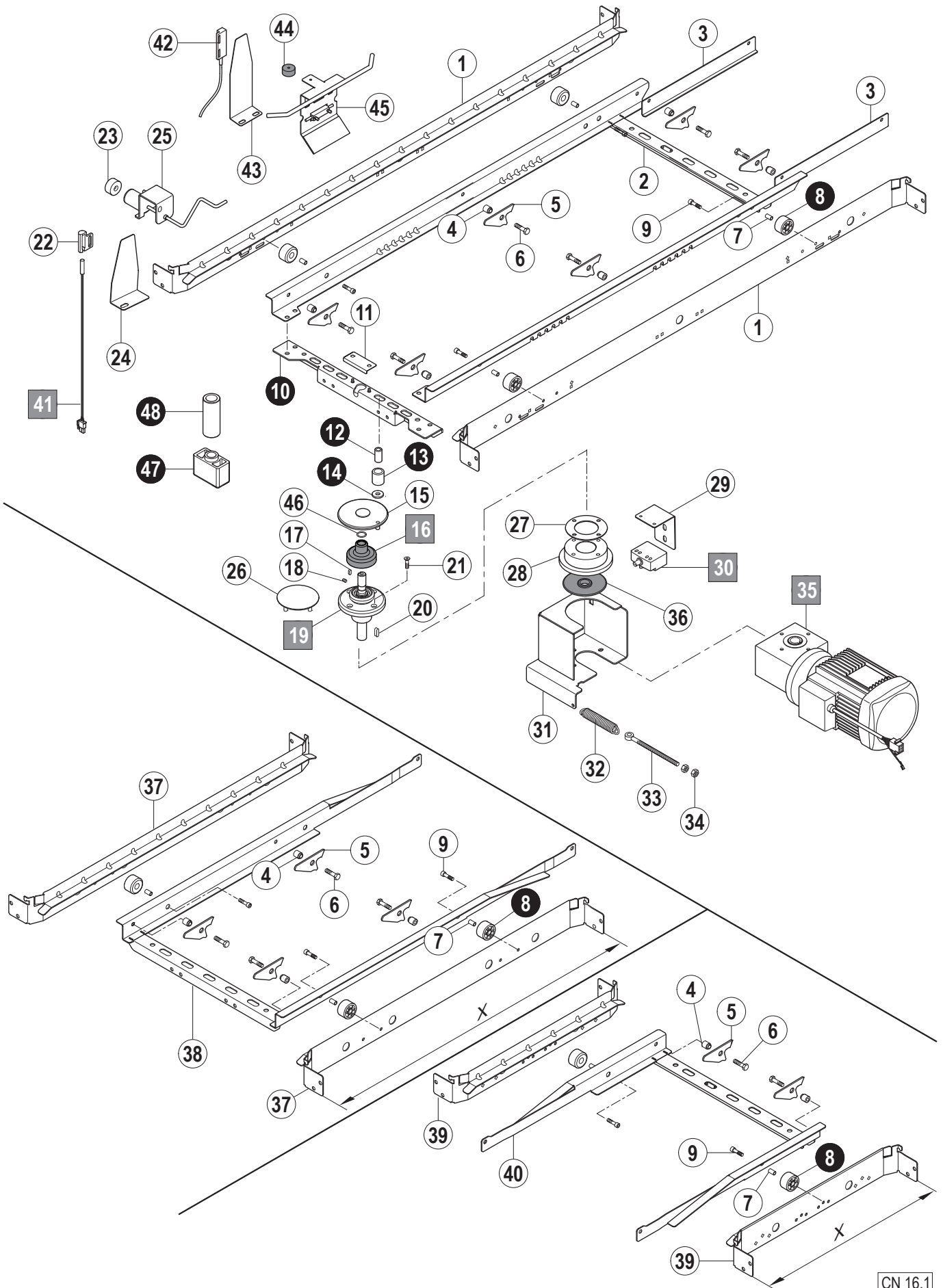

16.1

CN 16.1

Pos.	A	B			X [mm]	Bemerkung / Remarks / Remarques
		CS	CN	CP		
01		01-291368-001	=	=		
02		01-291375-001	=	=		
03		---	01-291881-001	=		SN-Modul
04		01-243284-001	=	=		
05		01-291371-001	=	=		
06		00-602579-000	=	=		
07		01-291535-001	=	=		
08		01-291534-001	=	=		
09		00-603026-000	=	=		
10		01-291772-001	=	=		
11		00-868312-001	=	=		
12		00-154795-000	=	=		
13		00-154789-000	=	=		
14		00-781490-001	=	=		
15		00-781117-001	=	=		
16		01-296445-001	=	=		
17		00-600681-000	=	=		
18		00-600682-000	=	=		
19		00-781064-004	=	=		
20		00-600683-000	=	=		
21		00-609794-000	=	=		
22		---	00-883838-001	=		
23		---	00-774714-001	=		
24		---	01-291513-001	=		
	L/R	---	01-291774-001	=		E-Modul
	R/L	---	01-291774-002	=		E-Modul
25	L/R	---	01-242189-001	=		
	R/L	---	01-242189-002	=		
26		---	00-899210-001	=		SN-Modul
27		00-781007-001	=	=		
28		01-291529-001	=	=		
29		01-291387-001	=	=		
30		00-785286-001	=	=		
31	L/R	01-291888-001	=	=		
	R/L	01-291888-002	=	=		
32		00-774828-002	=	=		
33		00-602920-000	=	=		
34		00-603488-000	=	=		
35		01-291291-...	=	=		siehe Schaltplan / see wiring diagram / voir schéma de câblage
36		01-241802-001	=	=		
37		01-291368-004	=	=	500	E-Modul
		---	01-291368-003	=	650	L-Modul
		---	01-291368-002	=	900	S-Modul
38		01-291375-004	=	=	500	E-Modul
		---	01-291375-003	=	650	L-Modul
		---	01-291375-002	=	900	S-Modul

Pos.	A	B			X [mm]	Bemerkung / Remarks / Remarques
		CS	CN	CP		
39		---	01-291368-005	=	850	CDS /DS
		---	01-291368-006	=	450	ND
		01-291368-003	---	---	650	D- Trocknung / D- dryer / D- séchage
		---	01-291368-009	=	650	Spülmodul / rinse module / module de rinçage
		---	01-291368-004	=	500	Demi-Spülung / Demi rinse / demi rinçage
40		---	01-291375-005	=	850	CDS / DS
		---	01-291375-006	=	450	ND
		01-291375-003	=	=	650	D- Trocknung / D- dryer / D- séchage
		---	01-291375-008	=	650	Spülmodul / rinse module / module de rinçage
		---	01-291375-004	=	500	Demi-Modul / demi module / demi module
41		---	01-240288-001	=		
42		00-229517-000	---	---		
43		01-291804-001	---	---		
44		00-774714-001	---	---		
45		01-291802-001	---	---		
46		00-276903-007	=	=		
47		01-296150-001	=	=		
48		01-296149-001	=	=		

CS / CN / CP

Türen und Verkleidungen

Doors and panels

Portes et panneaux

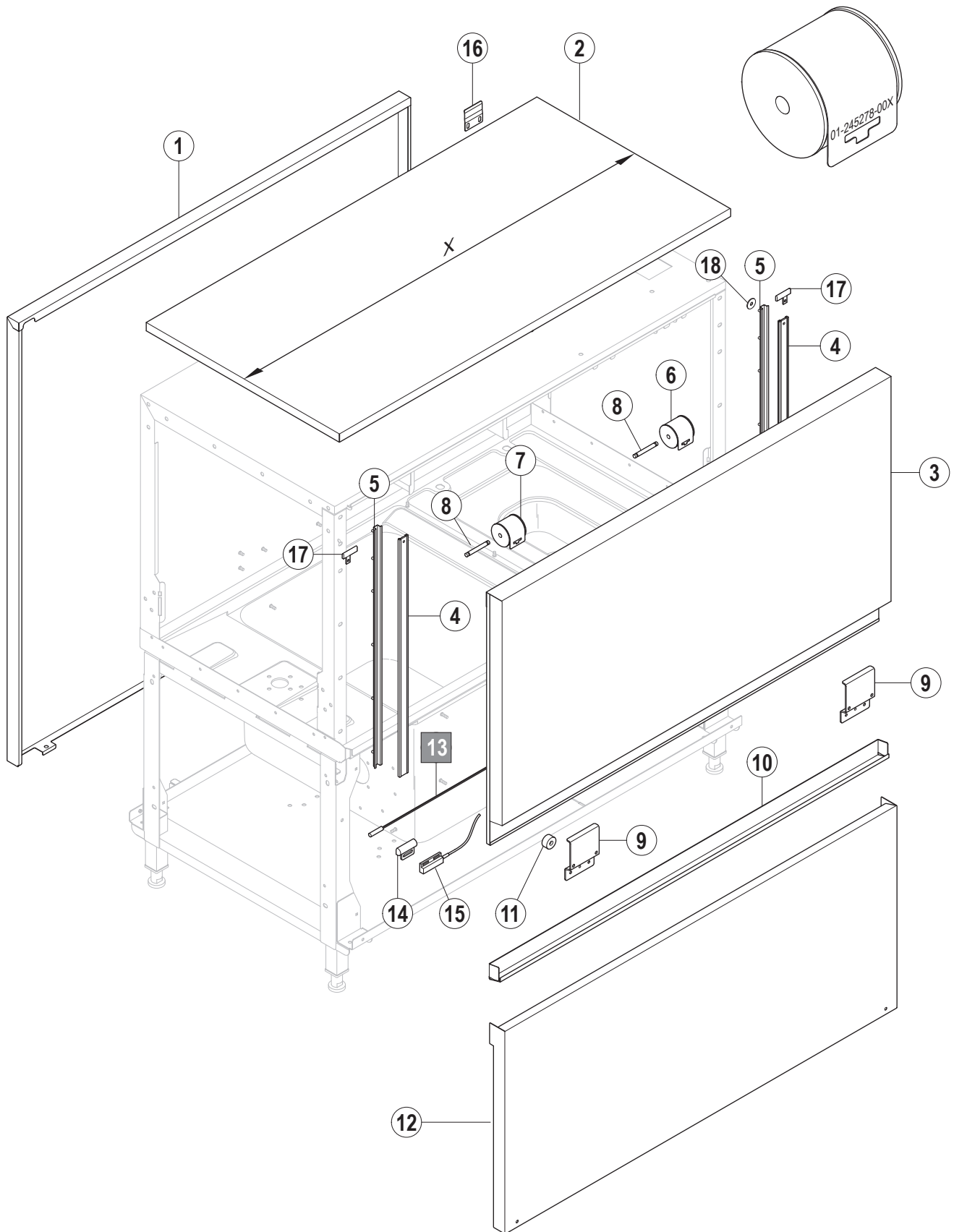

17.1

CN 17.1a

Pos.	A	B			X [mm]	Bemerkung / Remarks / Remarques
		CS	CN	CP		
01		01-291317-005	01-291317-001	---	1350	ohne Isolierung / without insulation / sans isolation
		---	01-291317-002	---	900	ohne Isolierung / without insulation / sans isolation
		---	01-291317-003	---	650	ohne Isolierung / without insulation / sans isolation
		01-291317-006	01-291317-004	---	500	ohne Isolierung / without insulation / sans isolation
		---	01-291317-008	=	300	ohne Isolierung / without insulation / sans isolation
		---	01-291711-001	=	1350	mit Isolierung / with insulation / avec isolation
		---	01-291711-002	=	900	mit Isolierung / with insulation / avec isolation
		---	01-291711-003	=	650	mit Isolierung / with insulation / avec isolation
02		01-291397-010	01-291397-001	---	850	ohne Isolierung / without insulation / sans isolation
		01-291397-002	=	---	900	ohne Isolierung / without insulation / sans isolation
		---	01-291397-003	---	650	ohne Isolierung / without insulation / sans isolation
		01-291397-004	=	---	500	ohne Isolierung / without insulation / sans isolation / E-Modul
		---	01-291397-008	---	500	ohne Isolierung / without insulation / sans isolation / Demi-Modul
		---	01-291397-005	---	450	ohne Isolierung / without insulation / sans isolation
		01-291397-006	=	---	1350	ohne Isolierung / without insulation / sans isolation
		---	01-291397-007	---	300	ohne Isolierung / without insulation / sans isolation
		---	01-291398-001	=	850	mit Isolierung / with insulation / avec isolation
		---	01-291398-002	=	900	mit Isolierung / with insulation / avec isolation
		---	01-291398-003	=	650	mit Isolierung / with insulation / avec isolation
		---	01-291398-004	=	500	mit Isolierung / with insulation / avec isolation / E-Modul
		---	01-291398-008	=	500	mit Isolierung / with insulation / avec isolation / Demi-Modul
		---	01-291398-005	=	450	mit Isolierung / with insulation / avec isolation
03		01-291320-005	---	---	1350	ohne Isolierung / without insulation / sans isolation
		01-291321-001	=	=	1350	mit Isolierung / with insulation / avec isolation
		---	01-291321-002	=	900	mit Isolierung / with insulation / avec isolation
		---	01-291321-003	=	650	mit Isolierung / with insulation / avec isolation
		---	01-291321-004	=	500	mit Isolierung / with insulation / avec isolation
04		00-325064-008	=	=		
05		01-245126-003	=	=		
06		01-245278-004	---	---	1350	Tür ohne Isolierung / door without insulation / porte sans isolation
		01-245278-007	=	=	1350	Tür mit Isolierung / door with insulation / porte avec isolation
		---	01-245278-005	=	900	Tür mit Isolierung / door with insulation / porte avec isolation
		---	01-245278-003	=	650	Tür mit Isolierung / door with insulation / porte avec isolation
		---	01-245278-002	=	500	Tür mit Isolierung / door with insulation / porte avec isolation
07		01-245278-003	---	---	1350	Tür ohne Isolierung / door without insulation / porte sans isolation
		01-245278-006	=	=	1350	Tür mit Isolierung / door with insulation / porte avec isolation
		---	01-245278-005	=	900	Tür mit Isolierung / door with insulation / porte avec isolation
		---	01-245278-003	=	650	Tür mit Isolierung / door with insulation / porte avec isolation
		---	01-245278-002	=	500	Tür mit Isolierung / door with insulation / porte avec isolation
08		01-245281-001	=	=		
09		01-245127-001	=	=	1350	
		---	01-245127-001	=	900	
		---	01-245127-003	=	650	
		---	01-245279-001	=	500	

Pos.	A	B			X [mm]	Bemerkung / Remarks / Remarques
		CS	CN	CP		
10		01-245129-005	=	=	1350	
		---	01-245129-002		900	
		---	01-245129-006		650	
		---	01-245129-004		500	
11		00-774714-001	=	=		
12	L/R	01-291787-001	---	---	1350	
	R/L	01-291787-002	---	---	1350	
		---	01-291787-004	----	1350	ohne Vorwaschung / without prewash / sans pré lavage
	L/R	---	01-291787-005	01-291407-010	1350	mit Vorwaschung / with prewash / avec pré lavage
	R/L	---	01-291787-006	01-291407-010	1350	mit Vorwaschung / with prewash / avec pré lavage
	L/R	---	01-291407-004	=	900	S- Modul
	R/L	---	01-291407-005	=	900	S- Modul
		---	01-291407-011	=	900	A- Modul
	L/R	---	01-291407-006		650	L-Modul
	R/L	---	01-291407-007		650	L-Modul
		---	01-291407-008		650	Spülmodul / rinse module / module de rinçage
	L/R	---	01-291407-009	---	500	Demi-Modul / Demi module / Demi module
	R/L	---	01-291407-015	---	500	Demi-Modul / Demi module / Demi module
			---	01-291407-016	---	500
13		---	01-240288-001	---		
14		---	00-883838-001	---		
15		00-229517-000	---	---		
16		01-291605-001	=	=		
17		01-291426-001	=	=		
18		00-696936-066	=	=		

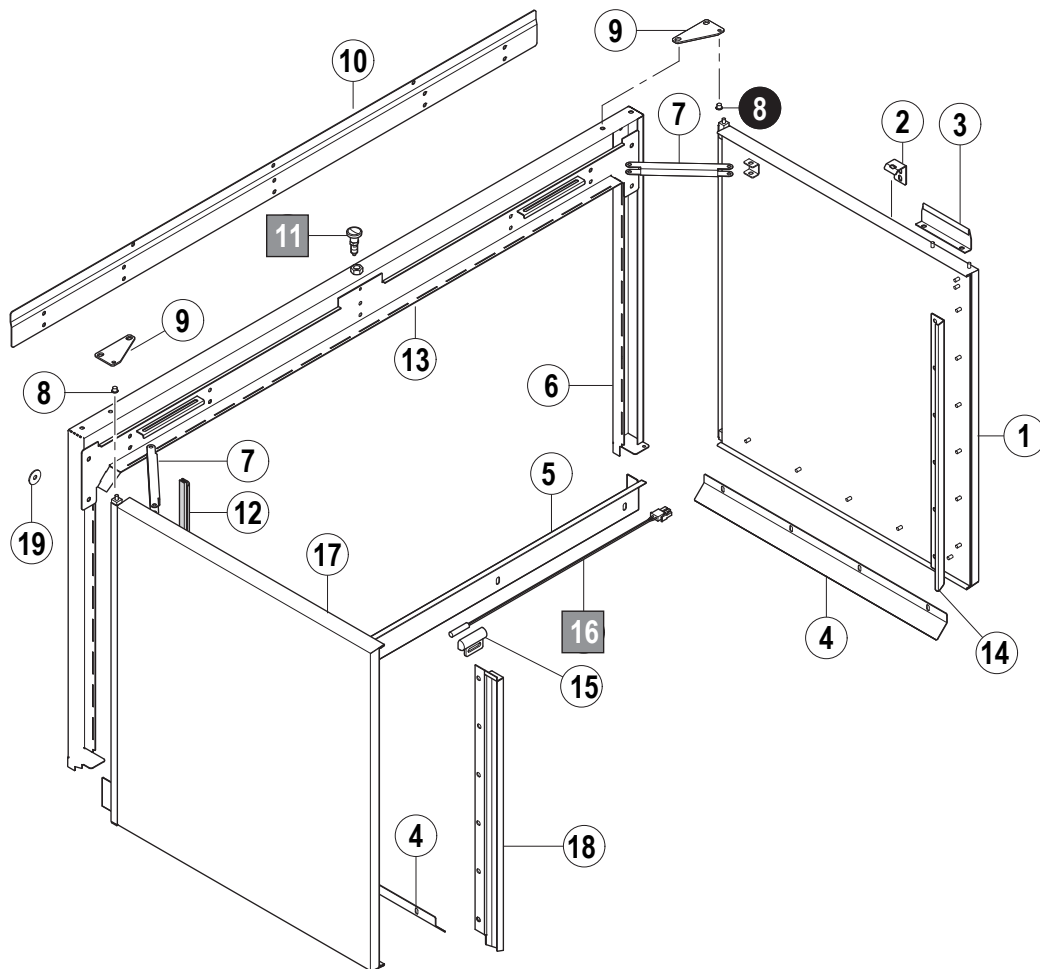
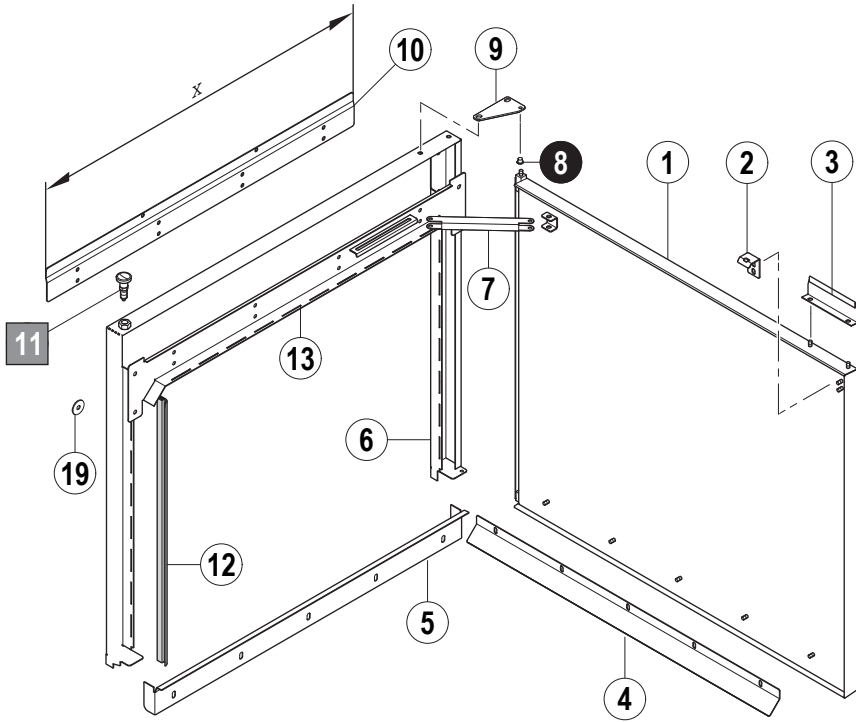

17.2

Pos.	A	B			X [mm]	Bemerkung / Remarks / Remarques
		CS	CN	CP		
01		01-245985-011	=	=	500	
		01-245985-012	=	=	650	
		01-245985-013	=	=	900	
		01-245985-014	=	=	1350	
02		01-247015-002	=	=		
03		00-896817-002	=	=		
04		01-243888-001	=	=	500	
		01-243888-002	=	=	650	
		01-243888-004	=	=	900	
		01-243888-014	=	=	1350	
05		01-245988-003	=	=	500	
		01-245988-002	=	=	650	
		01-245988-001	=	=	900	
		01-245988-006	=	=	1350	
06		01-291979-003	=	=	500	
		01-291979-002	=	=	650	
		01-291979-001	=	=	900	
		01-291979-004	=	=	1350	
07		01-245990-001	=	=		
08		00-298963-014	=	=		
09		00-784243-001	=	=		
10		01-291062-003	=	=	500	
		01-291062-002	=	=	650	
		01-291062-001	=	=	900	
		01-291062-006	=	=	1350	
11		01-247013-001	=	=		
12		01-243873-015	=	=		L=1700 mm
		01-243873-017	=	=		L=2100 mm
		01-243873-021	=	=		L=2600 mm
13		01-245987-003	=	=	500	
		01-245987-002	=	=	650	
		01-245987-001	=	=	900	
		01-245987-006	=	=	1350	
14		01-245996-004	=	=		
15		---	01-240288-001	=		
16		---	00-883838-001	=		
17		01-245985-015	=	=		
18		01-291111-004	=	=		
19		00-696936-066	=	=		

CS / CN / CP

Trocknung – gerade

Dryer – straight

Séchage – droit

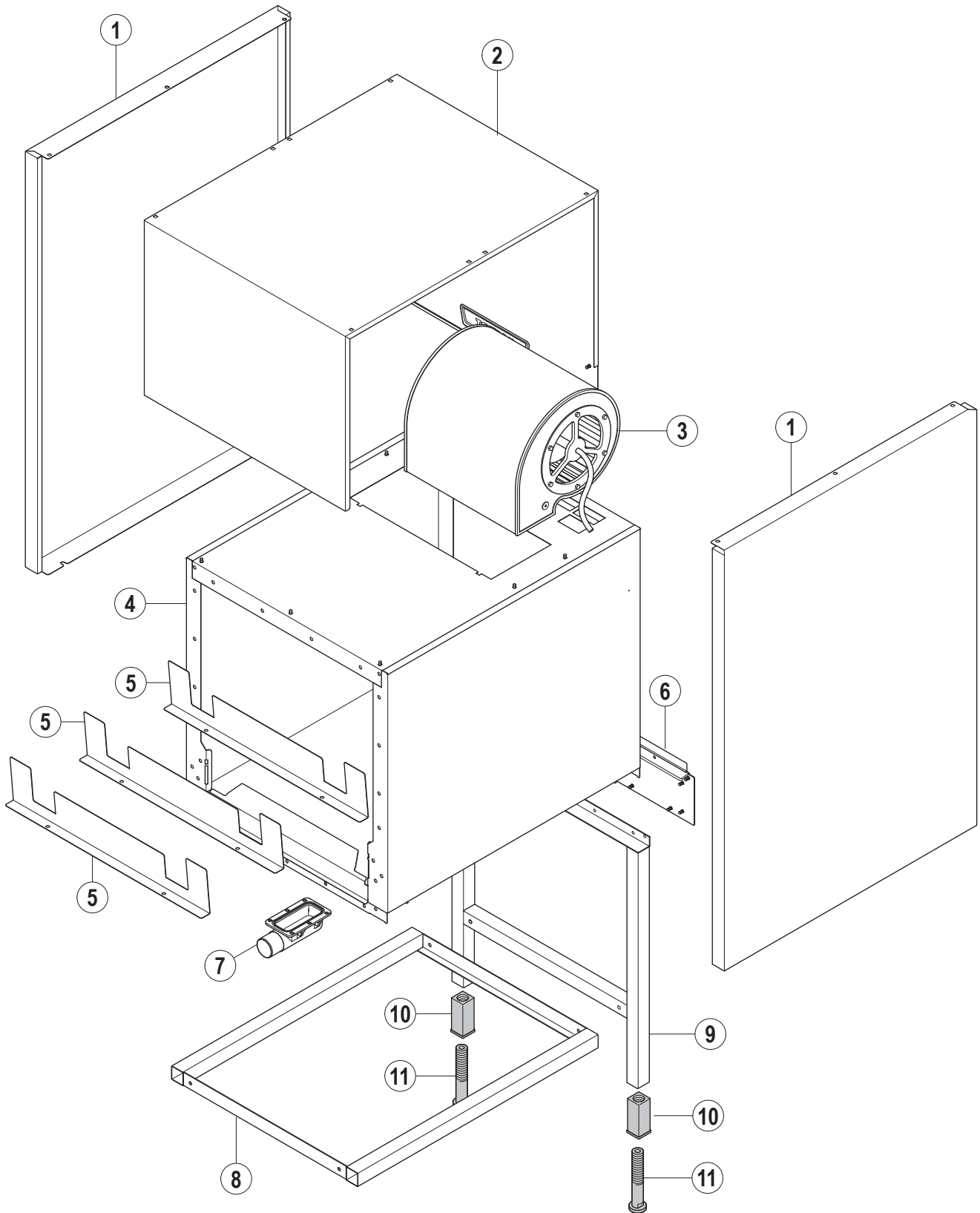

18.1

CN 18.1

Pos.	A	B			X [mm]	Bemerkung / Remarks / Remarques
		CS	CN	CP		
01		01-291462-002	01-291462-001	---		ohne Isolierung / without insulation / sans isolation
		01-291828-002	01-291828-001	---		mit Isolierung / with insulation / avec isolation
02		01-291453-002	01-291453-001	---		
03		00-897700-...	=	---		siehe Schaltplan / see wiring diagram / voir schéma de câblage
04		01-291451-004	01-291451-001	---		
05		01-291713-001	=	---		
06		01-291429-002	=	---		
07		00-325529-001	=	---		
08		00-378747-377	00-378747-186	---		
09		00-734997-001	=	---		
10		00-325008-001	=	---		
11		00-325007-001	=	---		

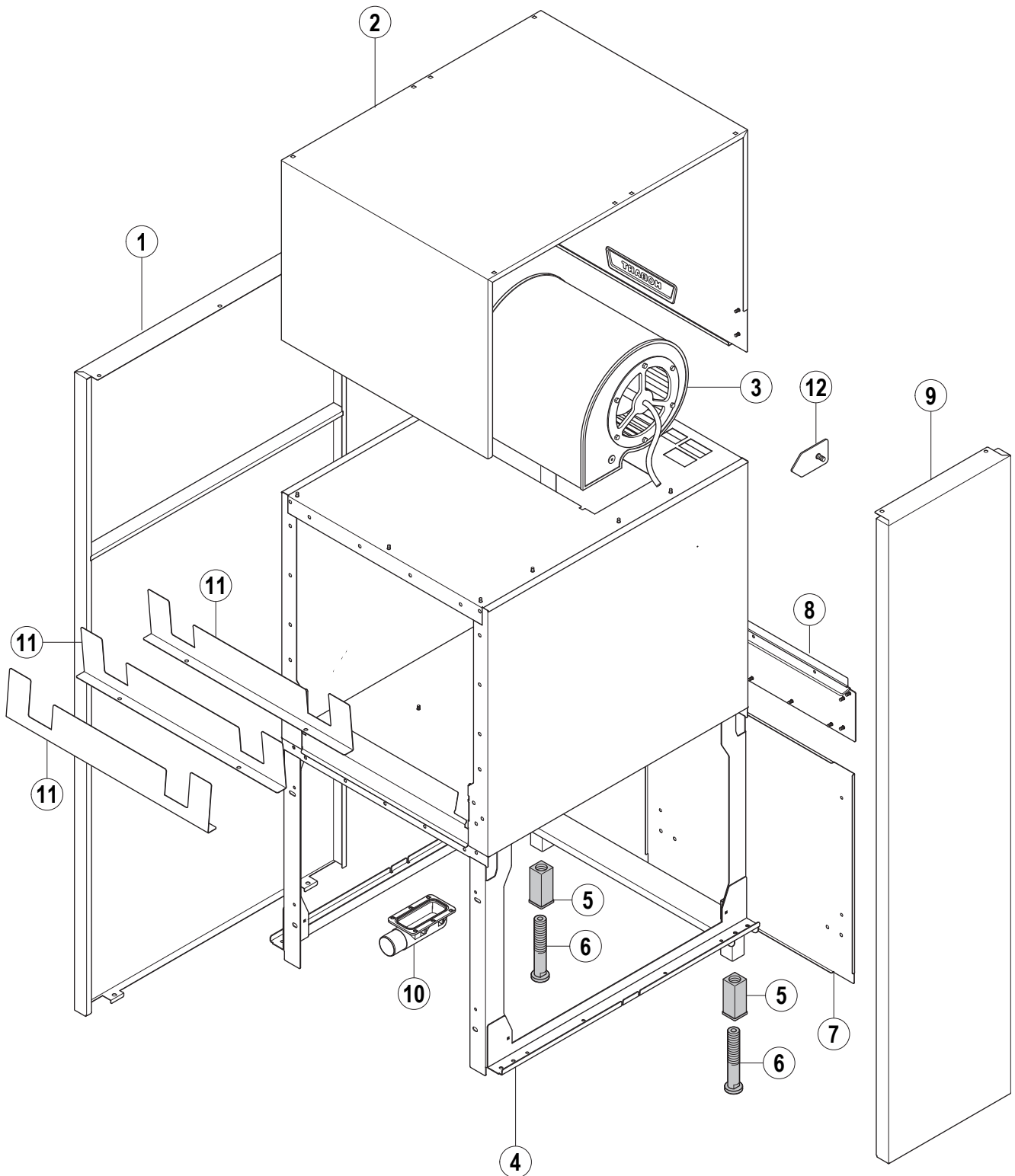

Pos.	A	B			X [mm]	Bemerkung / Remarks / Remarques
		CS	CN	CP		
01		---	01-291467-001	=		ohne Isolierung / without insulation / sans isolation
		---	01-291829-001	=		mit Isolierung / with insulation / avec isolation
02		---	01-291453-001	=		
03		---	00-897700-...	=		siehe Schaltplan / see wiring diagram / voir schéma de câblage
04		---	01-291518-001	=		
05		---	00-325008-001	=		
06		---	00-325007-001	=		
07		---	01-291419-003	=		
08		---	01-291429-002	=		
09		---	01-291467-002	=		ohne Isolierung / without insulation / sans isolation
		---	01-291829-002	=		mit Isolierung / with insulation / avec isolation
10		---	00-325529-001	=		
11		---	01-291713-001	=		
12		---	01-296621-001	=		

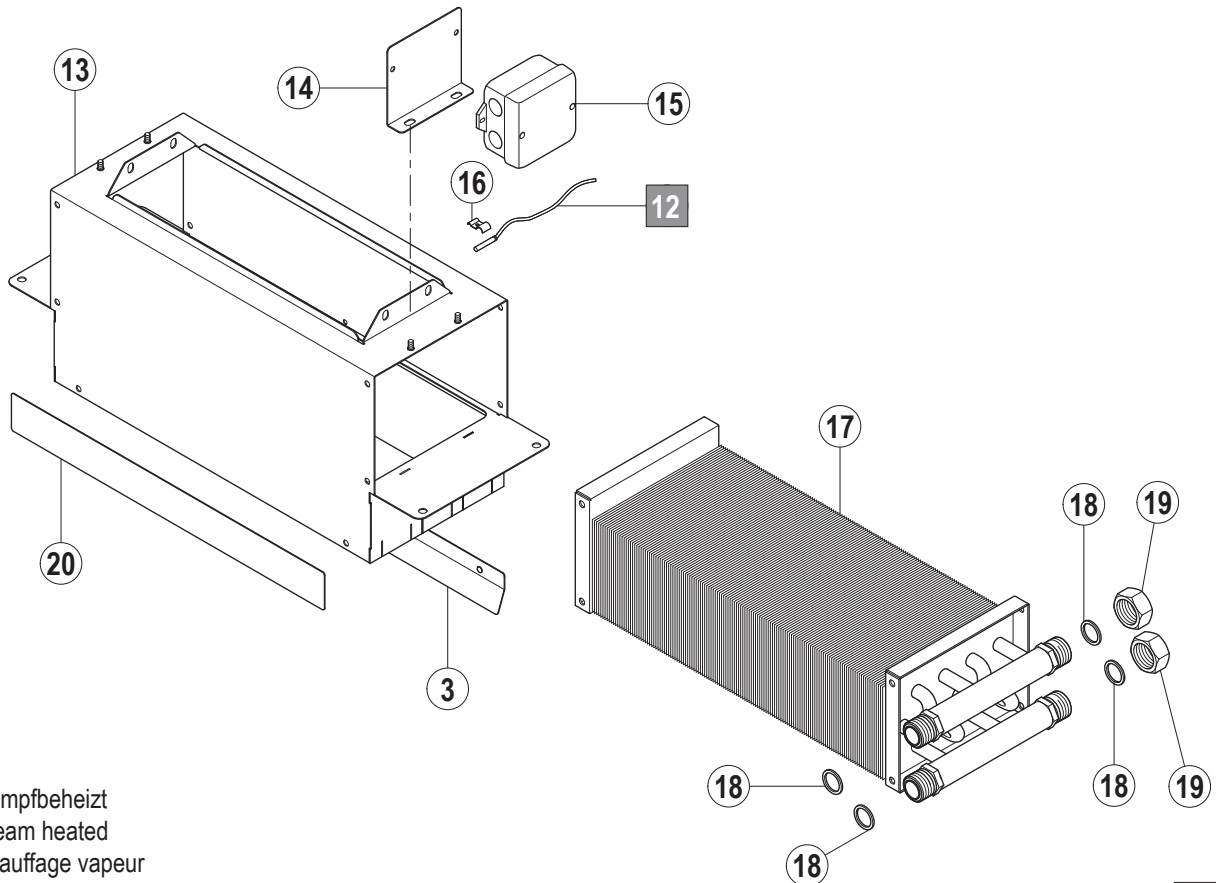
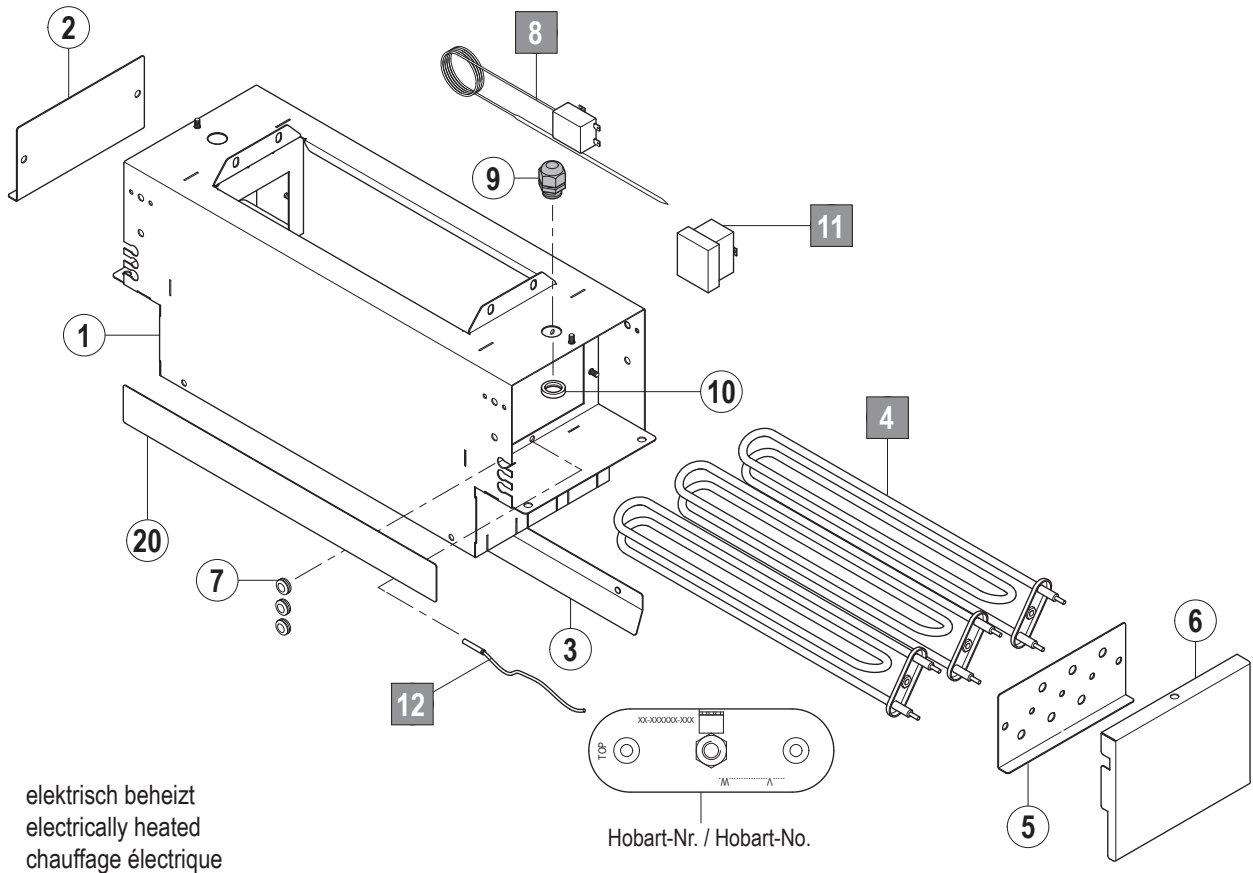

18.3

Pos.	A	B			X [mm]	Bemerkung / Remarks / Remarques
		CS	CN	CP		
01		01-291465-001	=	=		
02		01-245214-004	=	=		
03		01-245557-005	=	=		
04		00-229189-...	=	=		Nr. siehe Flansch / no. see flange / no. voir bride
05		01-245554-002	=	=		
06		01-291463-001	=	=		
07		00-227748-001	=	=		
08		00-226505-001	---	---		
09		00-695661-003	=	=		
10		00-695665-003	=	=		
11		00-378791-000	=	=		
12		---	00-775612-001	=		
13		---	01-291894-001	=		
14		---	01-291974-001	=		
15		---	00-232633-000	=		
16		---	00-324157-000	=		
17		---	01-291895-001	=		
18		---	00-302574-014	=		
19		---	01-245605-001	=		
20		---	01-296197-001	=		nur CDC / only CDC / seulement CDC

CS / CN / CP
Transportkurven
Transport curves
Convoyage d'angle

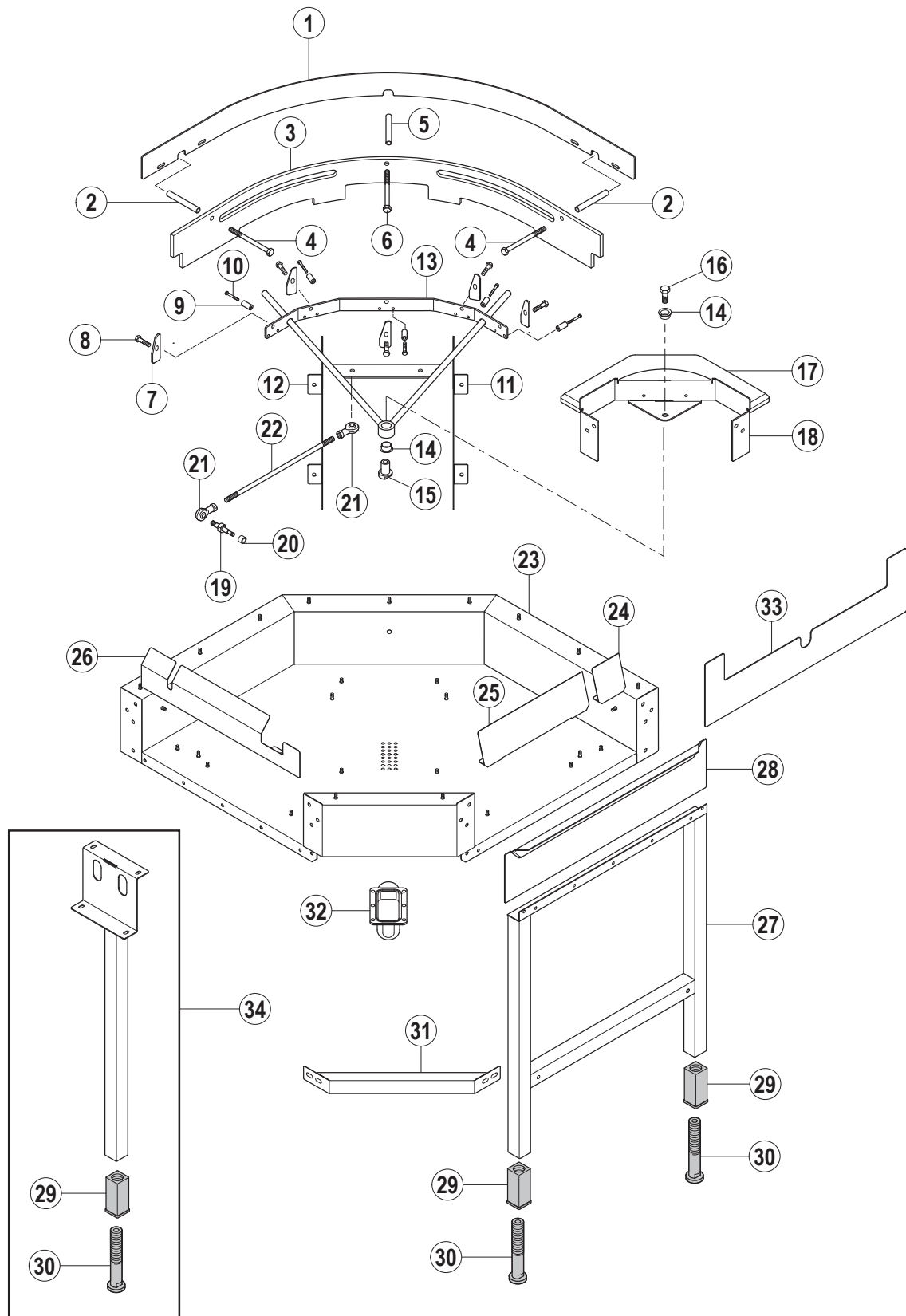

19.1

CN 19.1

Pos.	A	B			X [mm]	Bemerkung / Remarks / Remarques
		CS	CN	CP		
01		00-896433-001	=	=		
02		00-866524-003	=	=		
03		00-896431-001	=	=		
04		00-603124-000	=	=		
05		00-866524-002	=	=		
06		00-604059-000	=	=		
07		00-897777-001	=	=		
08		00-609312-000	=	=		
09		00-380528-037	=	=		
10		00-602643-000	=	=		
11		00-897727-001	=	=		
12		00-897727-002	=	=		
13		00-896440-001	=	=		
14		00-298963-012	=	=		
15		00-734988-001	=	=		
16		00-602594-000	=	=		
17		00-897769-001	=	=		
18		01-291724-001	=	=		
19		00-884105-001	=	=		
20		01-243284-002	=	=		
21		00-609067-000	=	=		
22		00-884128-009	=	=		L=360 mm
		00-884128-010	=	=		L=480 mm
23		01-291719-001	=	=		ohne Trocknung / without dryer / sans séchage
		01-291719-002	=	=		mit Trocknung / with dryer / avec séchage
24		00-897738-002	=	=		
25		00-897738-001	=	=		
26	L/R	01-242184-001	=	=		
	R/L	01-242184-002	=	=		
27		00-734997-001	=	=		
28		01-291429-002	=	=		
29		00-325008-001	=	=		
30		00-325007-001	=	=		
31		00-899284-001	=	=		
32		00-325529-001	=	=		
33		01-291759-001	=	=		
34		00-896438-001	=	=		

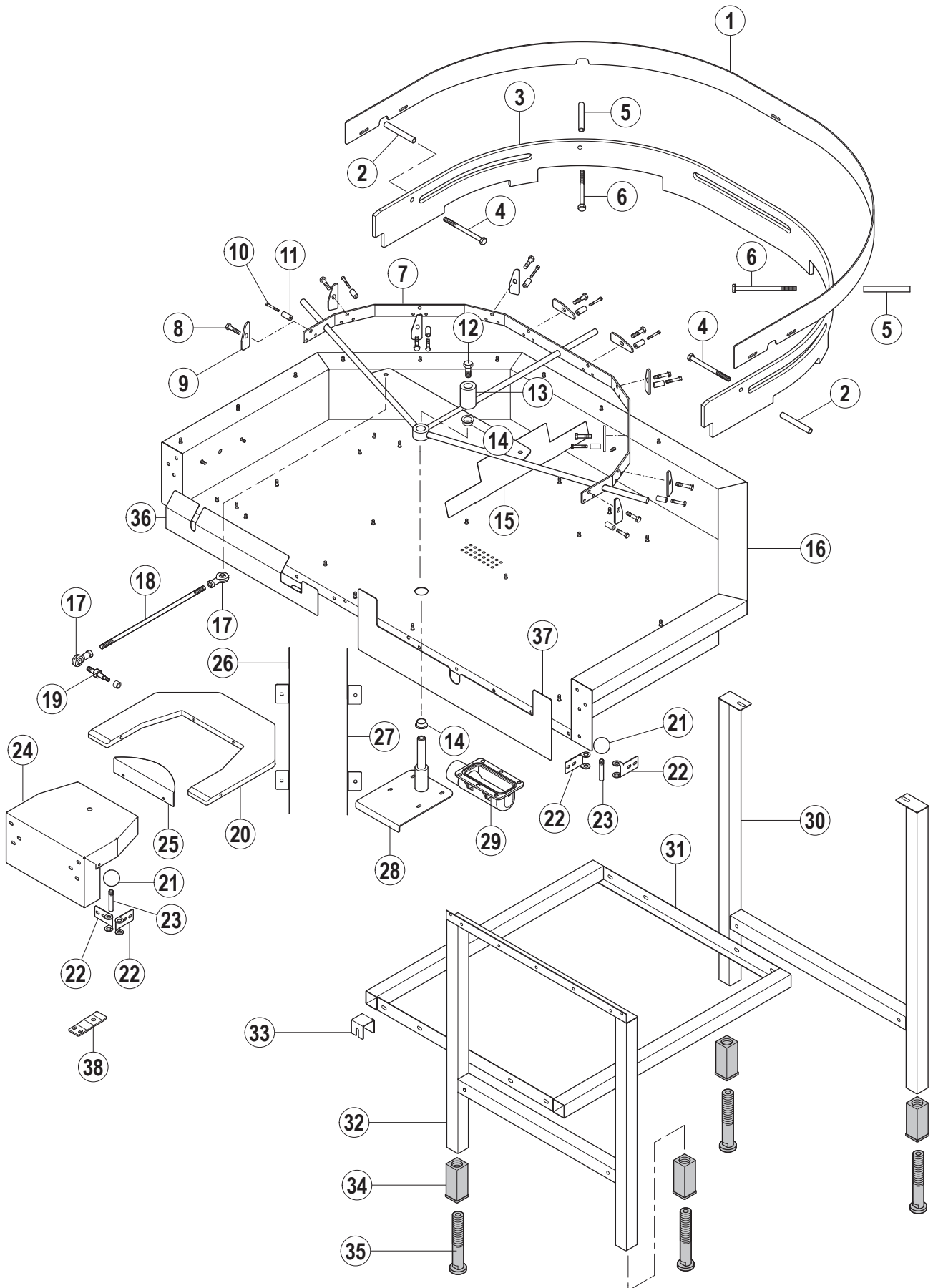

Pos.	A	B			X [mm]	Bemerkung / Remarks / Remarques
		CS	CN	CP		
01		01-245225-001	=	=		
02		00-866524-003	=	=		
03		01-243213-001	=	=		
04		00-603124-000	=	=		
05		00-866524-002	=	=		
06		00-604-059-000	=	=		
07		01-243216-001	=	=		
08		00-609312-000	=	=		
09		00-897777-001	=	=		
10		00-602573-000	=	=		
11		00-380528-037	=	=		
12		00-602594-000	=	=		
13		01-243217-001	=	=		
14		00-298963-012	=	=		
15		01-243234-001	=	=		
16	L/R	01-291762-001	=	=		ohne Trocknung / without dryer / sans séchage
	R/L	01-291762-002	=	=		ohne Trocknung / without dryer / sans séchage
	L/R	01-291762-003	=	=		mit Trocknung / with dryer / avec séchage
	R/L	01-291762-004	=	=		mit Trocknung / with dryer / avec séchage
17		00-609067-000	=	=		
18		00-884128-009	=	=		L=360 mm
19		00-884105-001	=	=		
20		01-243214-001	=	=		
21		00-603618-000	=	=		
22		01-243233-001	=	=		
23		00-735094-001	=	=		
24		01-291763-001	=	=		
25		01-243229-001	=	=		
26		00-897727-002	=	=		
27		00-897727-001	=	=		
28		01-243220-001	=	=		
29		00-325529-001	=	=		
30		00-896477-001	=	=		
31		01-243230-001	=	=		
32		00-734997-001	=	=		
33		00-895610-001	=	=		
34		00-325008-001	=	=		
35		00-325007-001	=	=		
36	L/R	01-242184-001	=	=		
	R/L	01-242184-002	=	=		
37		01-291759-001	=	=		
38		01-296169-001	=	=		nur bei CDC-C/CTC-C an ND-Modul / only with CDC-C/CTC-C in ND-module / seulement à CDC-C/CTC-C au module ND

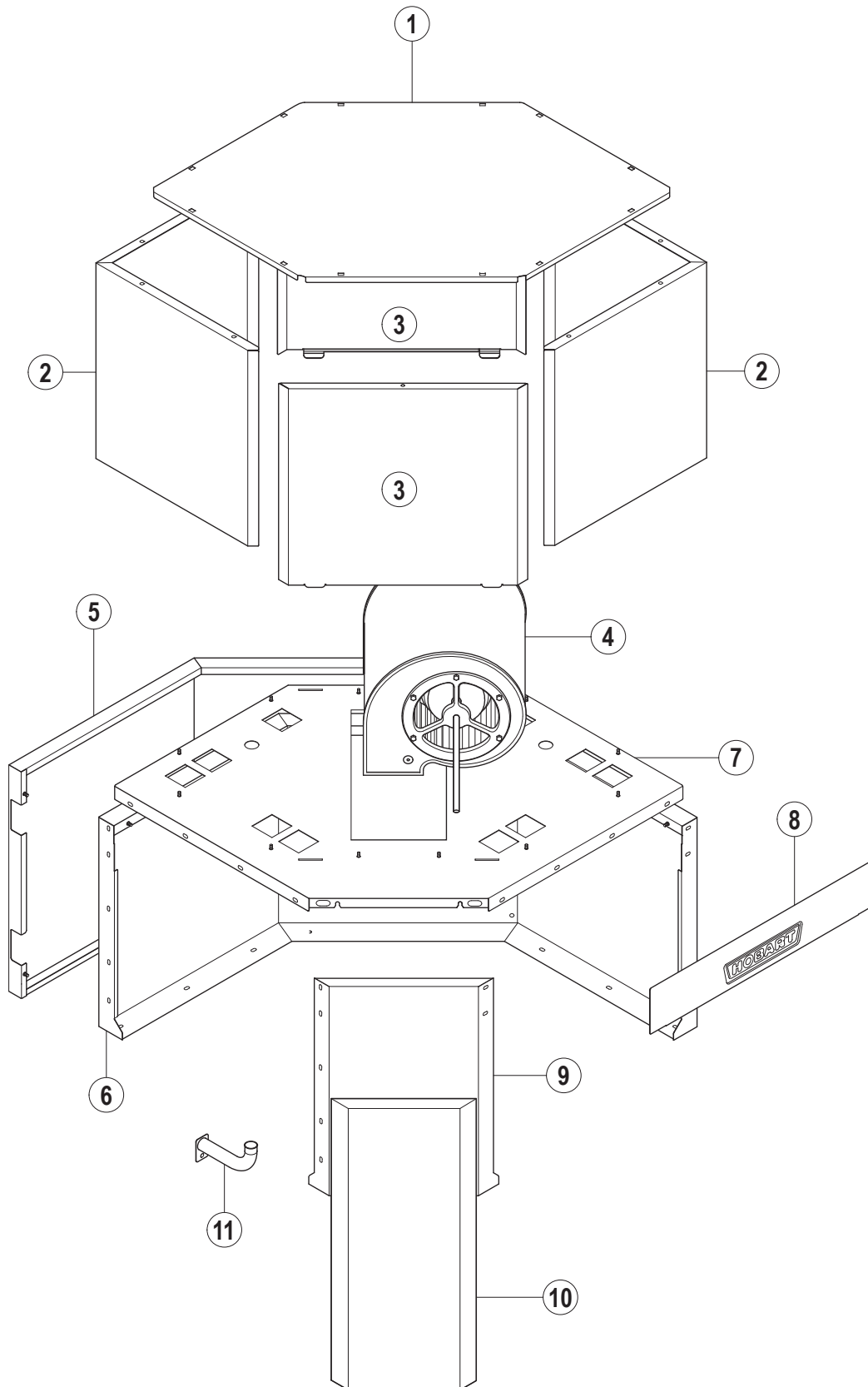

Pos.	A	B			X [mm]	Bemerkung / Remarks / Remarques
		CS	CN	CP		
01		01-291734-001	=	=		
02		01-291732-001	=	=		
03		01-291735-001	=	=		
04		00-897700-...	=	=		siehe Schaltplan / see wiring diagram / voir schéma de câblage
05		01-291737-001	=	=		
06	L/R	01-291726-001	=	=		
	R/L	01-291726-002	=	=		
07		01-291728-001	=	=		
08		01-291497-002	=	=		
09	L/R	01-291731-001	=	=		CDC91
	R/L	01-291731-002	=	=		CDC91
	L/R	01-291765-001	=	=		CDC181-C
	R/L	01-291765-002	=	=		CDC181-C
10		01-291756-001	=	=		CDC91
		01-291841-001	=	=		CDC181-C
11		01-291754-001	=	=		

CS / CN / CP
Dampfverrohrung
Steam piping
Tuyauterie vapeur

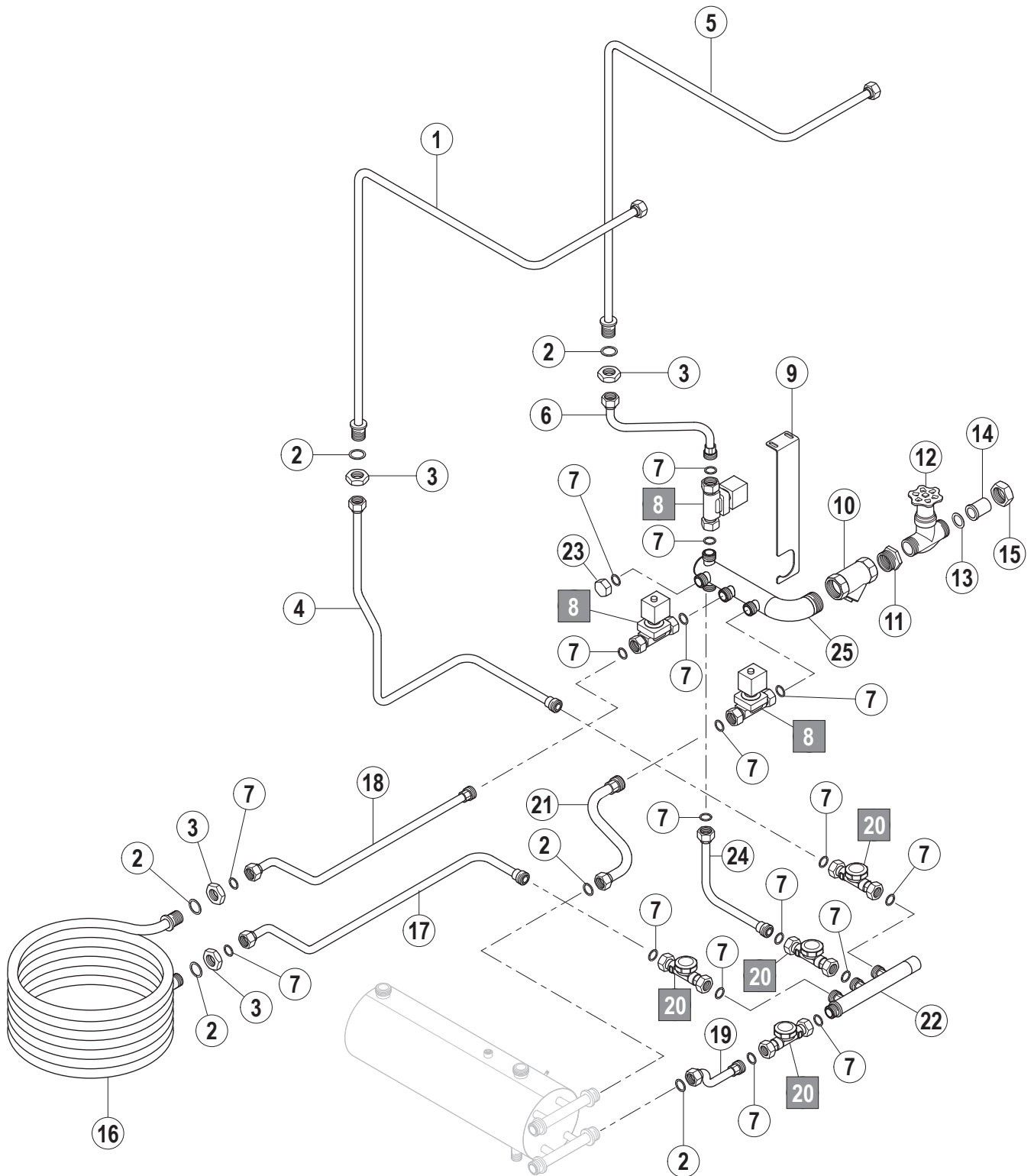

Pos.	A	B			X [mm]	Bemerkung / Remarks / Remarques
		CS	CN	CP		
01	L/R	---	01-291891-001	---		mit CDS-Trockung / with CDS dryer / avec séchage CDS
	R/L	---	01-291891-003	---		mit CDS-Trockung / with CDS dryer / avec séchage CDS
	L/R	---	01-291897-001	---		mit CDC-Trockung / with CDC dryer / avec séchage CDC
	R/L	---	01-291897-003	---		mit CDC-Trockung / with CDC dryer / avec séchage CDC
02		---	00-304084-010	---		
03		---	00-609698-000	---		
04	L/R	---	01-291919-001	---		mit CDS-Trockung / with CDS dryer / avec séchage CDS
	R/L	---	01-291932-001	---		mit CDS-Trockung / with CDS dryer / avec séchage CDS
	L/R	---	01-291919-002	---		mit CDC-Trockung / with CDC dryer / avec séchage CDC
	R/L	---	01-291932-002	---		mit CDC-Trockung / with CDC dryer / avec séchage CDC
05	L/R	---	01-291891-002	---		mit CDS-Trockung / with CDS dryer / avec séchage CDS
	R/L	---	01-291891-004	---		mit CDS-Trockung / with CDS dryer / avec séchage CDS
	L/R	---	01-291897-002	---		mit CDC-Trockung / with CDC dryer / avec séchage CDC
	R/L	---	01-291897-004	---		mit CDC-Trockung / with CDC dryer / avec séchage CDC
06		---	01-2919907-001	---		mit CDS-Trockung / with CDS dryer / avec séchage CDS
		---	01-2919907-002	---		mit CDC-Trockung / with CDC dryer / avec séchage CDC
07		---	00-302574-014	---		
08		---	01-245593-001	---		Dampf / steam / vapeur 1 - 3,5 bar
		---	01-245593-002	---		Dampf / steam / vapeur <= 1 bar
09		---	01-291929-001	---		
10		---	00-774429-001	---		
11		---	00-609276-000	---		
12		---	00-165829-102	---		
13		---	00-300084-007	---		
14		---	00-846944-002	---		
15		---	00-609460-000	---		
16		---	01-245647-002	---		
17	L/R	---	01-291917-001	---		
	R/L	---	01-291917-002	---		
18		---	01-291905-001	---		
19		---	01-291915-001	---		
20		---	01-245603-002	---		
21		---	01-291899-001	---		
22		---	01-291912-001	---		
23		---	01-245605-001	---		
24		---	01-291909-001	---		
25		---	01-291902-001	---		

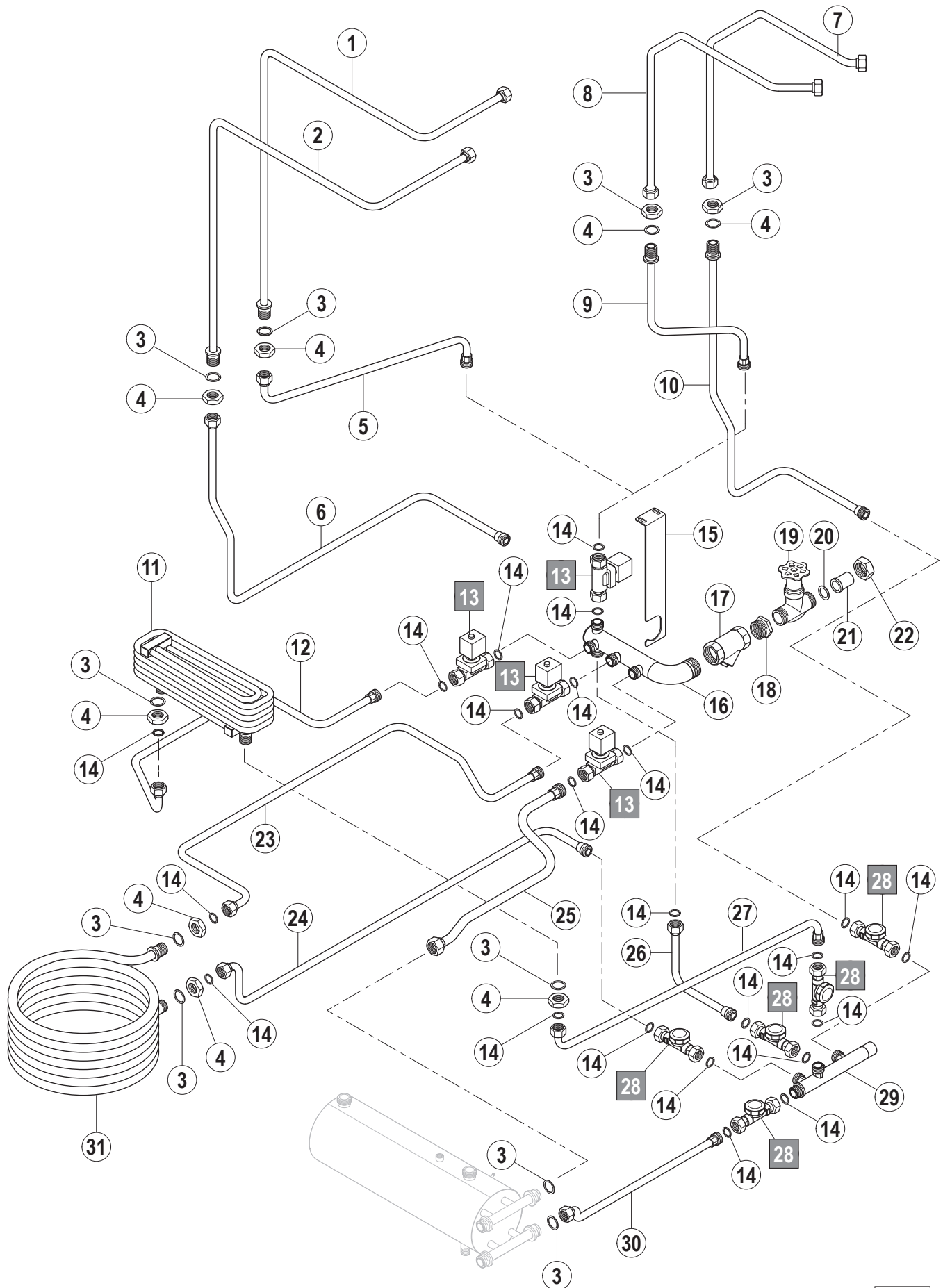

Pos.	A	B			X [mm]	Bemerkung / Remarks / Remarques
		CS	CN	CP		
01	L/R	---	01-291891-001	=		mit DS-Trockung / with DS dryer / avec séchage DS
	R/L	---	01-291891-003	=		mit DS-Trockung / with DS dryer / avec séchage DS
02	L/R	---	01-291891-002	=		mit DS-Trockung / with DS dryer / avec séchage DS
	R/L	---	01-291891-004	=		mit DS-Trockung / with DS dryer / avec séchage DS
03		---	00-304084-010	=		
04		---	00-609698-000	=		
05		---	01-291907-003	=		
06	L/R	---	01-291919-004	=		
	R/L	---	01-291932-004	=		
07	L/R	---	01-291897-001	=		mit CDC-Trockung / with CDC dryer / avec séchage CDC
	R/L	---	01-291897-003	=		mit CDC-Trockung / with CDC dryer / avec séchage CDC
08	L/R	---	01-291897-002	=		mit CDC-Trockung / with CDC dryer / avec séchage CDC
	R/L	---	01-291897-004	=		mit CDC-Trockung / with CDC dryer / avec séchage CDC
09		---	01-291907-004	=		
10	L/R	---	01-291919-003	=		
	R/L	---	01-291932-003	=		
11		---	---	01-291055-001		
12	L/R	---	---	01-291934-001		
	R/L	---	---	01-291934-002		
13		---	01-245593-001	=		Dampf / steam / vapeur 1 - 3,5 bar
		---	01-245593-002	=		Dampf / steam / vapeur <= 1 bar
14		---	00-302574-014	=		
15		---	01-291929-001	=		
16		---	01-291902-001	=		
17		---	00-774429-001	=		
18		---	00-609276-000	=		
19		---	00-165829-102	=		
20		---	00-300084-007	=		
21		---	00-846944-002	=		
22		---	00-609460-000	=		
23	L/R	---	01-291936-001	=		
	R/L	---	01-291936-002	=		
24	L/R	---	01-291917-003	=		
	R/L	---	01-291917-004	=		
25		---	01-291899-002	=		
26		---	01-291909-001	=		
27		---	---	01-291922-001		
28		---	01-245603-002	=		
29		---	01-291912-001	=		A-Maschine / A- machine
		---	01-291912-004	=		AA-Maschine / AA- machine
	L/R	---	---	01-291912-002		
	R/L	---	---	01-291912-003		
30		---	01-291915-002	=		
31		---	01-245647-002	=		

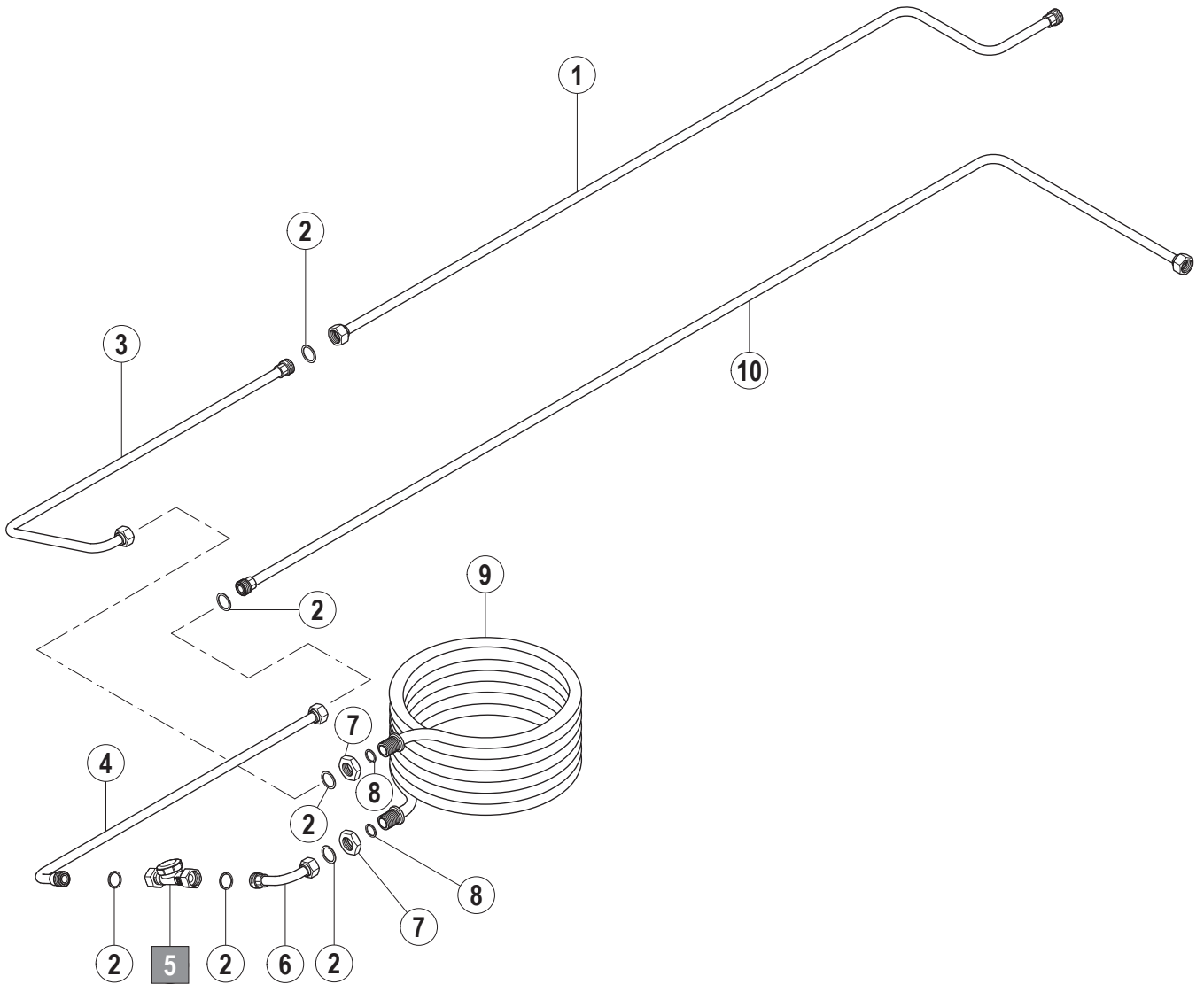

Pos.	A	B			X [mm]	Bemerkung / Remarks / Remarques
		CS	CN	CP		
01		---	01-291926-001	---		
02		---	00-302574-014	---		
03		---	01-291926-002	---		
04		---	01-291924-002	---		
05		---	01-245603-002	---		
06		---	01-291924-003	---		
07		---	00-609698-000	---		
08		---	00-300084-010	---		
09		---	01-245647-002	---		
10		---	01-291924-001	---		

CS / CN / CP

CAF Eckeinschub

CAF corner guiding

CAF guidage sur angle

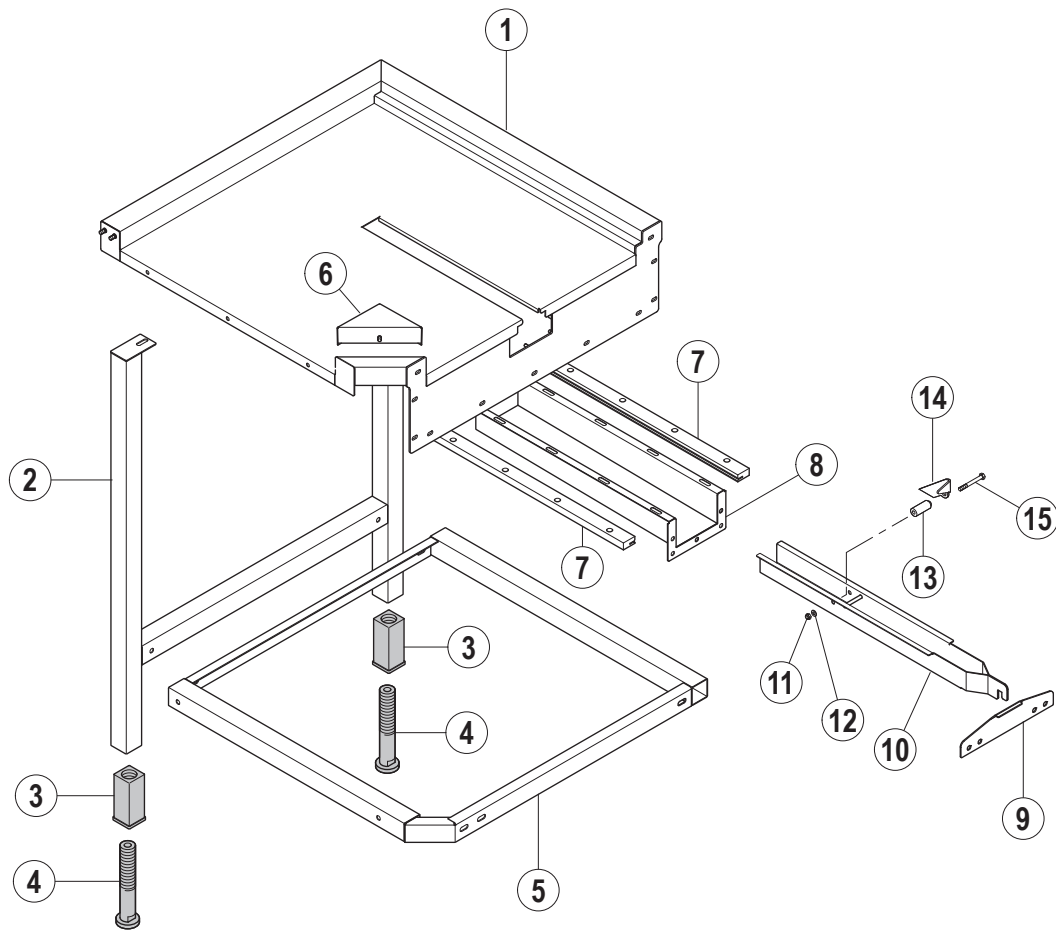



A Laufrichtung
Working direction
Sens de marche

B Maschinen-Grundtyp
Basic machine
Machine de base

X Länge
Length
Longueur

Pos.	A	B			X [mm]	Bemerkung / Remarks / Remarques
		CS	CN	CP		
01	L/R	01-296079-001	=	=		
	R/L	01-296082-001	=	=		
02		00-896477-001	=	=		
03		00-325008-001	=	=		
04		00-325007-001	=	=		
05	L/R	00-896478-001	=	=		
	R/L	00-896478-002	=	=		
06		00-896362-001	=	=		
07		00-734945-001	=	=		
08		00-734947-001	=	=		
09		01-296076-001	=	=		
10		01-296078-001	=	=		
11		00-602502-000	=	=		
12		00-602286-000	=	=		
13		01-249194-001	=	=		
14	L/R	01-249191-001	=	=		
	R/L	01-249191-002	=	=		
15		00-603355-000	=	=		

CS / CN / CP

Tischenschalter

Table end switch

**Interrupteur fin-de-course
de table**

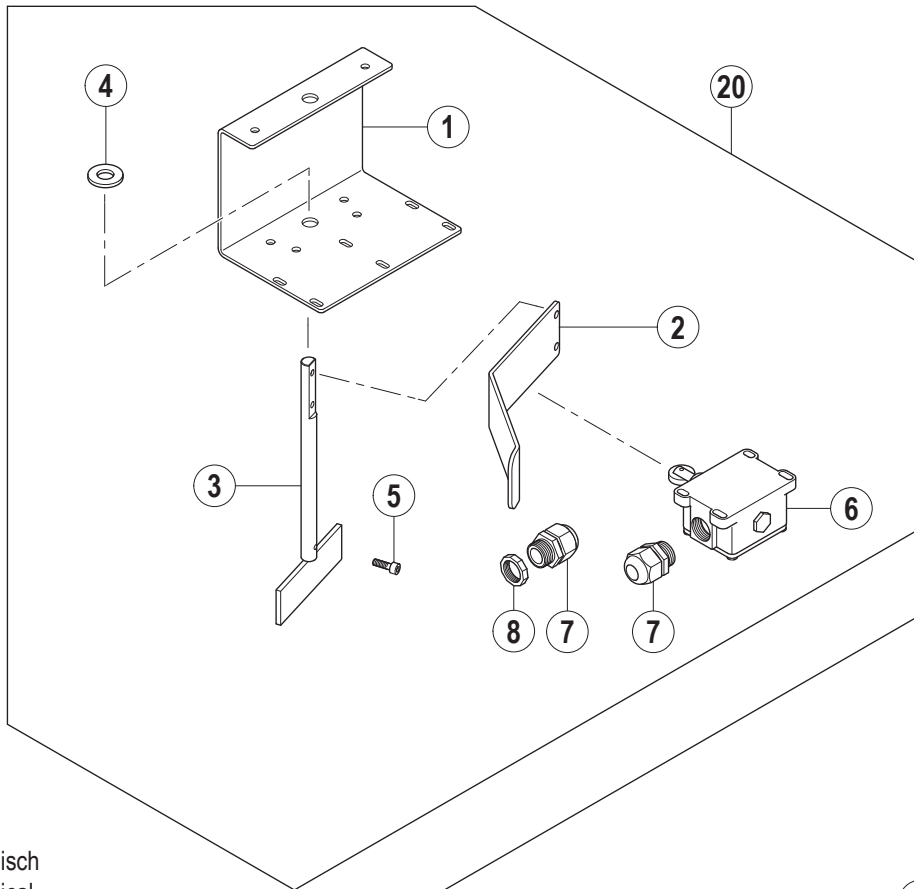

mechanisch
 mechanical
 mécanique

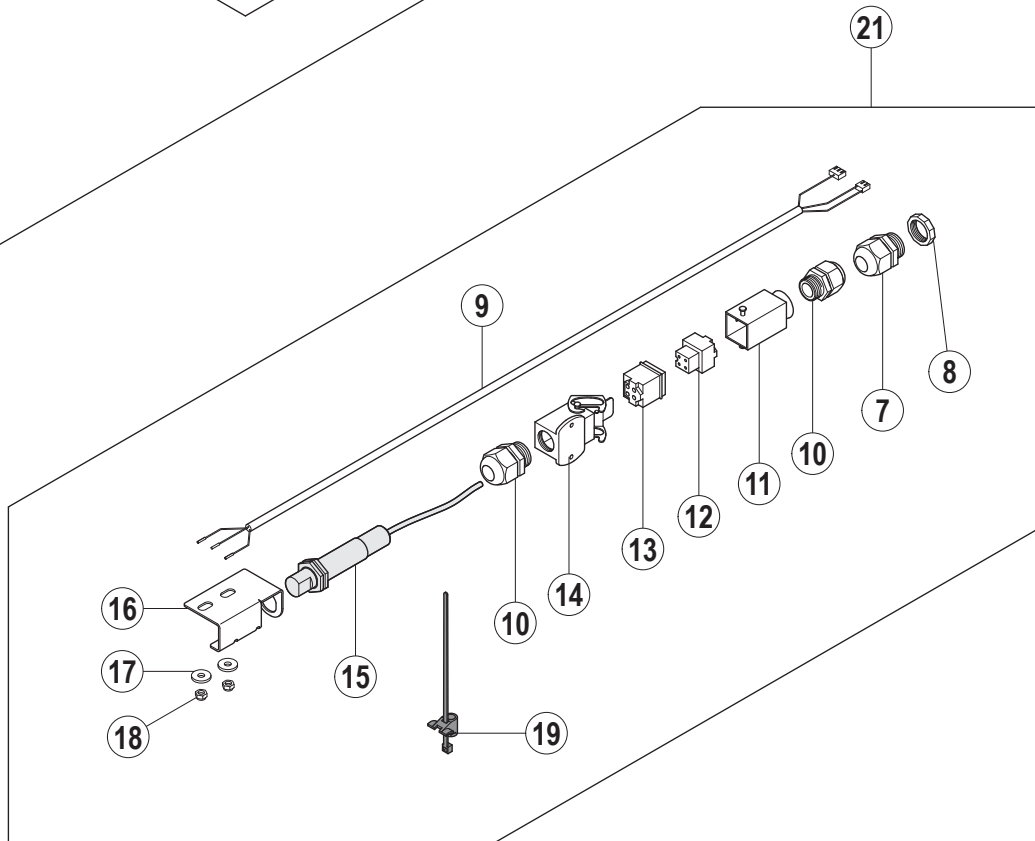

optisch
 optical
 optique



A Laufrichtung
Working direction
Sens de marche

B Maschinen-Grundtyp
Basic machine
Machine de base

X Länge
Length
Longueur

Pos.	A	B			X [mm]	Bemerkung / Remarks / Remarques
		CS	CN	CP		
01		00-896493-001	=	=		mit / with / avec 00-785410-001
		01-518205-001	=	=		mit / with / avec 00-785286-001
02		00-735084-001	=	=		
03		00-735085-003	=	=		
04		00-228694-014	=	=		
05		00-609472-000	=	=		
06		00-785410-001	=	=		siehe Schaltplan / see wiring diagram / voir schéma de câblage
		00-785286-001				siehe Schaltplan / see wiring diagram / voir schéma de câblage
07		00-695661-003	=	=		M20
08		00-695664-003	=	=		M20
09		00-691928-002	=	=		
10		00-324304-003	=	=		PG11
11		00-785090-003	=	=		
12		00-785090-004	=	=		
13		00-785090-005	=	=		
14		00-785090-001	=	=		
15		00-691927-001	=	=		
16		00-886535-001	=	=		
17		00-602318-000	=	=		
18		00-602501-000	=	=		
19		00-691923-001	=	=		
20		01-296170-001	=	=		mechanisch / mechanical / mécanique
		01-296170-004	=	=		mechanisch für Schwenktisch / mechanical for swing-aside table / mécanique pivoter table
21		01-296170-002	=	=		optisch / optical / optique
		01-296170-003	=	=		optisch für Schwenktisch / optical for swing-aside table / optique pivoter table

CS / CN / CP

Vorhänge

Curtains

Rideaux

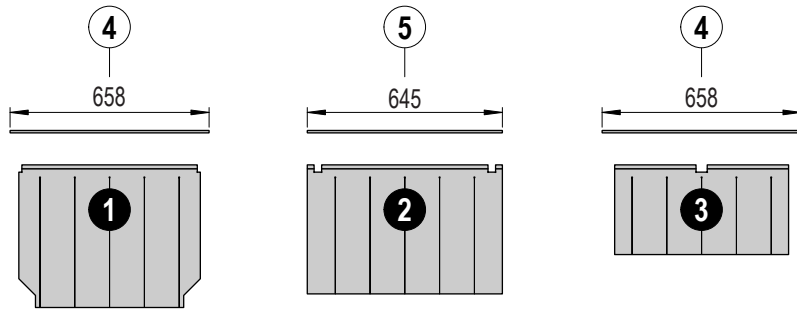

Module / Modules

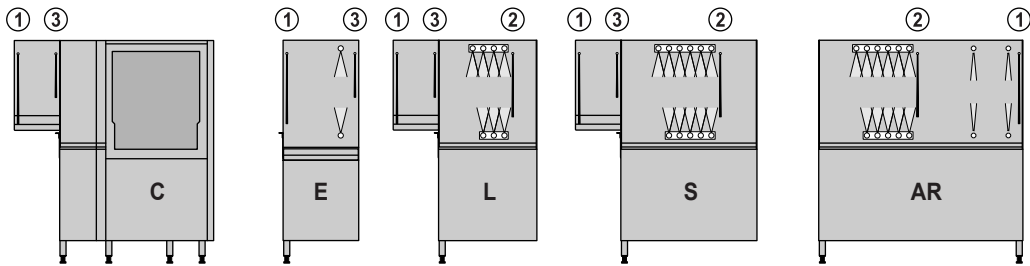

Beispiele / Exemples / Exemples

CS

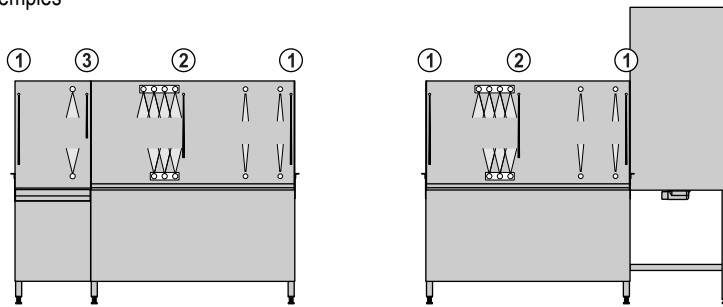

Beispiele / Exemples / Exemples

CN

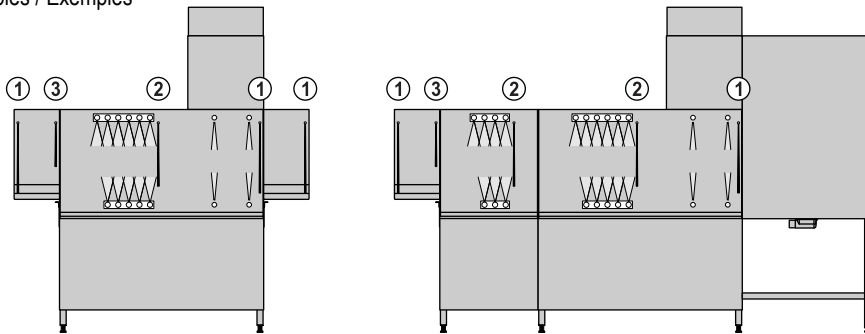

Beispiel / Example / Exemple

CP

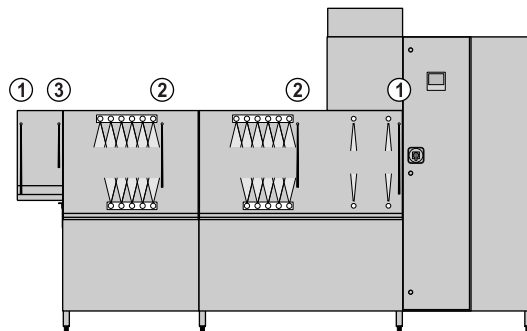

Pos.	A	B			X [mm]	Bemerkung / Remarks / Remarques
		CS	CN	CP		
01		01-291315-001	=	=		
02		01-291315-003	=	=		
03		01-291315-002	=	=		
04		01-245396-007	=	=		
05		01-245396-006	=	=		

HOBART behält sich das Recht vor, an allen Produkten technische Änderungen und Verbesserungen ohne Ankündigung vorzunehmen.

As continued product improvement is a policy of HOBART, specifications are subject to change without notice.

Ce catalogue n'est pas contractuel. HOBART se réserve le droit, et sans préavis, d'apporter toutes modifications ou améliorations à ses matériels.