



**Behälter-Waschanlage**

**Container Washer**

**Machine à laver industrielle  
à convoyeur**



**FUX-C**

**ERSATZTEILE  
SPARE PARTS  
PIECES DETACHEES**

Ab Serien-Nummer:  
Starting from Serial No.:  
A partir du no. de série:  
**8662 0001**

REV. 02.07.2012

Die in diesem Katalog aufgeführten Elektroteile beziehen sich auf folgende Anschluss-Spannungen:  
Electrical components listed in this catalogue are rated for the following supply voltages:  
Les composants électriques énumérés dans ce catalogue sont prévus pour les tensions suivantes:

**400V / 50Hz / 3 / PE**

Bei nicht aufgeführten Anschluss-Spannungen bitte den, der Maschine beigelegten Schaltplan beachten.  
For other voltages, refer to the wiring diagram shipped with the machine.  
Pour d'autres tensions, se référer au schéma électrique envoyé avec la machine.

	<b>ERKLÄRUNG</b>	<b>LEGEND</b>	<b>LEGENDE</b>
<b>1</b>	Verschleißteile	Wearing parts	Pièces d'usure
<b>1</b>	Betriebswichtige Ersatzteile	Recommended spare parts	Pièces de rechange pour maintenance
(L / R)	Laufrichtung links / rechts	Operation direction left / right	Sens de marche gauche / droite
(R / L)	Laufrichtung rechts / links	Operation direction right / left	Sens de marche droite / gauche

---

<b>Inhalt</b>	<b>Kapitel</b>
Zu- und Auslauf .....	01
Waschmodul .....	02
Spülmodul und Schaltkasten .....	03
Erhitzer .....	04
Füllsystem .....	05
Türen und Verkleidungen .....	06
Absaugung / Wärmerückgewinnung .....	07
Ausblasmodul .....	08
Transportsystem .....	09
Dampfverrohrung .....	10
Zubehör (optional) .....	11

---

<b>Content</b>	<b>Chapter</b>
Entry and exit section .....	01
Wash module .....	02
Rinse module and Control box .....	03
Booster .....	04
Filling system .....	05
Doors and Panels .....	06
Exhaust / Heat recovery .....	07
Blower module .....	08
Conveyor system .....	09
Steam piping .....	10
Accessories (optional) .....	11

---

<b>Sommaire</b>	<b>Chapitre</b>
Zone de chargement et déchargement .....	01
Module de lavage .....	02
Module de rinçage et Coffret électrique.....	03
Chaudière .....	04
Système de remplissage .....	05
Portes et panneaux .....	06
Extraction / Récupération de la chaleur.....	07
Module de soufflage .....	08
Système du convoyeur.....	09
Tuyauterie vapeur .....	10
Accessoires (optionnel) .....	11

---



**FUX-C****Zu- und Auslauf****Entry and exit section****Zone de chargement et  
déchargement**

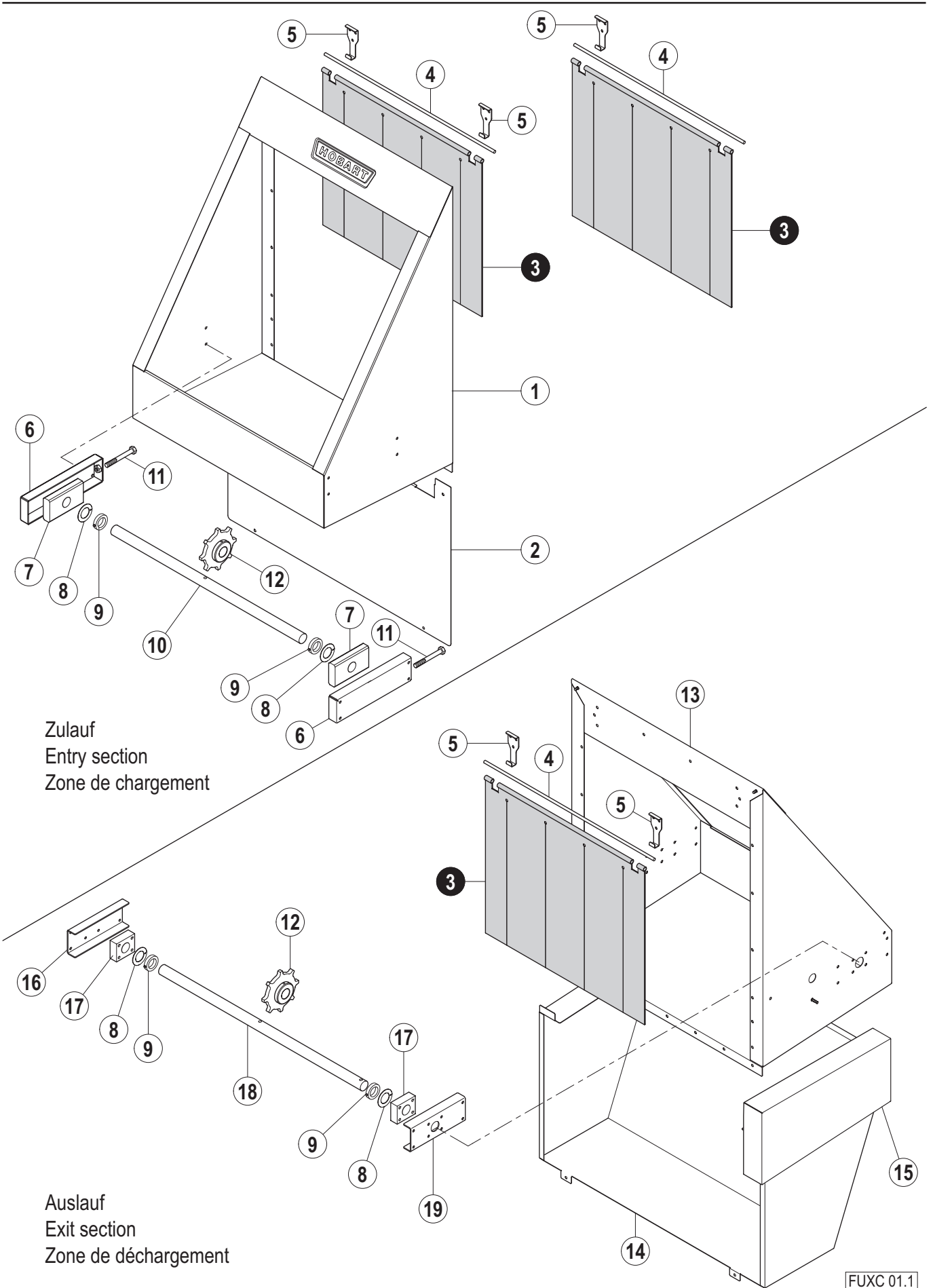

Zulauf  
Entry section  
Zone de chargement

Auslauf  
Exit section  
Zone de déchargement



**A** Laufrichtung  
Working direction  
Sens de marche

**B** Maschinen-Grundtyp  
Basic machine  
Machine de base

Pos.	A	B		Bemerkung / Remarks / Remarques
		FUX-C		
01		01-291625-001		
02		01-291629-001		
03		01-245397-023		
04		01-245396-007		
05		01-245395-001		
06		00-884539-001		
07		00-884542-001		
08		00-696323-001		
09		00-600549-000		
10		01-291627-002		
11		00-603546-000		
12		00-735865-001		
13		01-291625-002		
14		01-291628-001		
15		01-291631-001		
16		00-884540-002		
17		00-884541-001		
18		01-291627-001		
19		00-884540-001		





---

**FUX-C**  
**Waschmodul**  
**Wash module**  
**Module de lavage**

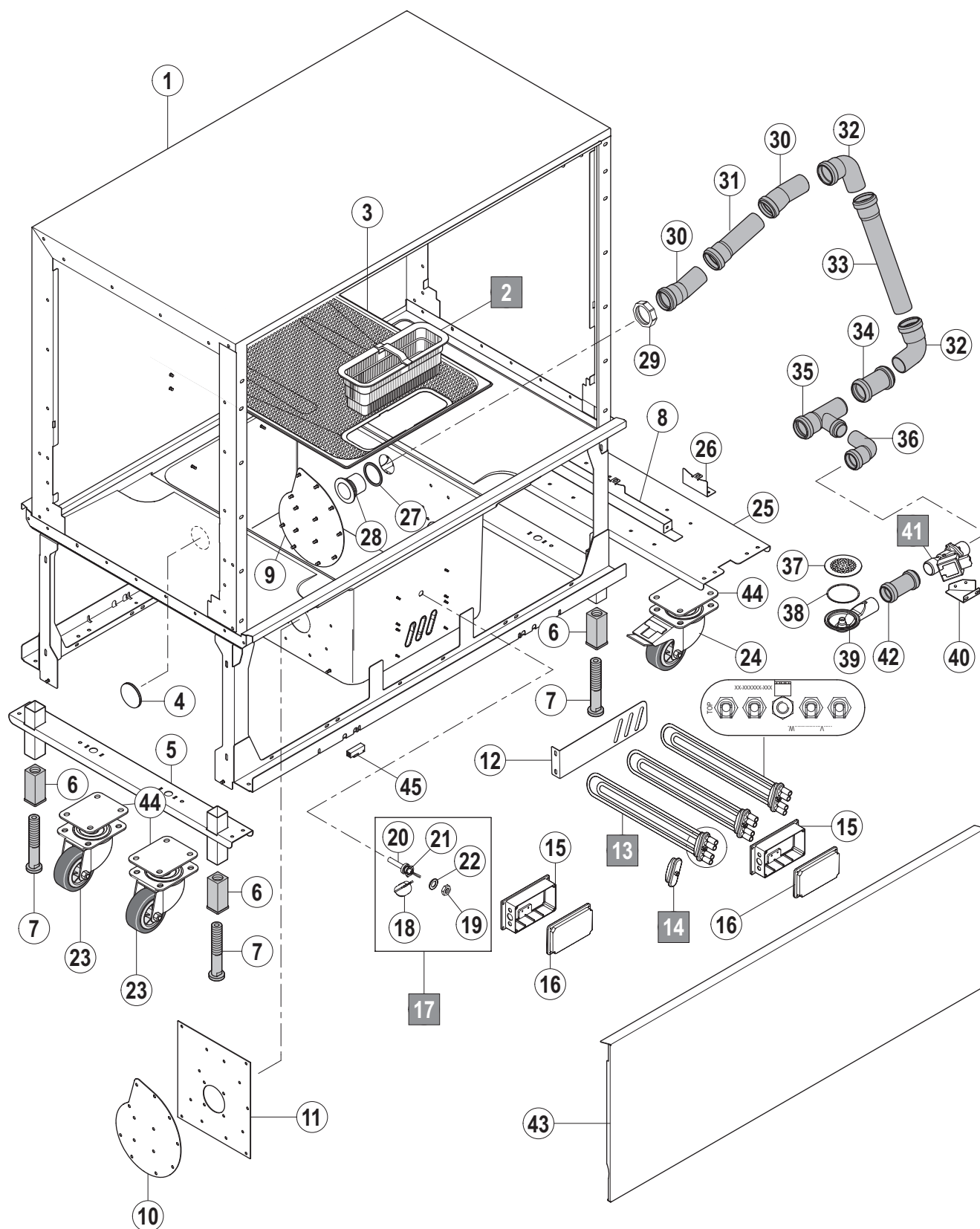



Laufrichtung  
**A** Working direction  
 Sens de marche

Maschinen-Grundtyp  
**B** Basic machine  
 Machine de base

Pos.	A	B		Bemerkung / Remarks / Remarques
		FUX-C		
01	L/R	01-296030-001		
	R/L	01-296030-002		
	L/R	01-296030-003		fahrbar / mobile (mit Rollen / with castors / avec roues pivotantes)
	R/L	01-296030-004		fahrbar / mobile (mit Rollen / with castors / avec roues pivotantes)
02		01-245170-010		
		01-245867-001		CrNi / SST / inox
03		01-245047-001		
04		01-245679-001		
05		01-245452-002		
06		00-325008-001		
07		00-325007-001		
08		01-245768-004		
09		01-245780-001		
10		01-245779-001		
11		01-245386-001		
12		01-245372-001		
13		00-324637-...		Nr. siehe Flansch / no. see flange / no. voir bride
14		00-774808-001		
15		01-245373-001		
16		01-245374-001		
17		01-245621-004		<b>Easytronic</b> ( $\leq$ Serial Nr. / Serial No. / no. de série 8662 0115)
17		01-296000-001		<b>Smartronic</b> ( $\geq$ Serial Nr. / Serial No. / no. de série 8662 0116)
18		00-122674-000		
19		00-602476-000		
20		00-226282-000		
21		00-112467-000		
22		00-168611-021		
23		00-154079-001		ohne Stopper / without stopper / sans frein
24		00-154079-011		mit Stopper / with stopper / avec frein
25		01-296619-001		mit Rollen / with castors / avec roues pivotantes
26		01-296062-001		mit Rollen / with castors / avec roues pivotantes
27		01-245460-001		
28		01-245112-001		
29		01-245165-001		
30		00-377342-001		
31		00-229679-026		
32		00-230080-001		
33		00-229679-028		
34		00-229680-001		
35		00-323593-002		
36		00-230080-002		
37		01-245107-001		
38		01-245340-004		
39		01-245109-001		
40		01-245294-001		
41		00-774683-...		siehe Schaltplan / see wiring diagram / voir schéma de câblage
42		00-692283-002		
43		01-245190-002		
44		01-296128-001		
45		00-775491-001		

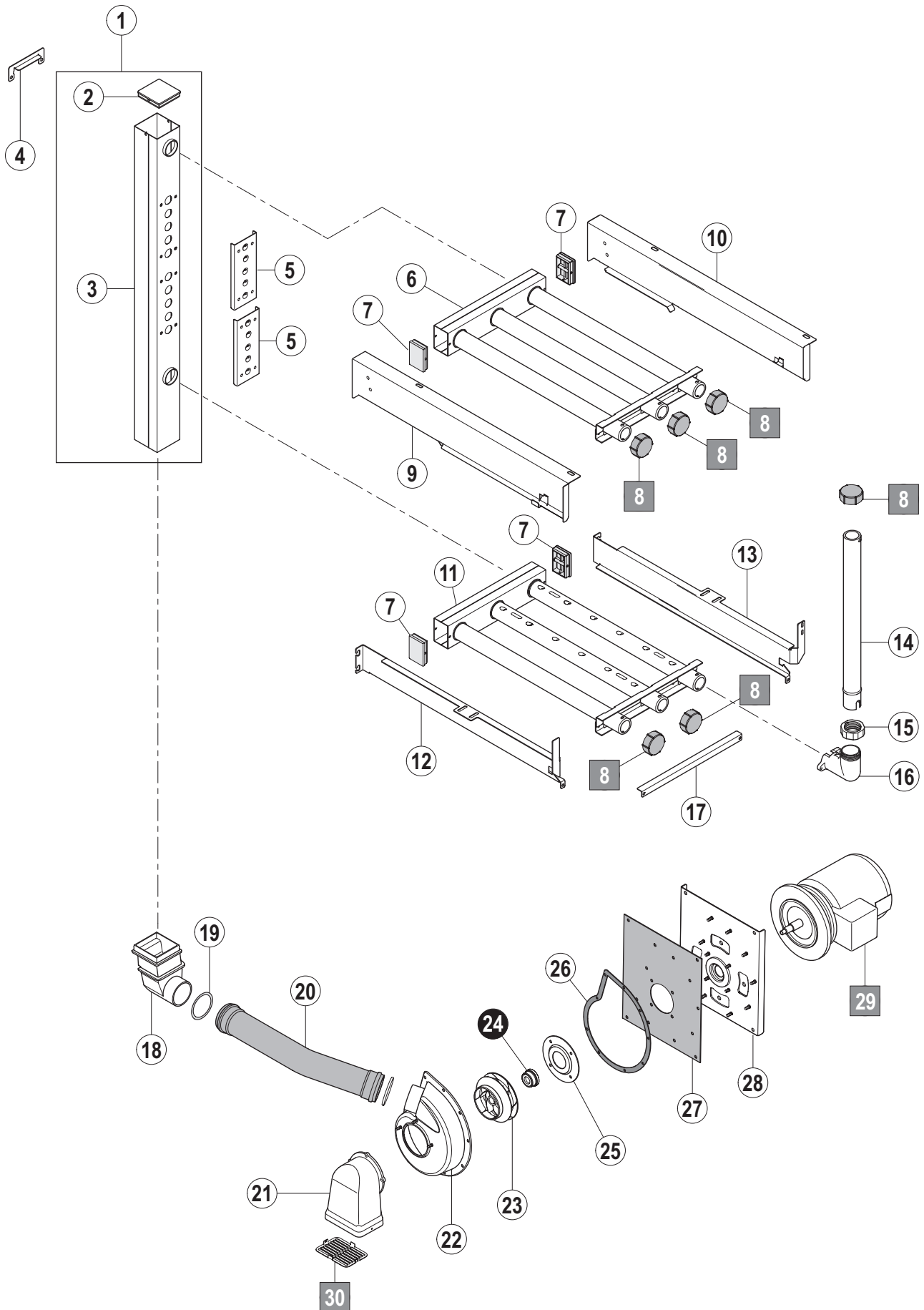

Pos.	A	B		Bemerkung / Remarks / Remarques
		FUX-C		
01		01-245669-001		
02		01-245086-002		
03		01-245110-004		
04		01-245979-001		
05		01-245428-002		
06		01-245106-028		
07		01-245086-001		
08		01-245084-001		
09		01-245332-007		
10		01-245333-007		
11		01-245106-027		
12		01-291642-001		
13		01-291642-002		
14	R/L	01-296209-001		
14	L/R	01-296209-002		
15		01-245424-001		
16		01-245423-001		
17		01-291644-001		
18		01-245055-001		
19		01-245340-003		
20		01-245277-002		
21		01-245713-001		
22		01-245135-002		
23		01-245088-002		
24		01-245033-002		
25		01-245379-001		
26		01-245459-001		
27		01-245386-001		
28		01-245835-001		
29		01-245176-...		siehe Schaltplan / see wiring diagram / voir schéma de câblage
30		01-245377-002		



**FUX-C****Spülmodul und Schaltkasten****Rinse module and Control box****Module de rinçage et Coffret  
électrique**

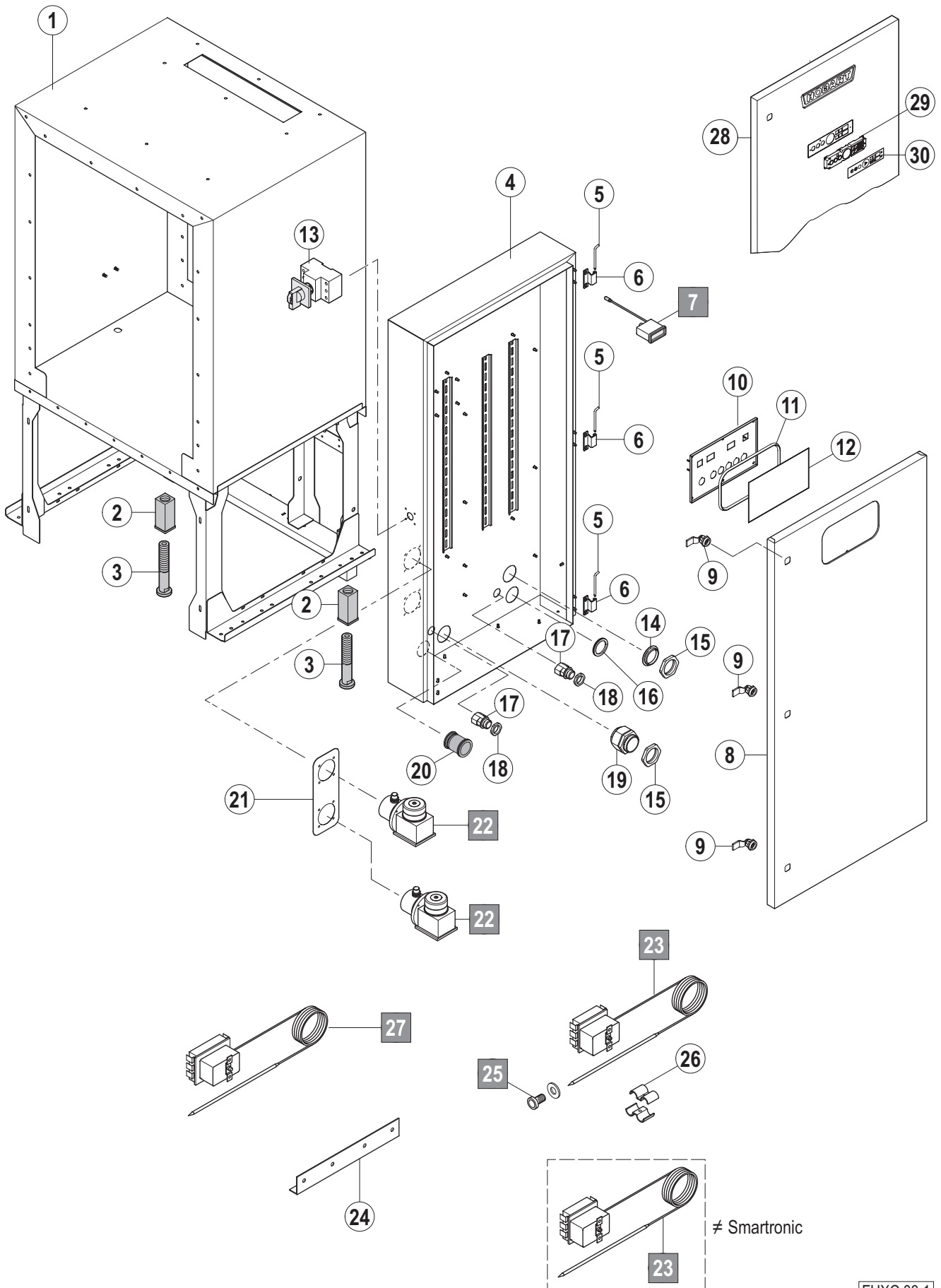



Pos.	A	B		Bemerkung / Remarks / Remarques
		FUX-C		
01		01-291654-001		
		01-291654-002		fahrbar / mobile (mit Rollen / with castors / avec roues pivotantes)
02		00-325008-001		
03		00-325007-001		
04		01-296100-001		
05		00-325086-013		
06		00-325089-011		
07		00-228720-003		Easytronic
08		01-245304-012		Easytronic
09		00-229518-001		
10		00-868199-002		Easytronic
11		00-325554-003		Easytronic
12		01-296065-001		Easytronic
13		00-230040-001		
14		00-695666-007		
15		00-695664-007		
16		00-325655-001		
17		00-774797-002		
18		00-695664-004		
19		00-695661-007		
20		00-325186-001		
21		01-291636-001		
22		00-736157-001		
23		00-897927-000		Easytronic ( $\leq$ Serial Nr. / Serial No. / no. de série 8662 0115)
23		00-775612-003		Smartronic ( $\geq$ Serial Nr. / Serial No. / no. de série 8662 0116)
24		01-244458-001		
25		00-227024-000		
26		00-324157-000		
27		00-887020-001		nur mit Metzgerei-Kit / only with butchery kit / seulement avec kit de boucherie
28		01-245304-024		Smartronic
29		00-897540-002		Smartronic
30		01-291845-001		Smartronic

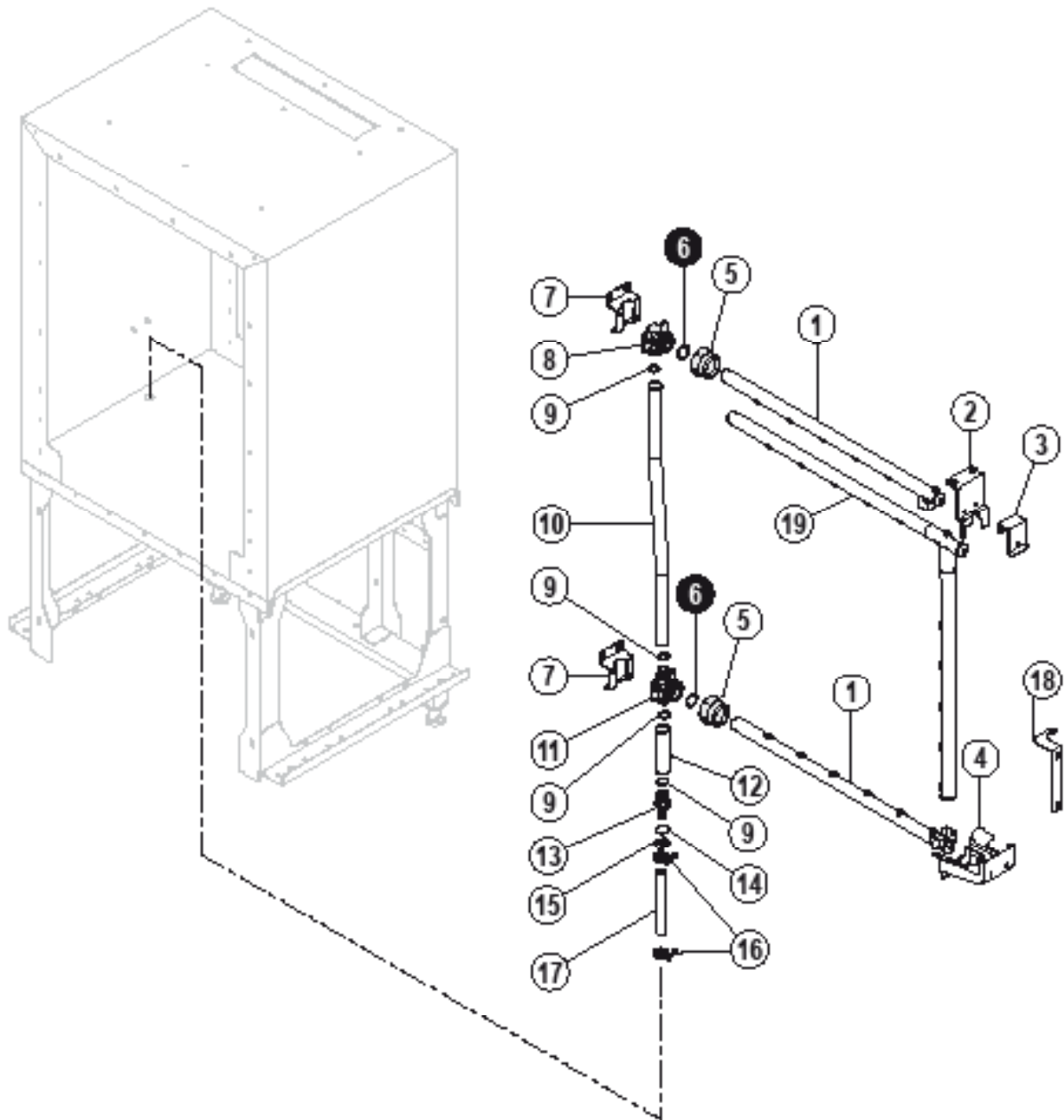

Pos.	A	B		Bemerkung / Remarks / Remarques
		FUX-C		
01		01-245255-004		
02		01-291495-001		
		01-245063-007		Spülung seitlich / rinsing at the side / rinçage latéral
03		01-245062-001		
04		01-291652-001		
05		00-885572-001		
06		00-884505-002		
07		01-291337-001		
08		01-245318-002		
09		01-245340-001		
10		01-245323-002		
		01-518473-001		Spülung seitlich / rinsing at the side / rinçage latéral
11		01-245318-001		
12		01-291297-004		
13		01-245329-001		
14		01-245340-002		
15		00-172739-009		
16		00-323945-022		
17		01-245571-014		L = 500 mm
18		01-296762-002		Spülung seitlich / rinsing at the side / rinçage latéral
19		01-296627-012		Spülung seitlich / rinsing at the side / rinçage latéral



**FUX-C**  
**Erhitzer**  
**Booster**  
**Chaudière**

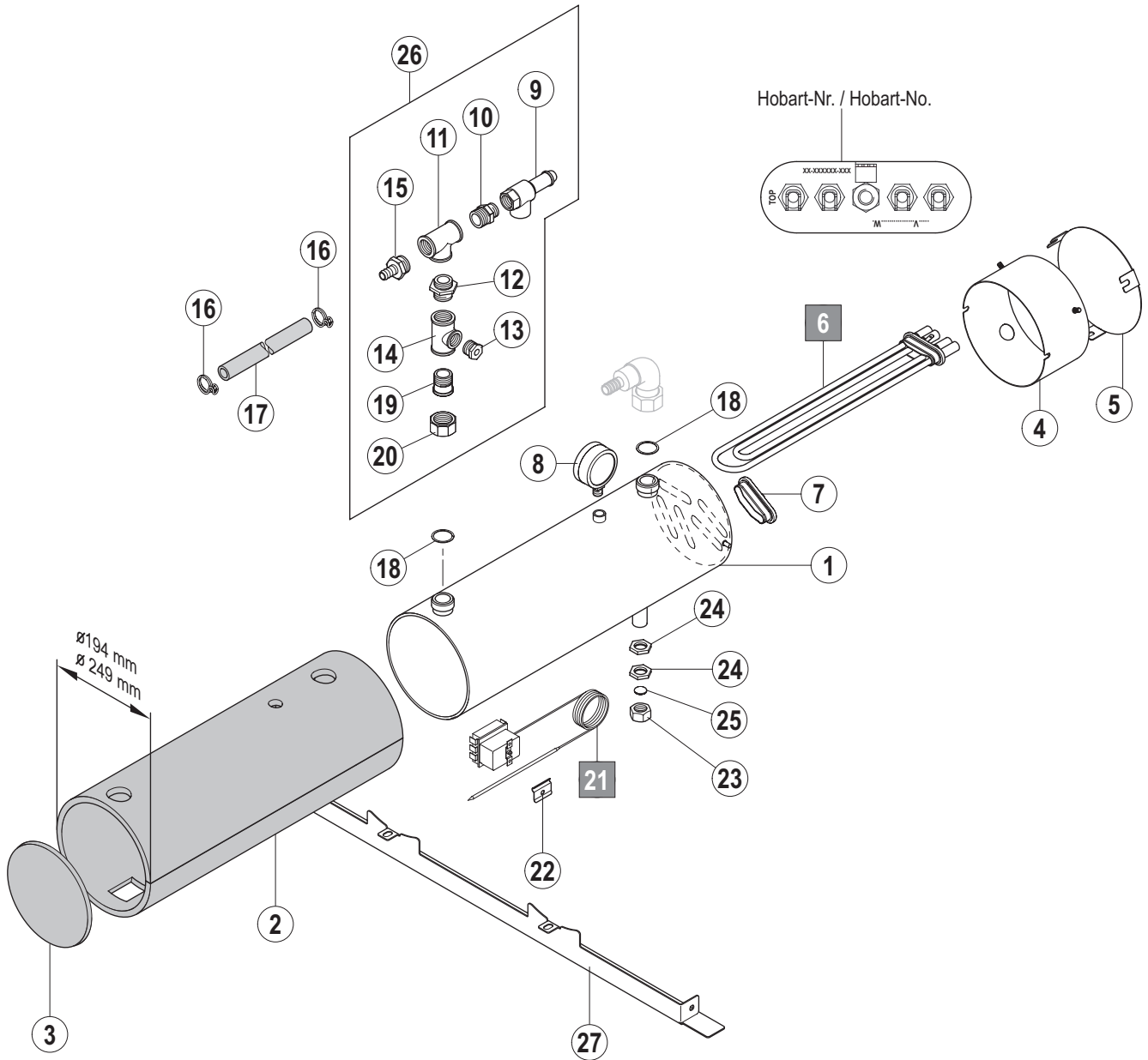

Pos.	A	B		Bemerkung / Remarks / Remarques
		Ø194	Ø249	
01		00-897637-001	01-241855-001	
02		00-897657-001	01-241874-001	
03		00-897657-002	01-241876-001	
04		01-249044-001	01-249043-001	
05		01-249044-002	01-249043-002	
06				Nr. siehe Flansch / no. see flange / no. voir bride
07		00-774808-001	=	
08		00-229583-001	=	
09		00-229621-000	=	
10		00-602757-000	=	
11		00-603163-000	=	
12		00-227931-000	=	
13		01-291287-001	=	
14		01-291288-001	=	
15		00-897680-001	=	
16		00-323945-022	=	
17		01-245571-002	=	
18		00-168611-003	=	
19		01-291286-001	=	
20		00-600806-000	=	
21		00-897927-000	=	Easytronic ( $\leq$ Serial Nr. / Serial No. / no. de série 8662 0115)
21		00-775612-003	=	Smartronic ( $\geq$ Serial Nr. / Serial No. / no. de série 8662 0116)
22		00-775489-001	=	
23		00-600588-000	=	
24		00-172739-001	=	
25		00-168611-022	=	
26		01-245435-001	=	
27		01-245768-004	=	

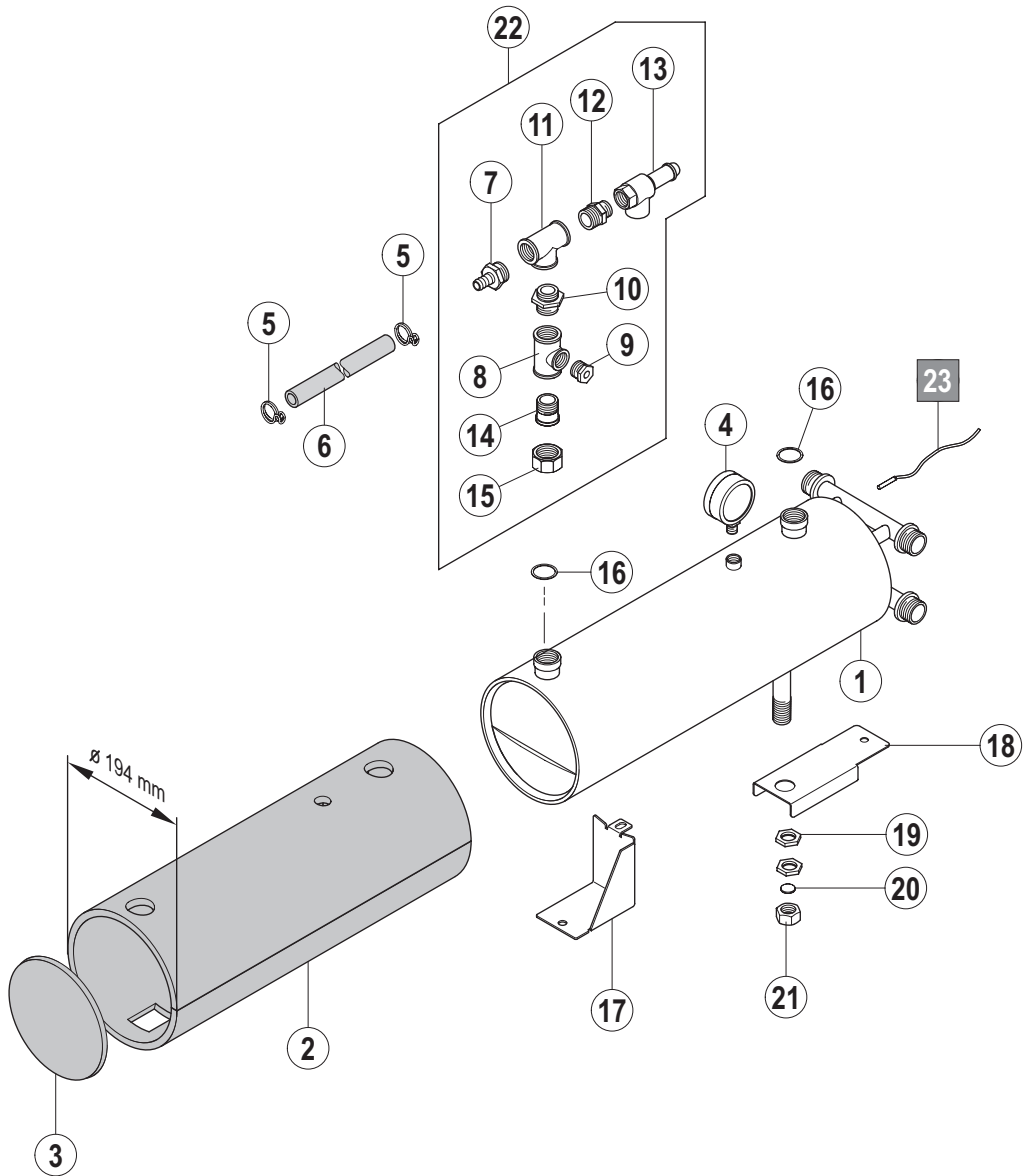



Pos.	A	B		Bemerkung / Remarks / Remarques
		Ø194	Ø249	
1		01-245564-001		
2		00-897657-001		
3		00-897657-002		
4		00-229583-001		
5		00-323945-022		
6		01-245571-002		
7		00-897680-001		
8		01-291288-001		
9		01-291287-001		
10		00-227931-000		
11		00-603163-000		
12		00-602757-000		
13		00-229621-000		
14		01-291286-001		
15		00-600806-000		
16		00-168611-003		
17		01-245299-002		
18		01-245298-001		
19		00-172739-001		
20		00-168611-022		
21		00-600588-000		
22		01-244435-001		
23		00-378584-000		



**FUX-C**

**Füllsystem**

**Filling system**

**Système de remplissage**

05.1

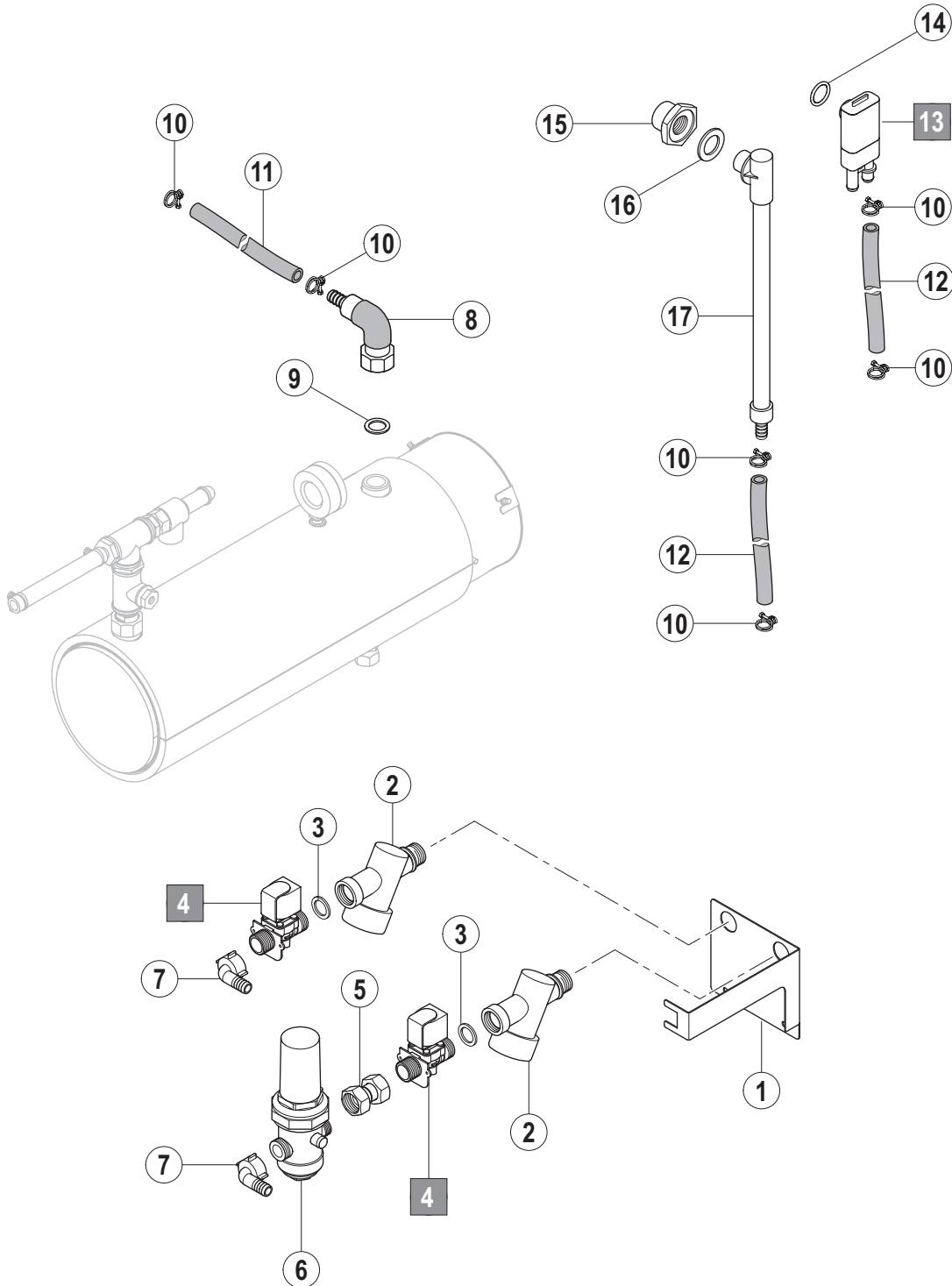

Pos.	A	B		Bemerkung / Remarks / Remarques
		FUX-C		
01		01-291632-001		
02		00-774810-001		
03		00-168611-009		
04		00-297808-001		
05		01-244417-001		
06		00-229110-002		
07		00-229240-001		
08		01-245560-001		
09		00-168611-003		
10		00-325945-022		
11		01-245571-014		L = 500 mm
12		01-245571-002		L = 2000 mm
13		00-775759-001		
14		00-884505-002		
15		00-774670-001		
16		00-172986-027		
17		00-89768-001		

05.2

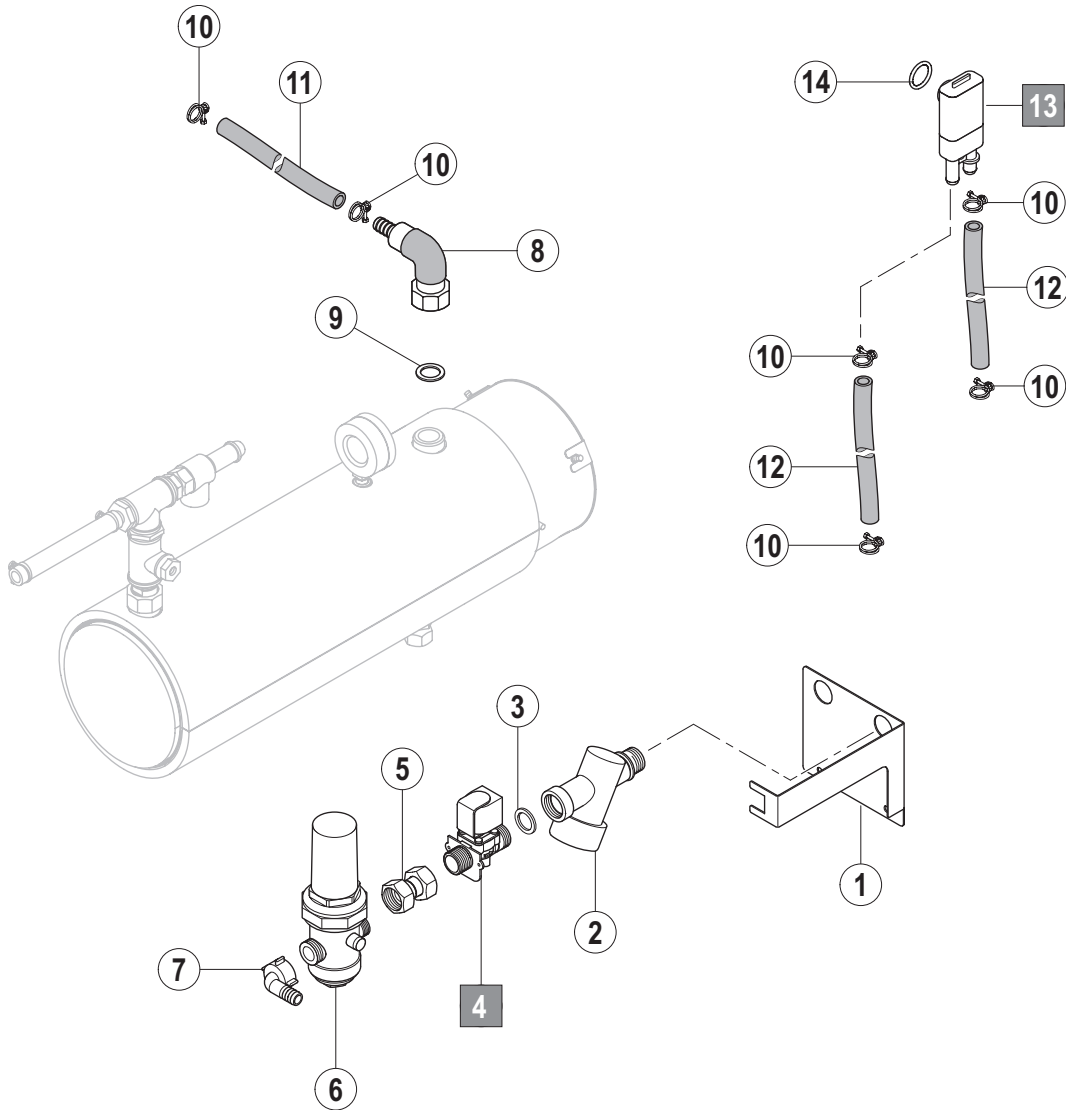

FUXC 05.2







**FUX-C****Türen und Verkleidungen****Doors and Panels****Portes et panneaux**

06.1

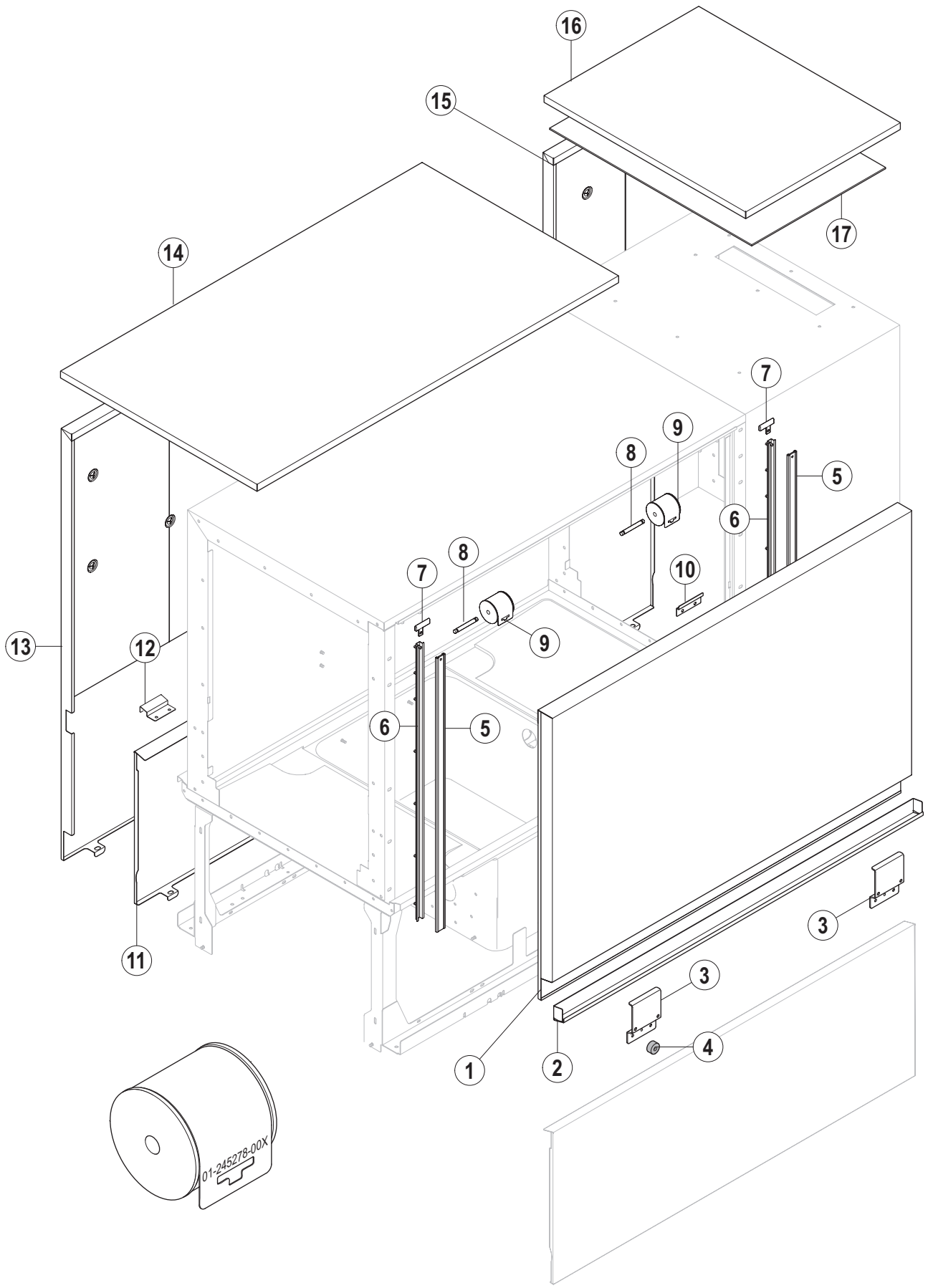

Pos.	A	B		Bemerkung / Remarks / Remarques
		FUX-C		
01		01-245754-004		mit Isolierung / with insulation / avec isolation
		01-296164-001		ohne Isolierung / without insulation / sans isolation
02		01-245129-004		
03		01-245127-001		
04		00-774714-001		
05		00-325064-007		
06		01-245126-002		
07		01-291426-001		
08		01-245281-001		
09		01-245278-008		
10		01-245317-001		
11		01-245190-006		
12		01-296027-001		
13		01-245527-005		
14		01-245525-001		
15		01-245527-012		
16		01-245525-023		
17		01-291656-001		

06.1



**FUX-C**

**Absaugung / Wärmerück-  
gewinnung**

**Exhaust / Heat recovery**

**Extraction / Récupération de la  
chaleur**

07.1

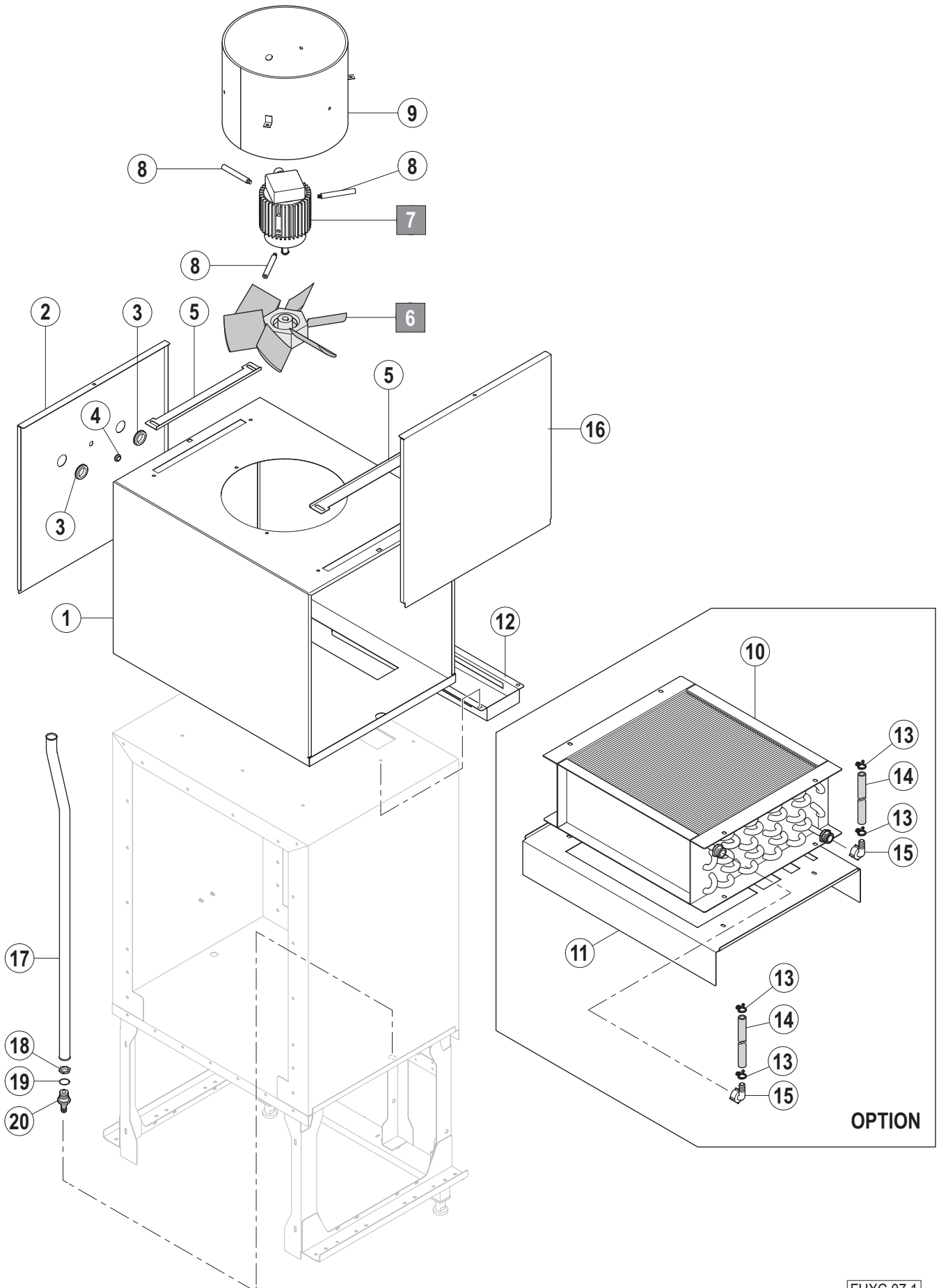

FUXC 07.1

Pos.	A	B		Bemerkung / Remarks / Remarques
		FUX-C		
01		01-291392-003		
02		01-245206-003		
03		00-227748-004		
04		00-227748-001		
05		01-228336-000		
06		00-038933-010		
07		00-145075-006		siehe Schaltplan / see wiring diagram / voir schéma de câblage
08		00-693877-002		
09		00-229438-001		
10		01-245490-007		Cu
		01-245490-008		CrNi / SST / inox
11		01-245274-004		
12		01-291796-001		
13		00-323945-022		
14		01-245571-002		
15		00-229240-001		
16		01-245206-001		
17		01-245323-004		
18		00-172739-009		
19		01-245340-002		
20		01-245329-001		





**FUX-C****Ausblasmodul****Blower module****Module de soufflage**

08.1

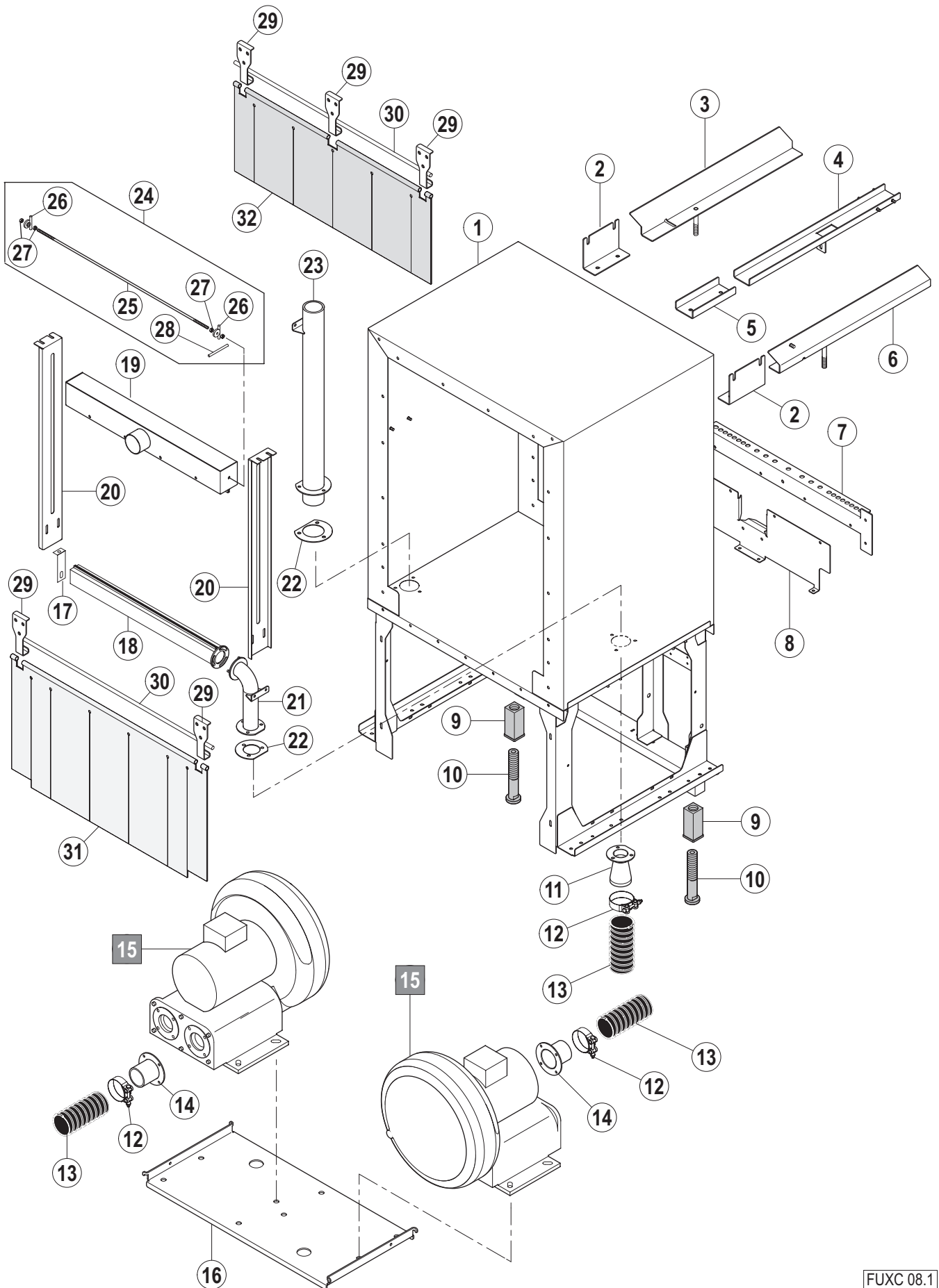

Pos.	A	B		Bemerkung / Remarks / Remarques
		FUX-C		
01		01-291654-003		
02		01-296329-001		
03		01-296325-002		
04		01-296327-001		
05		01-296330-001		
06		01-296325-001		
07		01-291634-001		
08		01-296034-001		
09		00-325008-001		
10		00-325007-001		
11		01-296192-001		
12		00-869038-001		
13		00-783812-001		
14		00-784508-001		
15		00-736921-...		siehe Schaltplan / see wiring diagram / voir schéma de câblage
16		01-296097-002		
17		01-296441-001		
18		00-693220-004		
19		01-296070-004		
20		00-884416-008		
21		01-296098-003		
22		00-692709-002		
23		01-296331-001		
24		00-735821-001		
25		00-697973-004		
26		00-735820-001		
27		00-602491-000		
28		00-698614-010		
29		01-296442-001		
30		01-245396-001		
31		01-245398-001		
32		01-245398-028		

08.2

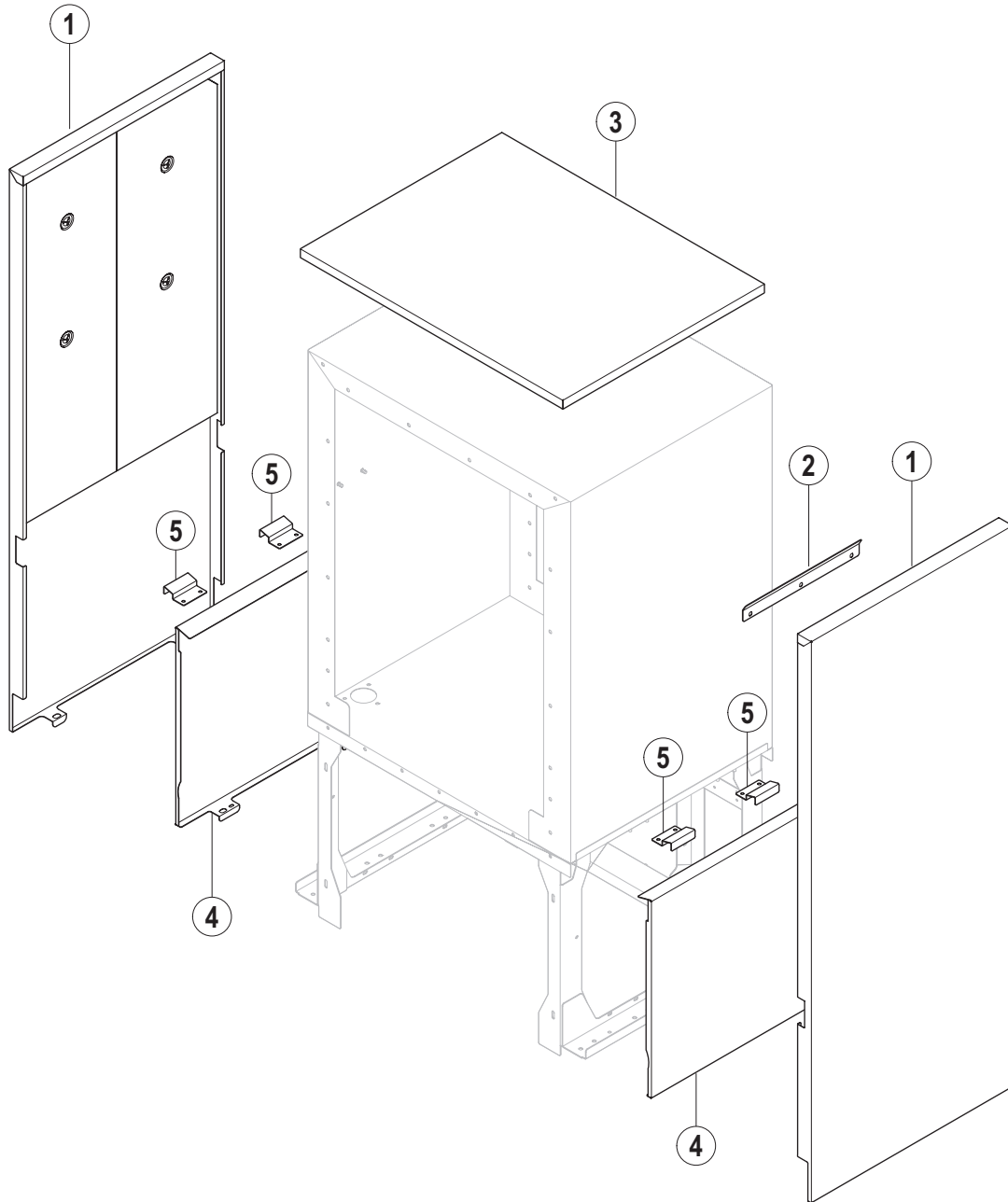

FUXC 08.2





**FUX-C**  
**Transportsystem**  
**Conveyor system**  
**Système du convoyeur**

09.1

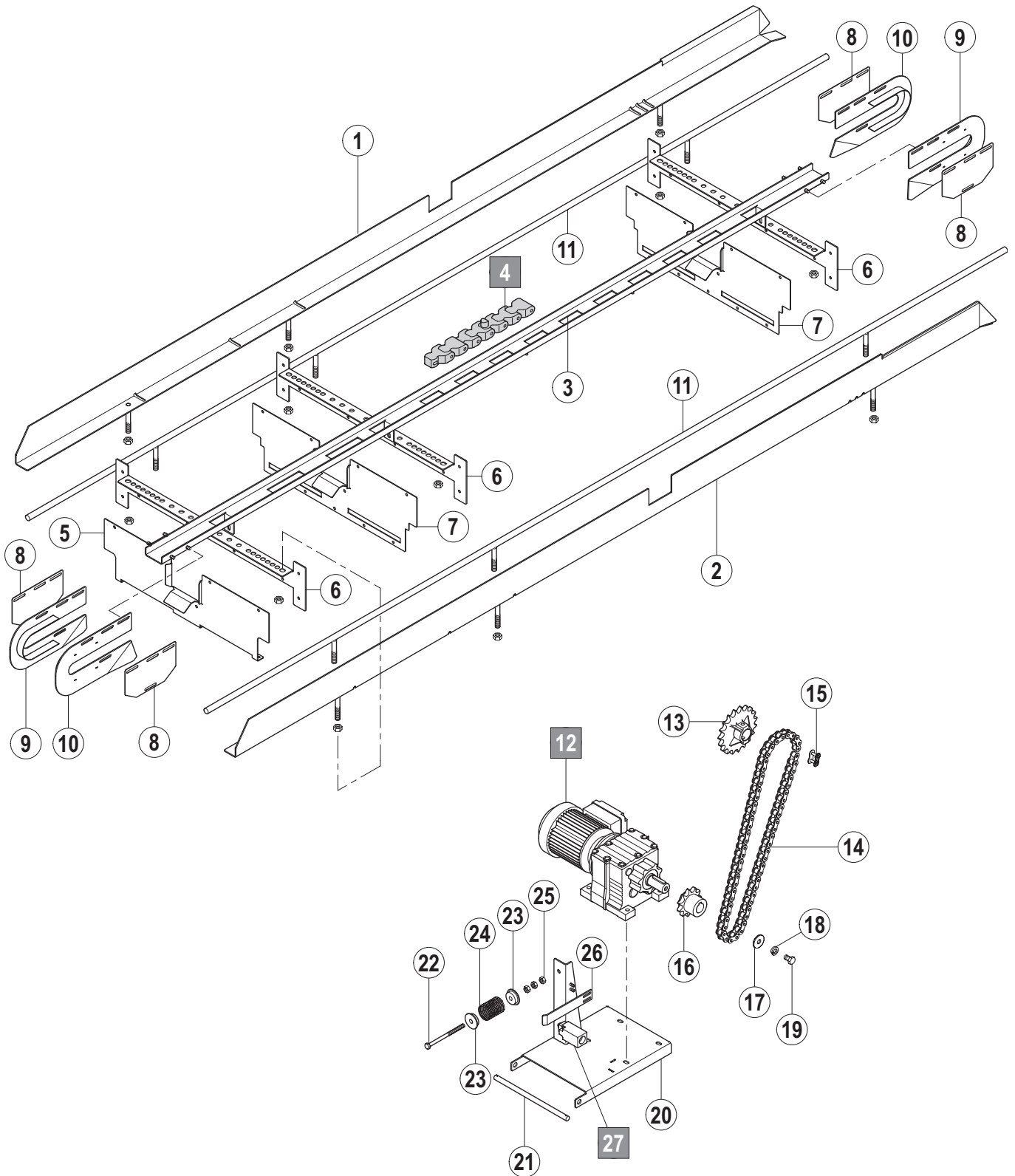

FUXC 09.1



Pos.	A	B		Bemerkung / Remarks / Remarques
		FUX-C		
01	L/R	01-291-640-001		
	R/L	01-291640-003		
02	L/R	01-291640-002		
	R/L	01-291640-004		
03		01-291638-001		
04		00-735864-005		
05		01-296034-001		
06		01-291634-001		
07		01-296032-001		
08		01-291645-001		
09		01-291647-001		
10		01-291647-002		
11		01-296114-001		ohne Ausblasung / without blower / sans soufflage
11		01-296114-002		mit Ausblasung / with blower / avec soufflage
12		01-245344-004		
13		00-168828-001		
14		00-168703-001		
15		00-226485-000		
16		01-241893-003		
17		00-378755-001		
18		00-602295-000		
19		00-602586-000		
20		01-245352-004		
21		01-245412-001		
22		00-603547-000		
23		00-229413-001		
24		00-699383-005		
25		00-602492-000		
26		01-245355-002		
27		00-325189-003		



**FUX-C****Dampfverrohrung****Steam piping****Tuyauterie vapeur**

10.1

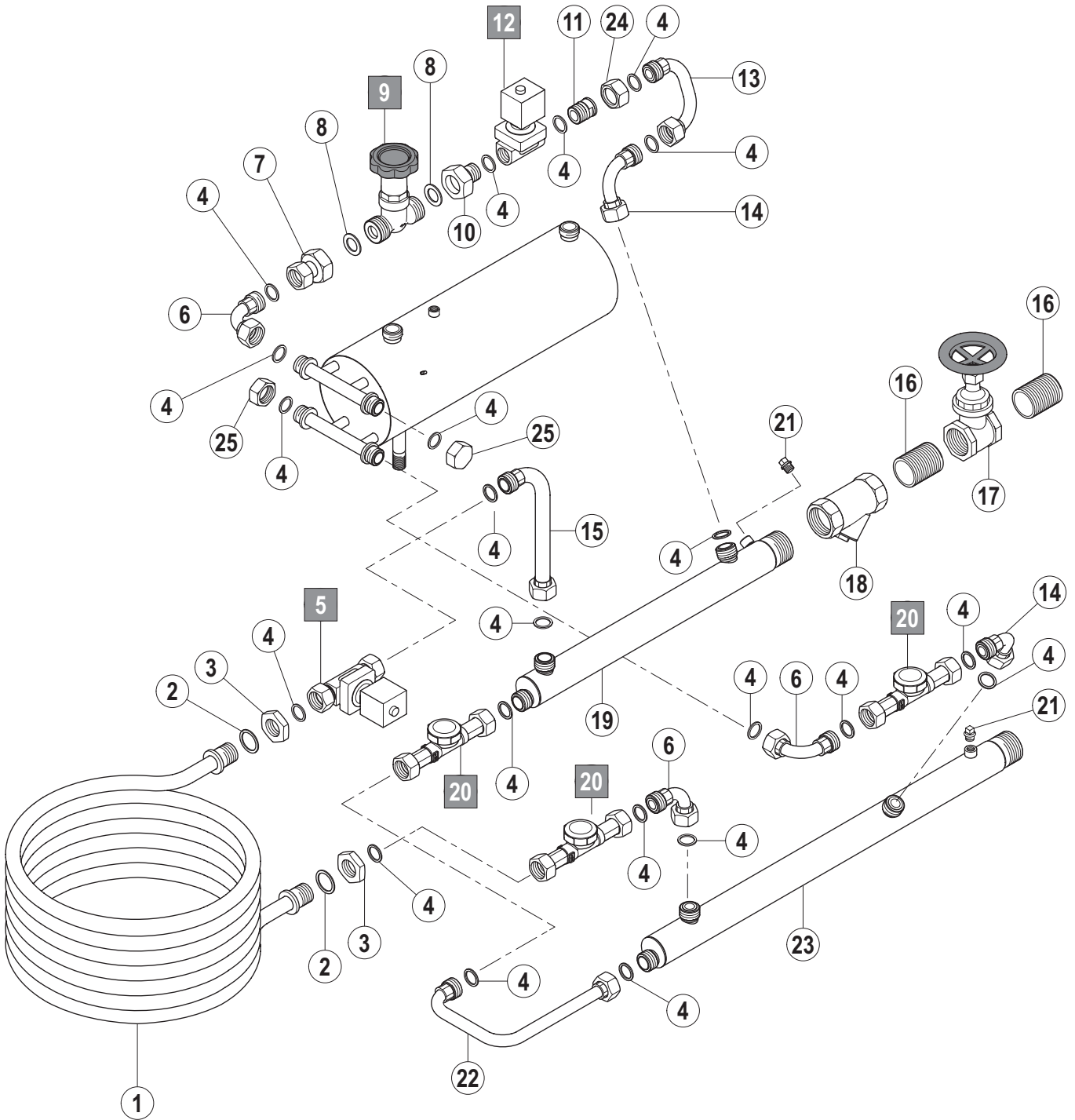

Pos.	A	B		Bemerkung / Remarks / Remarques
		FUX-C		
01		01-245647-001		
02		00-300084-010		
03		00-609698-000		
04		00-302574-014		
05		01-245593-001		Dampf / steam / vapeur 1 - 3,5 bar
		01-245593-002		Dampf / steam / vapeur ≤ 1 bar
06		01-245634-002		
07		01-291947-001		
08		00-302574-001		
09		00-165828-002		
10		01-291946-002		
11		01-245594-001		
12		00-869493-001		Dampf / steam / vapeur 1 - 3,5 bar
		01-296588-001		Dampf / steam / vapeur ≤ 1 bar
13		01-245629-004		
14		01-245634-006		
15		01-245628-001		
16		00-600558-000		
17		00-774420-001		
18		00-774429-001		
19		01-245569-013		
20		01-245603-001		
21		00-603130-000		
22		01-245635-002		
23		01-245591-013		
24		01-245567-001		
25		01-245605-001		

10.2

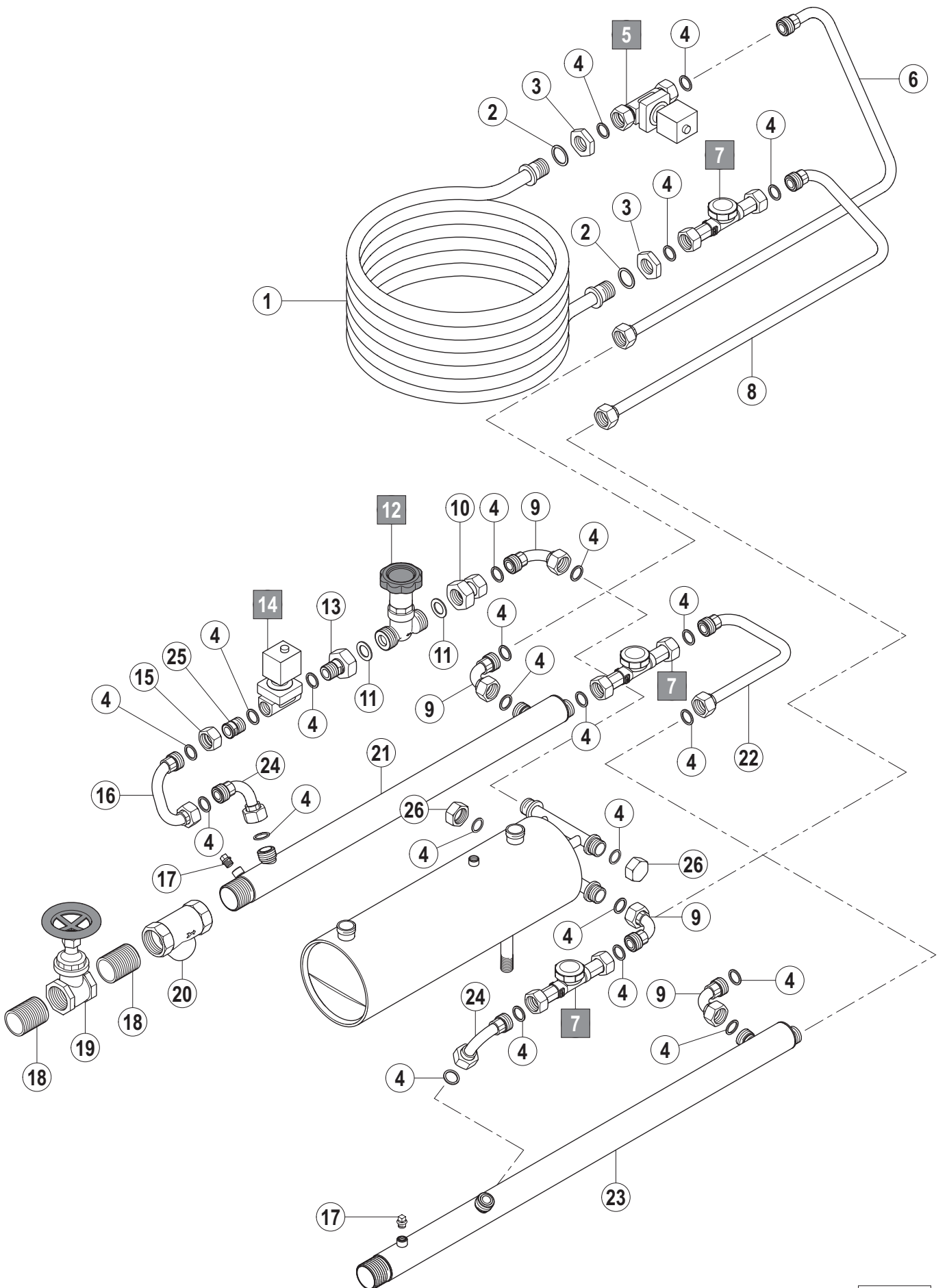

Pos.	A	B		Bemerkung / Remarks / Remarques
		FUX-C		
01		01-245647-001		
02		00-300084-010		
03		00-609698-000		
04		00-302574-014		
05		01-245593-001		Dampf / steam / vapeur 1 - 3,5 bar
		01-245593-002		Dampf / steam / vapeur ≤ 1 bar
06		01-245635-004		
07		01-245603-001		
08		01-245635-003		
09		01-245634-002		
10		01-291947-001		
11		00-302574-001		
12		00-165828-002		
13		01-291946-002		
14		00-869493-001		Dampf / steam / vapeur 1 - 3,5 bar
		01-296588-001		Dampf / steam / vapeur ≤ 1 bar
15		01-245594-001		
16		01-245629-005		
17		00-603130-000		
18		00-600558-000		
19		00-774420-001		
20		00-774429-001		
21		01-245569-014		
22		01-245635-002		
23		01-245591-014		
24		01-245634-006		
25		01-245567-001		
26		01-245605-001		



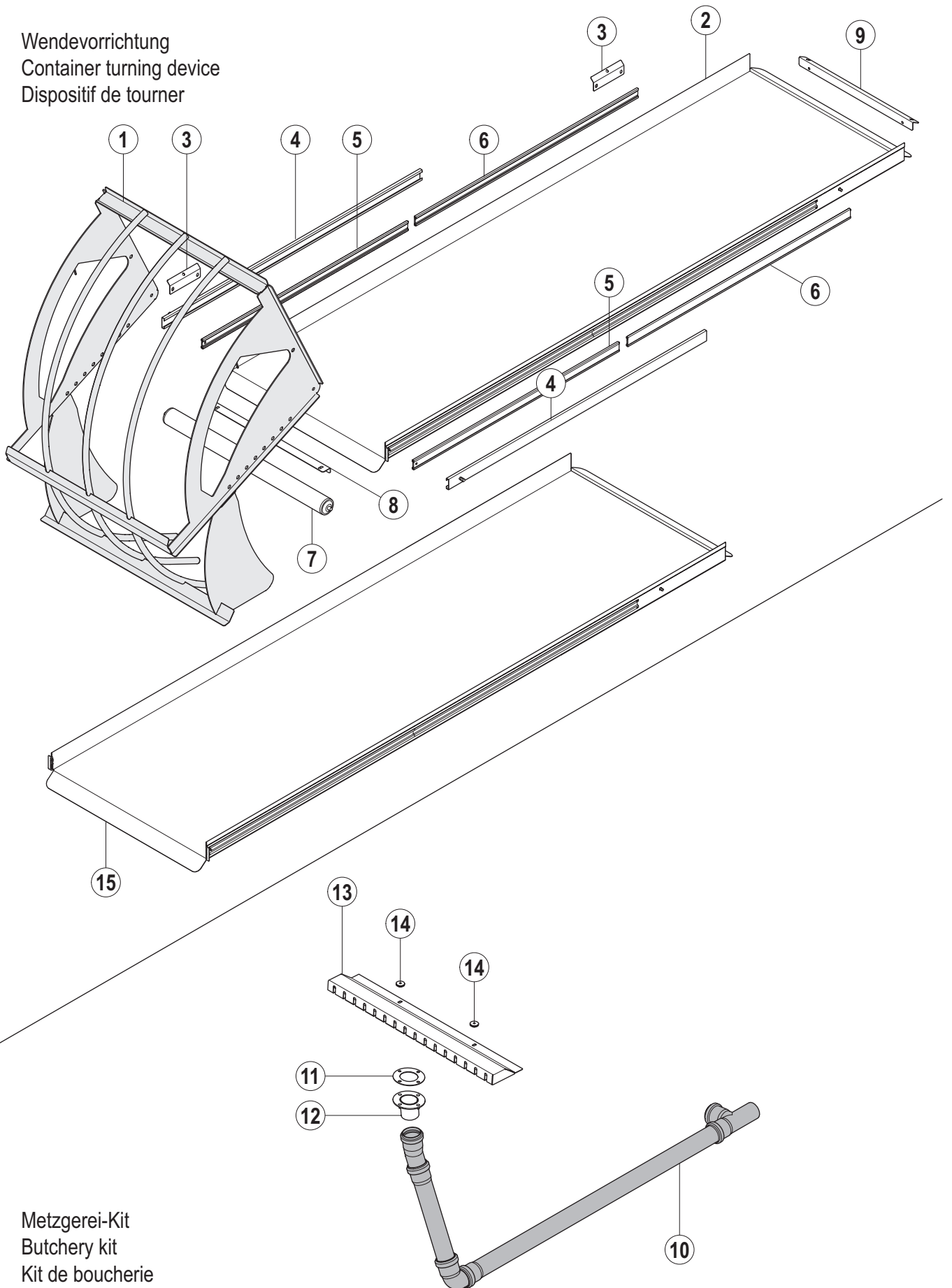

**FUX-C****Zubehör (optional)****Accessories (optional)****Accessoires (optionnel)**

Wendevorrichtung  
Container turning device  
Dispositif de tournerMetzgerei-Kit  
Butchery kit  
Kit de boucherie

Pos.	A	B		Bemerkung / Remarks / Remarques
		FUX-C		
01		01-296084-001		
02		01-296124-001		ohne Ausblasung / without blower / sans soufflage
03		01-296155-001		
04		00-899700-001		
05		00-325064-004		
06		00-325064-001		
07		00-693217-003		
08		01-296147-002		
09		01-296147-001		
10		01-296092-002		
11		00-781007-001		
12		00-899709-001		
13		00-899708-001		
14		00-229525-000		
15		01-296124-002		mit Ausblasung / with blower / avec soufflage

11.2

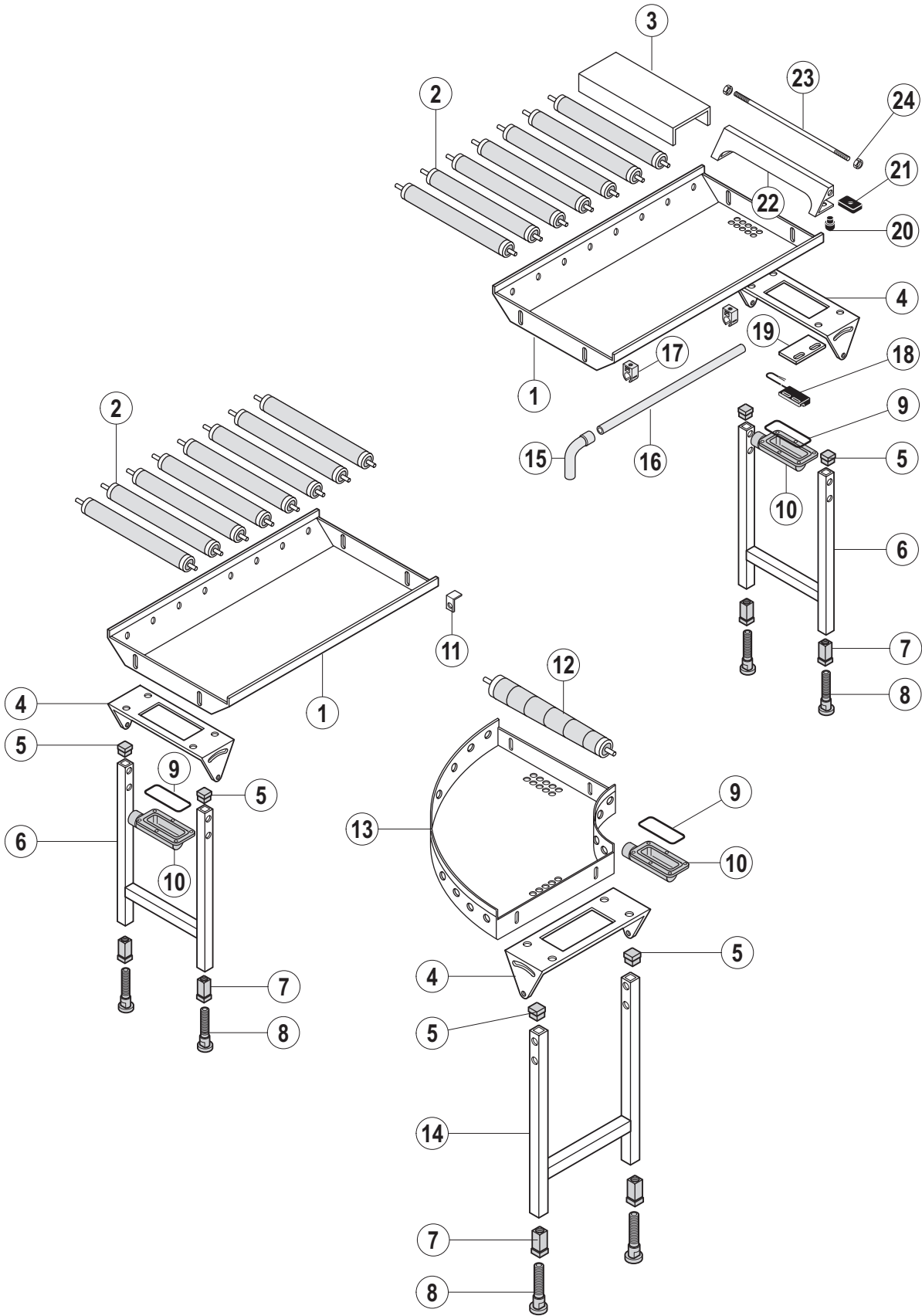

Pos.	A	B		Bemerkung / Remarks / Remarques
		Ø194	Ø249	
01		00-882213-001		L = 1000 mm
		00-882217-001		L = 2000 mm
02		00-882219-001		
03		00-882215-001		
04		00-882192-001		
05		00-371144-001		
06		00-882185-001		
07		00-325008-001		
08		00-325007-001		
09		00-145285-006		
10		00-325529-001		
11		00-882193-001		
12		00-883243-001		konisch / conic / conique
13		00-882246-001		
14		00-882182-001		
15		00-882054-001		
16		00-882290-001		
17		00-882289-001		
18		00-230754-002		
19		00-882218-001		
20		00-324483-000		
21		00-173605-000		
22		00-882193-001		
23		00-882186-001		
24		00-602504-000		

HOBART behält sich das Recht vor, an allen Produkten technische Änderungen und Verbesserungen ohne Ankündigung vorzunehmen.

As continued product improvement is a policy of HOBART, specifications are subject to change without notice.

Ce catalogue n'est pas contractuel. HOBART se réserve le droit, et sans préavis, d'apporter toutes modifications ou améliorations à ses matériels.