

FUX-Serie

Spare Parts
Pièces Détachées
Ersatzteile
Onderdelen

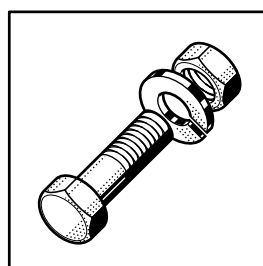

Electrical components listed in this catalogue are rated for the following supply voltages:

Les composants électriques énumérés dans ce catalogue sont prévus pour les tensions suivantes:

Die in diesem Katalog aufgeführten Elektroteile beziehen sich auf folgende Anschlußspannungen:

De in deze catalogus afgebeelde elektrische componenten zijn geschikt voor de volgende aansluitspanningen:

380-415V / 50Hz / 3 / N / PE

380-415V / 60Hz / 3 / N / PE

For other voltages, refer to the wiring diagram shipped with the machine.

Pour d'autres tensions, se référer au schéma électrique envoyé avec la machine.

Bei nicht aufgeführten Anschlußspannungen bitte den, der Maschine beigelegten, Schaltplan beachten.

Voor eventueel andere aansluitspanningen, raadpleeg het elektrische schema welke zich bij de machine bevind.

Contents

Entry section No. 0 +1 + 2	4
Entry section No. 3	8
Entry section No. 0 - 3	10
Entry section - hood	12
Module 1 400 mm	14
Module 900 mm	18
Tank heating and floatswitch I	22
Tank heating and floatswitch II	24
Tank heating (hot water and steam)	26
Wash pump I	28
Wash pump II	30
Wash and prewash system	32
Drain	36
Rinse zone	38
Dual rinse	42
Rinse booster el. heated	46
Rinse booster steam / hot water heated (1m ²)	50
Rinse booster steam / hot water heated (0,6 m ²)	52
Condenser - panels	54
Condenser	56
Exhaust - hood	58
Exhaust - fan	60
Drier section D2	62
Drier section D2A + D2T	64
Drier section - pipework D2 + D2A + D2T	68
Blower	70
Drier section - hood D2 + D2A + D2T	72
Drier section TB2	74
Blower TB2	76
Drier section - hood TB2	78
Drier section TB4	80
Blower TB4	82
Drier section - hood TB4	84
Control boxes	86
Exit section	88
Exit section - conveyor drive I	90
Exit section - conveyor drive II	92

Inhalt

Zulaufstrecke Nr. 0 +1 + 2	4
Zulaufstrecke Nr. 3	8
Zulaufstrecke Nr. 0 - 3	10
Zulaufstrecke - Haube	12
Modul 1 400 mm	14
Modul 900 mm	18
Tankheizung und Schwimmerschalter I	22
Tankheizung und Schwimmerschalter II	24
Tankheizung (Heißwasser und Dampf)	26
Waschpumpe I	28
Waschpumpe II	30
Waschung und Vorwaschung	32
Ablauf	36
Klarspülzone	38
Duoklarspülung	42
Durchlauferhitzer el. beheizt	46
Durchlauferhitzerdampf- / heißwasser-beheizt (1m ²)	50
Durchlauferhitzerdampf- / heißwasser-beheizt (0,6 m ²)	52
Kondensator - Verkleidungen	54
Kondensator	56
Wrasenabzug - Haube	58
Wrasenabzug - Ventilator	60
Trockenzone D2	62
Trockenzone D2A + D2T	64
Trockenzone - Verrohrung D2 + D2A + D2T	68
Gebläse	70
Trockenzone - Haube D2 + D2A + D2T	72
Trockenzone TB2	74
Gebläse TB2	76
Trockenzone - Haube TB2	78
Trockenzone TB4	80
Gebläse TB4	82
Trockenzone - Haube TB4	84
Schaltkästen	86
Auslaufzone	88
Auslaufzone - Bandantrieb I	90
Auslaufzone - Bandantrieb II	92

Sommaire

Zone de chargement No. 0 +1 + 2	4
Zone de chargement No. 3	8
Zone de chargement No. 0 - 3	10
Zone de chargement - capot	12
Module 1 400 mm	14
Module 900 mm	18
Chauffage de bac et interrupteur à flotteur I	22
Chauffage de bac et interrupteur à flotteur II	24
Chauffage de bac (eau chaude et vapeur)	26
Pompe de lavage I	28
Pompe de lavage II	30
Système de lavage et pré-lavage	32
Vidange	36
Zone de rinçage	38
Double rinçage	42
Chaudière électrique	46
Chaudière chauffage vapeur / eau chaude (1m ²)	50
Chaudière chauffage vapeur / eau chaude (0,6 m ²)	52
Condenseur - habillage	54
Condenseur	56
Extraction des buées - capot	58
Extraction des buées - ventilateur	60
Zone de séchage D2	62
Zone de séchage D2A + D2T	64
Zone de séchage - tuyauterie D2 + D2A + D2T	68
Soufflage	70
Zone de séchage - capot D2 + D2A + D2T	72
Zone de séchage TB2	74
Soufflage TB2	76
Zone de séchage - capot TB2	78
Zone de séchage TB4	80
Soufflage TB4	82
Zone de séchage - capot TB4	84
Panneaux de commande	86
Zones de déchargement	88
Zones de déchargement - entrainement du convoyeur I	90
Zones de déchargement - entrainement du convoyeur II	92

Inhoud

Toevoersectie No. 0 +1 + 2	4
Toevoersectie No. 3	8
Toevoersectie No. 0 - 3	10
Toevoersectie - Kap	12
Modul 1 400 mm	14
Modul 900 mm	18
Tankverwarming und zwem-schakelaar I	22
Tankverwarming und zwem-schakelaar II	24
Tankverwarming (heet water en stoom)	26
Was pomp I	28
Was pomp II	30
Was en voorwas system	32
Afvoer	36
Naspoelzone	38
Duo naspoeling	42
Booster elektrisch	46
Booster stoom / heet water verwarming (1m ²)	50
Booster stoom / heet water verwarming (0,6 m ²)	52
Kondensator - bekledingen	54
Kondensator	56
Wasemafzuiging - behuizing	58
Wasemafzuiging - ventilator	60
Droogzone D2	62
Droogzone D2A + D2T	64
Droogzone - pijpleiding D2 + D2A + D2T	68
Ventilator	70
Droogzone - behuizing D2 + D2A + D2T	72
Droogzone TB2	74
Ventilator TB2	76
Droogzone - behuizing TB2	78
Droogzone TB4	80
Ventilator TB4	82
Droogzone - behuizing TB4	84
Schakelkasten	86
Afvoersectie	88
Afvoersectie - transportbandaandrijving I	90
Afvoersectie - transportbandaandrijving II	92

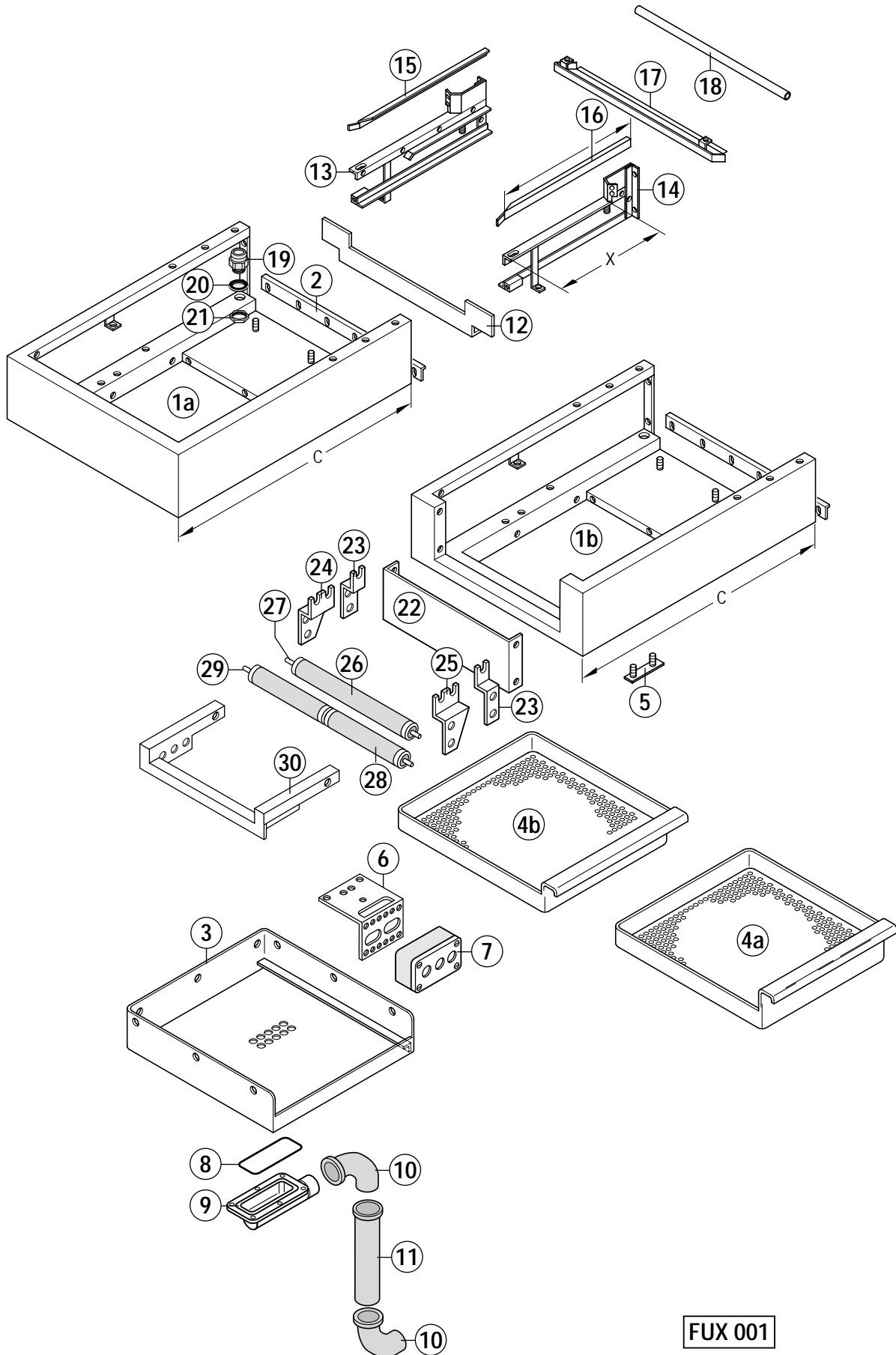

Pos.	L/R G/D	R/L D/G	Specifications / Spécifications / Angaben / Opgaven
1a	229 230-1	=	A = 612 mm / C = 800 mm
	375 840	=	A = 965 mm / C = 800 mm
	229 230-2	=	A = 612 mm / C = 1 085 mm
	229 918	=	A = 965 mm / C = 1 085 mm
1b	694 102	=	A = 612 mm / C = 450 mm
	698 096-1	=	A = 965 mm / C = 450 mm
	731 564-1	=	A = 612 mm / C = 800 mm
	698 096-2	=	A = 965 mm / C = 800 mm
	698 618-3	=	A = 612 mm / C = 1 085 mm
	698 618-1	=	A = 965 mm / C = 1 085 mm
2	229 185-1	=	A = 612 mm
	229 938	=	A = 965 mm
3	230 472	=	A = 612 mm
	300 658	=	A = 965 mm
	694 104	=	A = 612 mm (only with entry section 0 / nur mit Zulaufstrecke 0 / seulement avec zone de chargement 0 / maar met toevoersectie 0)
	302 642-7	=	A = 965 mm (only with entry section 0 / nur mit Zulaufstrecke 0 / seulement avec zone de chargement 0 / maar met toevoersectie 0)
4a	229 065	=	A = 612 mm
	375 463	=	A = 965 mm
	694 106	=	A = 612 mm (only with entry section 0 / nur mit Zulaufstrecke 0 / seulement avec zone de chargement 0 / maar met toevoersectie 0)
	302 640-7	=	A = 965 mm (only with entry section 0 / nur mit Zulaufstrecke 0 / seulement avec zone de chargement 0 / maar met toevoersectie 0)
4b	375 467-1	=	
5	229 264	=	
6	897 254-1	=	
7	887 017-2	=	
8	276 903-35	=	
9	325 529-1	=	
10	230 080-1	=	
11	600 571	=	
12	229 672	=	A = 612 mm
	229 937	=	A = 965 mm
13	694 115	694 116	X = 190 mm
	229 316-1	229 317-1	X = 140 mm
	229 316-2	229 317-2	X = 426 mm
14	694 116	694 115	X = 190 mm
	229 317-1	229 316-1	X = 140 mm
	229 317-2	229 316-2	X = 426 mm
15	229 673-1	229 674-1	X = 490 mm
	229 673-2	229 674-2	X = 776 mm
16	229 674-1	229 673-1	X = 490 mm
	229 674-2	229 673-2	X = 776 mm
17	229 668	=	A = 612 mm
	229 986	=	A = 965 mm
18	229 263-3	=	A = 612 mm
	229 263-8	=	A = 965 mm



A conveyor width
largeur du convoyeur
Bandbreite
bandbreedte

B usable height
hauteur de passage
Durchlaufhöhe
doorvoerhoogte

C Entry length
Longueur d'entrée
Zulauflänge
Toevoerlengte

Pos.	L/R G/D	R/L D/G	Specifications / Spécifications / Angaben / Opgaven
19	695 661-3	=	
20	172 986-3	=	
21	695 664-3	=	
22	736 776-1	=	A = 612 mm
	?	=	A = 965 mm
23	782 462-3	=	
24	782 462-2	782 462-1	
25	782 462-1	782 462-2	
26	303 519-2	=	A = 612 mm
27	303 589-1	=	A = 612 mm
28	303 519-6	=	A = 965 mm
29	303 589-4	=	A = 965 mm
30	303 591	=	A = 612 mm
	696 447-2	=	A = 965 mm

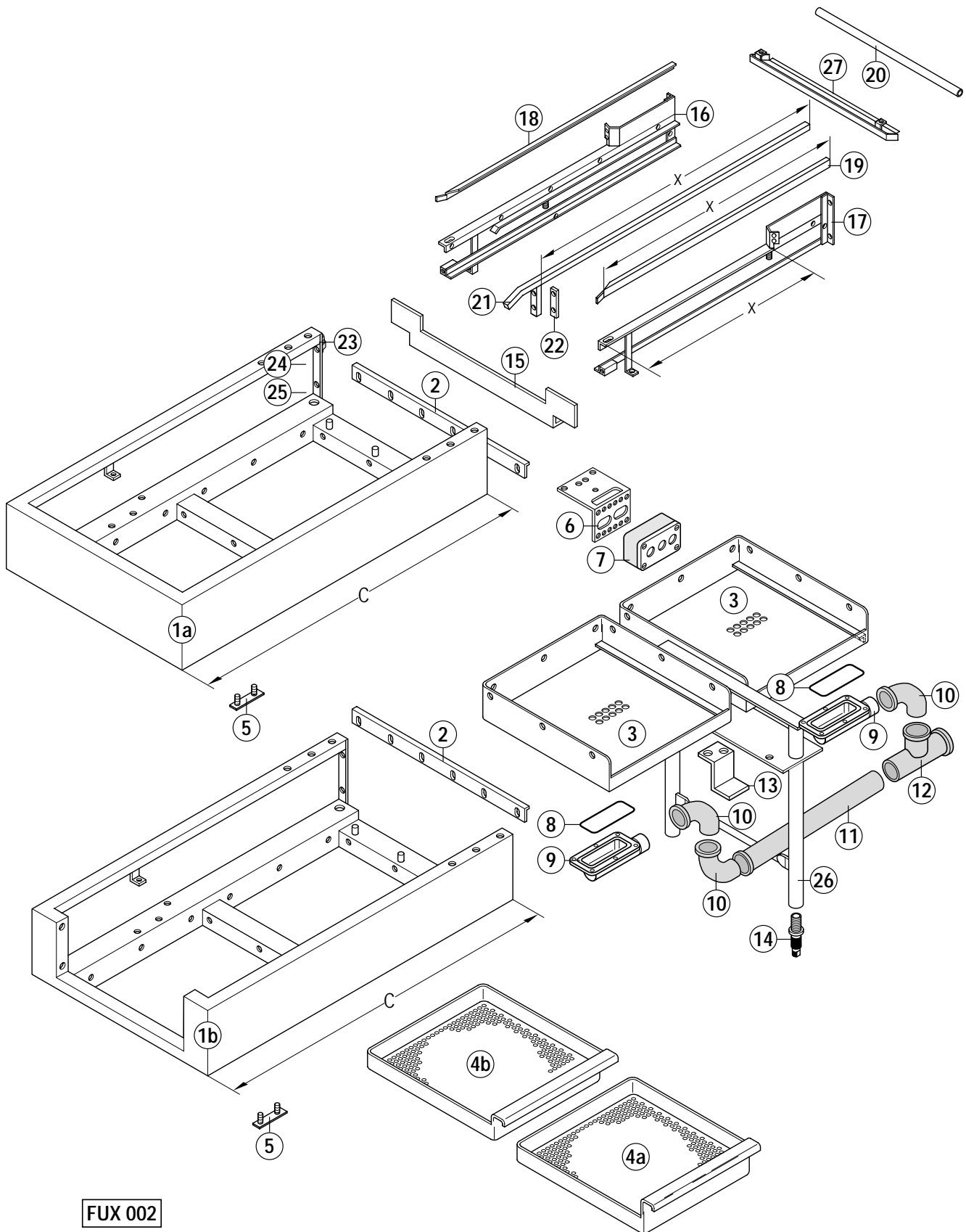
**FUX 002**



A conveyor width
largeur du convoyeur
Bandbreite
bandbreedte

B usable height
hauteur de passage
Durchlaufhöhe
doorvoerhoogte

C Entry length
Longueur d'entrée
Zulauflänge
Toevoerlengte

Pos.	L/R G/D	R/L D/G	Specifications / Spécifications / Angaben / Opgaven
1a	229 633-1	=	A = 612 mm / C = 1 400 mm
	230 522	=	A = 965 mm / C = 1 400 mm
1b	731 562-1	=	A = 612 mm / C = 1 400 mm
	782 284-1	=	A = 965 mm / C = 1 400 mm
2	229 185-1	=	A = 612 mm
	229 938	=	A = 965 mm
3	230 472	=	A = 612 mm
	300 658	=	A = 965 mm
4a	229 065	=	A = 612 mm
	375 463	=	A = 965 mm
4b	375 467-1	=	
5	229 264	=	
6	897 254-1	=	
7	887 017-2	=	
8	276 903-35	=	
9	325 529-1	=	
10	230 080-1	=	
11	600 571	=	
12	230 079-1	=	
13	696 980-2	=	
14	166 066-3	=	
15	229 672	=	A = 612 mm
	229 937	=	A = 965 mm
16	229 316-4	229 317-4	X = 741 mm
17	229 317-4	229 316-4	X = 741 mm
18	229 673-3	229 674-3	X = 1 090 mm
19	229 674-3	229 673-3	X = 1 090 mm
20	229 263-3	=	A = 612 mm
	229 263-8	=	A = 965 mm
21	229 640-3	=	X = 1 015 mm
22	229 638	=	
23	695 661-3	=	
24	172 986-3	=	
25	695 664-3	=	
26	296 642	=	A = 612 mm
	300 665	=	A = 965 mm
27	229 668	=	A = 612 mm
	229 986	=	A = 965 mm

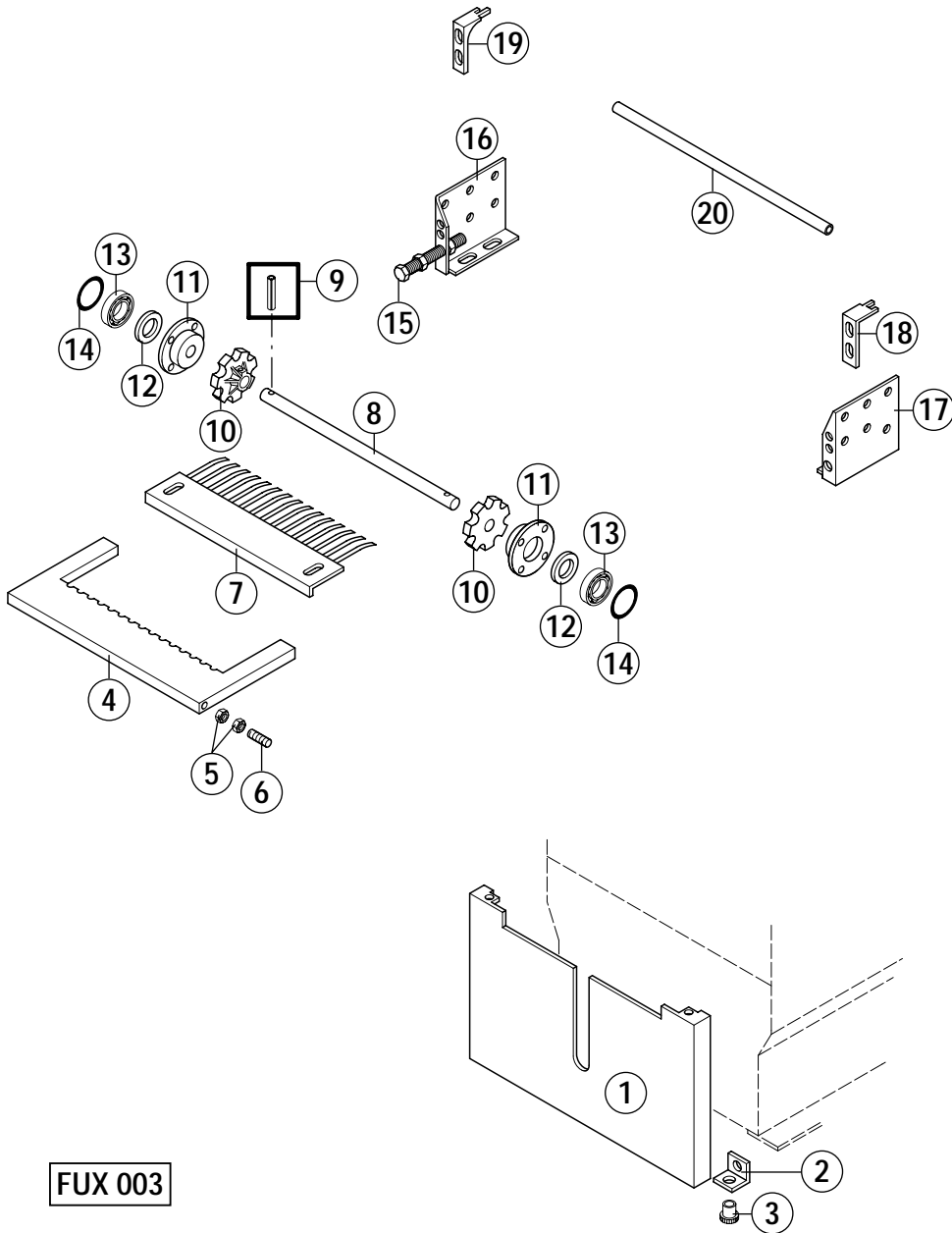



A conveyor width
largeur du convoyeur
Bandbreite
bandbreedte

B usable height
hauteur de passage
Durchlaufhöhe
doorvoerhoogte

C Entry length
Longueur d'entrée
Zulauflänge
Toevoerlengte

Pos.	L/R G/D	R/L D/G	Specifications / Spécifications / Angaben / Opgaven
1	229 494	=	A = 612 mm
	229 936	=	A = 965 mm
2	229 495	=	
3	229 525	=	
4	229 262	=	A = 612 mm
	229 978	=	A = 965 mm
5	602 491	=	
6	503 548	=	
7	229 302	=	A = 612 mm
	229 984	=	A = 965 mm
8	229 378	=	A = 612 mm
	229 921	=	A = 965 mm
9	602 849	=	
10	229 240	=	
	303 598	=	SST / CrNi / Inox
11	229 263	=	
12	229 552-1	=	
13	602 748	=	
14	229 239	=	
15	603 546	=	
16	229 297	=	
17	229 298	=	
18	300 536	=	
19	300 535	=	
20	229 263-2	=	A = 612 mm
	229 263-4	=	A = 965 mm

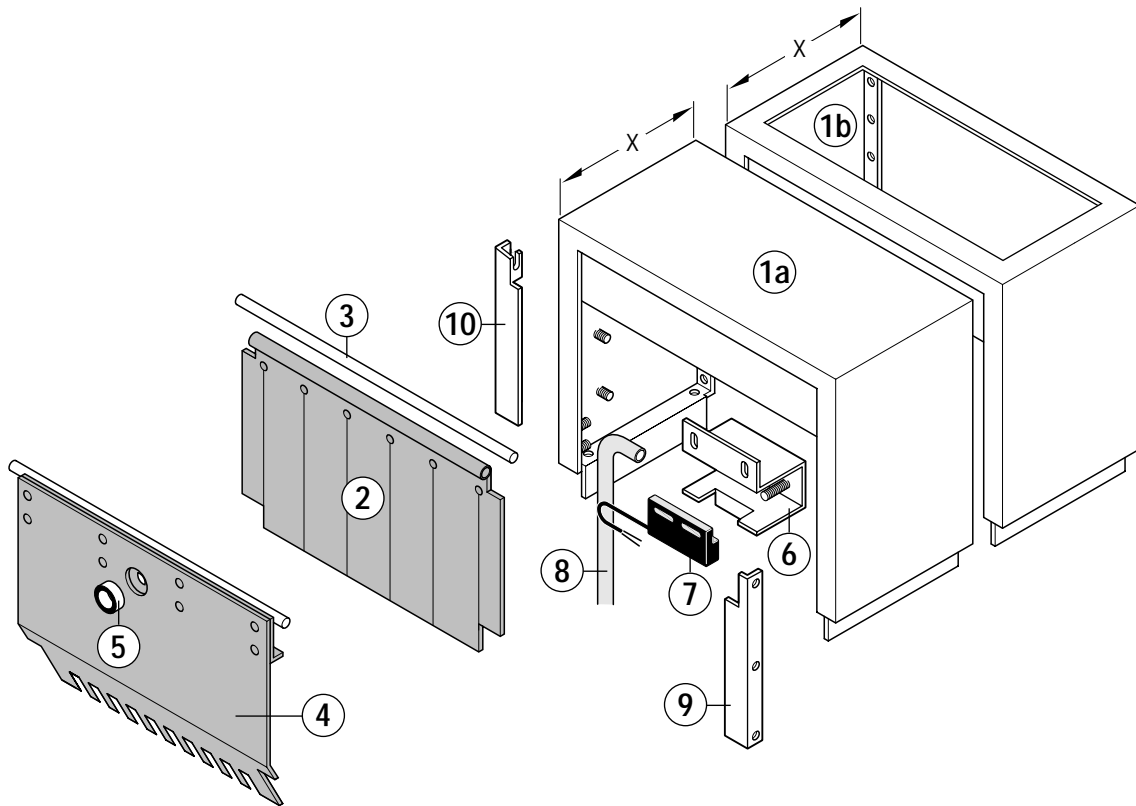
**FUX 004**

Pos.	L/R G/D	R/L D/G	Specifications / Spécifications / Angaben / Opgaven
1a	229 449	=	A = 612 mm / B = 440 mm X = 350 mm
	298 682-31	=	A = 612 mm / B = 683 mm X = 350 mm
	229 916	=	A = 965 mm / B = 440 mm X = 350 mm
	298 682-21	=	A = 965 mm / B = 683 mm X = 350 mm
	300 524	=	A = 612 mm / B = 440 mm X = 600 mm
	229 772	=	A = 612 mm / B = 683 mm X = 600 mm
	298 682-35	=	A = 965 mm / B = 440 mm X = 600 mm
	230 525	=	A = 965 mm / B = 683 mm X = 600 mm
1b	303 865	=	A = 612 mm / B = 440 mm X = 350 mm
	298 682-24	=	A = 612 mm / B = 683 mm X = 350 mm
	303 864	=	A = 965 mm / B = 440 mm X = 350 mm
	298 682-33	=	A = 965 mm / B = 683 mm X = 350 mm
	380 518	=	A = 612 mm / B = 440 mm X = 600 mm
	298 682-26	=	A = 612 mm / B = 683 mm X = 600 mm
	298 682-23	=	A = 965 mm / B = 440 mm X = 600 mm
	298 682-25	=	A = 965 mm / B = 683 mm X = 600 mm
2	229 436-1	=	A = 612 mm / B = 440 mm
	229 436-3	=	A = 612 mm / B = 683 mm
	229 436-4	=	A = 965 mm / B = 440 mm
	229 436-6	=	A = 965 mm / B = 683 mm
3	229 214	=	A = 612 mm
	229 924	=	A = 965 mm
4	229 614	=	A = 612 mm / B = 440 mm
	229 788-1	=	A = 612 mm / B = 683 mm
	229 932	=	A = 965 mm / B = 440 mm
	372 740-18	=	A = 965 mm / B = 683 mm
5	166 964	=	DN 40/50
6	897 220-1	=	
7	229 517-2	=	see wiring diagramme / voir schéma de câblage / siehe Schaltplan / zie elektrisch schema
8	165 168-17	=	
9	229 598	229 599	A = 612 mm
	229 773	229 774	A = 965 mm
10	229 599	229 598	A = 612 mm
	229 774	229 773	A = 965 mm

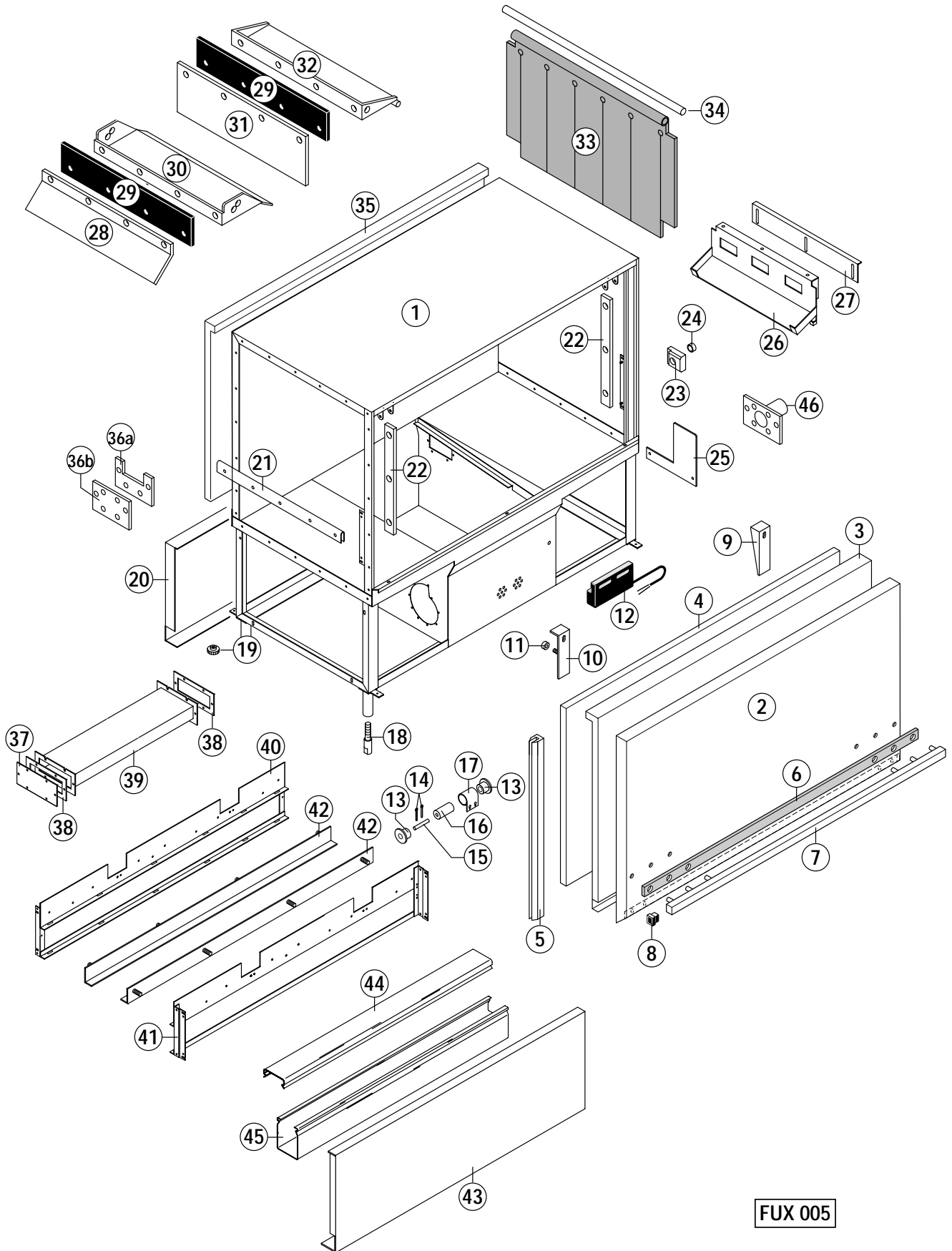

FUX 005

Pos.	L/R G/D	R/L D/G	Specifications / Spécifications / Angaben / Opgaven
1	375 209-3	=	A = 612 mm / B = 440 mm
	780 688-4	=	A = 612 mm / B = 683 mm
	780 688-1	=	A = 965 mm / B = 440 mm
	780 688-2	=	A = 965 mm / B = 683 mm
2	304 735-57	=	B = 440 mm
	304 735-55	=	B = 683 mm
3	374 712-9	=	B = 440 mm
	374 712-26	=	B = 683 mm
4	304 735-57	=	B = 440 mm
	304 735-55	=	B = 683 mm
5	302 207-4	=	B = 440 mm
	302 207-6	=	B = 683 mm
6	374 898-2	=	
7	304 755-4	=	
8	229 532	=	
9	691 861-1	=	2x
10	303 516	=	
11	166 964	=	
12	229 517-2	=	see wiring diagramme / voir schéma de câblage / siehe Schaltplan / zie elektrisch schema
13	784 934-1	=	
14	602 886	=	
15	602 846	=	
16	173 481	=	
17	230 072	=	B = 440 mm 1x (without insulation / sans isolation / ohne Isolierung / zonder isolatie)
	229 277	=	B = 440 mm 2x (without insulation / sans isolation / ohne Isolierung / zonder isolatie)
	229 473	=	B = 683 mm 3x (without insulation / sans isolation / ohne Isolierung / zonder isolatie)
	229 732	=	B = 440 mm 3x (with insulation / avec isolation / mit Isolierung / met isolatie)
	229 277	=	B = 440 mm 1x (with insulation / avec isolation / mit Isolierung / met isolatie)
	229 473	=	B = 683 mm 4x (with insulation / avec isolation / mit Isolierung / met isolatie)
18	166 066-3	=	
19	229 525	=	
20	375 472-5	=	
21	229 401	=	A = 612 mm
	229 401	=	A = 965 mm
22	780 785-3	=	B = 683 mm
23	229 560	=	
24	229 570	=	
25	231 539	=	
26	230 061-1	=	A = 612 mm
	230 554	=	A = 965 mm
27	698 054-3	=	A = 612 mm
	698 054-4	=	A = 965 mm
28	230 749	=	A = 612 mm
	300 549	=	A = 965 mm
29	230 750	=	A = 612 mm
	300 574	=	A = 965 mm
30	230 748	=	A = 612 mm
	375 670	=	A = 965 mm
31	229 559	=	A = 612 mm



A conveyor width
largeur du convoyeur
Bandbreite
bandbreedte

B usable height
hauteur de passage
Durchlaufhöhe
doorvoerhoogte

C Entry lenght
Longueur d'entrée
Zulauflänge
Toevoerlengte

Pos.	L/R G/D	R/L D/G	Specifications / Spécifications / Angaben / Opgaven
	300 548	=	A = 965 mm
32	229 340	=	A = 612 mm
	698 632-2	=	A = 965 mm
33	229 436-1	=	A = 612 mm / B = 440 mm
	229 436-3	=	A = 612 mm / B = 683 mm
	229 436-4	=	A = 965 mm / B = 440 mm
	229 436-6	=	A = 965 mm / B = 683 mm
34	229 214	=	A = 612 mm
	229 924-1	=	A = 965 mm
35	374 714-8	=	B = 440 mm
	374 714-23	=	B = 683 mm
36a	229 162-3	=	
36b	229 162-1	=	
37	229 166-1	=	
38	229 161	=	
39	300 272	=	
40	374 801-20	=	
41	374 802-8	=	
42	375 227-1	=	
43	374 472-5	=	
44	374 804-4	=	
45	374 803-4	=	
46	733 912-1	=	

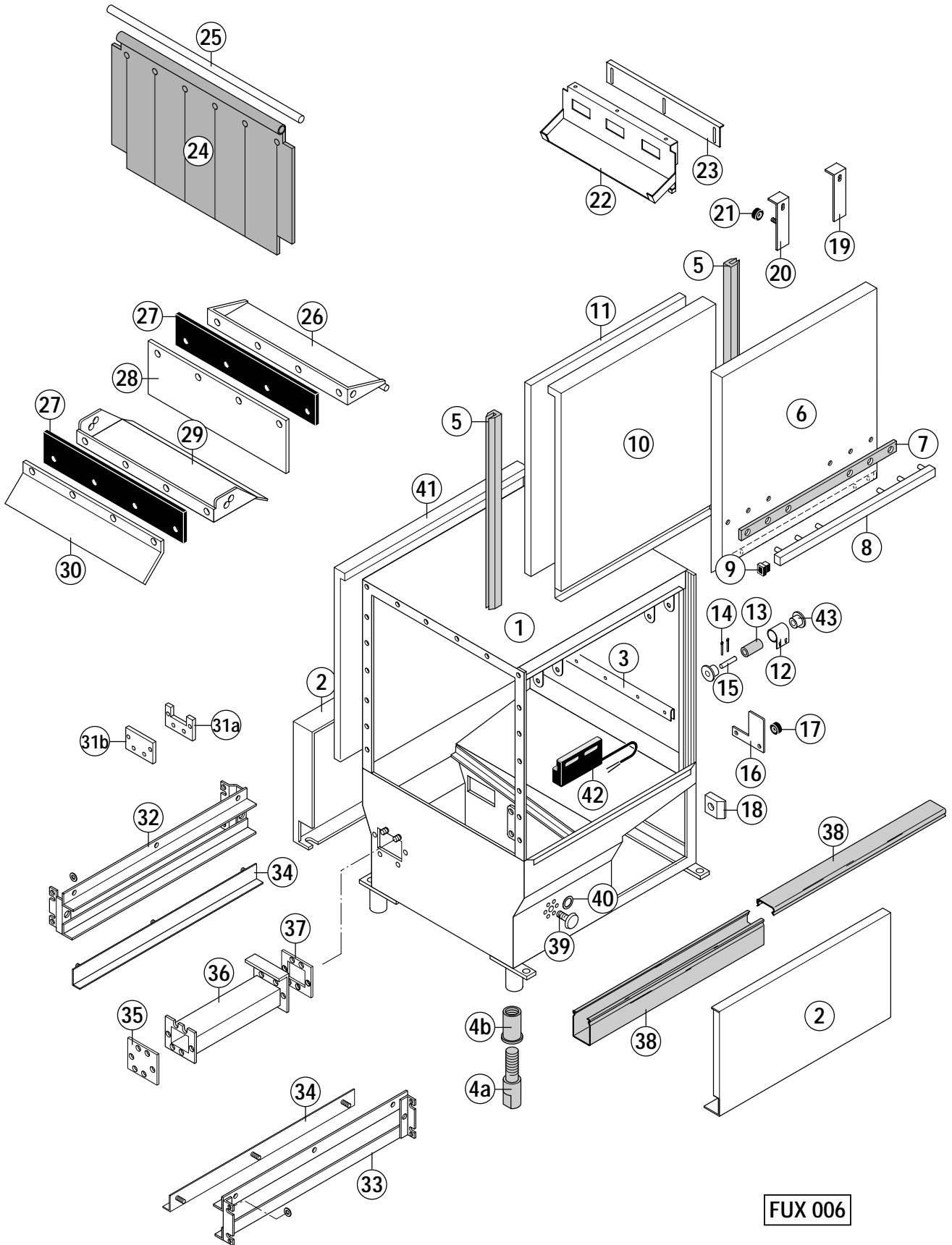

FUX 006



A conveyor width
largeur du convoyeur
Bandbreite
bandbreedte

B usable height
hauteur de passage
Durchlaufhöhe
doorvoerhoogte

C Entry length
Longueur d'entrée
Zulauflänge
Toevoerlengte

Pos.	L/R G/D	R/L D/G	Specifications / Spécifications / Angaben / Opgaven
1	229 392	=	A = 612 mm / B = 440 mm
	229 941	=	A = 612 mm / B = 683 mm
	229 783	=	A = 965 mm / B = 440 mm
	230 531	=	A = 965 mm / B = 683 mm
2	229 205-1	=	
3	229 401	=	A = 612 mm
	230 310	=	A = 965 mm
4a	166 066-3	=	
4b	375 122-1	=	
5	302 207-4	=	B = 440 mm
	302 207-6	=	B = 683 mm
6	229 132	=	B = 440 mm
	229 816	=	B = 683 mm
7	229 531	=	
8	229 501	=	
9	229 532	=	
10	374 712-2	=	B = 440 mm
	374 712-3	=	B = 683 mm
11	229 132	=	B = 440 mm
	229 816	=	B = 683 mm
12	229 277	=	B = 440 mm without insulation / sans isolement / ohne Isolierung / zonder isolatie
	229 473	=	B = 683 mm without insulation / sans isolement / ohne Isolierung / zonder isolatie
	229 732	=	B = 440 mm with insulation / avec isolement / mit Isolierung / met isolatie
	229 473	=	B = 683 mm with insulation / avec isolement / mit Isolierung / met isolatie
13	173 481	=	
14	603 274	=	
15	602 839	=	
16	231 539	=	
17	229 570	=	
18	225 560	=	
19	303 517	=	
20	303 516	=	
21	774 714-1	=	
22	230 061-1	=	B = 440 mm
	230 554	=	B = 683 mm
23	229 646	=	B = 440 mm
	230 438	=	B = 683 mm
24	229 436-1	=	A = 612 mm / B = 440 mm
	229 436-3	=	A = 612 mm / B = 683 mm
	229 436-4	=	A = 965 mm / B = 440 mm
	229 436-6	=	A = 965 mm / B = 683 mm
25	229 214	=	B = 440 mm
	229 924	=	B = 683 mm
26	229 340	=	B = 440 mm
	698 632-2	=	B = 683 mm
27	230 750	=	B = 440 mm
	300 547	=	B = 683 mm
28	229 559	=	B = 440 mm
	300 548	=	B = 683 mm



A conveyor width
 largeur du convoyeur
 Bandbreite
 bandbreedte

B usable height
 hauteur de passage
 Durchlaufhöhe
 doorvoerhoogte

C Entry length
 Longueur d'entrée
 Zulauflänge
 Toevoerlengte

Pos.	L/R G/D	R/L D/G	Specifications / Spécifications / Angaben / Opgaven
29	230 748	=	B = 440 mm
	375 670	=	B = 683 mm
30	230 749	=	B = 440 mm
	300 549	=	B = 683 mm
31a	229 162-3	=	
31b	229 162-1	=	
32	229 216-1	229 215-1	
33	229 215-1	229 216-1	
34	230 539	=	
35	229 166-1	=	
36	229 160	=	
37	229 161	=	
38	229 553-1	=	
39	229 585	=	
40	67 500-118	=	
41	230 508	=	B = 440 mm
	229 901	=	B = 683 mm
42	229 517-2	=	see wiring diagramme / voir schéma de câblage / siehe Schaltplan / zie elektrisch schema
43	784 934-1	=	

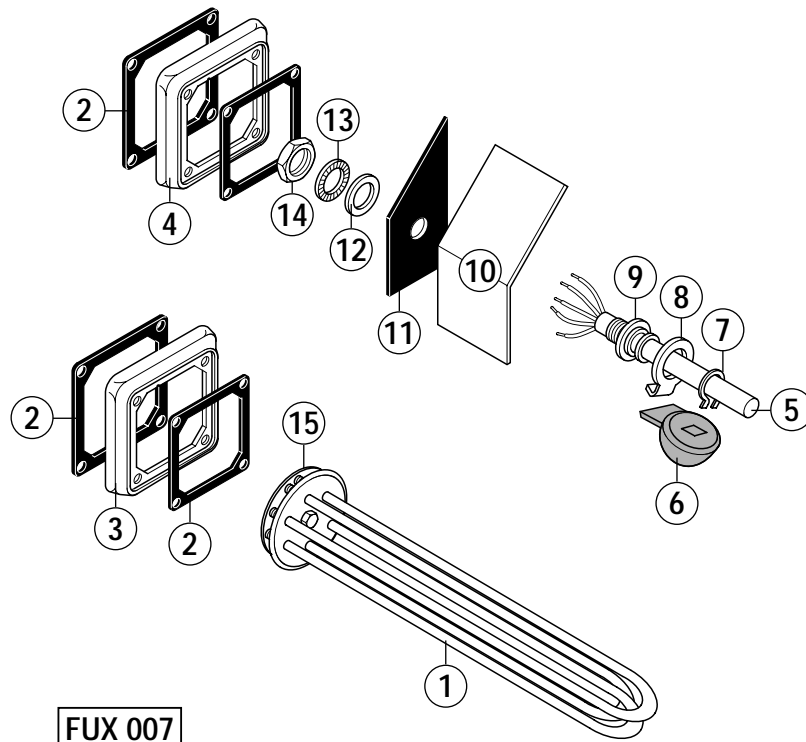



A conveyor width
largeur du convoyeur
Bandbreite
bandbreedte

B usable height
hauteur de passage
Durchlaufhöhe
doorvoerhoogte

C Entry length
Longueur d'entrée
Zulauflänge
Toevoerlengte

Pos.	L/R G/D	R/L D/G	Specifications / Spécifications / Angaben / Opgaven
1	229 148-1	=	9 kW see wiring diagramme / voir schéma de câblage / siehe Schaltplan / zie elektrisch schema
	229 148-3	=	12 kW see wiring diagramme / voir schéma de câblage / siehe Schaltplan / zie elektrisch schema
2	229 516	=	
3	229 513-6	=	
	229 513-7	=	only prewash / seulement pré lavage / nur Vorabräumung / maar voorwasing
4	229 231-5	=	
5	229 519	=	
6	122 674	=	
7	602 302	=	
8	112 467	=	
9	168 611-21	=	
10	229 190	=	
11	300 600	=	
12	602 292	=	
13	602 316	=	
14	602 476	=	
15	67 500-118	=	

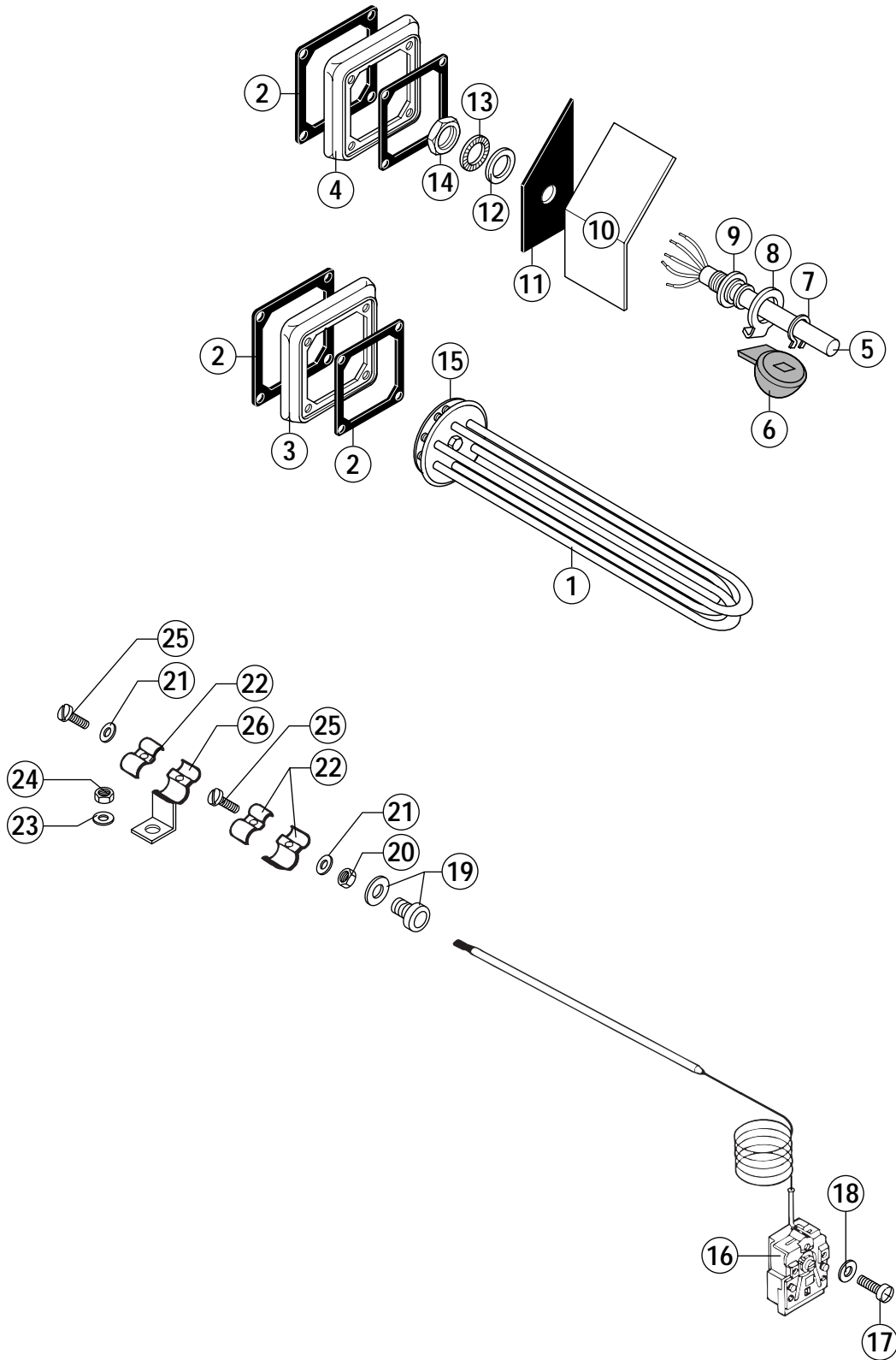



A conveyor width
largeur du convoyeur
Bandbreite
bandbreedte

B usable height
hauteur de passage
Durchlaufhöhe
doorvoerhoogte

C Entry length
Longueur d'entrée
Zulauflänge
Toevoerlengte

Pos.	L/R G/D	R/L D/G	Specifications / Spécifications / Angaben / Opgaven
1	229 148-62	=	9 kW see wiring diagramme / voir schéma de câblage / siehe Schaltplan / zie elektrisch schema
	229 148-60	=	12 kW see wiring diagramme / voir schéma de câblage / siehe Schaltplan / zie elektrisch schema
2	229 516	=	
3	229 513-6	=	
	229 513-7	=	only prewash / seulement pré lavage / nur Vorabräumung / maar voorwasing
4	229 231-5	=	
5	229 519	=	
6	122 674	=	
7	602 302	=	
8	112 467	=	
9	168 611-21	=	
10	229 190	=	
11	300 600	=	
12	602 292	=	
13	602 316	=	
14	602 476	=	
15	67 500-118	=	
16	887 020-1	=	see wiring diagramme / voir schéma de câblage / siehe Schaltplan / zie elektrisch schema
17	602 687	=	M4 x 6
18	602 308	=	B4
19	227 024	=	
20	602 488	=	M3
21	602 294	=	B3
22	324 157	=	
23	602 308	=	B4
24	602 489	=	M4
25	602 646	=	M3 x 10
26	324 156	=	

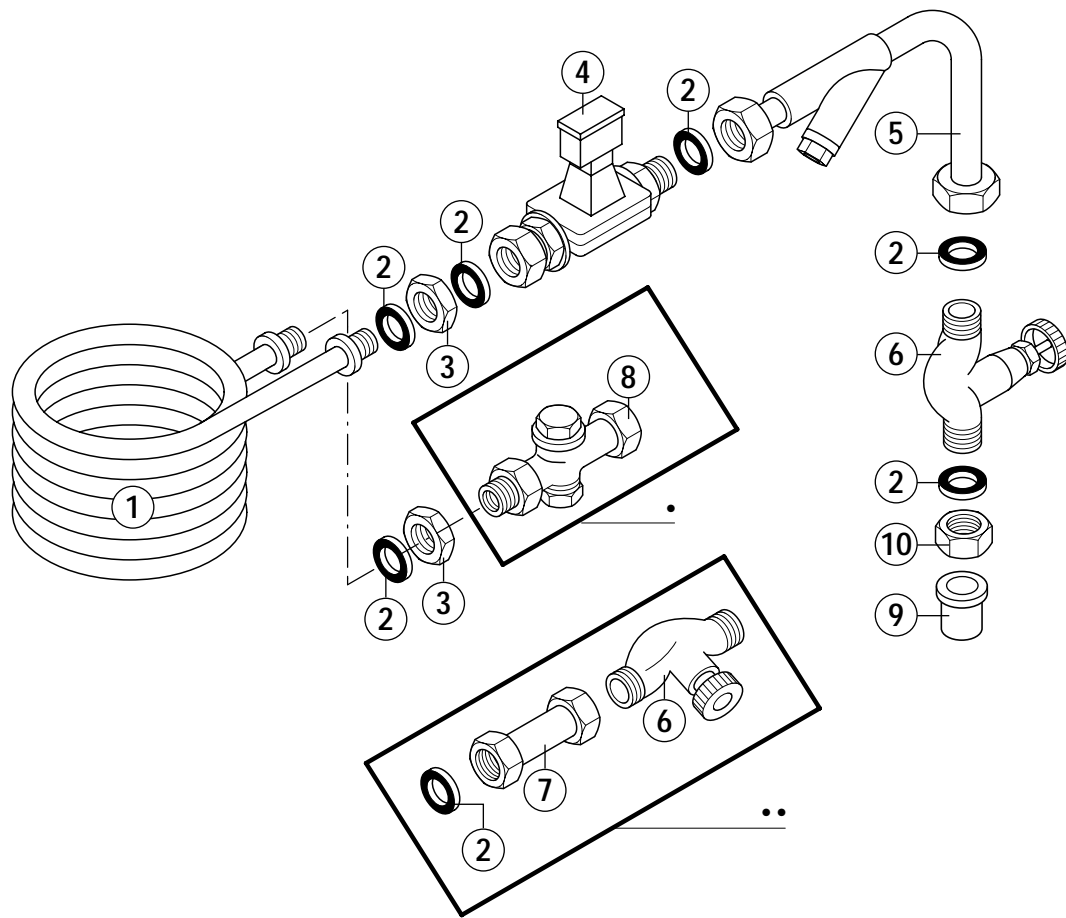

FUX 008

- steam
vapeur
Dampf
stoom
- hot water
eau chaude
Heißwasser
heet water



A conveyor width
largeur du convoyeur
Bandbreite
bandbreedte

B usable height
hauteur de passage
Durchlaufhöhe
doorvoerhoogte

C Entry length
Longueur d'entrée
Zulauflänge
Toevoerlengte

Pos.	L/R G/D	R/L D/G	Specifications / Spécifications / Angaben / Opgaven
1	229 661	=	
2	302 574-1	=	
3	172 739-3	=	
4	869 493-1	=	see wiring diagramme / voir schéma de câblage / siehe Schaltplan / zie elektrisch schema
5	229 664	=	
6	165 828-2	=	
7	229 665	=	
8	168 704	=	0,1 - 3,5 bar
	302 507	=	3,5 - 21 bar
9	168 608-3	=	
10	168 610-1	=	

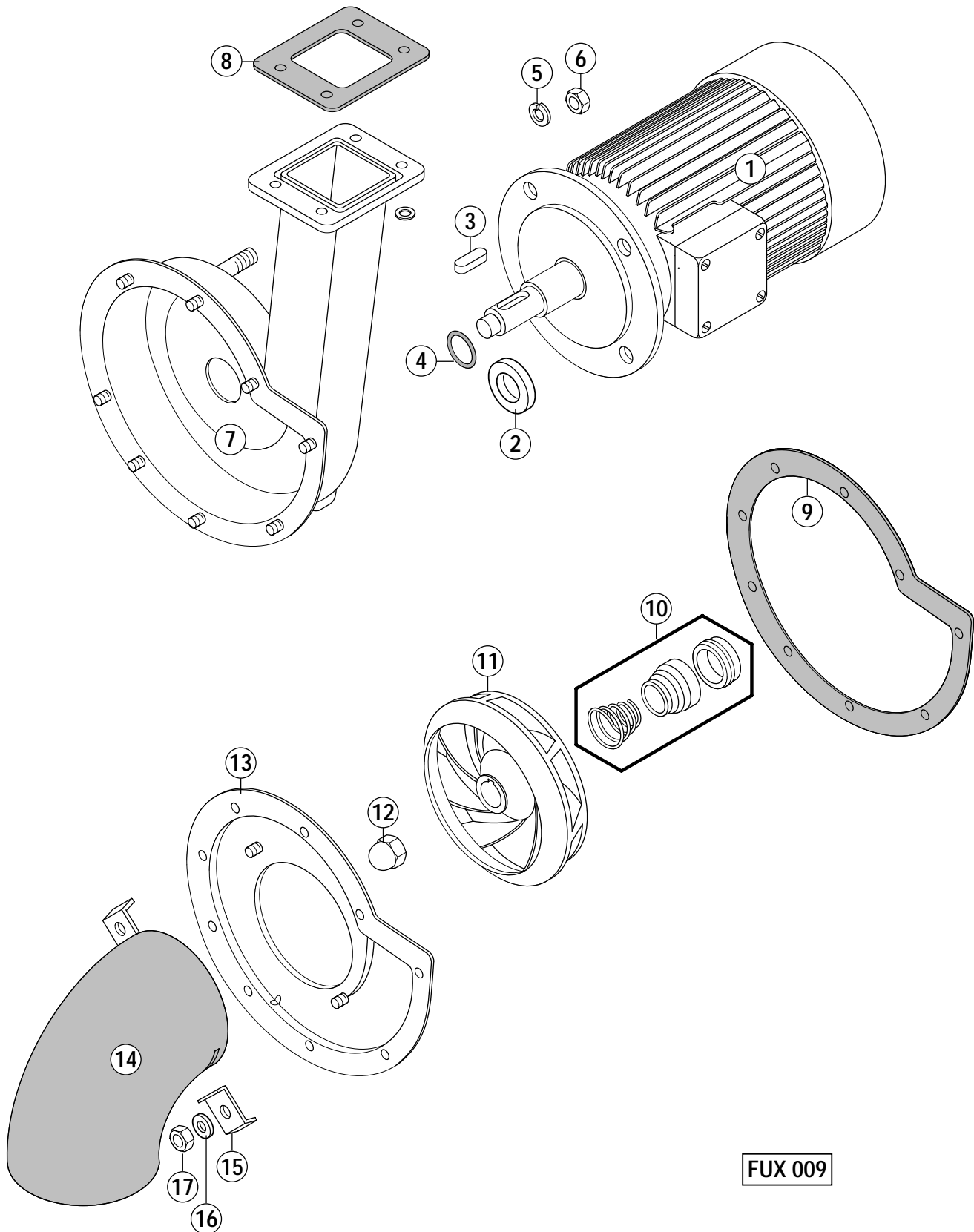
**FUX 009**



A conveyor width
 largeur du convoyeur
 Bandbreite
 bandbreedte

B usable height
 hauteur de passage
 Durchlaufhöhe
 doorvoerhoogte

C Entry length
 Longueur d'entrée
 Zulauflänge
 Toevoerlengte

Pos.	L/R G/D	R/L D/G	Specifications / Spécifications / Angaben / Opgaven
1	229 136-25	=	4 kW see wiring diagramme / voir schéma de câblage / siehe Schaltplan / zie elektrisch schema
	229 136-17	=	2,2 kW see wiring diagramme / voir schéma de câblage / siehe Schaltplan / zie elektrisch schema
2	696 440-1	=	
3	602 344	=	
4	67 500-6	=	
5	602 295	=	Ø 10
6	602 493	=	M 10
7	229 395	=	2,2 / 0,5 kW
	230 240	=	4 kW
8	296 709	=	
9	229 402	=	
10	104 329	=	
11	229 137-1	=	2,2 kW (50 Hz)
	229 137-2	=	2,2 kW (60 Hz)
	229 575-1	=	4 kW (50 Hz)
	229 575-2	=	4 kW (60 Hz)
12	602 504	=	
13	229 616	=	
14	229 434	=	
15	229 416	=	
16	602 286	=	Ø 6
17	602 502	=	M 6
18	696 440-1	=	

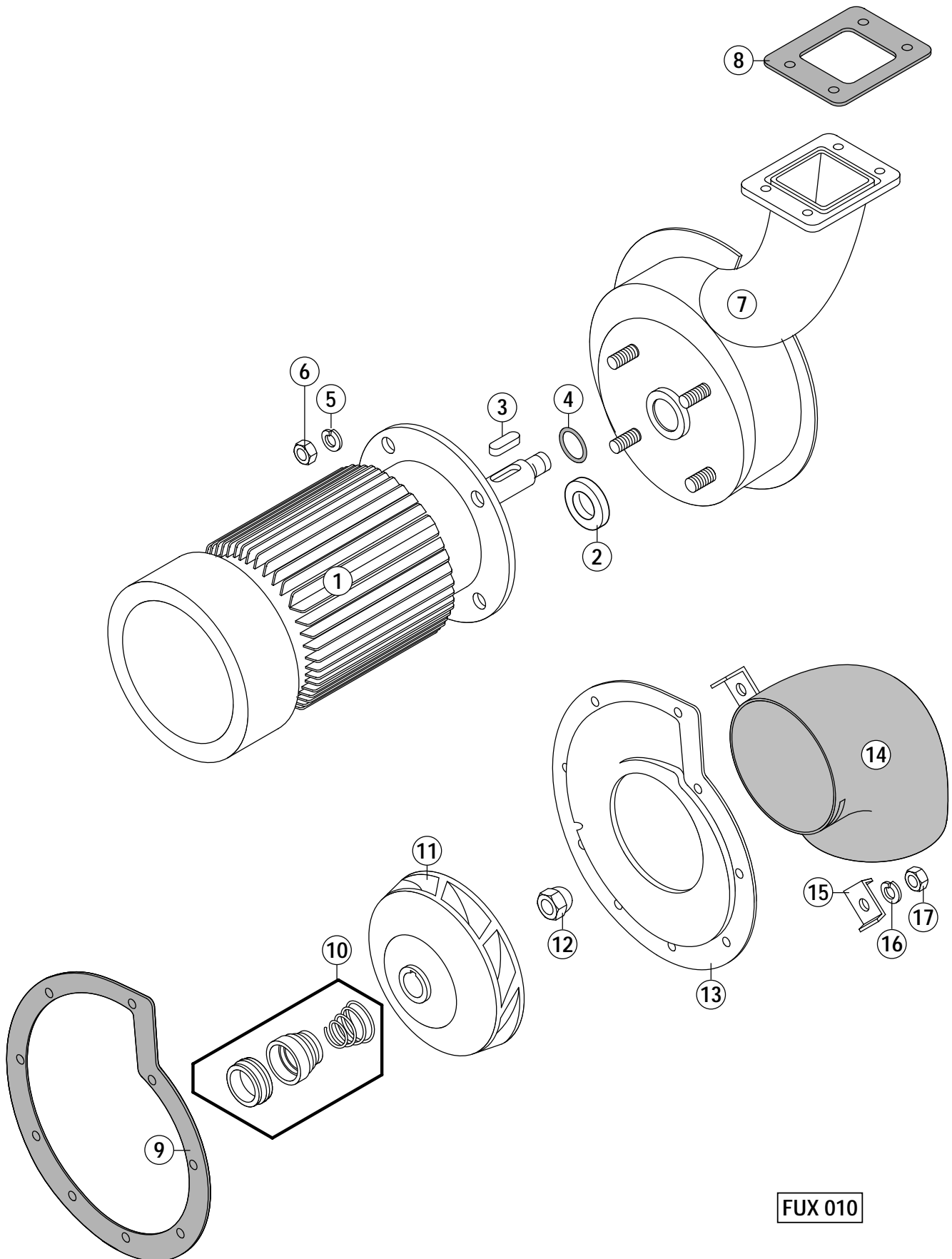
**FUX 010**



A conveyor width
 largeur du convoyeur
 Bandbreite
 bandbreedte

B usable height
 hauteur de passage
 Durchlaufhöhe
 doorvoerhoogte

C Entry length
 Longueur d'entrée
 Zulauflänge
 Toevoerlengte

Pos.	L/R G/D	R/L D/G	Specifications / Spécifications / Angaben / Opgaven
1	229 136-25	=	4 kW see wiring diagramme / voir schéma de câblage / siehe Schaltplan / zie elektrisch schema
	229 136-17	=	2,2 kW see wiring diagramme / voir schéma de câblage / siehe Schaltplan / zie elektrisch schema
2	696 440-1	=	
3	602 344	=	
4	67 500-6	=	
5	602 295	=	Ø 10
6	602 493	=	M 10
7	300 725	=	2,2 / 0,5 kW
	300 905	=	4 kW
8	296 709	=	
9	229 402	=	
10	104 329	=	
11	229 137-1	=	2,2 kW (50 Hz)
	229 137-2	=	2,2 kW (60 Hz)
	229 575-1	=	4 kW (50 Hz)
	229 575-2	=	4 kW (60 Hz)
12	602 504	=	
13	229 616	=	
14	229 434	=	
15	229 416	=	
16	602 286	=	Ø 6
17	602 502	=	M 6

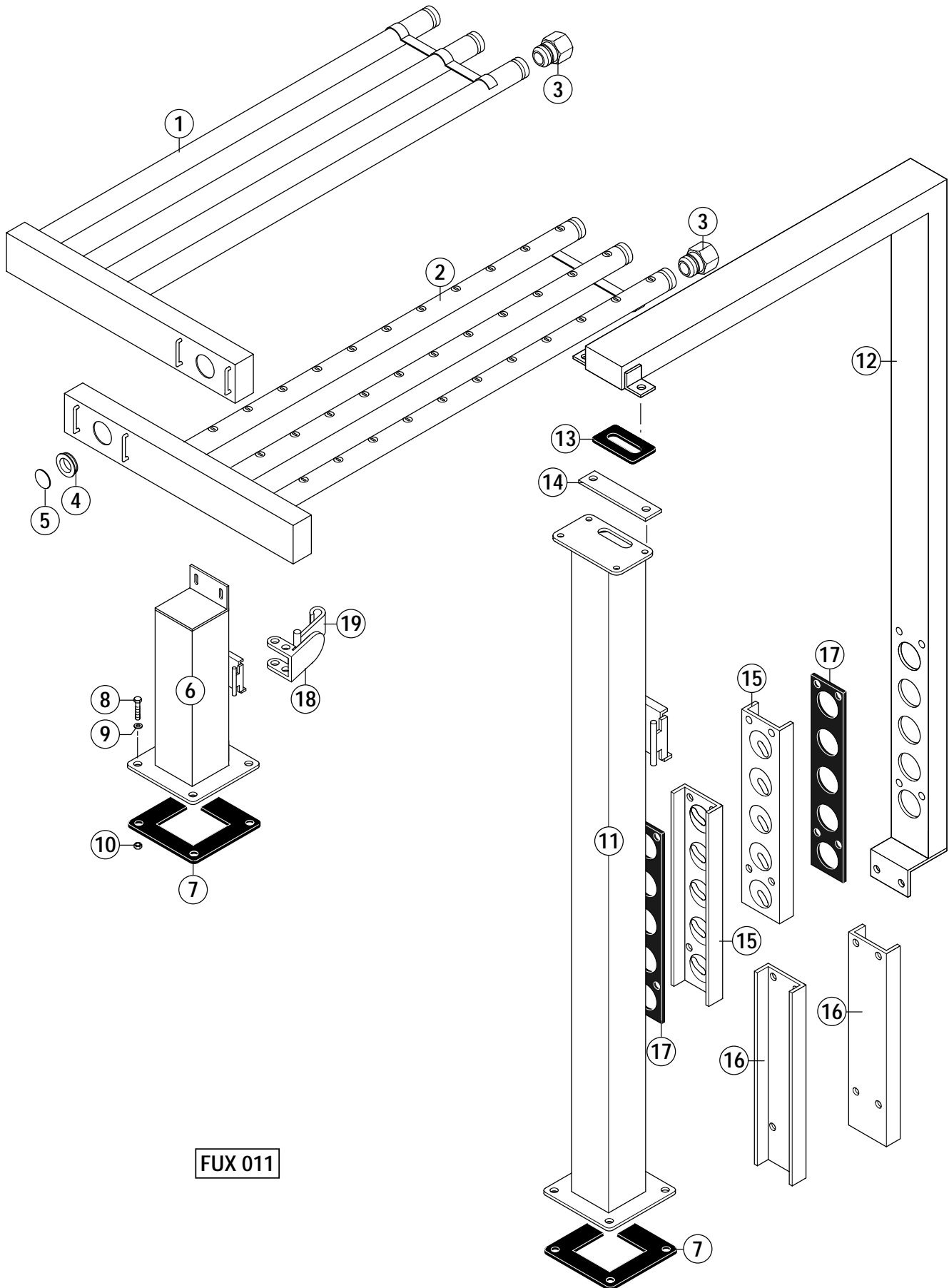



A conveyor width
largeur du convoyeur
Bandbreite
bandbreedte

B usable height
hauteur de passage
Durchlaufhöhe
doorvoerhoogte

C Entry length
Longueur d'entrée
Zulauflänge
Toevoerlengte

Pos.	L/R G/D	R/L D/G	Specifications / Spécifications / Angaben / Opgaven
1	375 228-4	380 144-4	A = 612 mm
	375 228-2	380 144-2	A = 965 mm
2	375 228-3	380 144-3	A = 612 mm
	375 228-1	380 144-1	A = 965 mm
3	106 769	=	
4	229 568	=	
5	67 500-81	=	
6	300 131-3	300 131-4	
7	296 709	=	
8	602 572	=	
9	602 307	=	
10	602 491	=	
11	300 129-7	300 129-8	B = 440 mm
	300 129-5	300 129-6	B = 683 mm
12	375 226-6	=	A = 612 mm / B = 440 mm
	375 226-7	=	A = 612 mm / B = 683 mm
	375 226-8	=	A = 965 mm / B = 440 mm
	375 226-3	=	A = 965 mm / B = 683 mm
13	230 219	=	
14	229 526	=	
15	230 235-1	=	
16	698 076-5	=	
17	230 231	=	
18	229 182	=	
19	229 112	=	

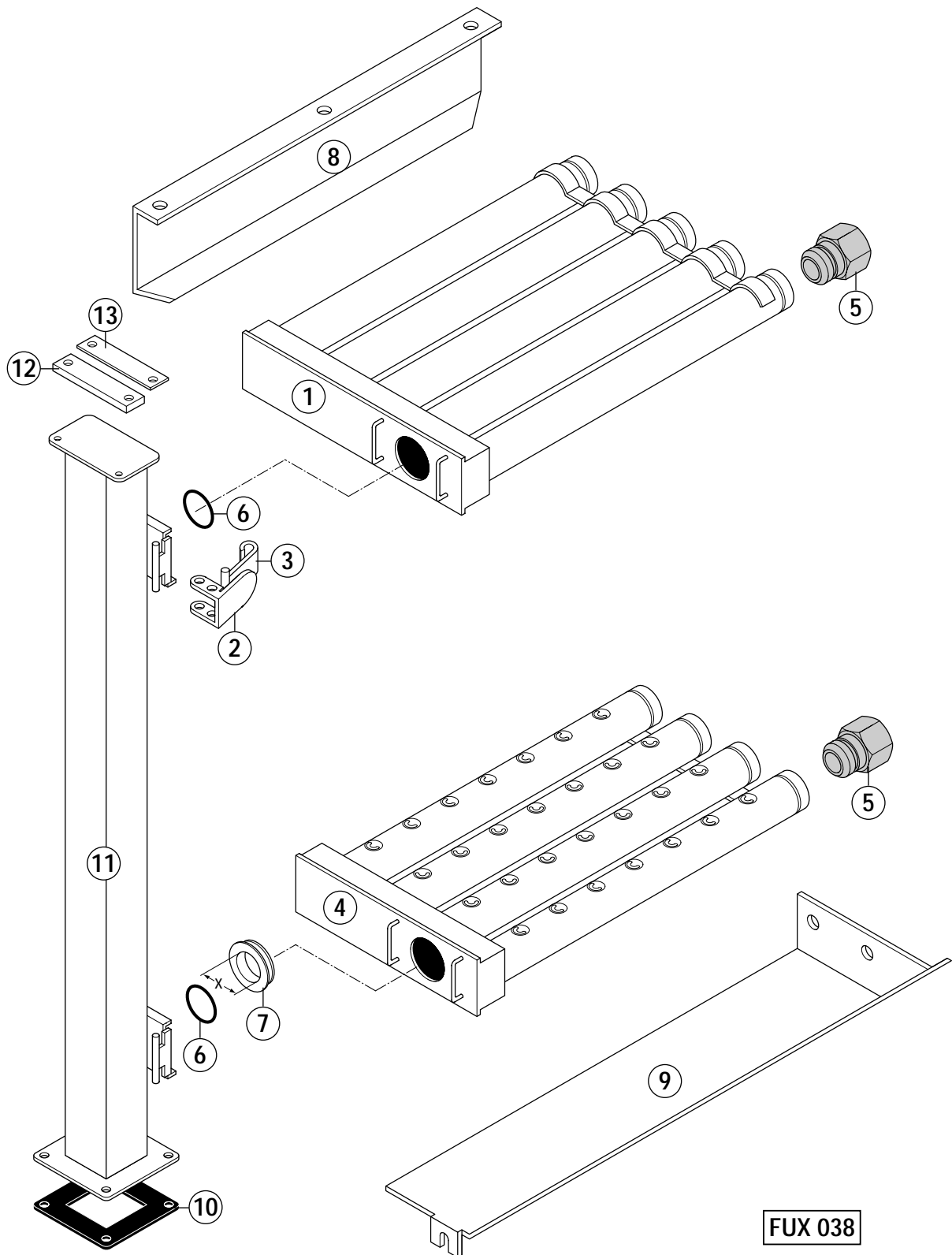



A conveyor width
 largeur du convoyeur
 Bandbreite
 bandbreedte

B usable height
 hauteur de passage
 Durchlaufhöhe
 doorvoerhoogte

C Entry length
 Longueur d'entrée
 Zulauflänge
 Toevoerlengte

Pos.	L/R G/D	R/L D/G	Specifications / Spécifications / Angaben / Opgaven
1	229 630-1	229 631-1	A = 612 mm
	229 976	229 972	A = 965 mm
2	229 182	=	
3	229 112	=	
4	229 057	=	A = 612 mm
	229 962	=	A = 965 mm
5	106 769	=	
6	67 500-81	=	
7	229 568-1	=	X = Ø 31 mm
	229 568-3	=	X = Ø 28 mm
	229 568-2	=	X = Ø 23 mm
	229 568-4	=	X = Ø 18 mm
8	229 524	=	A = 612 mm
	230 302	=	A = 965 mm
9	229 347	=	A = 612 mm
	230 305	=	A = 965 mm
10	296 709	=	
11	229 113-1	=	B = 440 mm
	229 113-2	=	B = 683 mm
12	229 526	=	
13	300 493	=	

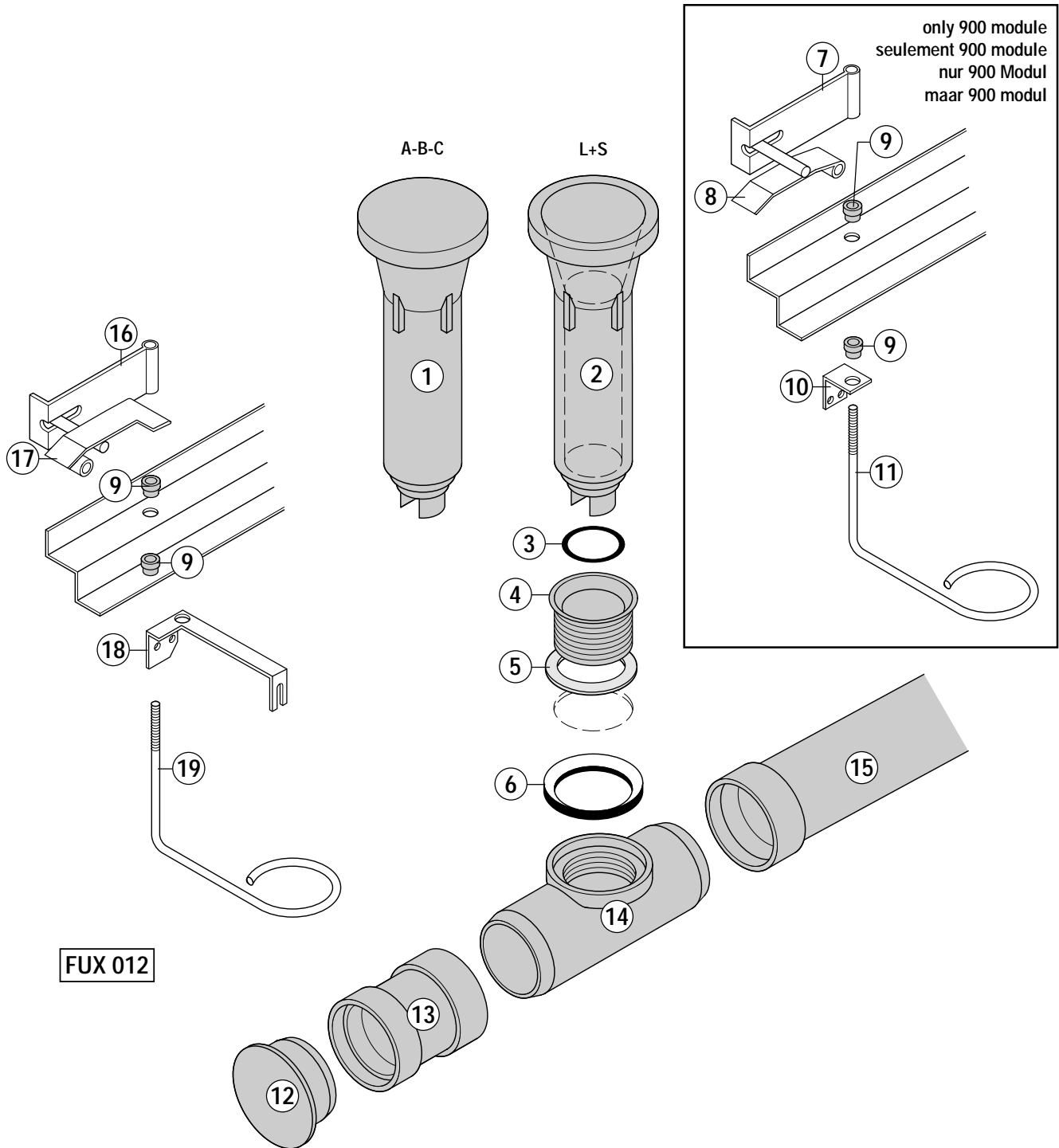



A conveyor width
largeur du convoyeur
Bandbreite
bandbreedte

B usable height
hauteur de passage
Durchlaufhöhe
doorvoerhoogte

C Entry length
Longueur d'entrée
Zulauflänge
Toevoerlengte

Pos.	L/R G/D	R/L D/G	Specifications / Spécifications / Angaben / Opgaven
1	229 427-1	=	
2	230 346-2 	=	
3	67 500-15	=	
4	226 558-1	=	see wiring diagramme / voir schéma de câblage / siehe Schaltplan / zie elektrisch schema
5	172 986-15	=	
6	226 556	=	
7	229 394	=	
8	230 039	=	
9	229 566	=	
10	229 153	=	
11	229 155	=	
12	229 681-1	=	
13	229 680-1	=	
14	229 491	=	
15	600 573	=	
16	375 213	=	
17	375 215-1	=	
18	375 211	=	
19	375 210-1	=	

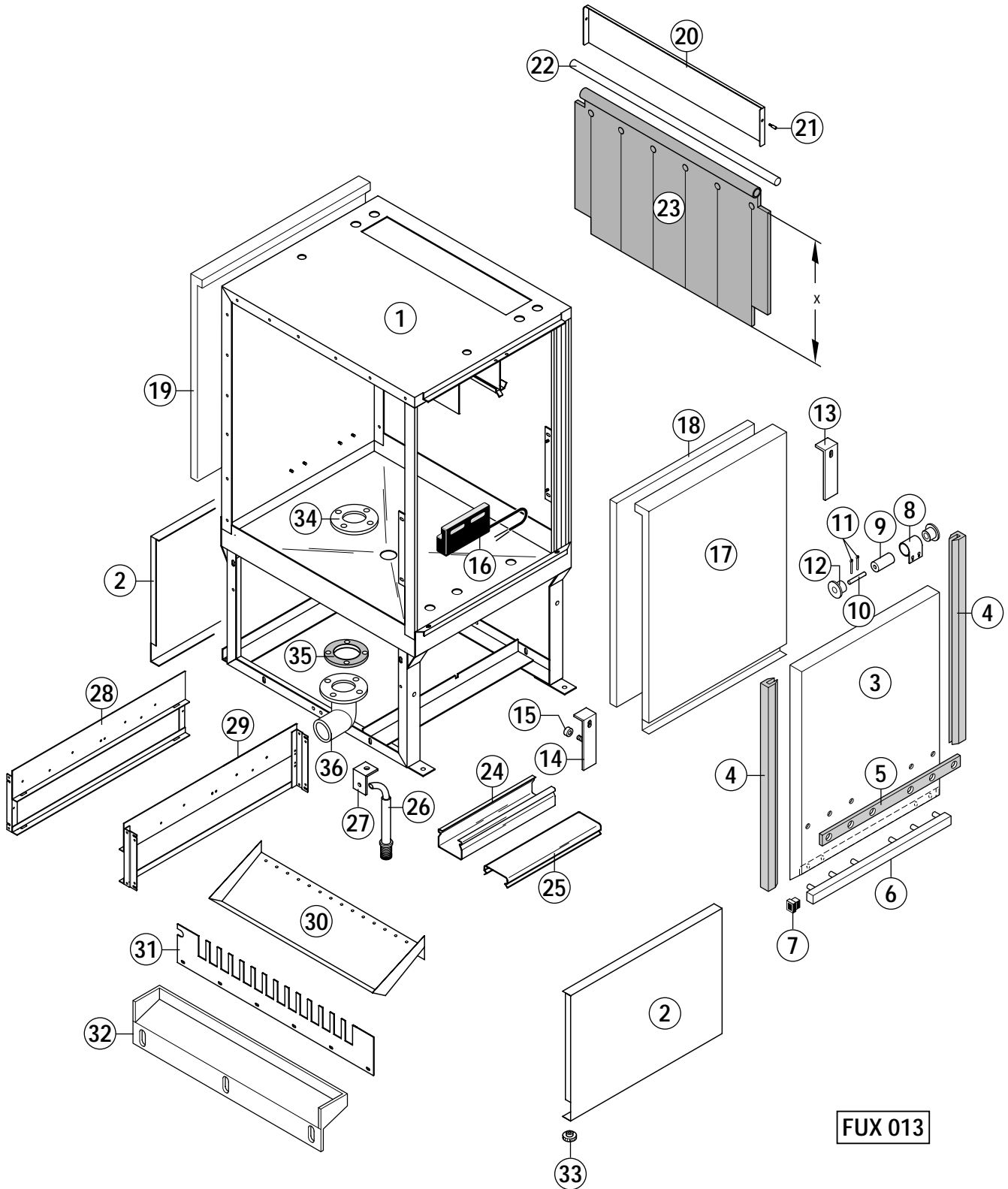

Pos.	L/R G/D	R/L D/G	Specifications / Spécifications / Angaben / Opgaven
1	379 556-5	379 557-5	A = 612 mm / B = 440 mm (with door / avec porte / mit Tür / met deur)
	379 556-3	379 557-3	A = 612 mm / B = 683 mm (with door / avec porte / mit Tür / met deur)
	379 556-6	379 557-6	A = 965 mm / B = 440 mm (with door / avec porte / mit Tür / met deur)
	379 556-4	379 557-4	A = 965 mm / B = 683 mm (with door / avec porte / mit Tür / met deur)
	698 612-1	=	A = 612 mm / B = 440 mm (without door / sans porte / ohne Tür / zonder deur)
	229 786	=	A = 612 mm / B = 683 mm (without door / sans porte / ohne Tür / zonder deur)
	230 380	=	A = 965 mm / B = 440 mm (without door / sans porte / ohne Tür / zonder deur)
	230 534	=	A = 965 mm / B = 683 mm (without door / sans porte / ohne Tür / zonder deur)
2	229 204-2	=	
3	229 790	=	B = 440 mm
	230 645	=	B = 683 mm
4	302 207-4	=	B = 440 mm
	302 207-6	=	B = 683 mm
5	229 805	=	
6	220 806	=	
7	229 532	=	
8	230 072	=	B = 440 mm without insulation / sans isolement / ohne Isolierung / zonder isolatie
	230 514	=	B = 683 mm without insulation / sans isolement / ohne Isolierung / zonder isolatie
	229 277	=	B = 440 mm with insulation / avec isolement / mit Isolierung / met isolatie
	229 473	=	B = 683 mm with insulation / avec isolement / mit Isolierung / met isolatie
9	173 481	=	
10	602 846	=	
11	602 886	=	
12	784 934-1	=	
13	303 517	=	
14	303 516	=	
15	166 964	=	
16	229 517-2	=	see wiring diagramme / voir schéma de câblage / siehe Schaltplan / zie elektrisch schema
17	374 712-6	=	B = 440 mm
	374 712-7	=	B = 683 mm
18	229 790	=	B = 440 mm
	230 645	=	B = 683 mm
19	230 510	=	B = 440 mm
	229 903	=	B = 683 mm
20	229 696	=	A = 612 mm
	230 420	=	A = 965 mm
21	603 548	=	
22	379 566-1	=	A = 612 mm (with door / avec porte / mit Tür / met deur)
	229 214	=	A = 612 mm (without door / sans porte / ohne Tür / zonder deur)
	229 924-1	=	A = 965 mm
23	379 565-1	=	A = 612 mm / B = 440 mm (x = 400 mm)
	379 565-2	=	A = 612 mm / B = 440 mm (x = 210 mm)
	229 436-3	=	A = 612 mm / B = 683 mm (x = 643 mm)
	229 436-1	=	A = 612 mm / B = 683 mm (x = 400 mm)
	229 436-4	=	A = 965 mm / B = 440 mm (x = 400 mm)
	229 436-5	=	A = 965 mm / B = 440 mm (x = 210 mm)
	229 436-6	=	A = 965 mm / B = 683 mm (x = 643 mm)
	229 436-4	=	A = 965 mm / B = 683 mm (x = 400 mm)
24	229 553-4	=	



A conveyor width
largeur du convoyeur
Bandbreite
bandbreedte

B usable height
hauteur de passage
Durchlaufhöhe
doorvoerhoogte

C Entry length
Longueur d'entrée
Zulauflänge
Toevoerlengte

Pos.	L/R G/D	R/L D/G	Specifications / Spécifications / Angaben / Opgaven
25	229 561-7	=	
26	693 299	=	
27	229 731	=	
28	229 215-2	=	
29	229 216-2	=	
30	885 133-1	=	A = 612 mm
	230 379	=	A = 965 mm
31	300 559	=	A = 612 mm
	375 644	=	A = 965 mm
32	698 079-1	=	A = 612 mm
	698 079-2	=	A = 965 mm
33	229 525	=	
34	732 998-2	=	
35	733 032-1	=	
36	732 996-2	=	

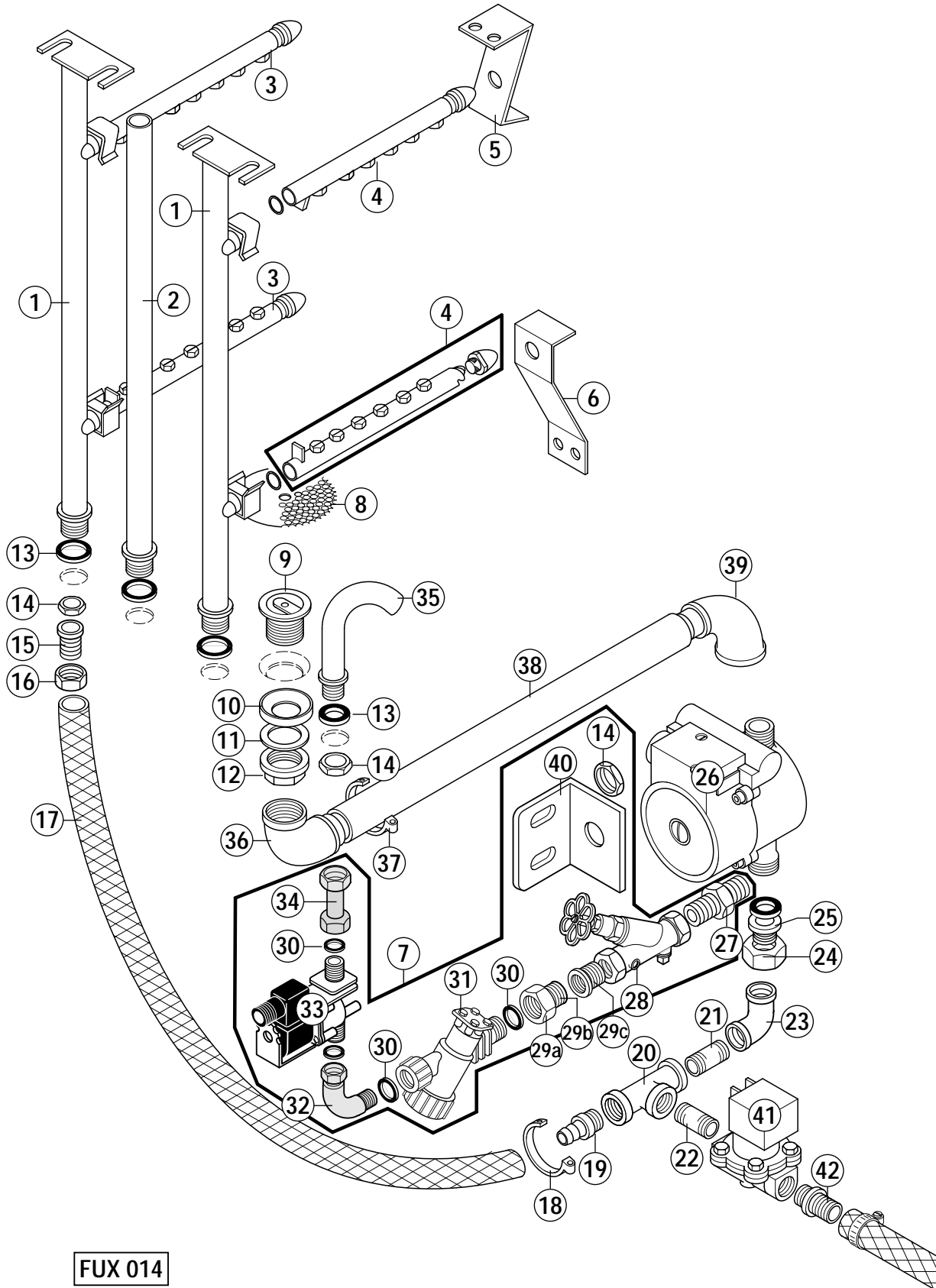

FUX 014

Pos.	L/R G/D	R/L D/G	Specifications / Spécifications / Angaben / Opgaven
1	229 320-1	229 320-2	B = 440 mm (without door / sans porte / ohne Tür / maar deuren)
	229 883-1	229 883	B = 683 mm (without door / sans porte / ohne Tür / maar deuren)
	374 729-2	374 729-1	B = 440 mm (with door / avec porte / mit Tür / met deuren)
	374 729-16	374 729-17	B = 683 mm (with door / avec porte / mit Tür / met deuren)
2	229 476	=	B = 440 mm (without door / sans porte / ohne Tür / maar deuren)
	229 793	=	B = 683 mm (without door / sans porte / ohne Tür / maar deuren)
	374 731-1	=	B = 440 mm (with door / avec porte / mit Tür / met deuren)
	374 731-4	=	B = 683 mm (with door / avec porte / mit Tür / met deuren)
3	229 511-2	=	A = 612 mm
	303 450-2	=	A = 965 mm
4	229 511-2	=	A = 612 mm
	303 450-1	=	A = 965 mm
5	229 328	=	
6	229 329	=	
7	887 819-1	=	
8	230 932	=	
9	229 444	=	
10	226 556	=	
11	228 694-3	=	
12	226 557	=	
13	172 986-3	=	
14	172 739-2	=	
15	602 402	=	
16	600 805	=	
17	226 994-9	=	
18	166 513-3	=	
19	229 702-1	=	
20	603 165	=	
21	603 715	=	
22	602 938	=	
23	602 770	=	
24	602 410	=	
25	600 409	=	
26	229 060-10	=	see wiring diagramme / voir schéma de câblage / siehe Schaltplan / zie elektrisch schema
27	227 931	=	
28	774 844-1	=	
29a	602 407	=	
29b	602 402	=	
29c	603 073	=	
30	168 611-9	=	
31	774 810-1	=	
32	884 029-3	=	
33	734 242-3	=	
34	884 029-1	=	
35	693 299-1	=	
36	229 874	=	
37	166 513-3	=	
38	229 873-1	=	
39	603 152	=	
40	887 819-1	=	



A conveyor width
largeur du convoyeur
Bandbreite
bandbreedte

B usable height
hauteur de passage
Durchlaufhöhe
doorvoerhoogte

C Entry length
Longueur d'entrée
Zulauflänge
Toevoerlengte

Pos.	L/R G/D	R/L D/G	Specifications / Spécifications / Angaben / Opgaven
41	229 677-1	=	see wiring diagramme / voir schéma de câblage / siehe Schaltplan / zie elektrisch schema
42	229 683-1	=	

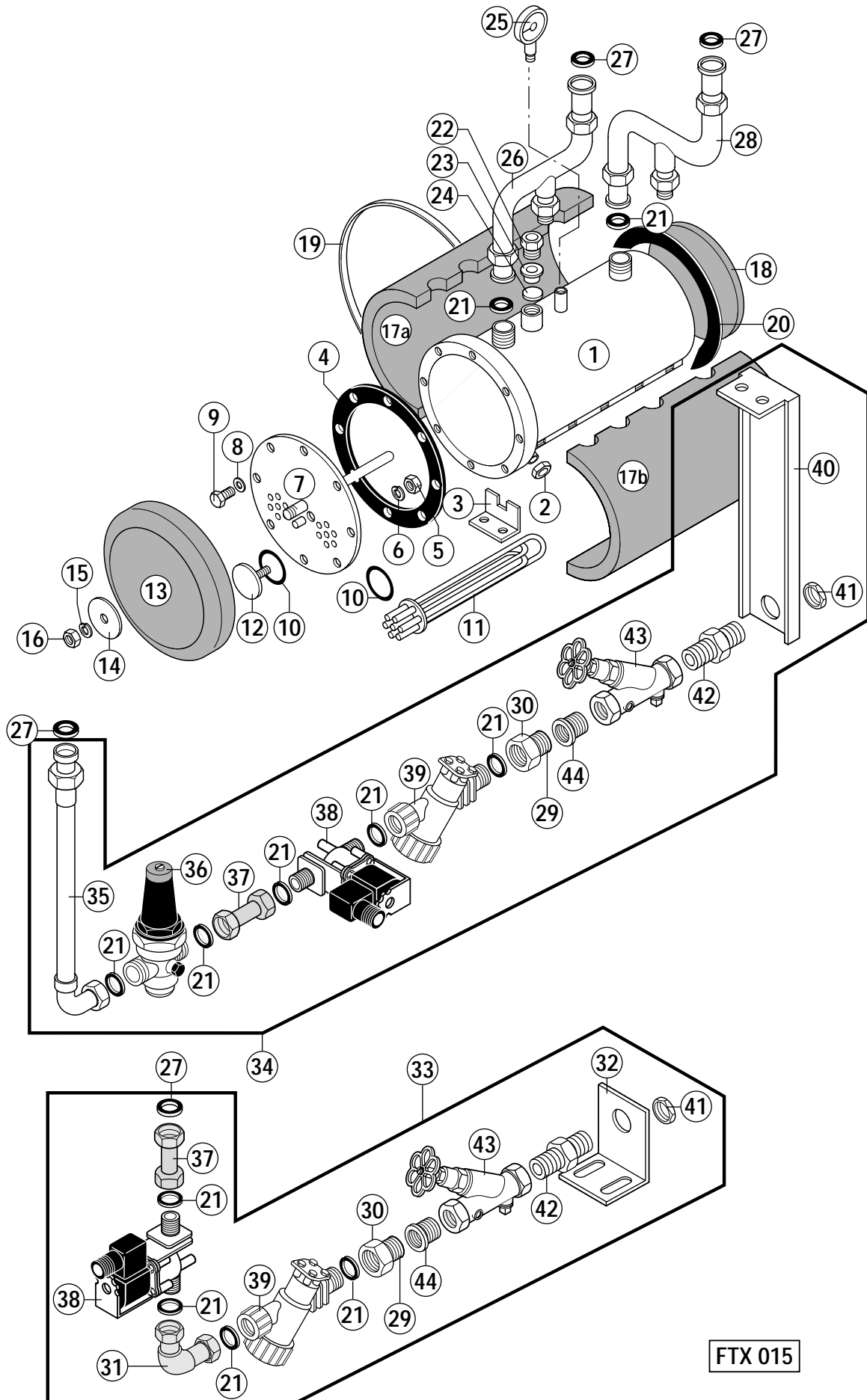

FTX 015

Pos.	L/R G/D	R/L D/G	Specifications / Spécifications / Angaben / Opgaven
1	300 686	=	785 mm (long version / version long / lange Version / lange versie)
	230 869	=	592 mm (short version / version bref / kurze Version / korte versie)
2	602 794	=	
3	229 249	=	
4	230 994	=	
5	602 493	=	M 10
6	602 295	=	B 10
7	300 692-1	=	18 kW
	300 692-2	=	27 kW
	300 692-3	=	36 kW
8	602 288	=	A 10
9	603 116	=	M 10 x 30
10	67 500-118	=	
11	229 148-1	=	220 V see wiring diagramme / voir schéma de câblage / siehe Schaltplan / zie elektrisch schema
	229 148-2	=	240 V see wiring diagramme / voir schéma de câblage / siehe Schaltplan / zie elektrisch schema
	229 148-5	=	254 V see wiring diagramme / voir schéma de câblage / siehe Schaltplan / zie elektrisch schema
12	229 585	=	
13	229 491	=	
14	228 694-4	=	
15	602 307	=	B 6
16	602 502	=	M 6
17a	229 579	=	(long version / version long / lange Version / lange versie)
	231 578	=	(short version / version bref / kurze Version / korte versie)
17b	229 579	=	(long version / version long / lange Version / lange versie)
	231 577	=	(short version / version bref / kurze Version / korte versie)
18	229 493	=	
19	169 139-3	=	
20	229 489	=	
21	168 611-9	=	
22	230 036	=	UK only / nur UK / seulement UK / maar UK
23	230 035	=	UK only / nur UK / seulement UK / maar UK
24	137 146	=	UK only / nur UK / seulement UK / maar UK
25	229 583-1	=	
26	300 705	=	
27	168 611-9	=	
28	300 707	=	
29	602 402	=	G 3/4
30	602 407	=	G 3/4
31	884 029-3	=	
32	887 833-1	=	
33	887 819-1	=	
34	887 820-1	=	
35	896 166-1	=	
36	229 110-2	=	
37	884 029-1	=	
38	734 242-3	=	see wiring diagramme / voir schéma de câblage / siehe Schaltplan / zie elektrisch schema
39	774 810-1	=	
40	887 826-1	=	
41	172 739-2	=	

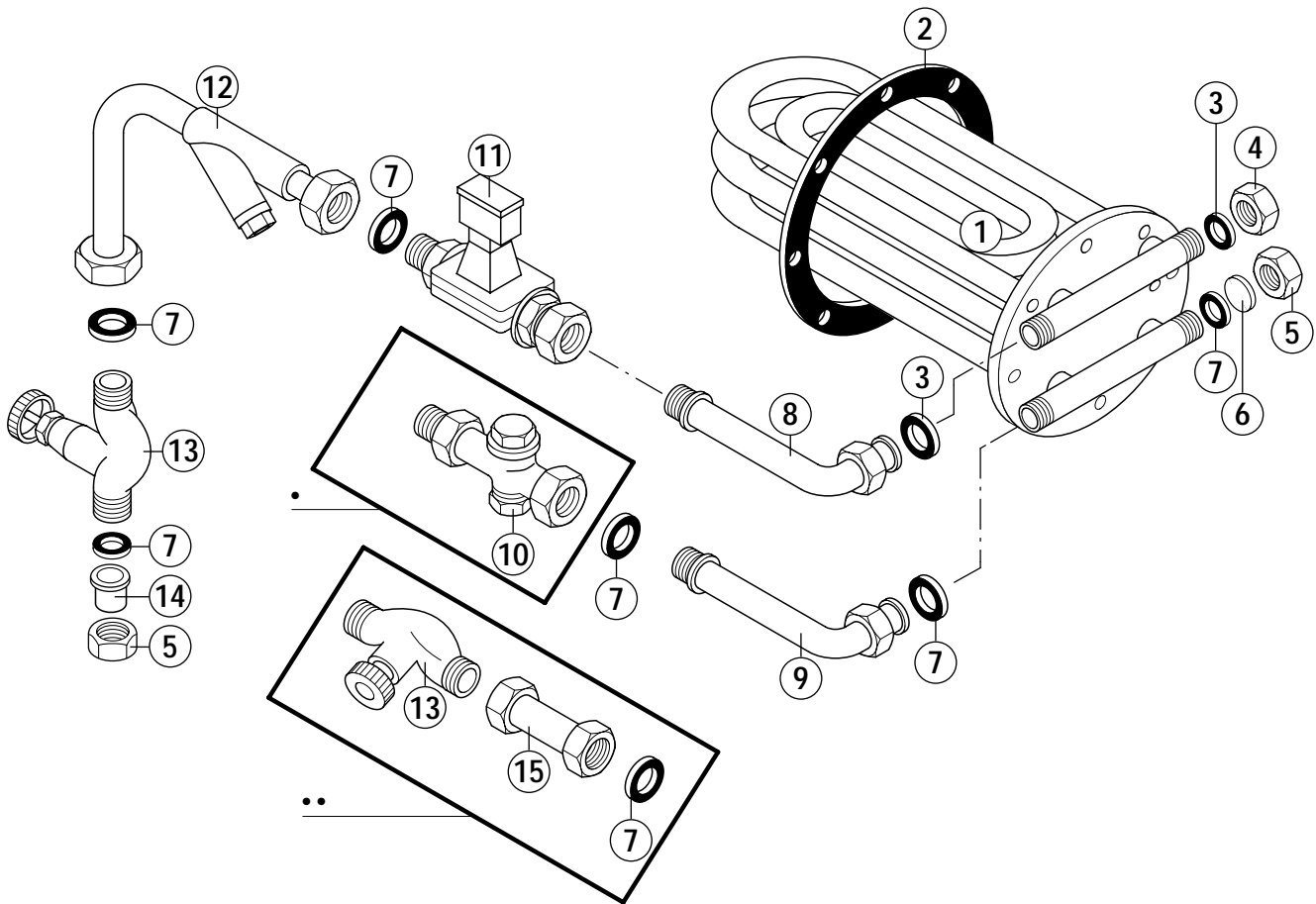

FUX 016

- steam
vapeur
Dampf
stoom
- hot water
eau chaude
Heißwasser
heet water



A conveyor width
 largeur du convoyeur
 Bandbreite
 bandbreedte

B usable height
 hauteur de passage
 Durchlaufhöhe
 doorvoerhoogte

C Entry length
 Longueur d'entrée
 Zulauflänge
 Toevoerlengte

Pos.	L/R G/D	R/L D/G	Specifications / Spécifications / Angaben / Opgaven
1	300 696	=	A = 965 mm
	300 696	=	A = 965 / 612 mm (without door / sans porte / ohne Tür / zonder deuren)
	230 980	=	A = 965 / 612 mm (with door / avec porte / mit Tür / met deuren)
2	230 994	=	
3	302 574-4	=	
4	300 556	=	
5	168 610-1	=	
6	694 443	=	
7	302 574-1	=	
8	229 725	=	
9	229 726	=	
10	168 704	=	0,1 - 3,5 bar
	302 507	=	3,5 - 21 bar
11	869 493-1	=	see wiring diagramme / voir schéma de câblage / siehe Schaltplan / zie elektrisch schema
12	229 664	=	
13	165 828-2	=	
14	168 608-3	=	
15	229 665	=	

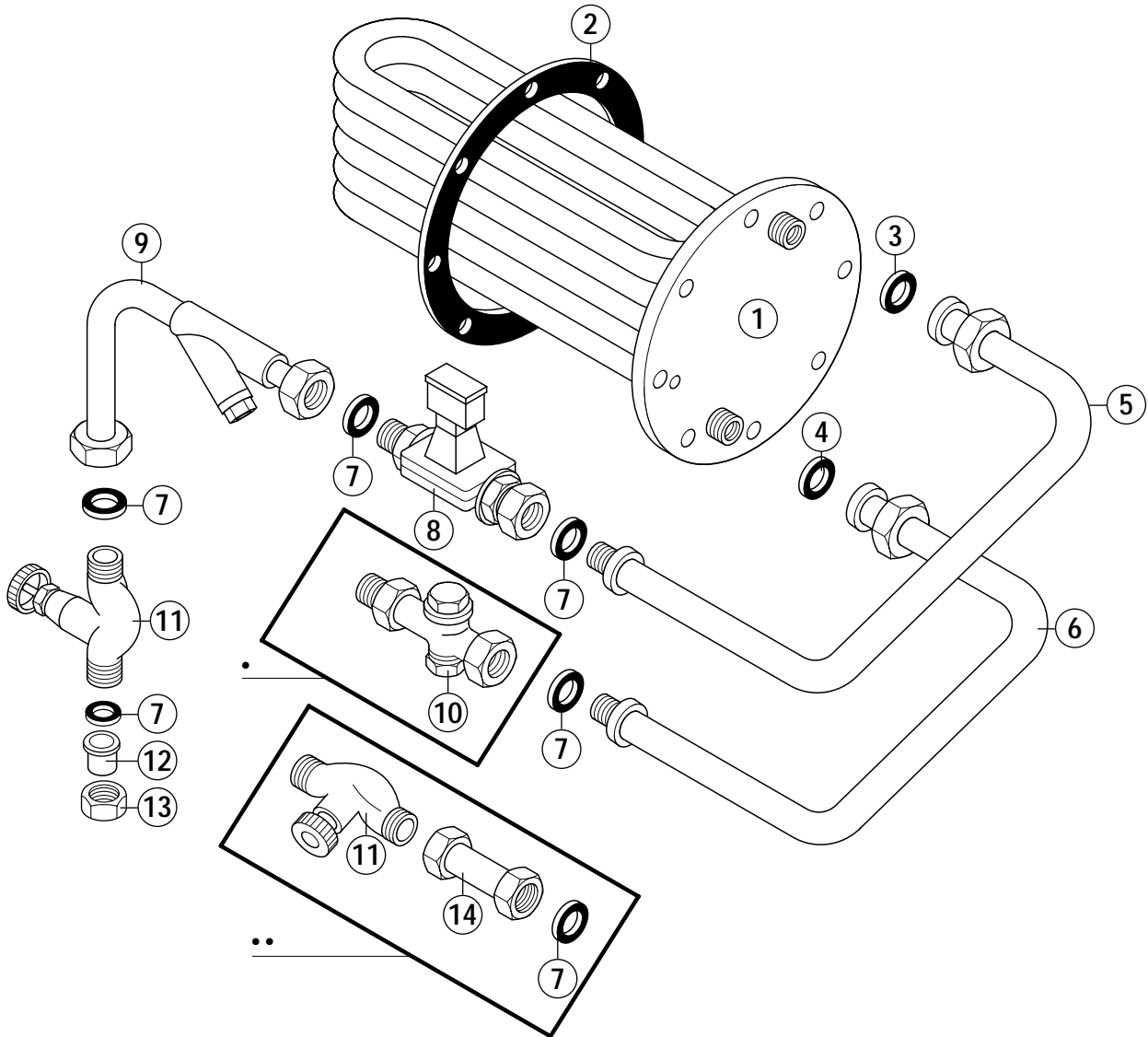

FUX 017

- steam
vapeur
Dampf
stoom
- hot water
eau chaude
Heißwasser
heet water



A conveyor width
largeur du convoyeur
Bandbreite
bandbreedte

B usable height
hauteur de passage
Durchlaufhöhe
doorvoerhoogte

C Entry length
Longueur d'entrée
Zulauflänge
Toevoerlengte

Pos.	L/R G/D	R/L D/G	Specifications / Spécifications / Angaben / Opgaven
1	300 834	=	A = 965 mm
	300 834	=	A = 965 / 612 mm (without door / sans porte / ohne Tür / zonder deuren)
	230 979	=	A = 965 / 612 mm (with door / avec porte / mit Tür / met deuren)
2	230 994	=	
3	168 611-15	=	
4	300 084-6	=	
5	229 713-2	=	
6	229 713-1	=	
7	300 084-6	=	
8	869 493-1	=	see wiring diagramme / voir schéma de câblage / siehe Schaltplan / zie elektrisch schema
9	229 664	=	
10	168 704	=	0,1 - 3,5 bar
	302 507	=	3,5 - 21 bar
11	165 828-2	=	
12	168 608-3	=	
13	168 610-1	=	
14	229 665	=	

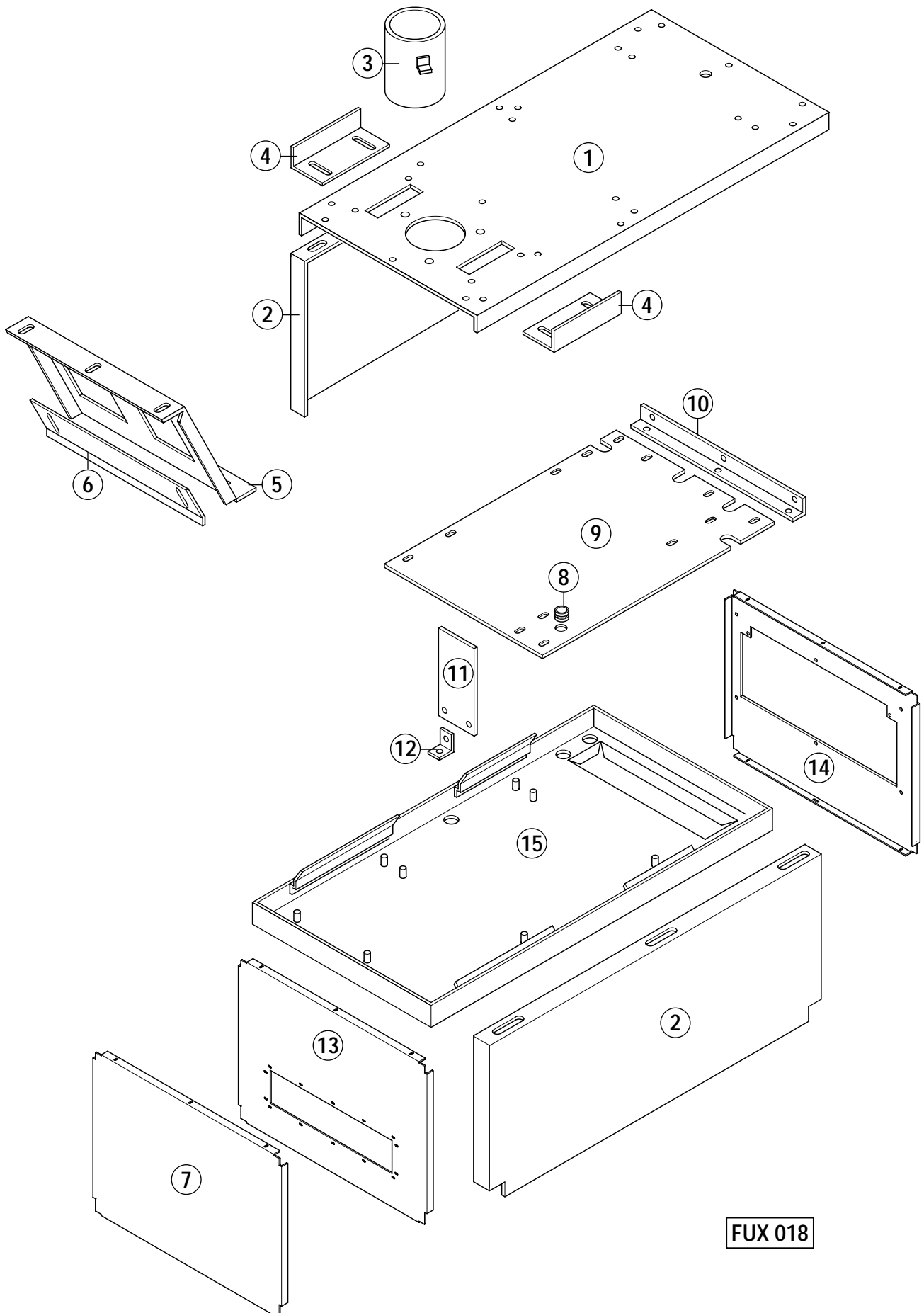
**FUX 018**



A conveyor width
largeur du convoyeur
Bandbreite
bandbreedte

B usable height
hauteur de passage
Durchlaufhöhe
doorvoerhoogte

C Entry length
Longueur d'entrée
Zulauflänge
Toevoerlengte

Pos.	L/R G/D	R/L D/G	Specifications / Spécifications / Angaben / Opgaven
1	303 478	=	A = 612 mm
	230 419	=	A = 965 mm
2	229 440-1	=	
3	229 438	=	
4	228 336	=	
5	229 420	=	A = 612 mm
	230 437	=	A = 965 mm
6	231 662	=	A = 612 mm
	300 631	=	A = 965 mm
7	225 287-1	=	A = 612 mm
	230 401-1	=	A = 965 mm
8	227 748-1	=	
9	229 429	=	A = 612 mm
	230 406	=	A = 965 mm
10	230 355	=	A = 612 mm
	230 412	=	A = 965 mm
11	229 430	=	
12	229 432	=	
13	300 867-1	=	A = 612 mm
	300 867-2	=	A = 965 mm
14	229 287-2	=	A = 612 mm
	230 401-2	=	A = 965 mm
15	229 390	=	A = 612 mm
	230 400	=	A = 965 mm

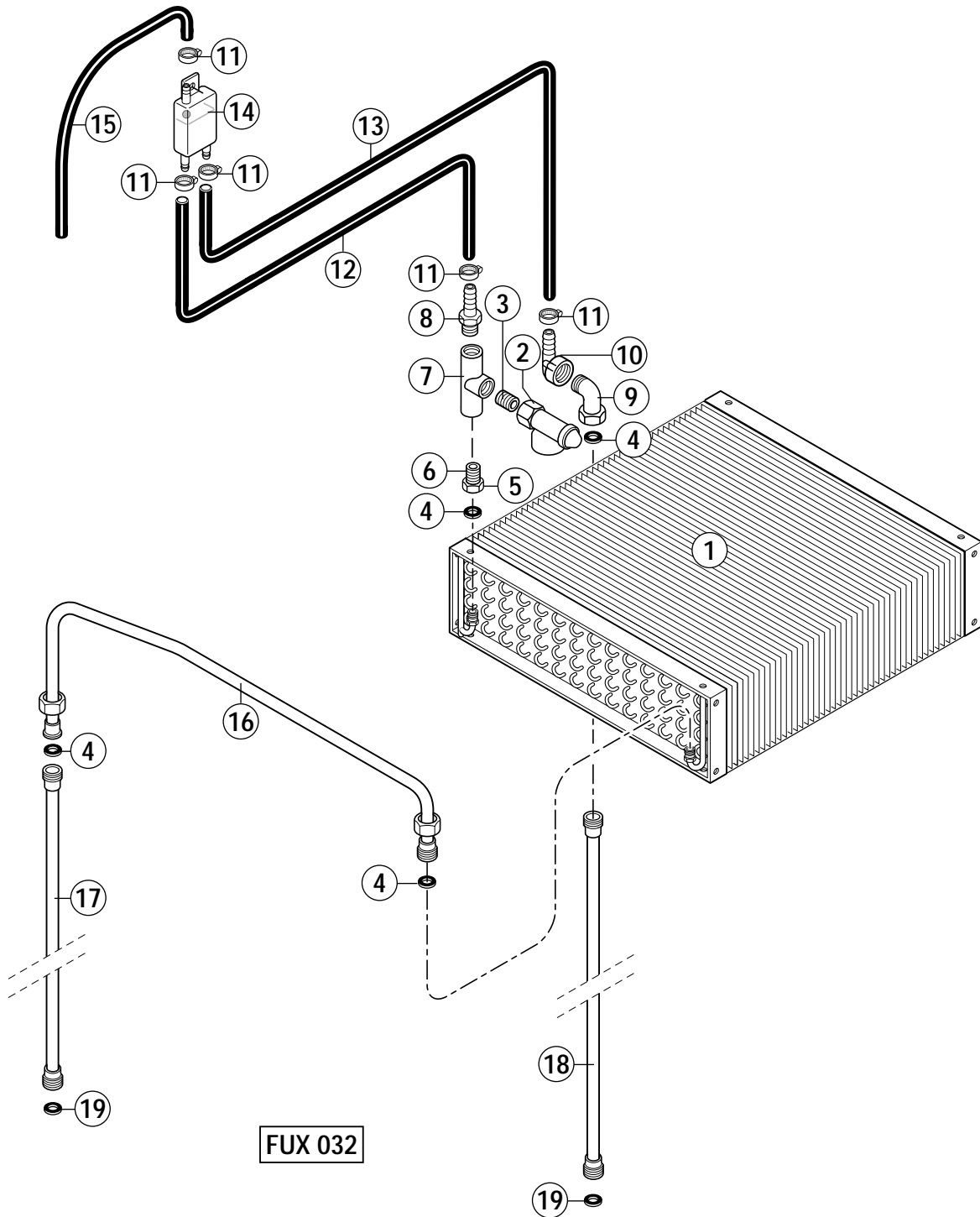



A conveyor width
largeur du convoyeur
Bandbreite
bandbreedte

B usable height
hauteur de passage
Durchlaufhöhe
doorvoerhoogte

C Entry length
Longueur d'entrée
Zulauflänge
Toevoerlengte

Pos.	L/R G/D	R/L D/G	Specifications / Spécifications / Angaben / Opgaven
1	229 380-1	=	A = 612 mm
	229 380-4	=	A = 965 mm
2	229 621-1	=	
3	602 938	=	
4	168 611-9	=	
5	600 805	=	
6	602 402	=	
7	603 162	=	
8	299 290-1	=	
9	379 564	=	
10	229 240-1	=	
11	166 513-4	=	
12	324 073-6	=	
13	324 077-20	=	
14	324 091	=	
15	324 077-10	=	
16	229 406	=	
17	693 296-1	=	B = 440 mm (without door / sans porte / ohne Tür / zonder deuren)
	693 296-3	=	B = 683 mm (without door / sans porte / ohne Tür / zonder deuren)
	693 296-2	=	B = 440 mm (with door / avec porte / mit Tür / met deuren)
	693 296-4	=	B = 683 mm (with door / avec porte / mit Tür / met deuren)
18	229 466	=	B = 440 mm (without door / sans porte / ohne Tür / zonder deuren)
	229 791	=	B = 683 mm (without door / sans porte / ohne Tür / zonder deuren)
	374 733-1	=	B = 440 mm (with door / avec porte / mit Tür / met deuren)
	374 731-4	=	B = 683 mm (with door / avec porte / mit Tür / met deuren)
19	172 986-11	=	

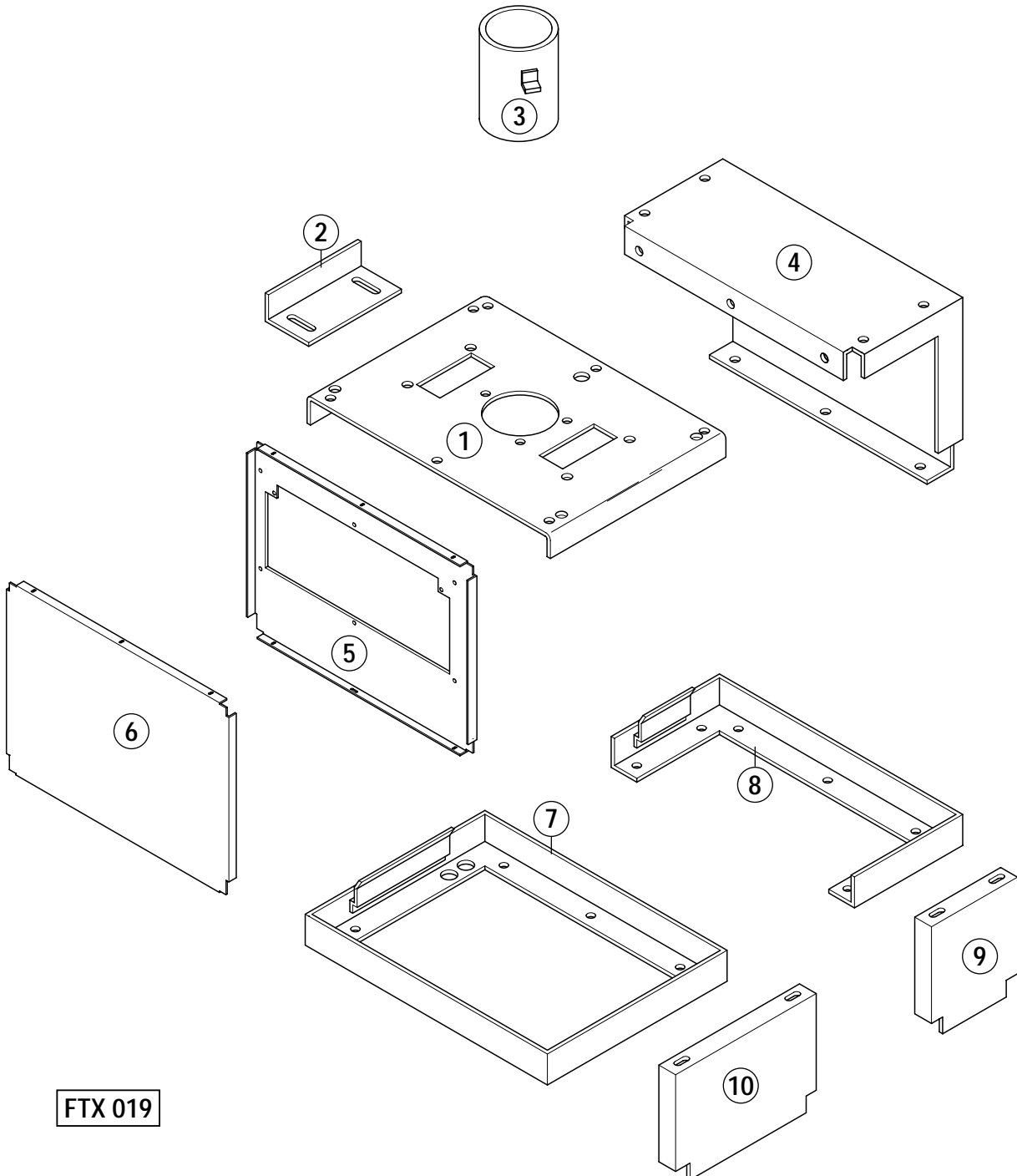
**FTX 019**



A conveyor width
largeur du convoyeur
Bandbreite
bandbreedte

B usable height
hauteur de passage
Durchlaufhöhe
doorvoerhoogte

C Entry length
Longueur d'entrée
Zulauflänge
Toevoerlengte

Pos.	L/R G/D	R/L D/G	Specifications / Spécifications / Angaben / Opgaven
1	229 943	=	A = 612 mm
	230 450	=	A = 965 mm
2	228 336	=	
3	229 438	=	
4	229 694	=	A = 612 mm
	230 443	=	A = 965 mm
5	229 287-2	=	A = 612 mm
	230 401-2	=	A = 965 mm
6	229 287-1	=	A = 612 mm
	230 401-1	=	A = 965 mm
7	229 951	=	A = 612 mm
	230 448	=	A = 965 mm
8	229 691	=	A = 612 mm
	230 441	=	A = 965 mm
9	229 440-3	=	
10	229 440-4	=	

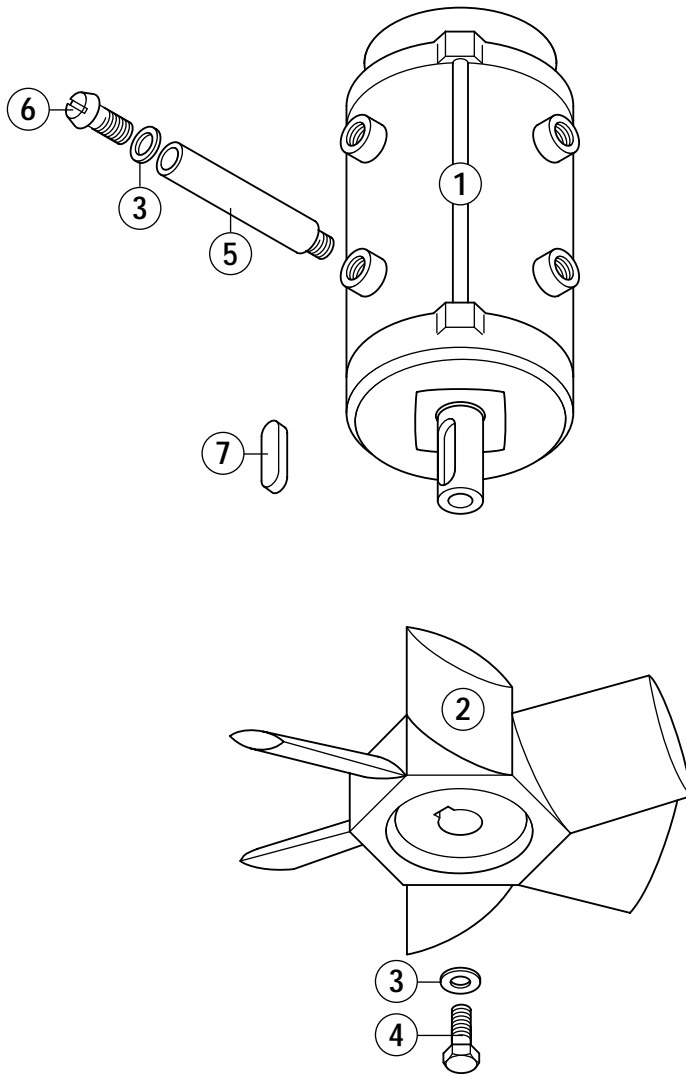
**FUX 020**



A conveyor width
largeur du convoyeur
Bandbreite
bandbreedte

B usable height
hauteur de passage
Durchlaufhöhe
doorvoerhoogte

C Entry length
Longueur d'entrée
Zulauflänge
Toevoerlengte

Pos.	L/R G/D	R/L D/G	Specifications / Spécifications / Angaben / Opgaven
1	145 075-1	=	C1 see wiring diagramme / voir schéma de câblage / siehe Schaltplan / zie elektrisch schema
	145 075-6	=	C2 see wiring diagramme / voir schéma de câblage / siehe Schaltplan / zie elektrisch schema
2	38 933-9	=	50 Hz / Ø 236 mm
	38 933-10	=	50 Hz / Ø 296 mm
3	602 286	=	A 6
4	602 570	=	M 6 x 16
5	781 587-1	=	0,18 kW
	693 877-2	=	0,37 kW
6	602 660	=	M 6 x 16
7	603 691	=	

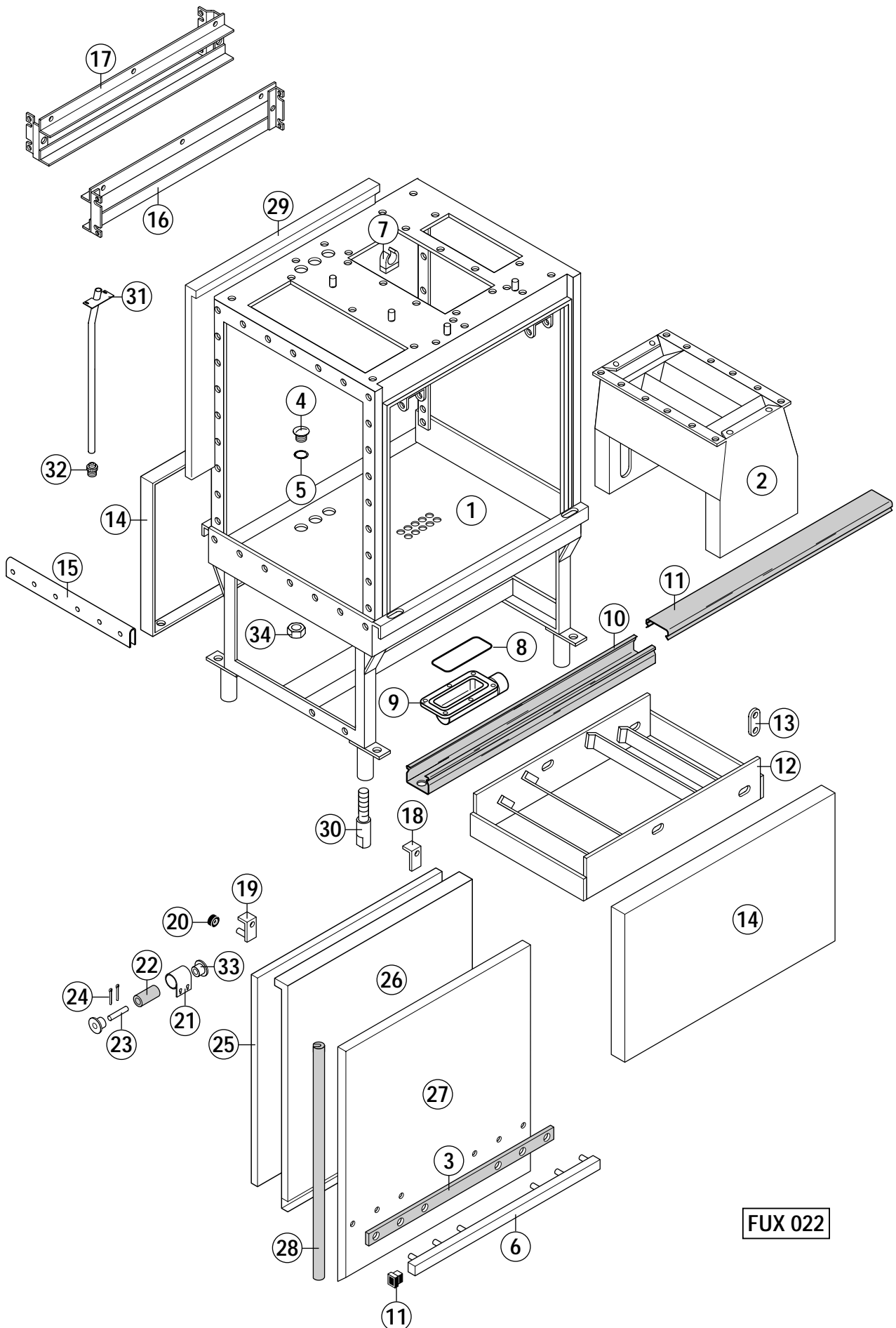

FUX 022

Pos.	L/R G/D	R/L D/G	Specifications / Spécifications / Angaben / Opgaven
1	229 250	229 678	A = 612 mm / B = 440 mm
	229 804	229 801	A = 612 mm / B = 683 mm
	230 433	230 476	A = 965 mm / B = 440 mm
	230 600	230 601	A = 965 mm / B = 683 mm
2	229 274	=	A = 612 mm / B = 440 mm
	229 825	=	A = 612 mm / B = 683 mm
	230 453	=	A = 965 mm / B = 440 mm
	230 608	=	A = 965 mm / B = 683 mm
3	229 531-1	=	
4	229 729-1	=	
5	276 903-9	=	
6	229 532	=	
7	379 213-1	=	
8	276 903-35	=	
9	325 529-1	=	
10	229 553-1	=	
11	229 532	=	
12	374 806-1	=	A = 612 mm
	374 806-2	=	A = 965 mm
13	229 325-1	=	
14	229 204-1	=	
15	229 401	=	A = 612 mm
	230 310	=	A = 965 mm
16	229 216-1	229 215-1	
17	229 215-1	229 216-1	
18	303 517	=	
19	303 516	=	
20	774 714-1	=	
21	229 277	=	
22	173 481	=	
23	602 839	=	
24	603 274	=	
25	229 132	=	B = 440 mm
	229 816	=	B = 683 mm
26	374 712-2	=	B = 440 mm
	374 712-3	=	B = 683 mm
27	229 132	=	B = 440 mm
	229 816	=	B = 683 mm
28	302 207-4	=	B = 440 mm
	302 207-6	=	B = 683 mm
29	230 508	=	B = 440 mm
	229 901	=	B = 683 mm
30	166 066-3	=	
31	229 289	=	B = 440 mm
	229 289-1	=	B = 683 mm
32	229 278	=	
33	784 934-1	=	
34	169 045-5	=	

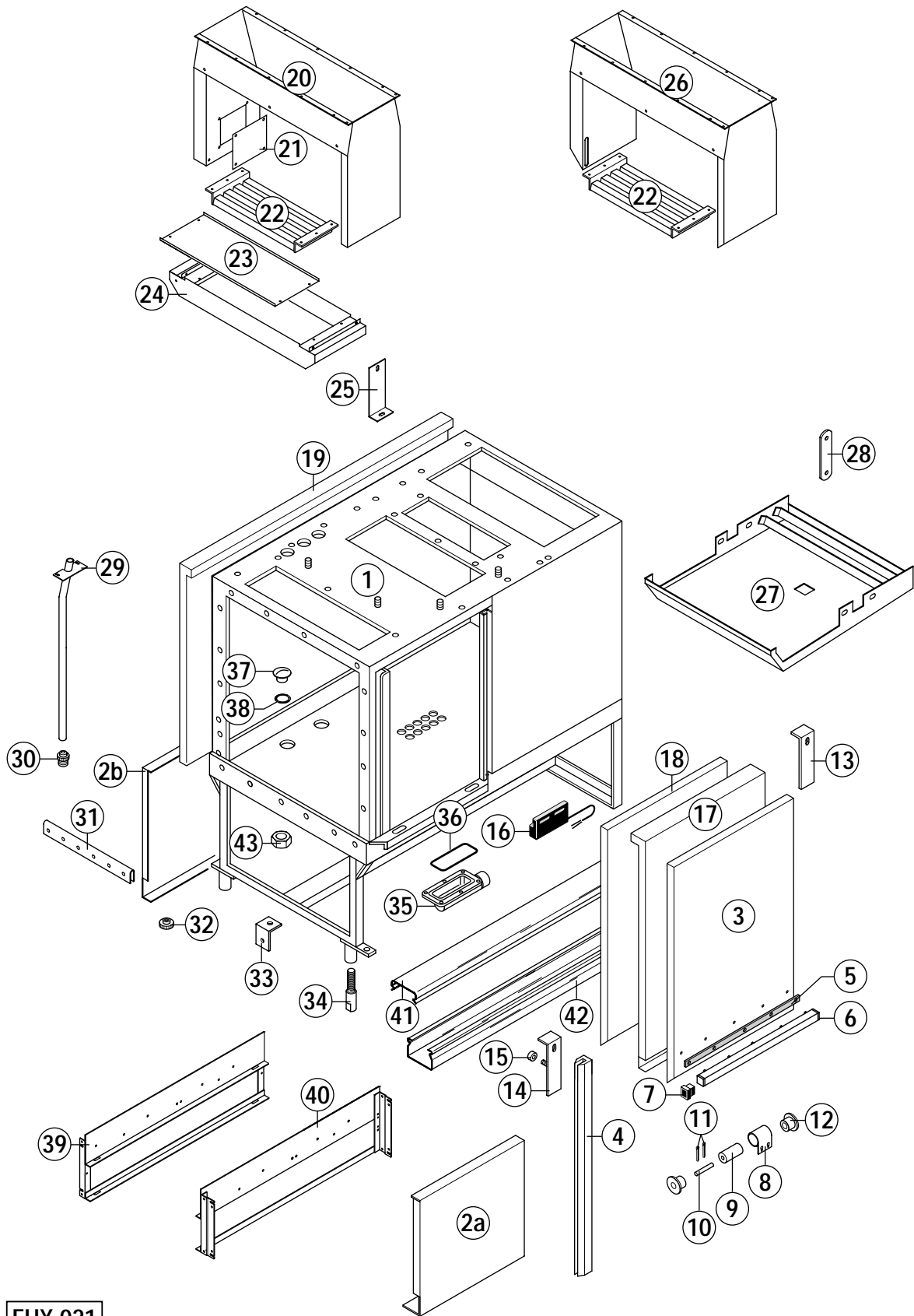

FUX 021

Pos.	L/R G/D	R/L D/G	Specifications / Spécifications / Angaben / Opgaven
1	379 558	379 522	A = 612 mm / B = 440 mm
	379 579	379 572	A = 612 mm / B = 683 mm
	379 618	379 631	A = 965 mm / B = 440 mm
	379 635	379 640	A = 965 mm / B = 683 mm
2a	229 204-2	=	
2b	229 204-3	=	
3	229 790	=	B = 440 mm
	230 645	=	B = 683 mm
4	302 207-4	=	B = 440 mm
	302 207-6	=	B = 683 mm
5	229 805	=	
6	220 806	=	
7	229 532	=	
8	230 072	=	B = 440 mm without insulation / sans isolement / ohne Isolierung / zonder isolatie
	230 514	=	B = 683 mm without insulation / sans isolement / ohne Isolierung / zonder isolatie
	229 277	=	B = 440 mm with insulation / avec isolement / mit Isolierung / met isolatie
	229 473	=	B = 683 mm with insulation / avec isolement / mit Isolierung / met isolatie
9	173 481	=	
10	602 846	=	
11	602 886	=	
12	784 934-1	=	
13	303 517	=	
14	303 516	=	
15	166 964	=	
16	229 517-2	=	see wiring diagramme / voir schéma de câblage / siehe Schaltplan / zie elektrisch schema
17	374 712-6	=	B = 440 mm
	374 712-7	=	B = 683 mm
18	229 790	=	B = 440 mm
	230 645	=	B = 683 mm
19	379 534	=	B = 440 mm
	379 577	=	B = 683 mm
20	731 508-1	=	A = 612 mm / B = 440 mm
	731 508-3	=	A = 612 mm / B = 683 mm
	731 508-2	=	A = 965 mm / B = 440 mm
	731 508-4	=	A = 965 mm / B = 683 mm
21	731 514-1	=	
22	731 511-1	=	A = 612 mm
	731 511-2	=	A = 965 mm
23	375 114-6	=	A = 612 mm
	375 114-7	=	A = 965 mm
24	375 113-6	=	A = 612 mm
	375 113-7	=	A = 965 mm
25	229 536	=	
26	731 522-1	=	A = 612 mm / B = 440 mm
	731 522-3	=	A = 612 mm / B = 683 mm
	731 522-2	=	A = 965 mm / B = 440 mm
	731 522-4	=	A = 965 mm / B = 683 mm
27	374 806-1	=	A = 612 mm
	374 806-2	=	A = 965 mm
28	229 325-1	=	

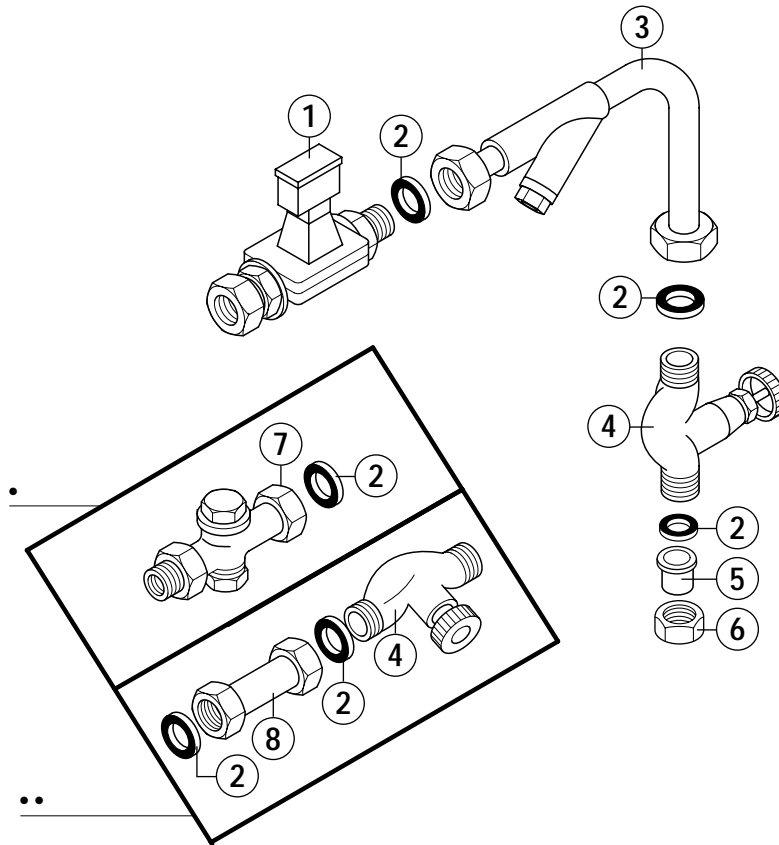

FUX 024

- steam
vapeur
Dampf
stoom
- hot water
eau chaude
Heißwasser
heet water



A conveyor width
largeur du convoyeur
Bandbreite
bandbreedte

B usable height
hauteur de passage
Durchlaufhöhe
doorvoerhoogte

C Entry length
Longueur d'entrée
Zulauflänge
Toevoerlengte

Pos.	L/R G/D	R/L D/G	Specifications / Spécifications / Angaben / Opgaven
1	869 493-1	=	see wiring diagramme / voir schéma de câblage / siehe Schaltplan / zie elektrisch schema
2	302 574-1	=	
3	229 664	=	
4	165 828-2	=	
5	168 608-3	=	
6	168 610-1	=	
7	168 704	=	0,1 - 3,5 bar
	302 507	=	3,5 - 21 bar
8	229 665	=	

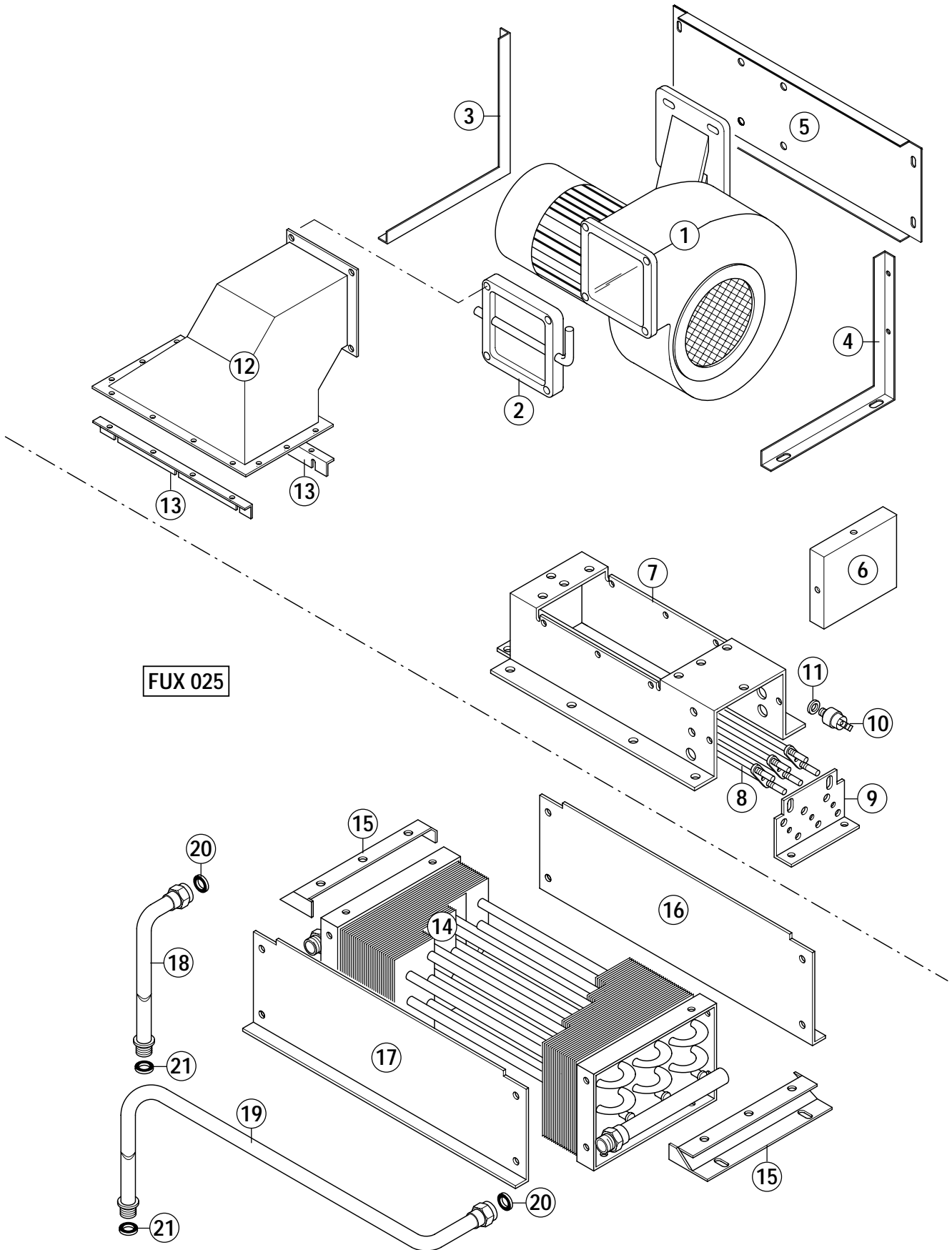



A conveyor width
largeur du convoyeur
Bandbreite
bandbreedte

B usable height
hauteur de passage
Durchlaufhöhe
doorvoerhoogte

C Entry length
Longueur d'entrée
Zulauflänge
Toevoerlengte

Pos.	L/R G/D	R/L D/G	Specifications / Spécifications / Angaben / Opgaven
1	301 247-9	=	see wiring diagramme / voir schéma de câblage / siehe Schaltplan / zie elektrisch schema
2	301 246	=	
3	301 244	301 245	
4	301 245	301 244	
5	301 243	=	A = 612 mm
	375 288-4	=	A = 965 mm
6	229 266	=	
7	697 772-1	=	A = 612 mm
	697 772-2	=	A = 965 mm
8	229 189-1	=	see wiring diagramme / voir schéma de câblage / siehe Schaltplan / zie elektrisch schema
9	229 265	=	6 + 9 kW
	697 775-1	=	12 + 18 kW
10	227 743-3	=	
11	602 501	=	
12	301 236-1	=	A = 612 mm
	780 290-1	=	A = 965 mm
13	301 241	=	A = 612 mm
	302 887	=	A = 965 mm
14	229 742	=	A = 612 mm
	230 459	=	A = 965 mm
15	301 242	=	
16	229 755	=	A = 612 mm
	230 482	=	A = 965 mm
17	229 755	=	A = 612 mm
	230 482	=	A = 965 mm
18	229 749-1	229 748-1	B = 440 mm
	229 749-2	229 748-2	B = 683 mm
19	229 747-1	229 746-1	A = 612 mm / B = 440 mm
	229 747-2	229 746-2	A = 612 mm / B = 683 mm
	300 923	300 921	A = 965 mm / B = 440 mm
	?	=	A = 965 mm / B = 683 mm
20	300 084-6	=	
21	168 611-15	=	

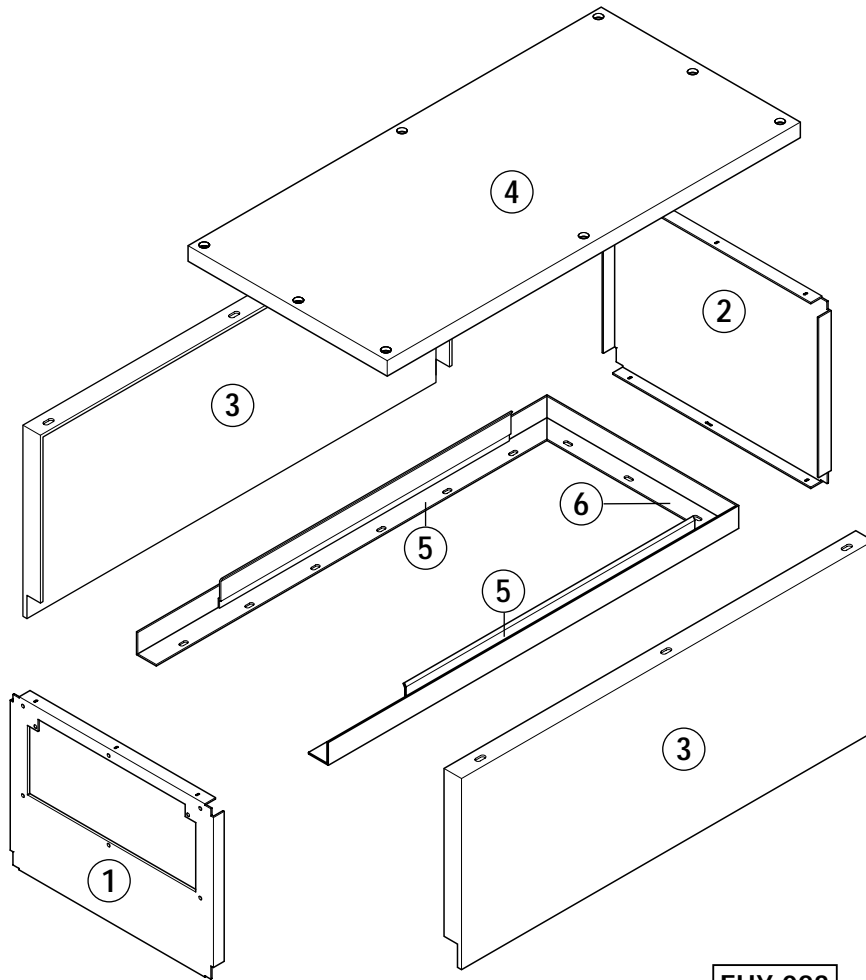
**FUX 023**



A conveyor width
largeur du convoyeur
Bandbreite
bandbreedte

B usable height
hauteur de passage
Durchlaufhöhe
doorvoerhoogte

C Entry length
Longueur d'entrée
Zulauflänge
Toevoerlengte

Pos.	L/R G/D	R/L D/G	Specifications / Spécifications / Angaben / Opgaven
1	229 287-2	=	A = 612 mm
	230 401-2	=	A = 965 mm
2	229 287-1	=	A = 612 mm
	230 401-1	=	A = 965 mm
3	229 440-2	=	D2A
	229 440-6	=	D2
4	300 532	=	A = 612 mm D2
	?	=	A = 965 mm D2
	229 286	=	A = 612 mm D2A
	230 466	=	A = 965 mm D2A
5	229 284	=	D2A
	303 527	=	D2
6	229 565	=	A = 612 mm
	230 464	=	A = 965 mm

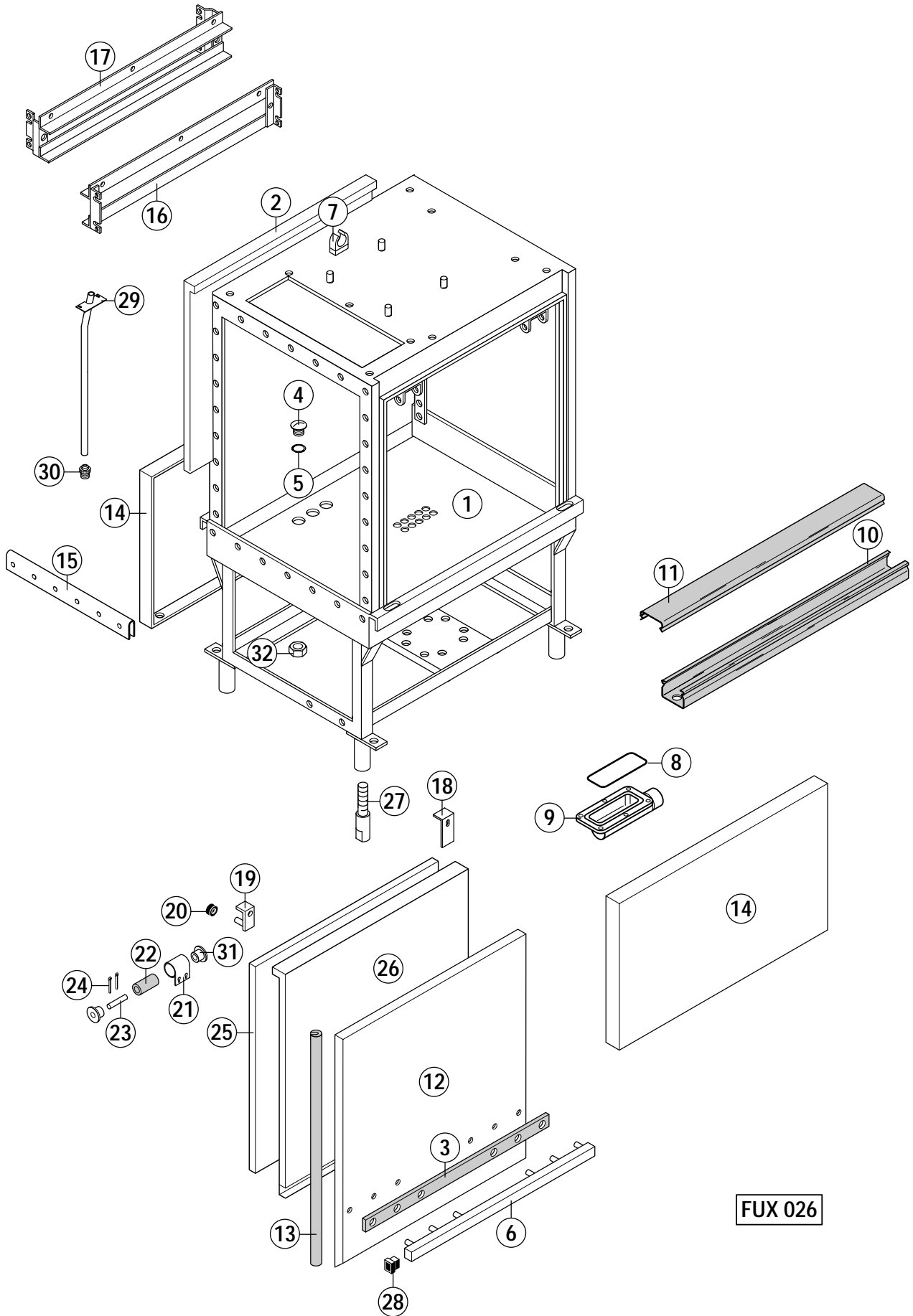

FUX 026



A conveyor width
largeur du convoyeur
Bandbreite
bandbreedte

B usable height
hauteur de passage
Durchlaufhöhe
doorvoerhoogte

C Entry length
Longueur d'entrée
Zulauflänge
Toevoerlengte

Pos.	L/R G/D	R/L D/G	Specifications / Spécifications / Angaben / Opgaven
1	697 960-7	697 960-2	A = 612 mm / B = 440 mm
	697 960-8	697 960-9	A = 612 mm / B = 683 mm
	697 960-4	697 960-3	A = 965 mm / B = 440 mm
	697 960-6	697 960-5	A = 965 mm / B = 683 mm
2	230 508	=	B = 440 mm
	229 901	=	B = 683 mm
3	229 531-1	=	
4	229 729-1	=	
5	276 903-9	=	
6	229 532	=	
7	379 213-1	=	
8	276 903-35	=	
9	325 529-1	=	
10	229 553-1	=	
11	229 553-1	=	
12	229 132	=	B = 440 mm
	229 816	=	B = 683 mm
13	302 207-4	=	B = 440 mm
	302 207-6	=	B = 683 mm
14	229 204-1	=	
15	229 401	=	A = 612 mm
	230 310	=	A = 965 mm
16	229 216-1	229 215-1	
17	229 215-1	229 216-1	
18	303 517	=	
19	303 516	=	
20	774 714-1	=	
21	229 277	=	B = 440 mm without insulation / sans isolement / ohne Isolierung / zonder isolatie
	229 473	=	B = 683 mm without insulation / sans isolement / ohne Isolierung / zonder isolatie
	229 732	=	B = 440 mm with insulation / avec isolement / mit Isolierung / met isolatie
	229 473	=	B = 683 mm with insulation / avec isolement / mit Isolierung / met isolatie
22	173 481	=	
23	602 846	=	
24	602 886	=	
25	229 132	=	B = 440 mm
	229 816	=	B = 683 mm
26	374 712-2	=	B = 440 mm
	374 712-3	=	B = 683 mm
27	166 066-3	=	
28	229 532	=	
29	693 143-1	=	B = 440 mm
	693 143-2	=	B = 683 mm
30	229 278	=	
31	784 934-1	=	
32	169 045-5	=	

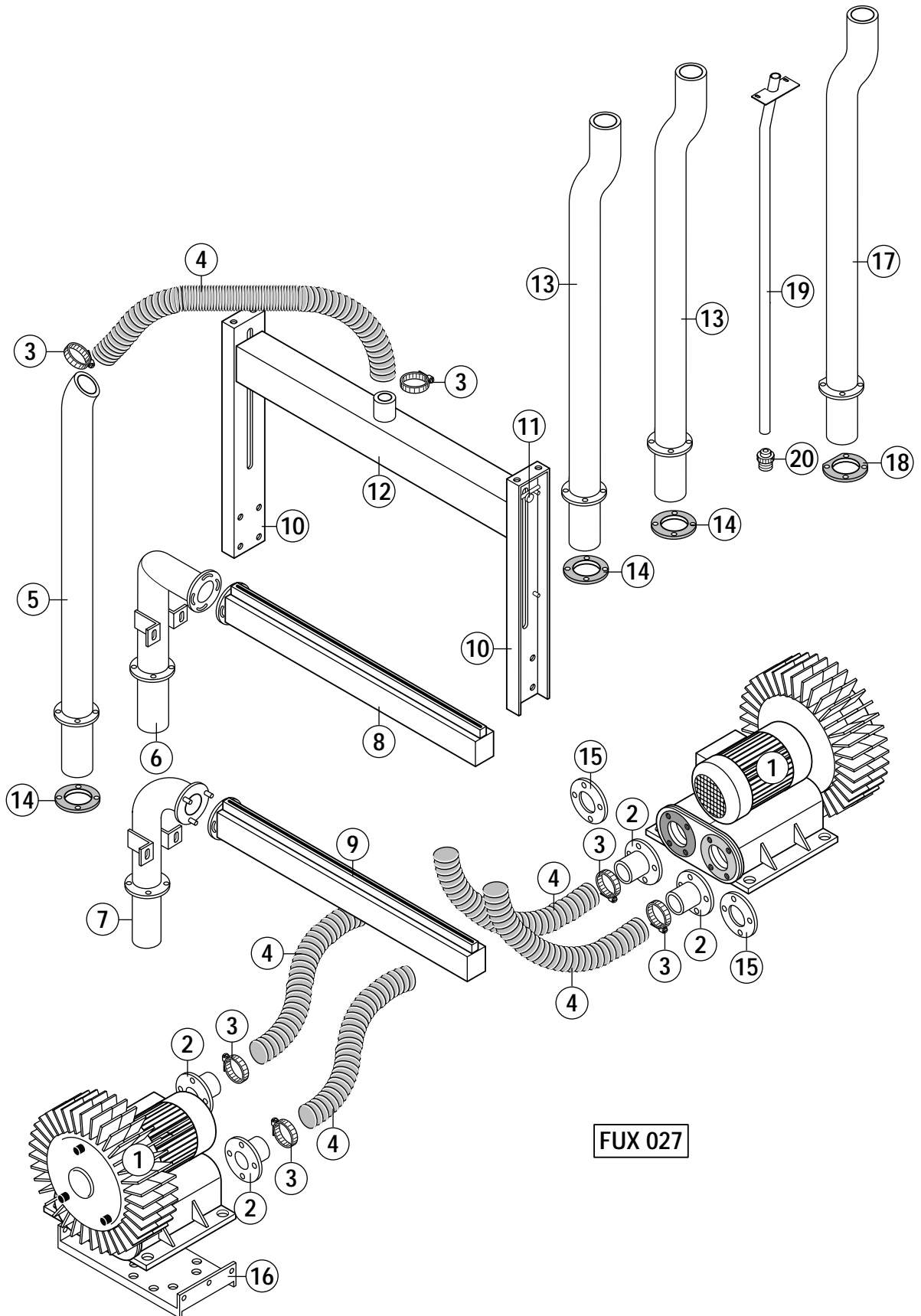

FUX 027



A conveyor width
largeur du convoyeur
Bandbreite
bandbreedte

B usable height
hauteur de passage
Durchlaufhöhe
doorvoerhoogte

C Entry length
Longueur d'entrée
Zulauflänge
Toevoerlengte

Pos.	L/R G/D	R/L D/G	Specifications / Spécifications / Angaben / Opgaven
1	736 921-1	=	see wiring diagramme / voir schéma de câblage / siehe Schaltplan / zie elektrisch schema
2	784 508-1	=	
3	869 038-1	=	
4	783 812-1	=	
5	782 214-1	=	B = 440 mm
	784 214-2	=	B = 683 mm
6	733 138-1	=	
7	781 517	=	
8	693 220-6	=	A = 612 mm
	693 220-7	=	A = 965 mm
9	693 220-4	=	A = 612 mm
	693 220-5	=	A = 965 mm
10	697 946-1	=	B = 440 mm
	697 946-2	=	B = 683 mm
11	735 821-1	=	A = 612 mm
	735 821-2	=	A = 965 mm
12	697 950-1	=	A = 612 mm
	697 950-2	=	A = 965 mm
13	731 566-1	=	B = 440 mm
	731 566-3	=	B = 683 mm
14	371 524	=	
15	784 507-1	=	
16	733 140-1	=	A = 612 mm
	733 140-3	=	A = 965 mm
17	731 566-10	=	B = 440 mm
	731 566-12	=	B = 683 mm
18	692 709-2	=	
19	693 143-3	=	B = 440 mm
	693 143-4	=	B = 683 mm
20	229 278	=	

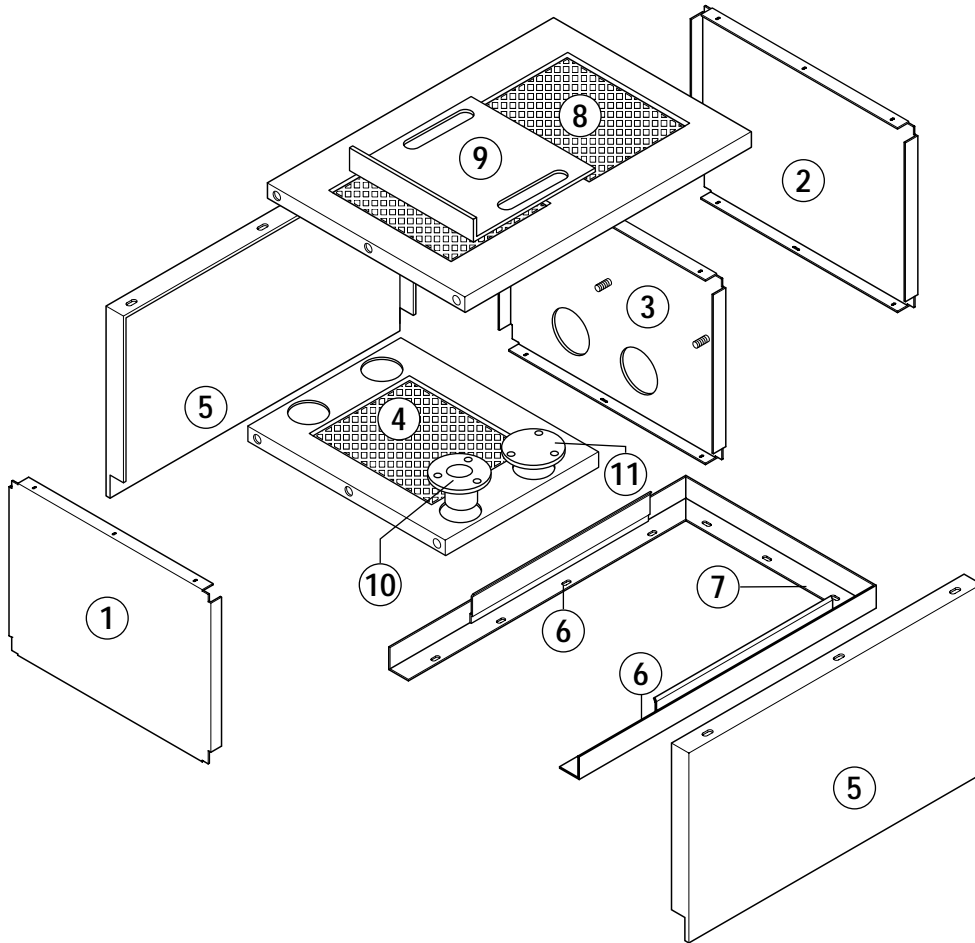
**FUX 028**



A conveyor width
largeur du convoyeur
Bandbreite
bandbreedte

B usable height
hauteur de passage
Durchlaufhöhe
doorvoerhoogte

C Entry length
Longueur d'entrée
Zulauflänge
Toevoerlengte

Pos.	L/R G/D	R/L D/G	Specifications / Spécifications / Angaben / Opgaven
1	229 287-1	=	A = 612 mm
	230 401-1	=	A = 965 mm
2	229 287-1	=	A = 612 mm
	230 401-1	=	A = 965 mm
3	784 940-1	=	A = 612 mm
	784 940-2	=	A = 965 mm
4	897 365-4	=	A = 612 mm
	897 365-3	=	A = 965 mm
5	229 440-6	=	
6	373 259-6	=	
7	229 565	=	A = 612 mm
	230 464	=	A = 965 mm
8	896 660-2	=	A = 612 mm
	896 660-3	=	A = 965 mm
9	897 369-1	=	A = 612 mm
	897 369-2	=	A = 965 mm
10	784 508-1	=	
11	884 558-1	=	

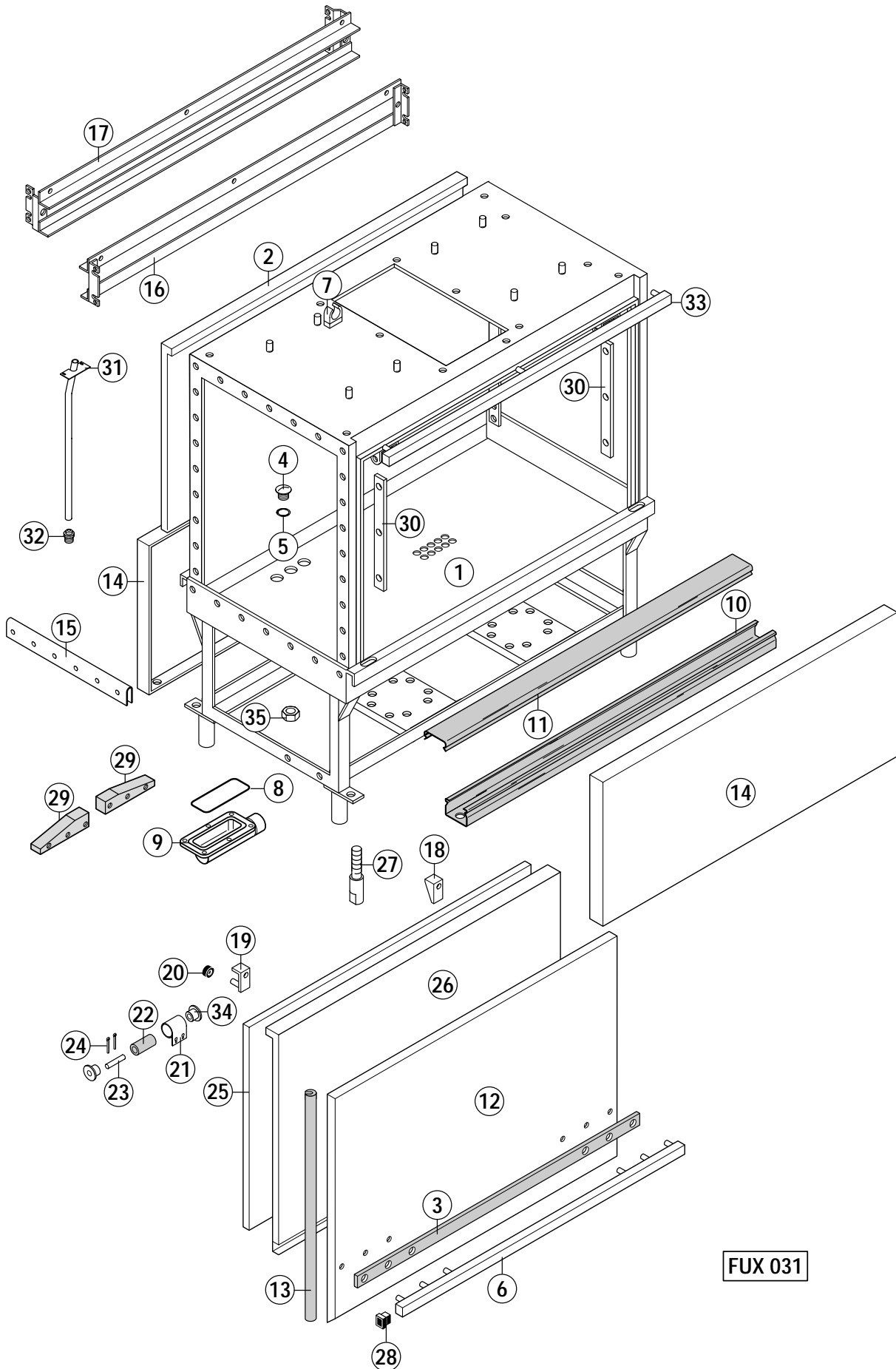

FUX 031



A conveyor width
largeur du convoyeur
Bandbreite
bandbreedte

B usable height
hauteur de passage
Durchlaufhöhe
doorvoerhoogte

C Entry length
Longueur d'entrée
Zulauflänge
Toevoerlengte

Pos.	L/R G/D	R/L D/G	Specifications / Spécifications / Angaben / Opgaven
1	698 691-1	=	A = 612 mm / B = 440 mm
	698 691-8	=	A = 612 mm / B = 683 mm
	698 691-3	=	A = 965 mm / B = 440 mm
	698 691-6	=	A = 965 mm / B = 683 mm
2	696 135-13	=	B = 440 mm
	696 135-14	=	B = 683 mm
3	374 898-2	=	
4	229 729-1	=	
5	276 903-9	=	
6	304 755-4	=	
7	379 213-1	=	
8	276 903-35	=	
9	325 529-1	=	
10	374 803-4	=	
11	374 804-4	=	
12	304 735-57	=	B = 440 mm
	304 735-55	=	B = 683 mm
13	302 207-4	=	B = 440 mm
	302 207-6	=	B = 683 mm
14	374 472-31	=	
15	229 401	=	A = 612 mm
	230 310	=	A = 965 mm
16	698 693-2	698 693-1	
17	698 694-2	698 694-1	
18	693 861-1	=	
19	692 861-1	=	
20	166 964	=	
21	230 072	=	B = 440 mm 1x (without insulation / sans isolation / ohne Isolierung / zonder isolatie)
	229 277	=	B = 440 mm 2x (without insulation / sans isolation / ohne Isolierung / zonder isolatie)
	229 473	=	B = 683 mm 3x (without insulation / sans isolation / ohne Isolierung / zonder isolatie)
	229 732	=	B = 440 mm 3x (with insulation / avec isolation / mit Isolierung / met isolatie)
	229 473	=	B = 683 mm 4x (with insulation / avec isolation / mit Isolierung / met isolatie)
22	173 481	=	
23	602 846	=	
24	602 886	=	
25	304 735-57	=	B = 440 mm
	304 735-55	=	B = 683 mm
26	374 712-9	=	B = 440 mm
	374 712-26	=	B = 683 mm
27	166 066-3	=	
28	229 532	=	
29	698 663-1	=	
30	780 785-3	=	B = 683 mm
31	693 143-1	=	B = 440 mm
	693 143-2	=	B = 683 mm
32	229 278	=	
33	731 560-2	=	
34	784 934-1	=	
35	169 045-5	=	

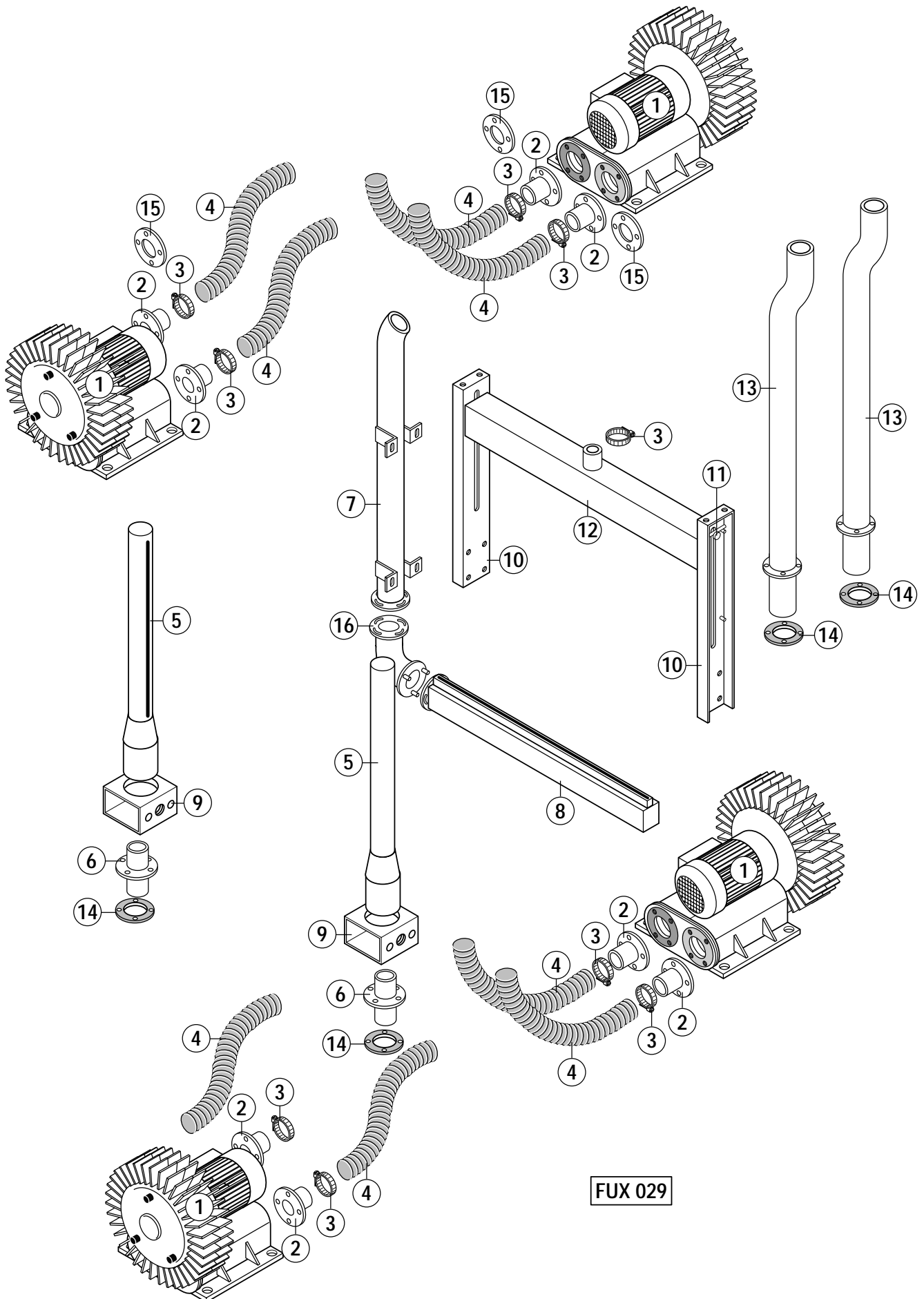



A conveyor width
 largeur du convoyeur
 Bandbreite
 bandbreedte

B usable height
 hauteur de passage
 Durchlaufhöhe
 doorvoerhoogte

C Entry length
 Longueur d'entrée
 Zulauflänge
 Toevoerlengte

Pos.	L/R G/D	R/L D/G	Specifications / Spécifications / Angaben / Opgaven
1	736 921-1	=	see wiring diagramme / voir schéma de câblage / siehe Schaltplan / zie elektrisch schema
2	784 508-1	=	
3	869 038-1	=	
4	783 812-1	=	
5	697 947-1	=	B = 440 mm
	697 947-1	=	B = 683 mm
6	697 955-1	=	
7	697 941-1	=	B = 440 mm
	697 941-2	=	B = 683 mm
8	693 220-6	=	A = 612 mm
	693 220-7	=	A = 965 mm
9	697 940-1	=	A = 612 mm
10	697 946-1	=	B = 440 mm
	697 946-2	=	B = 683 mm
11	735 821-1	=	A = 612 mm
	735 821-2	=	A = 965 mm
12	697 950-1	=	A = 612 mm
	697 950-2	=	A = 965 mm
13	731 566-1	=	B = 440 mm
	731 566-3	=	B = 683 mm
14	371 524	=	
15	784 507-1	=	
16	697 942-1	=	

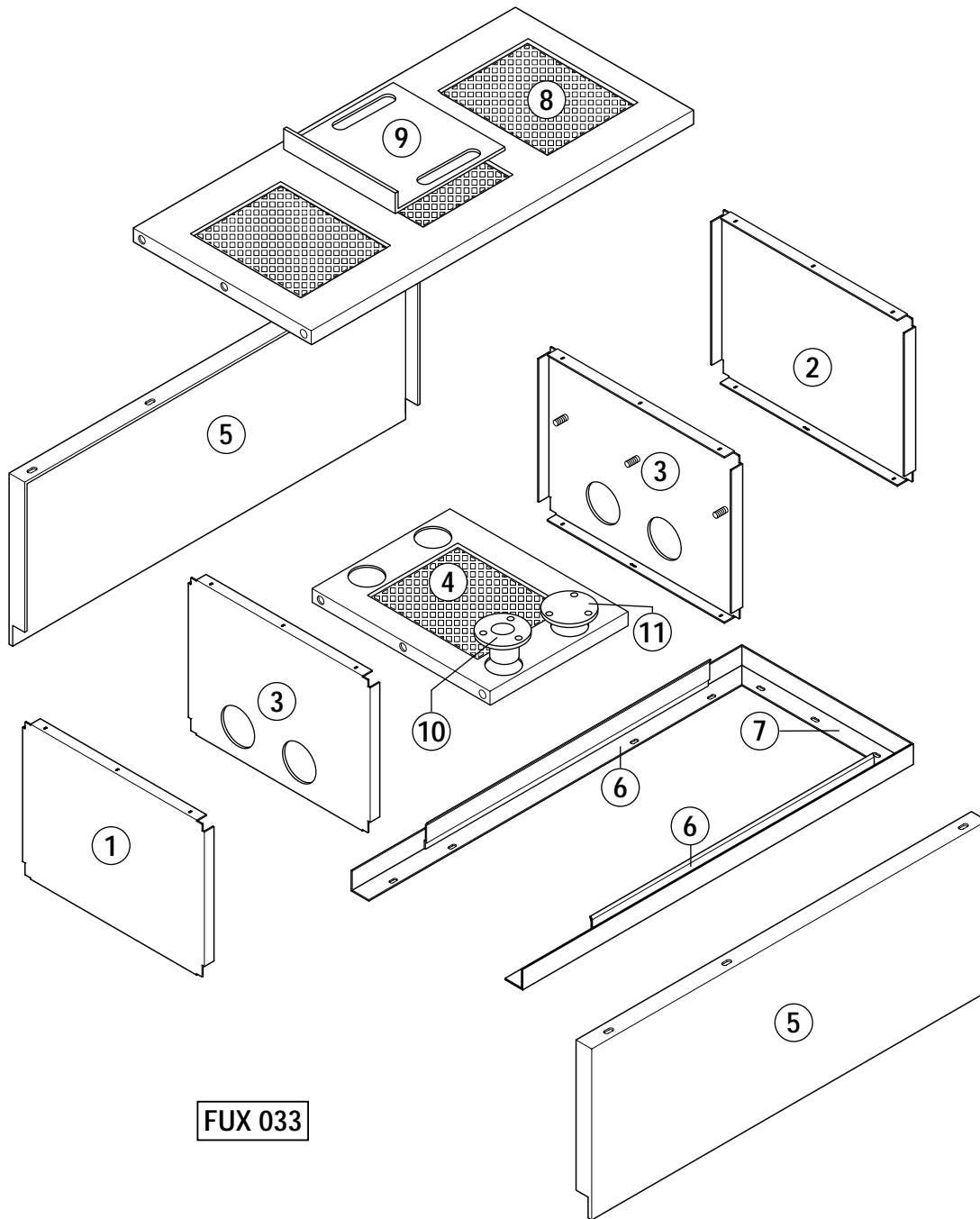
**FUX 033**



A conveyor width
 largeur du convoyeur
 Bandbreite
 bandbreedte

B usable height
 hauteur de passage
 Durchlaufhöhe
 doorvoerhoogte

C Entry length
 Longueur d'entrée
 Zulauflänge
 Toevoerlengte

Pos.	L/R G/D	R/L D/G	Specifications / Spécifications / Angaben / Opgaven
1	229 287-1	=	A = 612 mm
	230 401-1	=	A = 965 mm
2	229 287-1	=	A = 612 mm
	230 401-1	=	A = 965 mm
3	784 940-1	=	A = 612 mm
	784 940-2	=	A = 965 mm
4	897 365-2	=	A = 612 mm
	897 365-1	=	A = 965 mm
5	375 299-7	=	
6	375 259-11	=	
7	229 565	=	A = 612 mm
	230 464	=	A = 965 mm
8	896 660-4	=	A = 612 mm
	896 660-5	=	A = 965 mm
9	897 369-3	=	A = 612 mm
	897 369-4	=	A = 965 mm
10	784 508-1	=	
11	884 558-1	=	

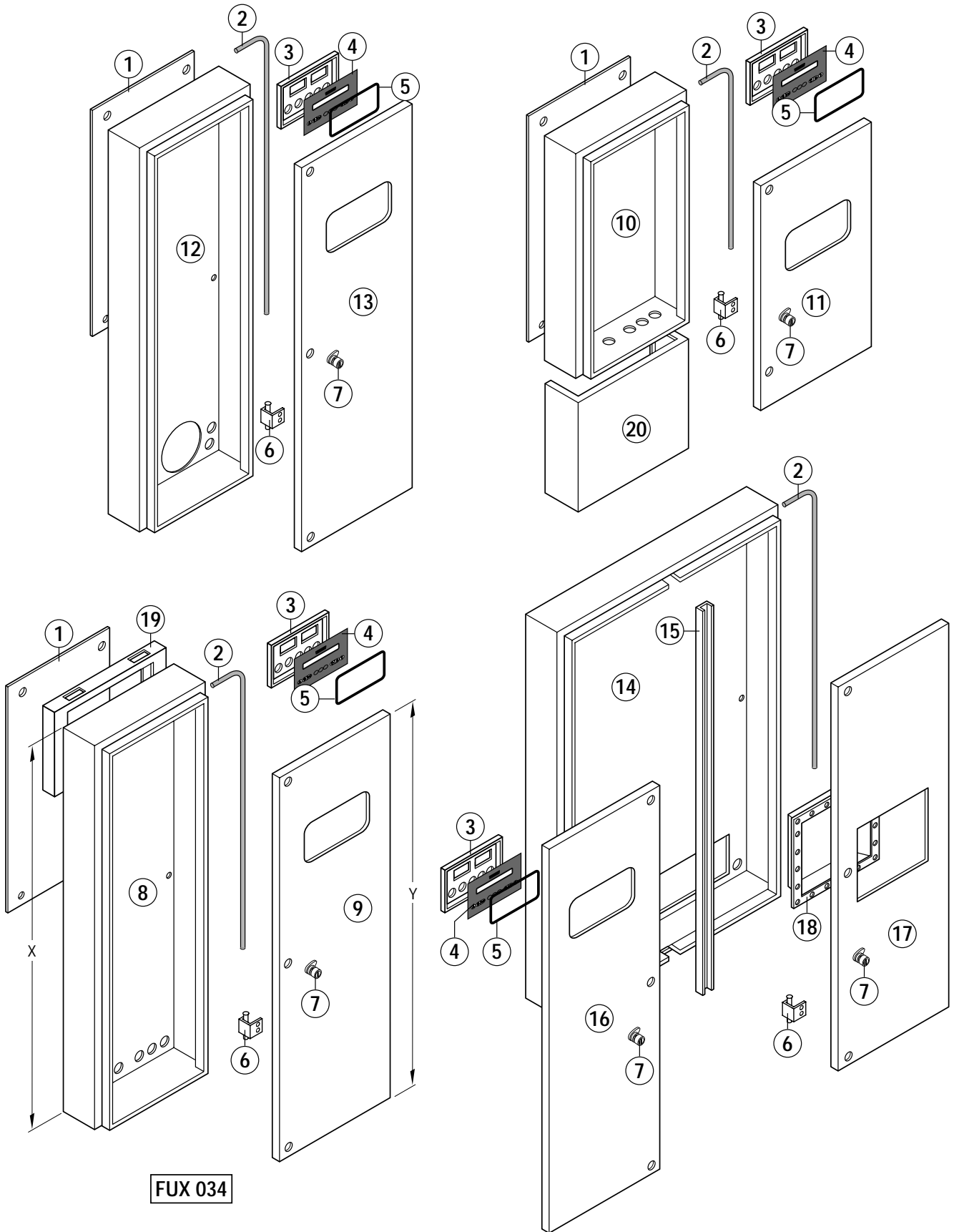



A conveyor width
largeur du convoyeur
Bandbreite
bandbreedte

B usable height
hauteur de passage
Durchlaufhöhe
doorvoerhoogte

C Entry length
Longueur d'entrée
Zulauflänge
Toevoerlengte

Pos.	L/R G/D	R/L D/G	Specifications / Spécifications / Angaben / Opgaven
1	297 566	=	
2	229 169	=	5 m
3	868 199-2	=	Standard
	896 395-1	=	Protronic+II
4	868 001-3	=	Standard
	896 376-1	=	Protronic+II
5	325 554-3	=	
6	229 209	=	
7	229 518-1	=	
8	897 278-1	=	X = 1 830
	897 279-1	=	X = 1 332
9	692 603-2	=	Y = 1 830
	692 603-4	=	Y = 1 332
10	782 266-1	=	
11	782 268-1	=	
12	782 264-1	=	
13	692 603-4	=	
14	782 488-1	=	
15	782 485-1	=	
16	782 498-3	=	
17	782 490-1	=	without main switch / sans interrupteur général / ohne Hauptschalter / zonder hoofdschakelaar
	782 490-2	=	with main switch / avec interrupteur général / mit Hauptschalter / met hoofdschakelaar
18	733 159-2	=	
19	899 728-1	=	
20	229 876	=	

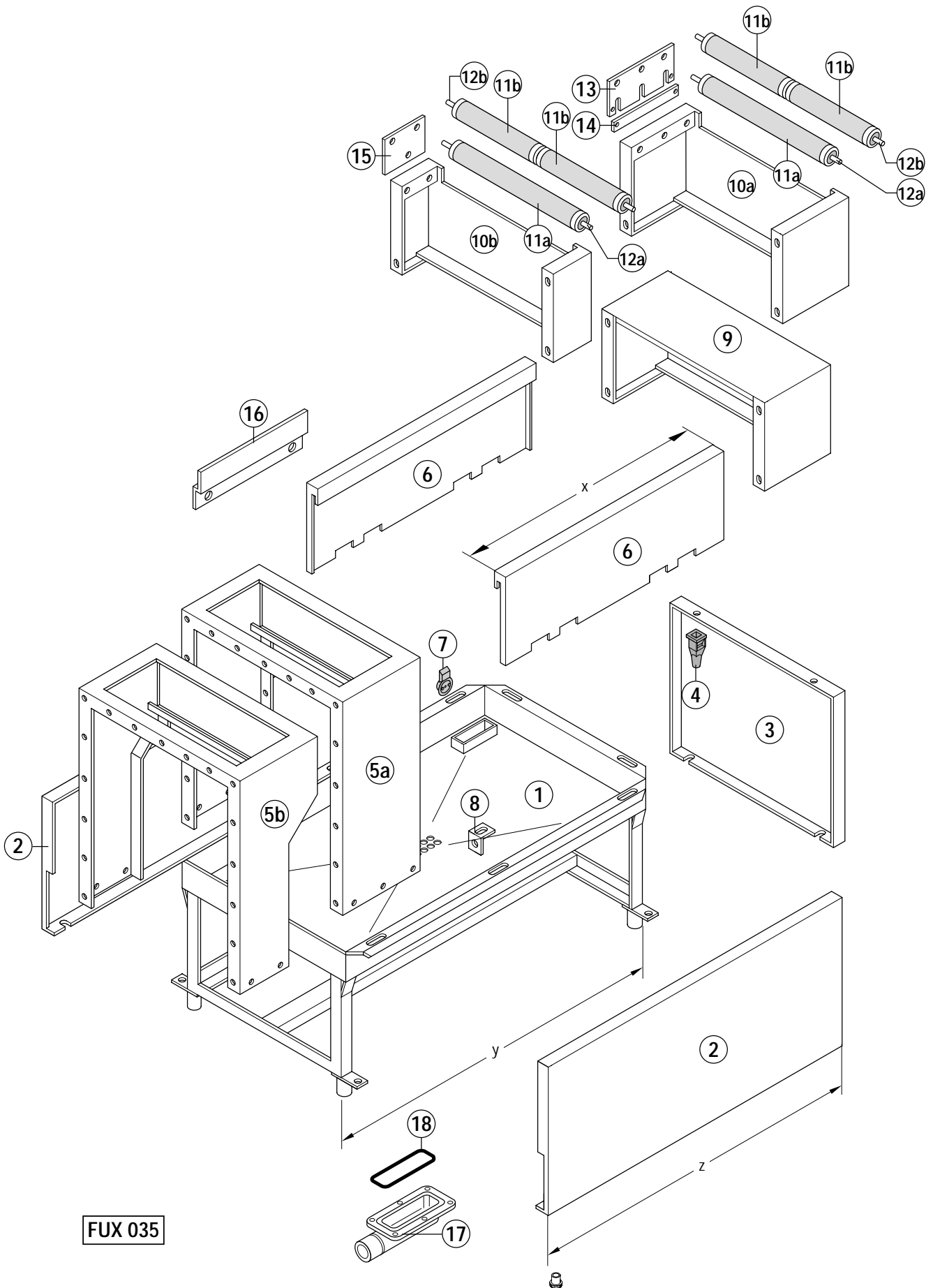

Pos.	L/R G/D	R/L D/G	Specifications / Spécifications / Angaben / Opgaven
1	697 708-1	=	A = 612 mm (y = 500 mm)
	229 352-1	=	A = 612 mm (y = 900 mm)
	229 352-2	=	A = 612 mm (y = 1 200 mm)
	229 352-3	=	A = 612 mm (y = 1 500 mm)
	697 708-2	=	A = 965 mm (y = 500 mm)
	229 948-1	=	A = 965 mm (y = 900 mm)
	229 948-2	=	A = 965 mm (y = 1 200 mm)
	229 948-3	=	A = 965 mm (y = 1 500 mm)
2	229 204-11	=	A = 612 mm (z = 500 mm)
	229 204-1	=	A = 612 mm (z = 900 mm)
	229 204-3	=	A = 612 mm (z = 1 200 mm)
	229 204-4	=	A = 612 mm (z = 1 500 mm)
3	229 344	=	A = 612 mm
	229 944	=	A = 965 mm
4	102 312	=	
5a	229 405	=	A = 612 mm / B = 440 mm
	229 814	=	A = 612 mm / B = 683 mm
	229 957	=	A = 965 mm / B = 440 mm
	230 618	=	A = 965 mm / B = 683 mm
5b	697 710-1	=	A = 612 mm / B = 440 mm
	697 710-3	=	A = 612 mm / B = 683 mm
	697 710-2	=	A = 965 mm / B = 440 mm
	697 710-5	=	A = 965 mm / B = 683 mm
6	229 335-1	=	(x = 538 mm)
	229 335-2	=	(x = 838 mm)
	229 335-3	=	(x = 1 138 mm)
	229 335-6	=	(x = 1 438 mm)
	229 335-12	=	(x = 458 mm)
	229 335-4	=	(x = 368 mm)
	229 335-11	=	(x = 288 mm)
	229 335-5	=	(x = 668 mm)
7	325 037-1	=	
8	229 445	=	
9	229 339	=	A = 612 mm
	229 970	=	A = 965 mm
10a	733 908-1	=	A = 612 mm
	733 908-2	=	A = 965 mm
10b	698 635-1	=	A = 612 mm
	698 635-2	=	A = 965 mm
11a	303 519-7	=	A = 612 mm
11b	303 519-8	=	A = 965 mm
12a	698 095-5	=	A = 612 mm
12b	698 095-4	=	A = 965 mm
13	733 911-1	=	
14	733 909-1	=	
15	698 636-1	=	
16	229 554-6	=	only with pos. 5b / seulement avec pos. 5b / nur bei Pos. 5b / maar bij pos. 5b
17	325 529-1	=	
18	276 903-35	=	

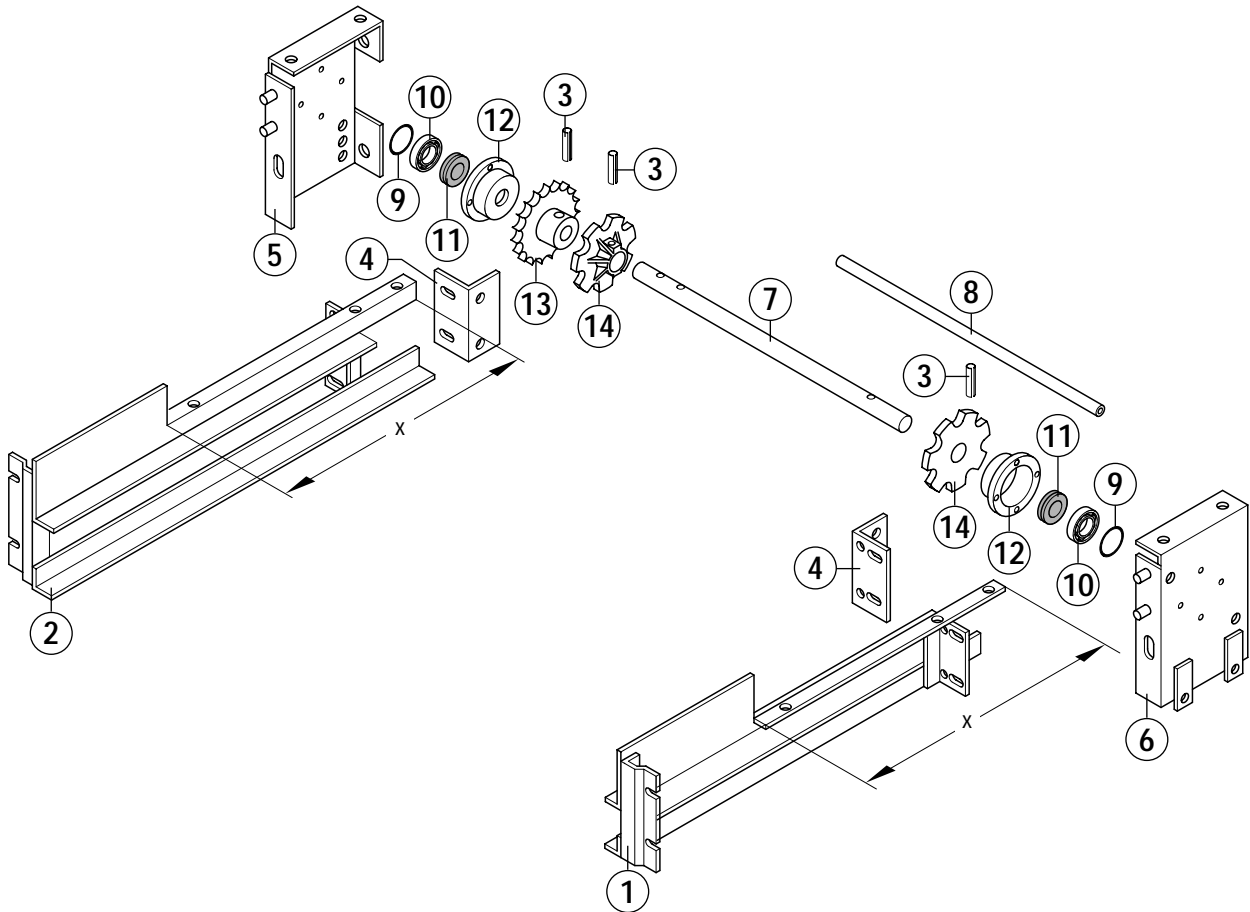

FUX 036

Pos.	L/R G/D	R/L D/G	Specifications / Spécifications / Angaben / Opgaven
1	379 530-4	379 531-6	x = 436 mm (without hood / sans capot / ohne Haube / zonder behuizing)
	229 311-9	229 312-9	x = 295 mm (with hood / avec capot / mit Haube / met behuizing)
	379 530-1	379 531-1	x = 842 mm (without hood / sans capot / ohne Haube / zonder behuizing)
	229 311-1	229 312-1	x = 542 mm (with hood / avec capot / mit Haube / met behuizing)
	379 530-2	379 531-2	x = 1 142 mm (without hood / sans capot / ohne Haube / zonder behuizing)
	229 311-2	229 312-2	x = 842 mm (with hood / avec capot / mit Haube / met behuizing)
	379 530-3	379 531-3	x = 1 142 mm (without hood / sans capot / ohne Haube / zonder behuizing)
	229 311-3	229 312-3	x = 1 142 mm (with hood / avec capot / mit Haube / met behuizing)
2	379 531-6	379 530-4	x = 436 mm (without hood / sans capot / ohne Haube / zonder behuizing)
	229 312-9	229 311-9	x = 295 mm (with hood / avec capot / mit Haube / met behuizing)
	379 531-1	379 530-1	x = 842 mm (without hood / sans capot / ohne Haube / zonder behuizing)
	229 312-1	229 311-1	x = 542 mm (with hood / avec capot / mit Haube / met behuizing)
	379 531-2	379 530-2	x = 1 142 mm (without hood / sans capot / ohne Haube / zonder behuizing)
	229 312-2	229 311-2	x = 842 mm (with hood / avec capot / mit Haube / met behuizing)
	379 531-3	379 530-3	x = 1 142 mm (without hood / sans capot / ohne Haube / zonder behuizing)
	229 312-3	229 311-3	x = 1 142 mm (with hood / avec capot / mit Haube / met behuizing)
3	602 849	=	
4	229 543	=	
5	229 463	229 464	
6	229 464	229 463	
7	229 248	=	A = 612 mm
	229 959	=	A = 965 mm
8	229 263-1	=	A = 612 mm
	229 263-7	=	A = 965 mm
9	229 239	=	
10	602 748	=	
11	229 552-1	=	
12	229 236	=	
13	168 828	=	
	303 587	=	(sst / inox / CrNi)
14	229 240	=	
	303 598	=	(sst / inox / CrNi)

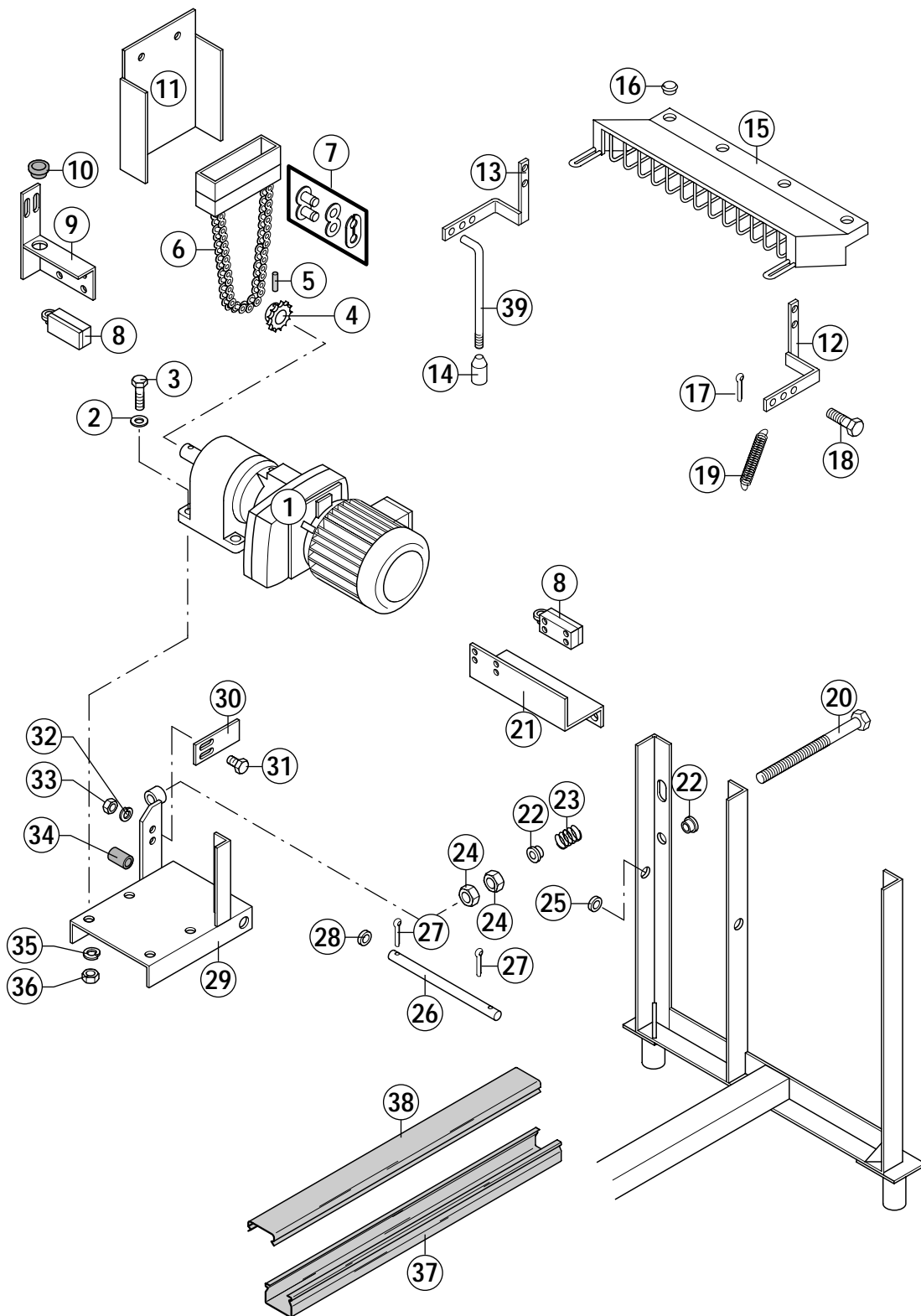
**FUX 037**



A conveyor width
largeur du convoyeur
Bandbreite
bandbreedte

B usable height
hauteur de passage
Durchlaufhöhe
doorvoerhoogte

C Entry length
Longueur d'entrée
Zulauflänge
Toevoerlengte

Pos.	L/R G/D	R/L D/G	Specifications / Spécifications / Angaben / Opgaven
1	697 724-1	=	see wiring diagramme / voir schéma de câblage / siehe Schaltplan / zie elektrisch schema
2	602 287	=	
3	602 576	=	
4	229 371	=	
5	602 887	=	
6	168 703-3	=	
7	226 485	=	
8	226 916	=	see wiring diagramme / voir schéma de câblage / siehe Schaltplan / zie elektrisch schema
9	229 365	=	
10	229 545	=	
11	300 537	=	
12	229 360	229 361	
13	229 361	229 360	
14	229 369	=	
15	229 455	=	A = 612 mm
	229 973	=	A = 965 mm
16	228 828	=	
17	602 883	=	
18	229 362-1	=	
19	228 289	=	
20	602 693	=	
21	229 550	=	
22	229 413	=	
23	227 873-6	=	
24	602 503	=	
25	602 289	=	
26	229 372	=	
27	602 884	=	
28	602 289	=	
29	692 772-2	=	
30	229 549	=	
31	602 567	=	
32	602 306	=	
33	602 501	=	
34	165 136-4	=	
35	602 305	=	
36	602 492	=	
37	229 553	=	
38	229 561	=	
39	229 366	=	

As continued product improvement is a policy of HOBART, specifications are subject to change without notice.

Ce catalogue n'est pas contractuel. HOBART se réserve le droit, et sans préavis, d'apporter toutes modifications ou améliorations à ses matériels.

HOBART behält sich das Recht vor, an allen Produkten technische Änderungen und Verbesserungen ohne Ankündigung vorzunehmen.

Voortdurende produktverbetering vormt een wezenlijk onderdeel van het beleid van HOBART. Specificaties kunnen zonder kennisgeving gewijzigd worden.