

NO. E1AM-1855

ISSUED: OCT.1999

REVISED: FEB.2009

SERVICE INFORMATION



HOSHIZAKI SELF-CONTAINED CUBER

**MODEL IM-100LE
IM-100LE-21
IM-100LE-23**

PARTS LIST

[HE, GENERAL (50Hz), OCEANIA, RINNAI, KOREA, EXPORT (60Hz), AUSTRALIA, HSP]

F-1	JUN.	1996	E-0	DEC.	2004
G-0	DEC.	1996	E-1	APR.	2005
H-0	DEC.	1997	R-0	DEC.	2005
H-1	MAR.	1998	S-0	JAN.	2007
J-0	DEC.	1998	S-1	MAY.	2007
K-0	DEC.	1999	S-2	DEC.	2007
A-0	DEC.	2000	T-0	JAN.	2008
B-0	DEC.	2001	T-1	JUL.	2008
C-0	DEC.	2002	U-0	JAN.	2009
D-0	DEC.	2003			
D-1	NOV.	2004			

MATERIAL ABBREVIATIONS

ALUMINUM

AL = Aluminum

COPPER

CU = Copper

PLASTIC

ABS = Acrylonitrile -butadiene - styrene
AC = Polyacetal
EVA = Ethylene vinyl acetate
PA = Polyamide = Nylon
PC = Polycarbonate
PE = Polyethylene
PES = Polyester
PETP = Polyethylene terephthalate = Tetlon
PP = Polypropylene
PS = Polystyrene
PTFE = Polytetrafluoroethylene = Teflon
PUR = Polyurethane
PVC = Polyvinyl chloride

RUBBER

VN = Vinyl Nitrile
EPDM = EP rubber
NBR = Nitrile butadiene rubber
NR = Natural rubber
NP = Neoprene
SI.R = Silicone rubber
SY.R = Synthetic rubber
EPH = Epichlorohydrin

STEEL

GS = Galvanized steel
SS = Stainless steel
PS = Plated steel
PAS = Primed steel

AUXILIARY CODE

K-0

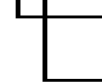

Designates the year. "K" indicates the year 2000. Years progress or regress in alphabetical order. "J" is 1999, "L" is 2001, "M" is 2002, and so on. The letters "I" and "O" were skipped.

Designates significant part changes within the same year. Base is 0 and this number advances for each change.

Example: P-1



"P" indicates 2004.

"1" indicates the first significant part change for 2004.

MARKS LOCATED UNDER THE AUXILIARY CODE

- = Part deleted.
- x = Part deleted and replaced by "o" part.
- o = New part in place of "x" part.

FASTENER ABBREVIATION LIST

ST	=	Phillips Truss Head Machine Screw
SP	=	Phillips Pan Head Machine Screw
SF	=	Phillips Flat Head Machine Screw
SS	=	Phillips Pan Head Machine Screw with Split Lock Washer
SW	=	Phillips Pan Head Machine Screw with Split Lock Washer and Flat Washer
T1	=	Phillips Truss Head Tapping Screw (Correspond to Type A)
T2	=	Phillips Truss Head Tapping Screw (Correspond to Type B)
T3	=	Phillips Truss Head Tapping Screw (Correspond to Type C)
FT	=	Phillips Truss Head Tapping Screw (Special)
BH	=	Hexagon Head Bolt
BC	=	Socket Head Cap Screw
BS	=	Hexagon Bolt with Split Washer
BW	=	Hexagon Bolt with Split Washer and Flat Washer
BF	=	Hexagon Flange Bolt
BR	=	Cross-Recessed Hexagon Head Bolt
BRW	=	Cross-Recessed Hexagon Head Bolt with Split Lock Washer and Flat Washer
WL	=	Split Lock Washer
WT	=	External Tooth Washer
WF	=	Flat Washer
WS	=	Spring Washer
NH	=	Hexagon Nut
NF	=	Hexagon Flange Nut
NC	=	Hexagon Cap Nut
NS	=	Square Nut
NW	=	Wing Nut

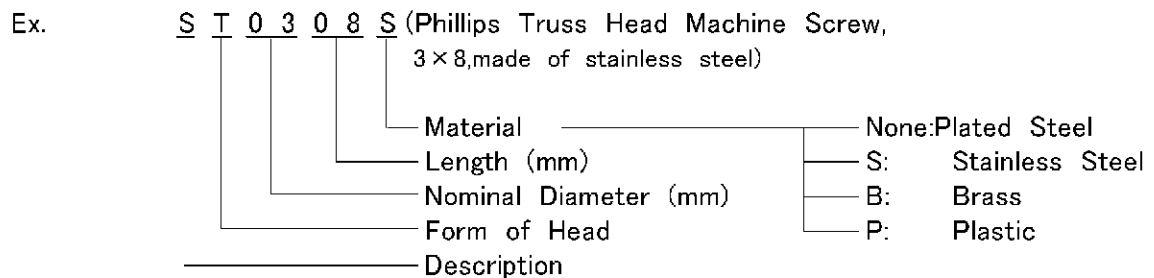

(Note) Second character is numerical except the list.
 Ex: S1,S2,B3 etc.

And abbreviations and names are shown under the illustration.

IM-100LE
 IM-100LE-23,-21

A. ICE CUBER ASSY

(E-1) and later
 (C-0) (D-0) (D-1) (E-0)
 (J-0) (K-0) (A-0) (B-0)
 (F-1) (G-0) (H-0) (H-1)

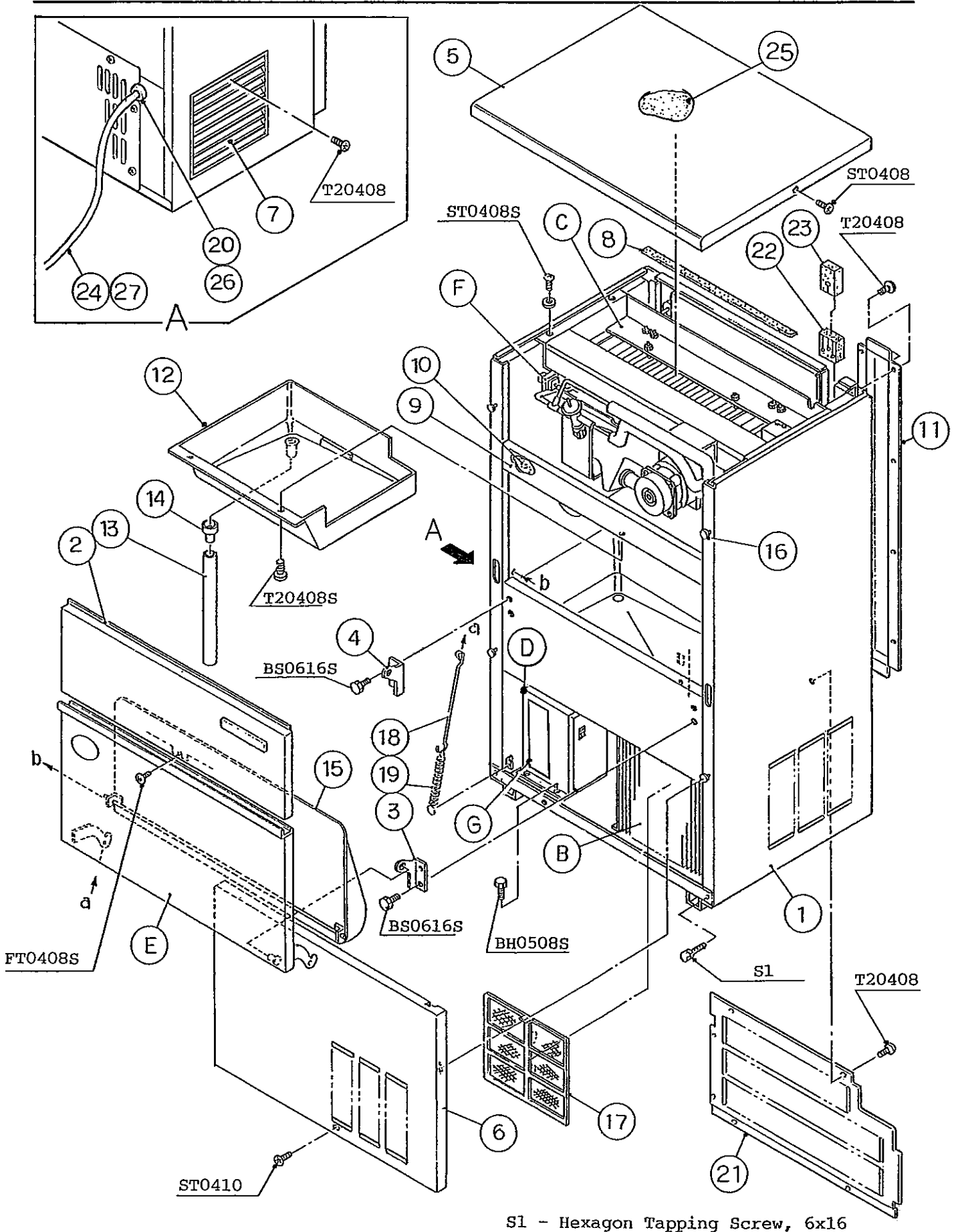

S1 - Hexagon Tapping Screw, 6x16

HE,GENERAL,EXPORT,OCEANIA,RINNAI,KOREA,AUSTRALIA,HSP

MODEL : IM-100LE							
IM-100LE-21,-23			TITLE : A. ICE CUBER ASSY				
INDEX NO.	DESCRIPTION	MATERIAL OR MODEL NUMBER	PART NUMBER	REQ'D NUMBER			
				F-1 G-0 H-0	H-1 J-0 K-0 A-0 B-0 C-0 D-0	D-1 E-0	E-1 R-0 S-0
B	REFRIGERATION ASSY	(100LE)	1H1519A01	1	1	1	1
	REFRIGERATION ASSY	(100LE-21,-23)	-	1	1	1	1
C	ICE MAKING MECHANISM ASSY	(100LE)	1H0268A05	1	1	1	1
	ICE MAKING MECHANISM ASSY	(100LE-21,-23)	-	1	1	1	1
D	CONTROL BOX ASSY	-	2H3234A01	1	-		
		-	2H3619A01		1	-	
		-	2H3619A03			1	-
		-	2H6792A01				1
E	DOOR ASSY	-	3H1420A07	1	1	1	1
		-	3Y2909A01				
		-	3Y3817A01				
F	WATER CIRCUIT ASSY	-	3H9588A01	1	1	1	1
G	LABEL LOCATION	(100LE)	3H9564A01	1	-		
			3X1500A01		1	1	-
			3X1500A03				1
	LABEL LOCATION	(100LE-21,-23)	-	1	1	1	1
1	UNIT BODY	-	1H1259G01	1	1	1	1
		-	1H1259G03				
2	FRONT PANEL (UPPER)	S.S	3H8109G04	1	1	1	1
	FRONT PANEL (UPPER)	(RINNAI)	3H8109G08	1	1×		
3	HINGE (RIGHT)	S.S	4H2583-01	1	1	1	1
4	HINGE (LEFT)	S.S	4H2584-01	1	1	1	1
5	TOP PANEL	S.S	3H9607-01	1	1	1	1
6	FRONT PANEL (LOWER)	S.S	2H3212-01	1	1	1	1
7	LOUVER	ABS	101812-09	1	1	1	1
8	SOFT TAPE	t3 x 15 x 700	1H1518-45	1	1	1	1
9	FRONT FRAME	S.S	3H7761-04	1	1	1	1
10	INSULATION - FRONT FRAME	PE	4H2687-01	1	1	1	1
11	COVER - PIPE	G.S	3H1436-01	1	1	1	1
12	DRAIN PAN	ABS	2H1935G01	1	1	1	1
13	PIPE - DRAIN	ABS	4H2688-01	1	1	1	1
14	DRAIN TUBE	SI	4H2585-01	1	1	1	1

HE,GENERAL,EXPORT,OCEANIA,RINNAI,KOREA,AUSTRALIA,HSP

MODEL : IM-100LE							
IM-100LE-21,-23				TITLE : A. ICE CUBER ASSY			
INDEX NO.	DESCRIPTION	MATERIAL OR MODEL NUMBER	PART NUMBER	REQ'D NUMBER			
				S-1	S-2 T-0	T-1 U-0	
B	REFRIGERATION ASSY	(100LE)	1H1519A01	1	1	1	
	REFRIGERATION ASSY	(100LE-21,-23)	-	1	1	1	
C	ICE MAKING MECHANISM ASSY	(100LE)	1H0268A05	1	1	1	
	ICE MAKING MECHANISM ASSY	(100LE-21,-23)	-	1	1	1	
D	CONTROL BOX ASSY	-	-				
		-	-				
		-	-				
		-	2H6792A01	1	1	1	
E	DOOR ASSY	-	3H1420A07	1	-		
		-	3Y2909A01		1	-	
		-	3Y3817A01			1	
F	WATER CIRCUIT ASSY	-	3H9588A01	1	1	1	
G	LABEL LOCATION	(100LE)	-				
			-				
			3X1500A03	1	1	1	
	LABEL LOCATION	(100LE-21,-23)	-	1	1	1	
1	UNIT BODY	-	1H1259G01	-			
		-	1H1259G03	1	1	1	
2	FRONT PANEL (UPPER)	S.S	3H8109G04	1	1	1	
	FRONT PANEL (UPPER)	-	-				
3	HINGE (RIGHT)	S.S	4H2583-01	1	1	1	
4	HINGE (LEFT)	S.S	4H2584-01	1	1	1	
5	TOP PANEL	S.S	3H9607-01	1	1	1	
6	FRONT PANEL (LOWER)	S.S	2H3212-01	1	1	1	
7	LOUVER	ABS	101812-09	1	1	1	
8	SOFT TAPE	t3 x 15 x 700	1H1518-45	1	1	1	
9	FRONT FRAME	S.S	3H7761-04	1	1	1	
10	INSULATION - FRONT FRAME	PE	4H2687-01	1	1	1	
11	COVER - PIPE	G.S	3H1436-01	1	1	1	
12	DRAIN PAN	ABS	2H1935G01	1	1	1	
13	PIPE - DRAIN	ABS	4H2688-01	1	1	1	
14	DRAIN TUBE	SI	4H2585-01	1	1	1	

HE,GENERAL,EXPORT,OCEANIA,RINNAI,KOREA,AUSTRALIA,HSP

MODEL : IM-100LE							
IM-100LE-21,-23			TITLE : A. ICE CUBER ASSY				
INDEX NO.	DESCRIPTION	MATERIAL OR MODEL NUMBER	PART NUMBER	REQ'D NUMBER			
				F-1 G-0 H-0	H-1 J-0 K-0 A-0 B-0 C-0 D-0	D-1 E-0	E-1 R-0 S-0
15	SLOPE	ABS	3H1452G01	1	1	1	1
16	TAPER COLLAR	S.S	4H0171-01	4	4	4	4
17	AIR FILTER	PP	332631G01	1	1	1	1
18	HOOK	S.S	4H2685-01	1	1	1	1
19	SPRING	ZINC-PLATED WIRE	4H0823-01	1	1	1	1
20	BUSHING	CEE-SR-6P-10	448949-01	1	1	1	1
21	REAR PANEL	S.S	3H9610-01	1	1	1	1
22	INSULATION (A)	PE	4H2683-01	1	1	1	1
23	INSULATION (B)	PE	4X5297-01	1	1	1	1
24	POWER SUPPLY CORD (CONTINENTAL)	(HE) (EXPORT) (KOREA)	452263-01	1	1	1	1
	POWER CORD (UK)	(HE) (GENERAL) (HSP)	4X3521G01	1	1	1	1
	POWER CORD	(OCEANIA)	4X3520G01	1	1	1	1
	POWER CORD	(RINNAI) (AUSTRALIA)	458139-01	1	1	1	1
25	INSULATION - TOP PANEL	PS	3H9602-01	1	1	1	1

HE,GENERAL,EXPORT,OCEANIA,RINNAI,KOREA,AUSTRALIA,HSP

MODEL : IM-100LE							
IM-100LE-21,-23			TITLE : A. ICE CUBER ASSY				
INDEX NO.	DESCRIPTION	MATERIAL OR MODEL NUMBER	PART NUMBER	REQ'D NUMBER			
				S-1	S-2 T-0	T-1 U-0	
15	SLOPE	ABS	3H1452G01	1	1	1	
16	TAPER COLLAR	S.S	4H0171-01	4	4	4	
17	AIR FILTER	PP	332631G01	1	1	1	
18	HOOK	S.S	4H2685-01	1	1	1	
19	SPRING	ZINC-PLATED WIRE	4H0823-01	1	1	1	
20	BUSHING	CEE-SR-6P-10	448949-01	×			
21	REAR PANEL	S.S	3H9610-01	1	1	1	
22	INSULATION (A)	PE	4H2683-01	1	1	1	
23	INSULATION (B)	PE	4X5297-01	1	1	1	
24	POWER SUPPLY CORD (CONTINENTAL)	(HE) (EXPORT) (KOREA)	452263-01	×			
	POWER CORD (UK)	(HE) (GENERAL) (HSP)	4X3521G01	×			
	POWER CORD	(OCEANIA)	4X3520G01	×			
	POWER CORD	(RINNAI) (AUSTRALIA)	458139-01	×			
25	INSULATION - TOP PANEL	PS	3H9602-01	1	1	1	
26	CONNECTOR	-	P00245-01	1	1	1	
27	POWER CORD	(CONTINENTAL)	P00240-01	1	1	1	
	POWER CORD (WITH UK PLUG)	(UK)	P00241-01	1	1	1	
	POWER CORD	(AUSTRALIA)	P00242-01	1	1	1	

IM-100LE
IM-100LE-23,-21

B. REFRIGERATION ASSY

(E-1) and later
(C-0) (D-0) (D-1) (E-0)
(J-0) (K-0) (A-0) (B-0)
(F-1) (G-0) (H-0) (H-1)

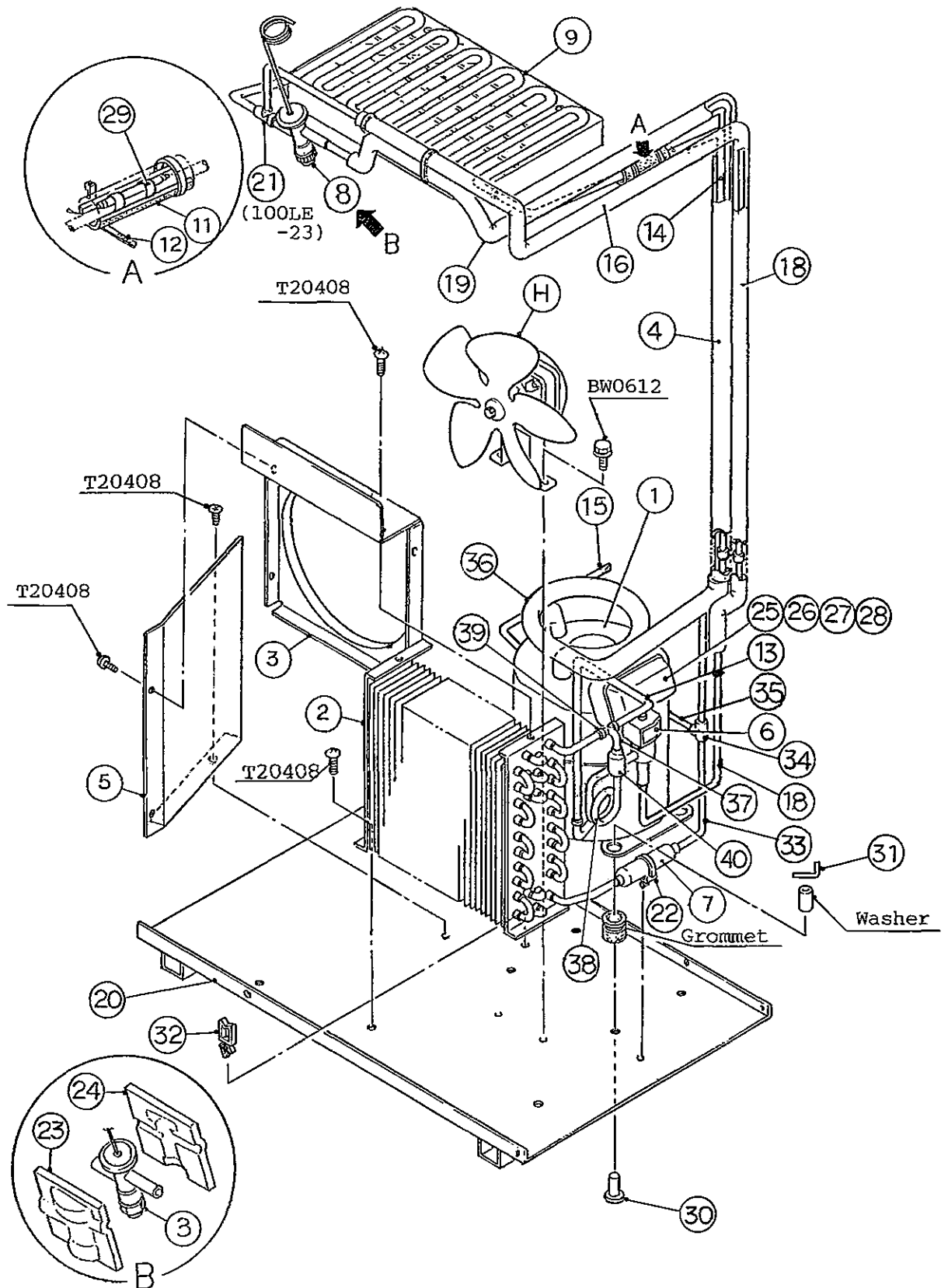

HE,GENERAL,EXPORT,OCEANIA,RINNAI,KOREA,AUSTRALIA,HSP

MODEL : IM-100LE							
IM-100LE-21,-23				TITLE : B. REFRIGERATION ASSY			
INDEX NO.	DESCRIPTION	MATERIAL OR MODEL NUMBER	PART NUMBER	REQ'D NUMBER			
				F-1	G-0 H-0	H-1 J-0 K-0 A-0 B-0 C-0 D-0	D-1 E-0
H	FAN MOTOR ASSY	(S-0950)	3H9446A01	1	1	1	1
1	COMPRESSOR	SC18G	452236-01	1	1	1	1
2	CONDENSER - AIR-COOLED	-	2H3237-01	1	1	1	1
3	SHROUD	G.S	3X4788-01	1	1	1	1
4	INSULATION TUBE	16 ID x 26 OD, L=800	1H1519-43	1	1	1	1
5	BARRIER (B)	G.S	3H9391-01	1	1	1	1
6	HOT GAS VALVE	ATS-7S10HD-1	418636-02	1	1	1	1
7	DRIER	DY-20QHD-1	452203-01	1	—		
		DML032.5S	462965-01		1	1	1
8	EXPANSION VALVE	FSE-5QHD-1	452202-01	1	1	1	1
9	EVAPORATOR	(100LE)	2H6438G02	1	1	1	1
	EVAPORATOR	(100LE-21)	2H0716G01	1	1	1	1
	EVAPORATOR (S-0796)	(100LE-23),	2H1836G01	1	1	1	1
10	-	-	-				
11	INSULATION TUBE	25 ID x 35 OD, L=130	4X8643-01	1	1	1	1
12	TIE	CV-150	7920-0003	4	4	4	4
13	COPPER TUBE (A)	COPPER	4X4048-01	1	1	1	1
14	HEAT EXCHANGER	-	4X5034G01	1	1	1	1
15	PROCESS TUBE	COPPER	4X4047-01	1	1	1	1
16	COPPER TUBE (A) - HOT GAS	COPPER	4X4049G01	1	1	1	1
17	-	-	-				
18	COPPER TUBE (B) - HOT GAS	COPPER	4X4050G01	1	1	1	1
20	BASE	PAINTED STEEL	3Y2586G01	1	1	1	1
21	TEE	(100LE-23)	420336-01	1	1	1	1
22	TIE	T50RSF	436156-02	1	1	1	1
23	COVER (A) - EXPANSION VALVE	PE FOAM	4H9239-01	1	1	1	1
24	COVER (B) - EXPANSION VALVE	PE FOAM	4H9239-02	1	1	1	1
25	STARTING RELAY	117U6019	452237-01	1	1	1	1
26	STARTING CAPACITOR	117U5019	456350-01	1	1	1	1
27	CORD RELIEF	103N1004	452239-01	1	1	1	1

HE,GENERAL,EXPORT,OCEANIA,RINNAI,KOREA,AUSTRALIA,HSP

MODEL : IM-100LE							
IM-100LE-21,-23				TITLE : B. REFRIGERATION ASSY			
INDEX NO.	DESCRIPTION	MATERIAL OR MODEL NUMBER	PART NUMBER	REQ'D NUMBER			
				E-1 R-0 S-0	S-1	S-2 T-0	T-1 U-0
H	FAN MOTOR ASSY	(S-0950)	3H9446A01	1	1	1	1
1	COMPRESSOR	SC18G	452236-01	1	1	1	1
2	CONDENSER - AIR-COOLED	-	2H3237-01	1	1	1	1
3	SHROUD	G.S	3X4788-01	1	1	1	1
4	INSULATION TUBE	16 ID x 26 OD, L=800	1H1519-43	1	1	1	1
5	BARRIER (B)	G.S	3H9391-01	1	1	1	1
6	HOT GAS VALVE	ATS-7S10HD-1	418636-02	1	1	1	1
7	DRIER	-	-				
		DML032.5S	462965-01	1	1	1	1
8	EXPANSION VALVE	FSE-5QHD-1	452202-01	1	1	1	1
9	EVAPORATOR	(100LE)	2H6438G02	1	1	1	1
	EVAPORATOR	(100LE-21)	2H0716G01	1	1	1	1
	EVAPORATOR (S-0796)	(100LE-23),	2H1836G01	1	1	1	1
10	-	-	-				
11	INSULATION TUBE	25 ID x 35 OD, L=130	4X8643-01	1	1	1	1
12	TIE	CV-150	7920-0003	4	4	4	4
13	COPPER TUBE (A)	COPPER	4X4048-01	1	1	1	1
14	HEAT EXCHANGER	-	4X5034G01	1	1	1	1
15	PROCESS TUBE	COPPER	4X4047-01	1	1	1	1
16	COPPER TUBE (A) - HOT GAS	COPPER	4X4049G01	1	1	1	1
17	-	-	-				
18	COPPER TUBE (B) - HOT GAS	COPPER	4X4050G01	1	1	1	1
20	BASE	PAINTED STEEL	3Y2586G01	1	1	1	1
21	TEE	(100LE-23)	420336-01	1	1	1	1
22	TIE	T50RSF	436156-02	1	1	1	1
23	COVER (A) - EXPANSION VALVE	PE FOAM	4H9239-01	1	1	1	1
24	COVER (B) - EXPANSION VALVE	PE FOAM	4H9239-02	1	1	1	1
25	STARTING RELAY	117U6019	452237-01	1	1	1	1
26	STARTING CAPACITOR	117U5019	456350-01	1	1	1	1
27	CORD RELIEF	103N1004	452239-01	1	1	1	1

HE,GENERAL,EXPORT,OCEANIA,RINNAI,KOREA,AUSTRALIA,HSP

MODEL : IM-100LE							
IM-100LE-21,-23				TITLE : B. REFRIGERATION ASSY			
INDEX NO.	DESCRIPTION	MATERIAL OR MODEL NUMBER	PART NUMBER	REQ'D NUMBER			
				F-1	G-0 H-0	H-1 J-0 K-0 A-0 B-0 C-0 D-0	D-1 E-0
28	COVER	103N2009	459924-01	1	1	1	1
29	CLIP	068N2530	452254-01	2	2	2	2
30	STEEL PIN		452255-01	4	4	4	4
31	CLIP		452256-01	4	4	4	4
32	WIRE SADDLE	LWS-2NS	428060-03	1	1	1	1
33	COPPER TUBE - B	COPPER	4H9160-01	1	—		
		COPPER	4X4243-01		1	1	1
34	TEE	COPPER	417394-01	1	1	1	1
35	PIPE	COPPER	4H9158-03	1	1	1	1
36	COPPER TUBE - LOW SIDE	COPPER	4X4044G01	1	1	1	1
37	PIPE(A)-2HIGH SIDE	COPPER	4H2708-01	1	1	1	1
38	COPPER TUBE - CIRCLE	COPPER	4X4182-01	1	1	1	1
39	TEE	COPPER	420041-03	1	1	1	1
40	STRAINER	COPPER	430365-01	1	1	1	1

HE,GENERAL,EXPORT,OCEANIA,RINNAI,KOREA,AUSTRALIA,HSP

MODEL : IM-100LE IM-100LE-21,-23								TITLE : B. REFRIGERATION ASSY			
INDEX NO.	DESCRIPTION	MATERIAL OR MODEL NUMBER	PART NUMBER	REQ'D NUMBER							
				E-1 R-0 S-0	S-1	S-2 T-0	T-1 U-0				
28	COVER	103N2009	459924-01	1	1	1	1				
29	CLIP	068N2530	452254-01	2	2	2	2				
30	STEEL PIN		452255-01	4	4	4	4				
31	CLIP		452256-01	4	4	4	4				
32	WIRE SADDLE	LWS-2NS	428060-03	1	1	1	1				
33	COPPER TUBE – B	-	-								
		COPPER	4X4243-01	1	1	1	1				
34	TEE	COPPER	417394-01	1	1	1	1				
35	PIPE	COPPER	4H9158-03	1	1	1	1				
36	COPPER TUBE – LOW SIDE	COPPER	4X4044G01	1	1	1	1				
37	PIPE(A)-2HIGH SIDE	COPPER	4H2708-01	1	1	1	1				
38	COPPER TUBE – CIRCLE	COPPER	4X4182-01	1	1	1	1				
39	TEE	COPPER	420041-03	1	1	1	1				
40	STRAINER	COPPER	430365-01	1	1	1	1				

IM-100LE
IM-100LE-23, -21

C. ICE MAKING MECHANISM ASSY

(E-1) and later
(C-0) (D-0) (D-1) (E-0)
(J-0) (K-0) (A-0) (B-0)
(F-1) (G-0) (H-0) (H-1)

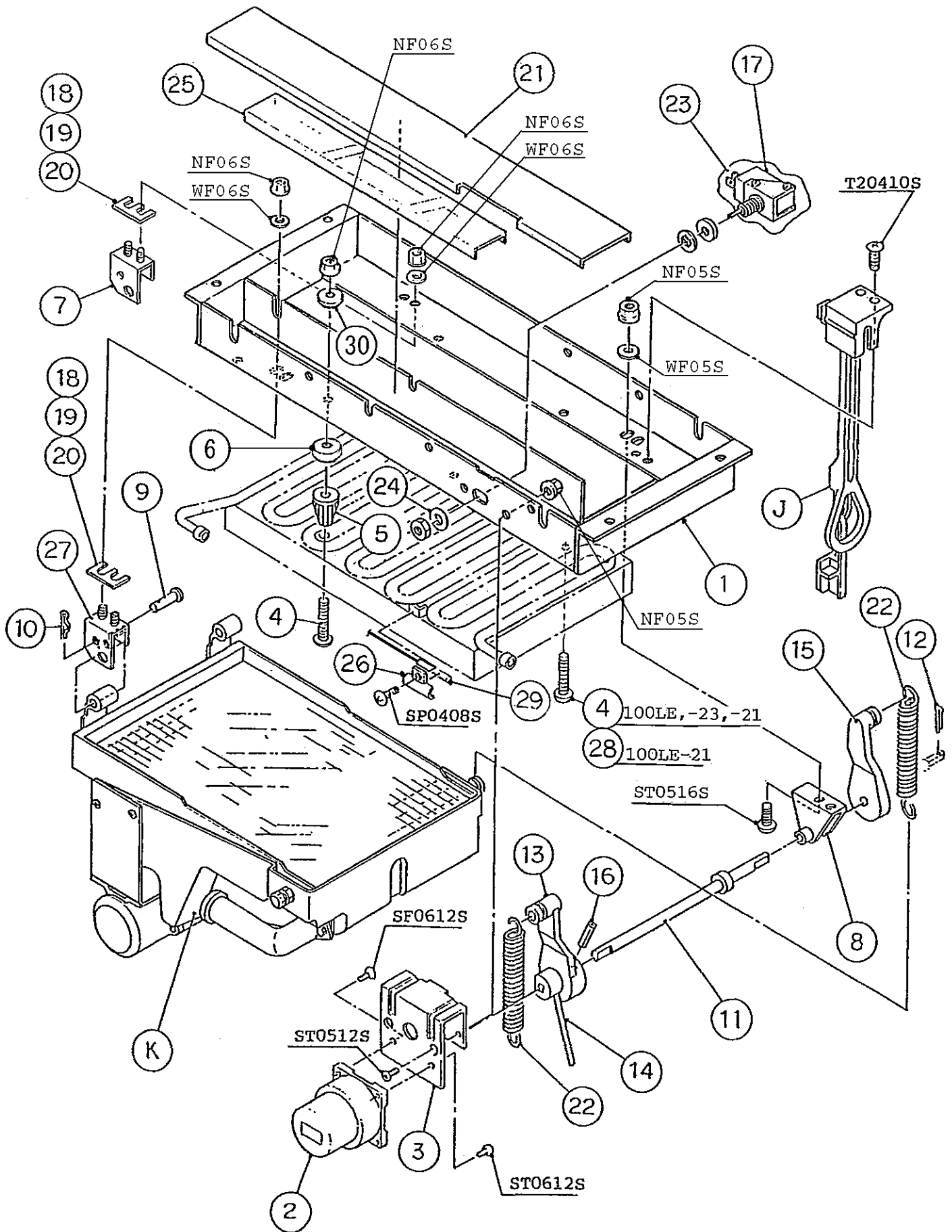

HE,GENERAL,EXPORT,OCEANIA,RINNAI,KOREA,AUSTRALIA,HSP

MODEL : IM-100LE							
IM-100LE-21,-23				TITLE : C. ICE MAKING MECHANISM ASSY			
INDEX NO.	DESCRIPTION	MATERIAL OR MODEL NUMBER	PART NUMBER	REQ'D NUMBER			
				F-1 G-0 H-0	H-1 J-0 K-0 A-0 B-0 C-0 D-0	D-1 E-0	E-1 R-0 S-0
J	BIN CONTROL SWITCH ASSY	(S-0819)	3H1538A02	1	1	1	1
K	WATER PAN ASSY	(100LE,-23)	2H0679A03	1	1	1	1
	WATER PAN ASSY	(100LE-21)	-	1	1	1	1
1	BRACKET - ICE MAKING MECHANISM	(100LE,-23)	3H9594-01	1	1	1	1
		(100LE-21)	3X0254-01	1	1	1	1
2	ACTUATOR MOTOR	SR65A41-13	452499-01	1	1	1	1
3	BRACKET - ACTUATOR MOTOR	PAINTED STEEL	4H2679-01	1	1	1	1
4	BOLT - EVAPORATOR MOUNTING	(100LE)	4H2678-01	4	4	4	4
	BOLT - EVAPORATOR MOUNTING	(100LE-21)	4H2886-01	2	2	2	2
	BOLT - EVAPORATOR MOUNTING	(100LE-23)	4H2886-01	4	4	4	4
5	COLLAR		3H3879-01	4	4	4	4
6	WASHER	(100LE-21)	4H1365-06	4	4	4	4
		(100LE-23)	4H1365-05	4	4	4	4
7	HANGER BRACKET	S.S	3H1440G02	1	1	1	1
8	BEARING - CAM SHAFT	POM	3X8307-01	1	1	1	1
9	SHAFT (B)	S.S	4H1184-02	2	2	2	2
10	SNAP PIN	S.S, NO. 6	715S-0600	2	2	2	2
11	CAM SHAFT	S.S	4H2702G01	1	1	1	1
12	COTTER PIN	S.S, 2x12	711S-0212	1	1	1	1
13	CAM (A)	(303881A02)	306543G02	1	1	1	1
14	CHANGE LEVER	S.S	406261-01	1	1	1	1
15	CAM (B)	AC	315775-01	1	1	1	1
16	ROLL PIN	S.S, 3x28	712S-0328	1	1	1	1
17	TOGGLE SWITCH	VAT4-71	431977-01	1	1	1	1
18	SHIM (A) - EVAPORATOR	S.S	4H2691-01	REQ'D	REQ'D	REQ'D	REQ'D
19	SHIM (B) - EVAPORATOR	S.S	4H2691-02	REQ'D	REQ'D	REQ'D	REQ'D
20	SHIM (C) - EVAPORATOR	S.S	4H2691-03	REQ'D	REQ'D	REQ'D	REQ'D
21	COVER - ICE MAKING MECHANISM BRACKET	PVC	4H2681-01	1	1	1	1
22	SPRING	S.S	4H0287-01	2	2	2	2
23	SWITCH COVER	PE	408163-01	1	1	1	1
24	WASHER - TOGGLE SWITCH	S.S	406196-01	1	1	1	1
25	GUIDE - CONNECTOR	PVC	4H5619-01	1	1	1	1

HE,GENERAL,EXPORT,OCEANIA,RINNAI,KOREA,AUSTRALIA,HSP

MODEL : IM-100LE							
IM-100LE-21,-23			TITLE : C. ICE MAKING MECHANISM ASSY				
INDEX NO.	DESCRIPTION	MATERIAL OR MODEL NUMBER	PART NUMBER	REQ'D NUMBER			
				S-1	S-2 T-0	T-1 U-0	
J	BIN CONTROL SWITCH ASSY	(S-0819)	3H1538A02	1	1	1	
K	WATER PAN ASSY	(100LE,-23)	2H0679A03	1	1	1	
	WATER PAN ASSY	(100LE-21)	-	1	1	1	
1	BRACKET - ICE MAKING MECHANISM	(100LE,-23)	3H9594-01	1	1	1	
		(100LE-21)	3X0254-01	1	1	1	
2	ACTUATOR MOTOR	SR65A41-13	452499-01	1	1	1	
3	BRACKET - ACTUATOR MOTOR	PAINTED STEEL	4H2679-01	1	1	1	
4	BOLT - EVAPORATOR MOUNTING	(100LE)	4H2678-01	4	4	4	
	BOLT - EVAPORATOR MOUNTING	(100LE-21)	4H2886-01	2	2	2	
	BOLT - EVAPORATOR MOUNTING	(100LE-23)	4H2886-01	4	4	4	
5	COLLAR		3H3879-01	4	4	4	
6	WASHER	(100LE-21)	4H1365-06	4	4	4	
		(100LE-23)	4H1365-05	4	4	4	
7	HANGER BRACKET	S.S	3H1440G02	1	1	1	
8	BEARING - CAM SHAFT	POM	3X8307-01	1	1	1	
9	SHAFT (B)	S.S	4H1184-02	2	2	2	
10	SNAP PIN	S.S, NO. 6	715S-0600	2	2	2	
11	CAM SHAFT	S.S	4H2702G01	1	1	1	
12	COTTER PIN	S.S, 2x12	711S-0212	1	1	1	
13	CAM (A)	(303881A02)	306543G02	1	1	1	
14	CHANGE LEVER	S.S	406261-01	1	1	1	
15	CAM (B)	AC	315775-01	1	1	1	
16	ROLL PIN	S.S, 3x28	712S-0328	1	1	1	
17	TOGGLE SWITCH	VAT4-71	431977-01	1	1	1	
18	SHIM (A) - EVAPORATOR	S.S	4H2691-01	REQ'D	REQ'D	REQ'D	
19	SHIM (B) - EVAPORATOR	S.S	4H2691-02	REQ'D	REQ'D	REQ'D	
20	SHIM (C) - EVAPORATOR	S.S	4H2691-03	REQ'D	REQ'D	REQ'D	
21	COVER - ICE MAKING MECHANISM BRACKET	PVC	4H2681-01	1	1	1	
22	SPRING	S.S	4H0287-01	2	2	2	
23	SWITCH COVER	PE	408163-01	1	1	1	
24	WASHER - TOGGLE SWITCH	S.S	406196-01	1	1	1	
25	GUIDE - CONNECTOR	PVC	4H5619-01	1	1	1	

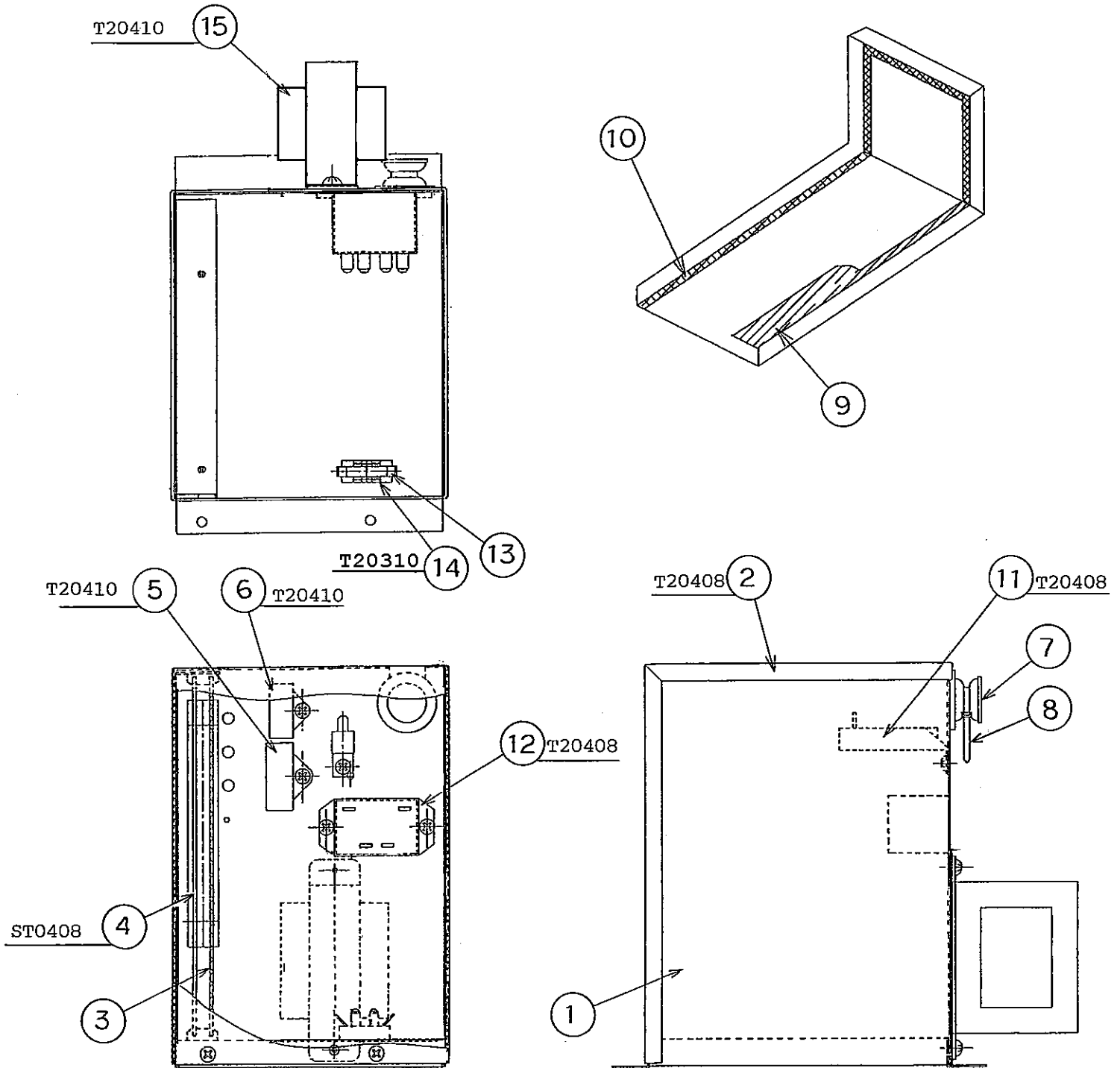

IM-100LE
IM-100LE-23, -21

D. CONTROL BOX ASSY

(E-0)
(B-0) (C-0) (D-0) (D-1)
(H-1) (J-0) (K-0) (A-0)

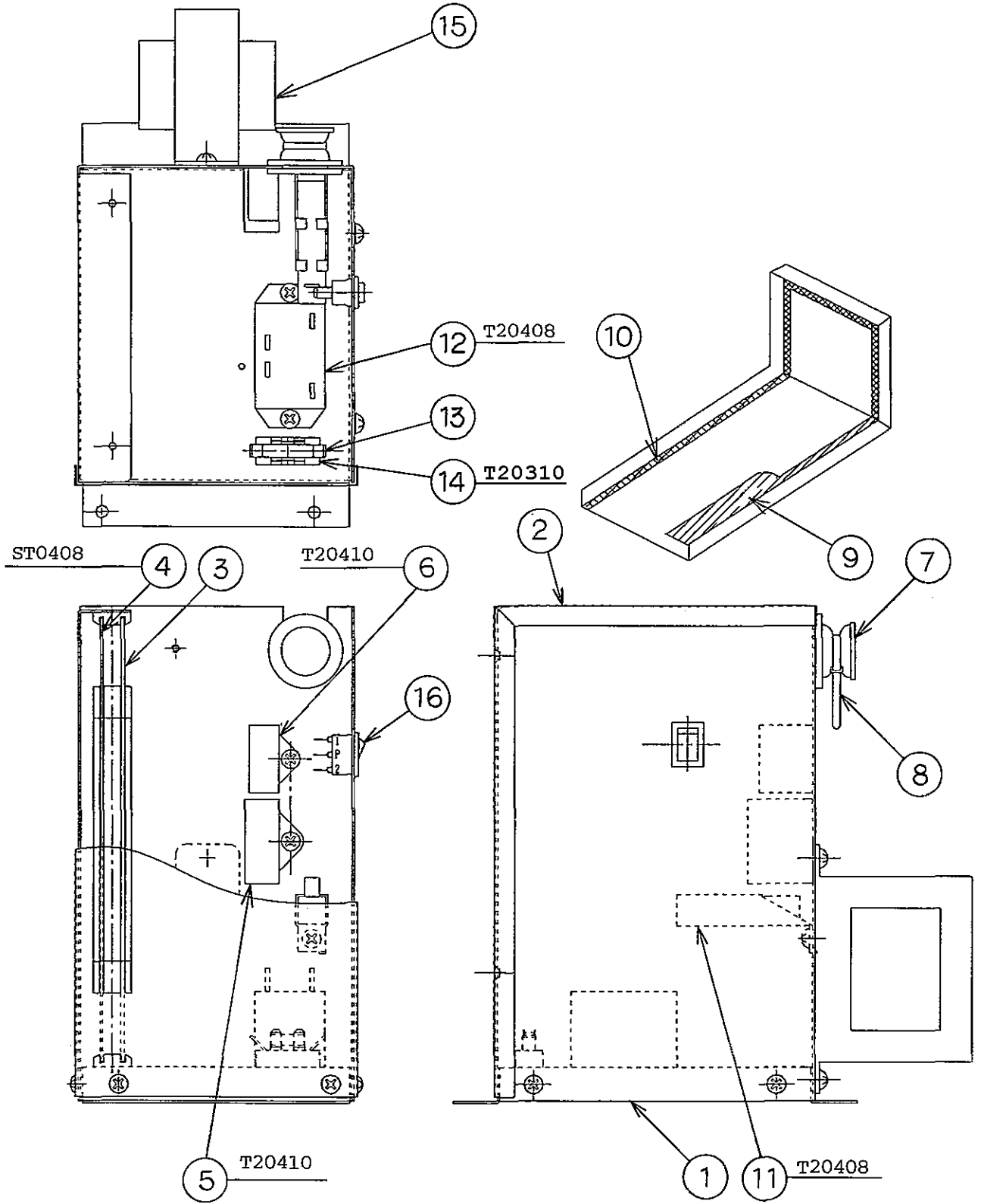

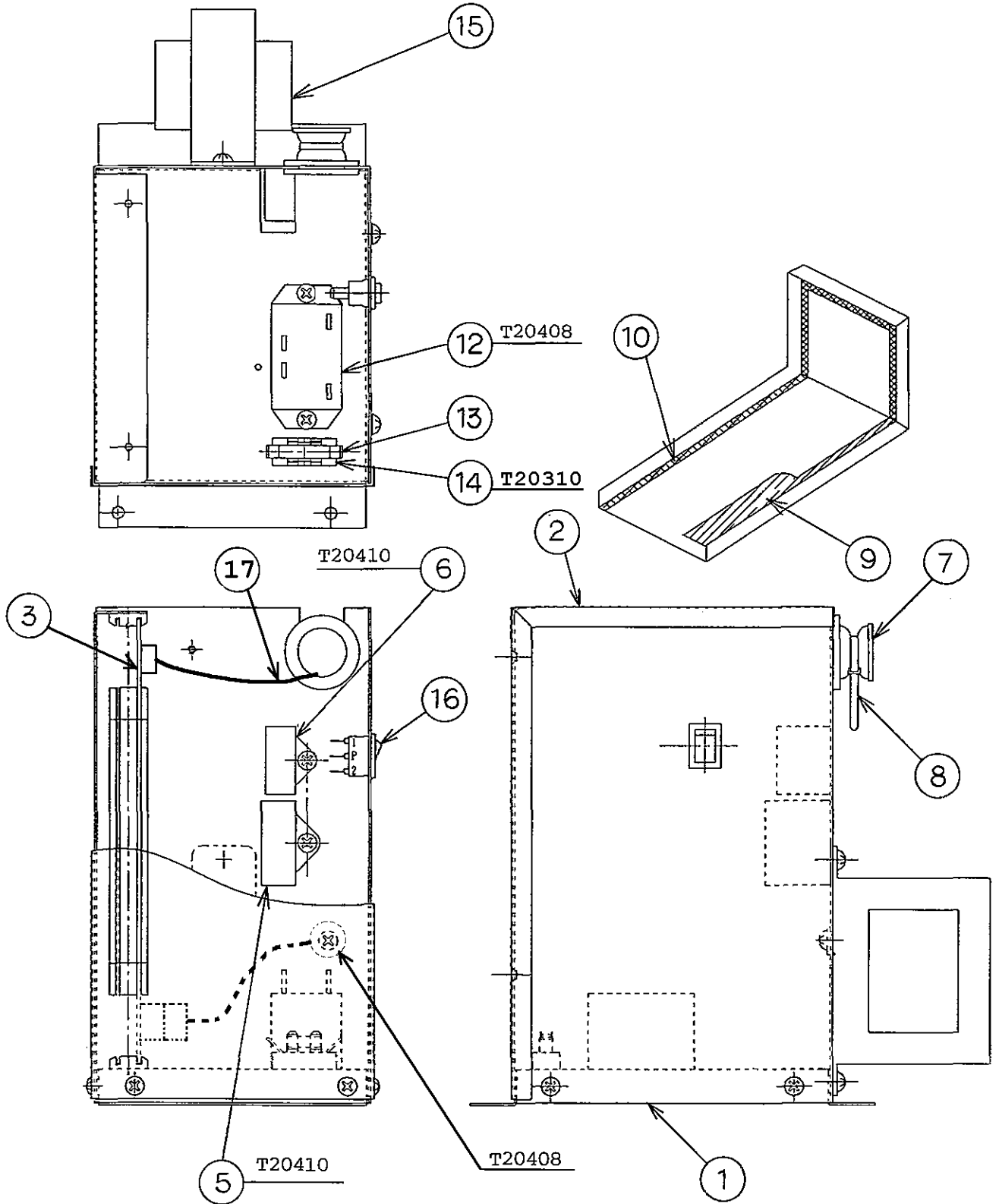

HE,GENERAL,EXPORT,OCEANIA,RINNAI,KOREA,AUSTRALIA,HSP

MODEL : IM-100LE							
IM-100LE-21,-23			TITLE : D. CONTROL BOX ASSY				
INDEX NO.	DESCRIPTION	MATERIAL OR MODEL NUMBER	PART NUMBER	REQ'D NUMBER			
				F-1 G-0 H-0	H-1 J-0 K-0 A-0 B-0 C-0 D-0	D-1 E-0	E-1 R-0 S-0
1	CONTROL BOX	G.S	3H9453G01	1	—		
		G.S	3H9453G02		1	—	
		G.S	3H9453G04			1	1
2	COVER - CONTROL BOX	G.S	3H9456-01	1	1	1	1
3	CONTROLLER BOARD	H2AA136C02	436572-02	1	1	1	—
		H2AE024C18	462975-18				1
4	SHIELD PLATE	G.S	4H2594-01	1	1	1	×
5	CAPACITOR - PUMP MOTOR	4.0UF	416920-02	1	1	1	1
6	CAPACITOR - ACTUATOR MOTOR	0.8UF	416921-08	1	1	1	1
7	GROMMET	NBR	4H2568-01	1	1	1	1
8	NYLON TIE	PRT1.5S	427466-01	1	1	1	1
9	CUSHION	20 x 210 x 2.5t, PE	4H2718-01	1	1	1	1
10	SEAL TAPE	w12 x t3.0	2H3234-18	1	1	1	—
		w12 x t3.0	2H6792-12				1
11	SURGE ABSORBER	-	436573-02	1	1	1	×
12	POWER RELAY	G7L-1A-TUB	449000-01	1	1	1	1
13	FUSE	5A	451924-01	1	1	1	1
14	FUSE HOLDER	445710	451925-01	1	1	—	
		CFH15	4Y2547-01			1	1
15	TRANSFORMER	230V / 100V	450104-01	1	1	1	1
16	ROCKER SWITCH	H8600VB	460681-01		1	1	1
17	THERMISTOR-AMBIENT TEMP	182-103-86742	462977-02				1

HE,GENERAL,EXPORT,OCEANIA,RINNAI,KOREA,AUSTRALIA,HSP

MODEL : IM-100LE							
IM-100LE-21,-23				TITLE : D. CONTROL BOX ASSY			
INDEX NO.	DESCRIPTION	MATERIAL OR MODEL NUMBER	PART NUMBER	REQ'D NUMBER			
				S-1	S-2 T-0	T-1 U-0	
1	CONTROL BOX	-	-				
		-	-				
		G.S	3H9453G04	1	1	1	
2	COVER - CONTROL BOX	G.S	3H9456-01	1	1	1	
3	CONTROLLER BOARD	-	-				
		H2AE024C18	462975-18	1	1	1	
4	-	-	-				
5	CAPACITOR - PUMP MOTOR	4.0UF	416920-02	1	1	1	
6	CAPACITOR - ACTUATOR MOTOR	0.8UF	416921-08	1	1	1	
7	GROMMET	NBR	4H2568-01	1	1	1	
8	NYLON TIE	PRT1.5S	427466-01	1	1	1	
9	CUSHION	20 x 210 x 2.5t, PE	4H2718-01	1	1	1	
10	SEAL TAPE	-	-				
		w12 x t3.0	2H6792-12	1	1	1	
11	-	-	-				
12	POWER RELAY	G7L-1A-TUB	449000-01	1	1	1	
13	FUSE	5A	451924-01	1	1	1	
14	FUSE HOLDER	-	-				
		CFH15	4Y2547-01	1	1	1	
15	TRANSFORMER	230V / 100V	450104-01	1	1	1	
16	ROCKER SWITCH	H8600VB	460681-01	1	1	1	
17	THERMISTOR-AMBIENT TEMP	182-103-86742	462977-02	1	1	1	

IM-100LE
IM-100LE-23 , -21

E. DOOR ASSY

(E-1) (R-0) (S-0) (S-1)
(C-0) (D-0) (D-1) (E-0)
(J-0) (K-0) (A-0) (B-0)
(F-1) (G-0) (H-0) (H-1)

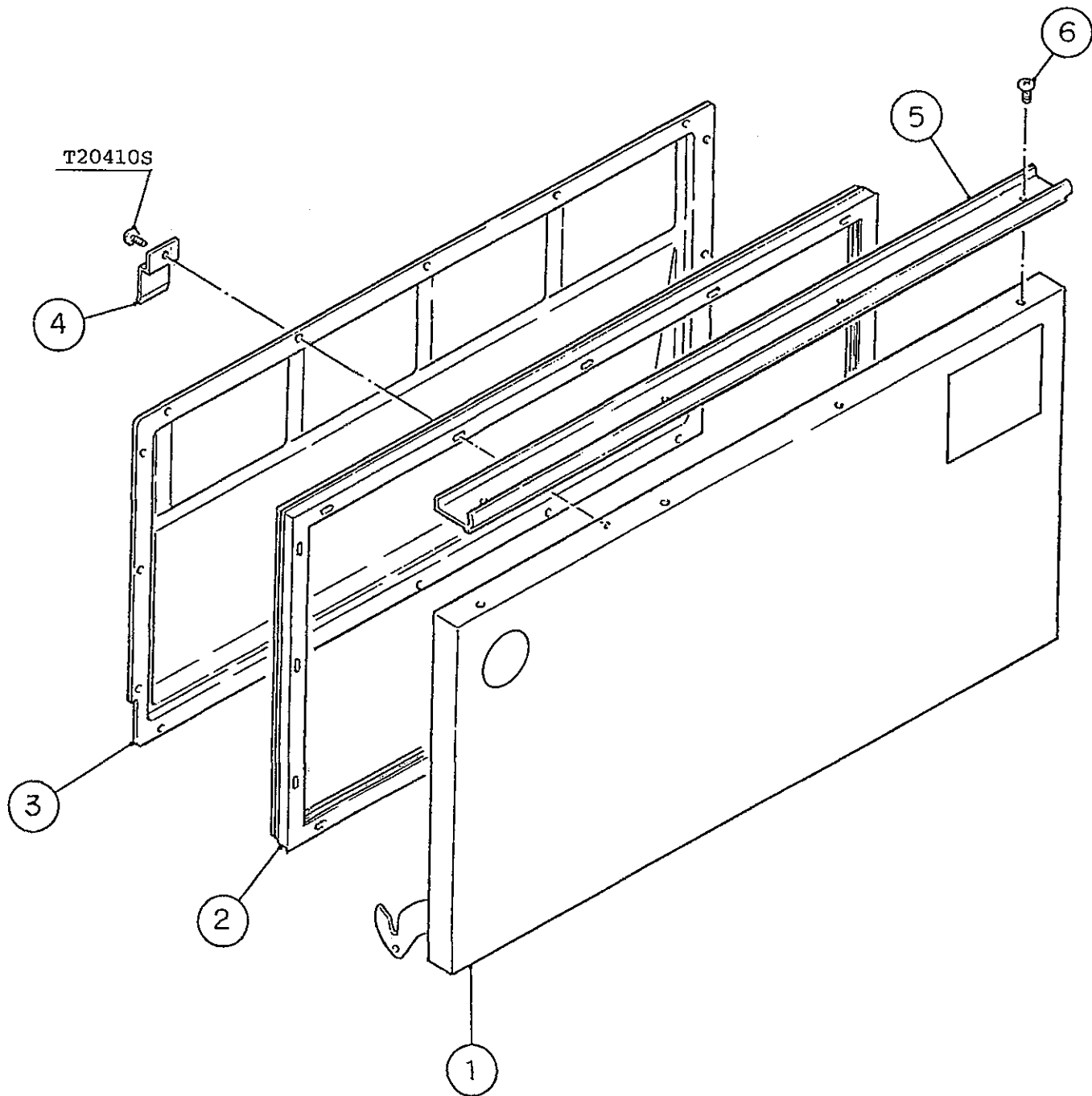

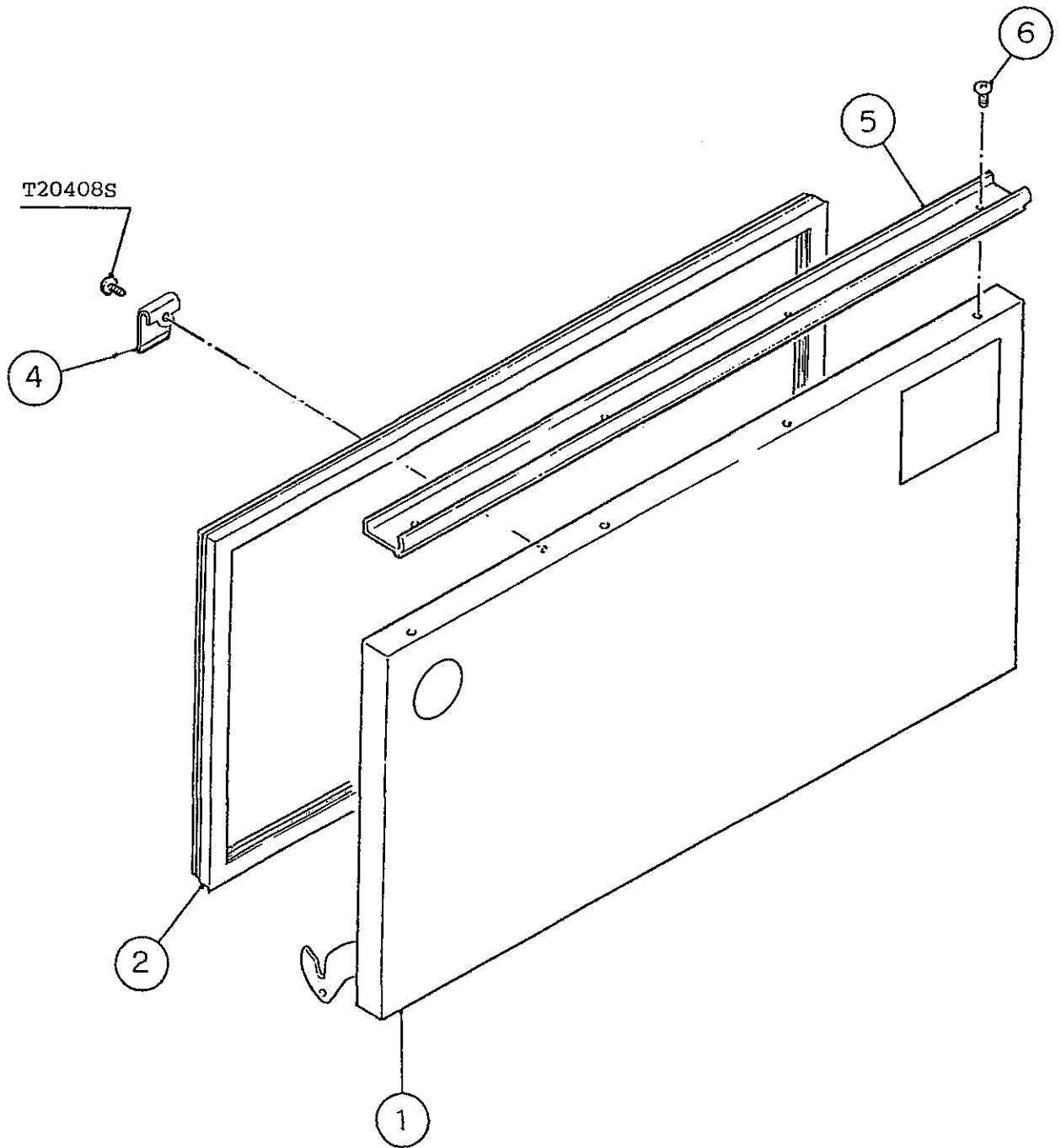

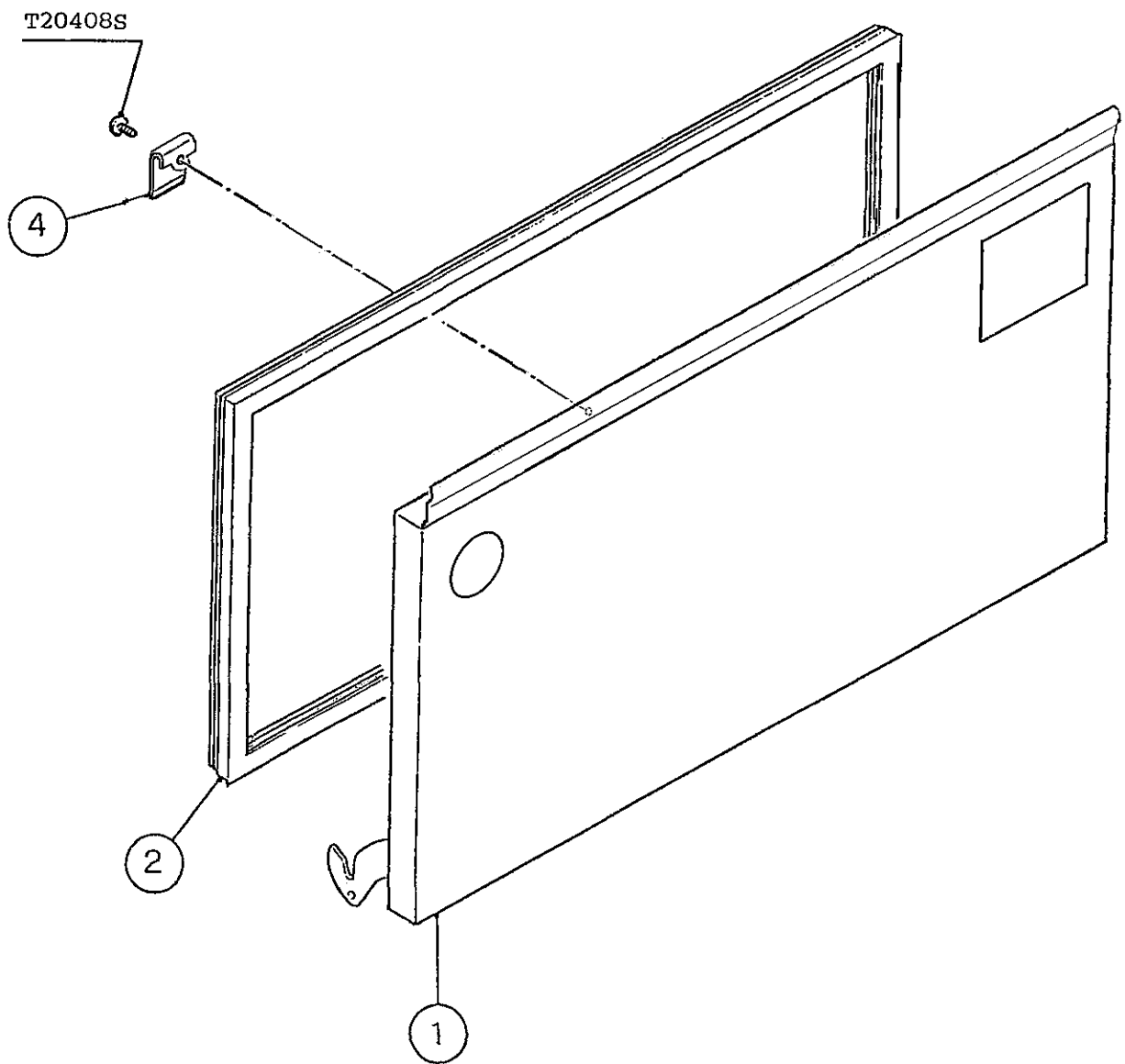

HE,GENERAL,EXPORT,OCEANIA,RINNAI,KOREA,AUSTRALIA,HSP

MODEL : IM-100LE IM-100LE-21,-23								TITLE : E. DOOR ASSY			
INDEX NO.	DESCRIPTION	MATERIAL OR MODEL NUMBER	PART NUMBER	REQ'D NUMBER							
				F-1 G-0 H-0	H-1 K-0 A-0 B-0 C-0 D-0	D-1 E-0	E-1 R-0 S-0				
1	DOOR	S.S	3H9272G01	1	1	1	1				
		S.S	3Y2908G01								
		S.S	3Y3816G01								
2	GASKET	PVC RUBBER	3H1431-03	1	1	1	1				
		PVC RUBBER	3X3545-01								
3	REVERSE COVER	ABS	3X4833-01	1	1	1	1				
4	CATCH - SLOPE	S.S	4H0439-01	1	1	1	1				
		S.S	4X7644-01								
5	HANDLE	ABS	328924-04	1	1	1	1				
6	TAPPING SCREW - BLACK	STEEL, 4x8	433954-01	4	4	4	4				

HE,GENERAL,EXPORT,OCEANIA,RINNAI,KOREA,AUSTRALIA,HSP

MODEL : IM-100LE							
IM-100LE-21,-23			TITLE : E. DOOR ASSY				
INDEX NO.	DESCRIPTION	MATERIAL OR MODEL NUMBER	PART NUMBER	REQ'D NUMBER			
				S-1	S-2 T-0	T-1 U-0	
1	DOOR	S.S	3H9272G01	1	—		
		S.S	3Y2908G01		1	—	
		S.S	3Y3816G01			1	
2	GASKET	PVC RUBBER	3H1431-03	1	—		
		PVC RUBBER	3X3545-04		1	1	
3	REVERSE COVER	ABS	3X4833-01	1	×		
4	CATCH - SLOPE	S.S	4H0439-01	1	—		
		S.S	4X7644-01		1	1	
5	HANDLE	ABS	328924-04	1	1	×	
6	TAPPING SCREW - BLACK	STEEL, 4x8	433954-01	4	4	×	

IM-100LE
IM-100LE-23,-21

F. WATER CIRCUIT ASSY

(E-1) and later
(C-0) (D-0) (D-1) (E-0)
(J-0) (K-0) (A-0) (B-0)
(F-1) (G-0) (H-0) (H-1)

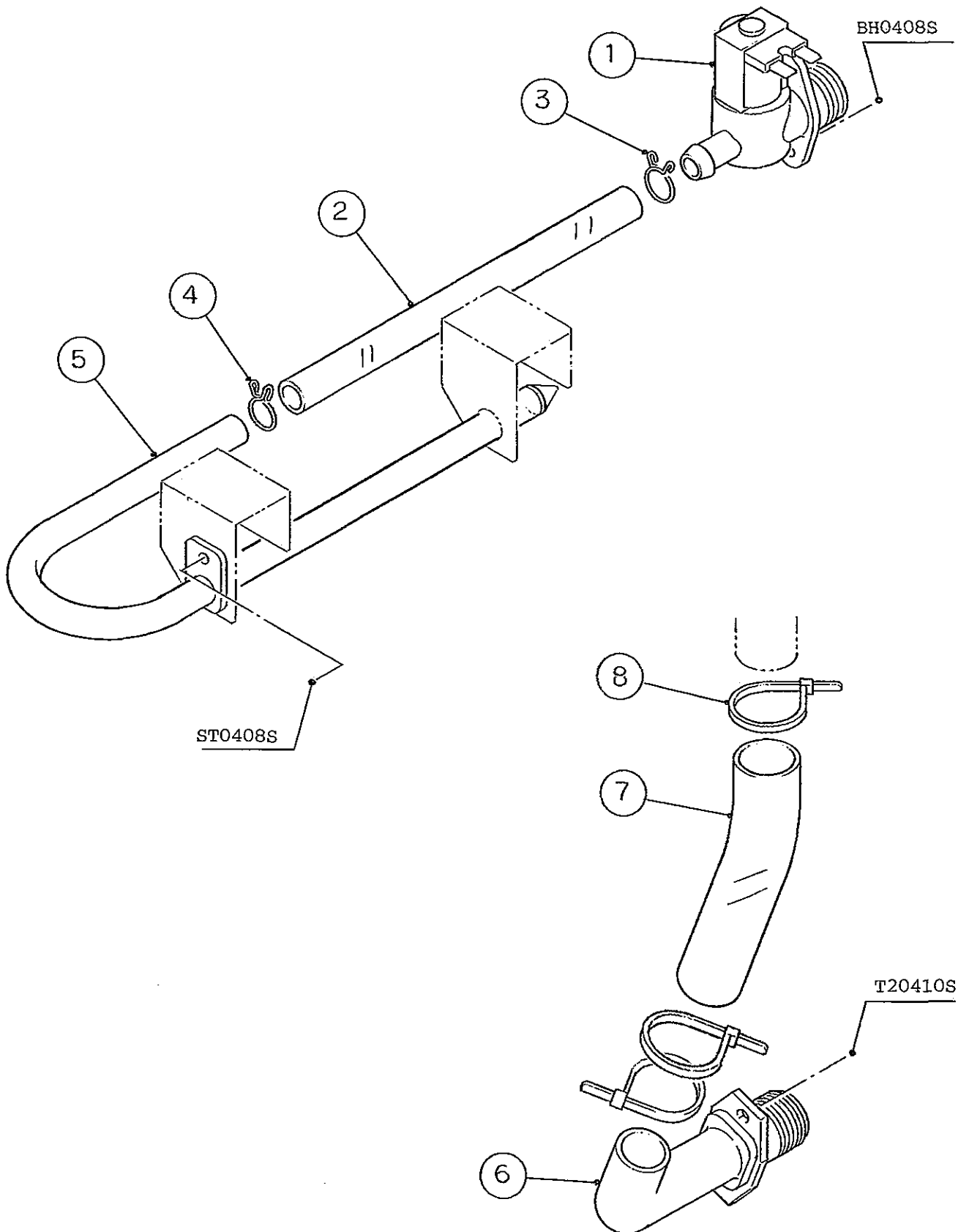

HE,GENERAL,EXPORT,OCEANIA,RINNAI,KOREA,AUSTRALIA,HSP

MODEL : IM-100LE							
IM-100LE-21,-23				TITLE : F. WATER CIRCUIT ASSY			
INDEX NO.	DESCRIPTION	MATERIAL OR MODEL NUMBER	PART NUMBER	REQ'D NUMBER			
				F-1 G-0 H-0	H-1 J-0 K-0 A-0 B-0 C-0 D-0	D-1 E-0	E-1 R-0 S-0
1	WATER VALVE	V18, 3.8 lit./min.	452138-01	1	1	1	1
2	SILICONE HOSE	7730-1215, L=200	3H9588-03	1	1	1	1
3	CLAMP	SK-15	435934-03	1	1	1	1
4	CLAMP	SK-14	433909-01	1	1	1	1
5	PIPE - WATER SUPPLY	ABS	3H9532G01	1	1	1	1
6	DRAIN PIPE	PVC	3H0394-01	1	1	1	1
7	HOSE	7711-2226, L=115	3H9588-10	1	1	1	1
8	TIE	CV-150	7920-0003	3	3	3	3

IM-100LE
IM-100LE-23 , -21

G. LABEL LOCATION

(E-1) and later
(C-0) (D-0) (D-1) (E-0)
(J-0) (K-0) (A-0) (B-0)
(F-1) (G-0) (H-0) (H-1)

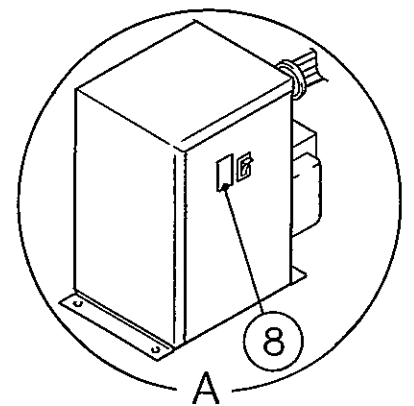
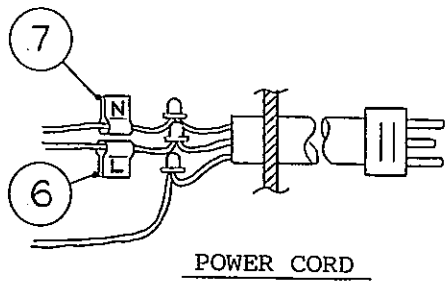
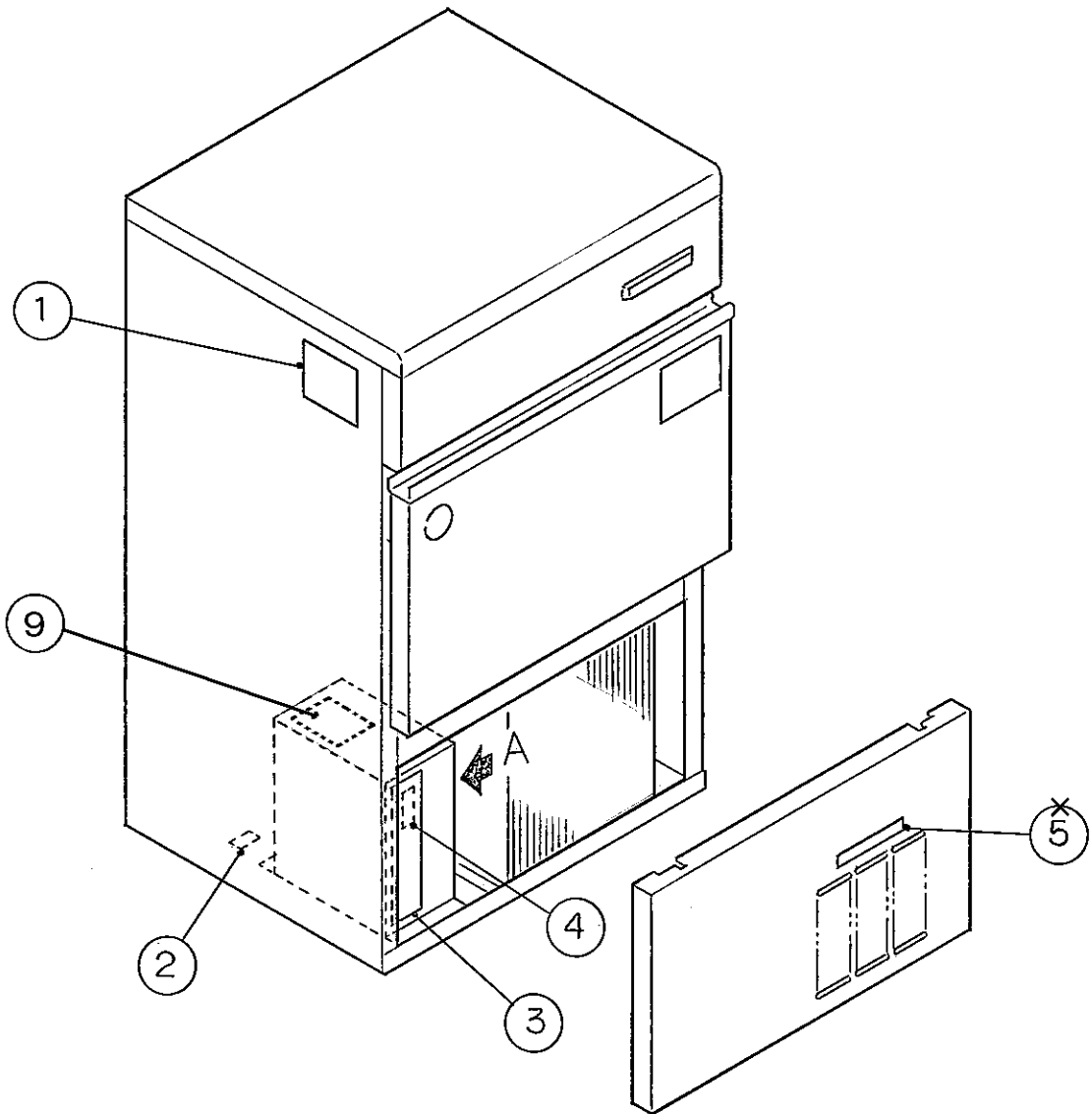

(S-0950)

IM-100LE
IM-100LE-23,-21

H. FAN MOTOR ASSY

(E-1) and later
(C-0) (D-0) (D-1) (E-0)
(J-0) (K-0) (A-0) (B-0)
(F-1) (G-0) (H-0) (H-1)

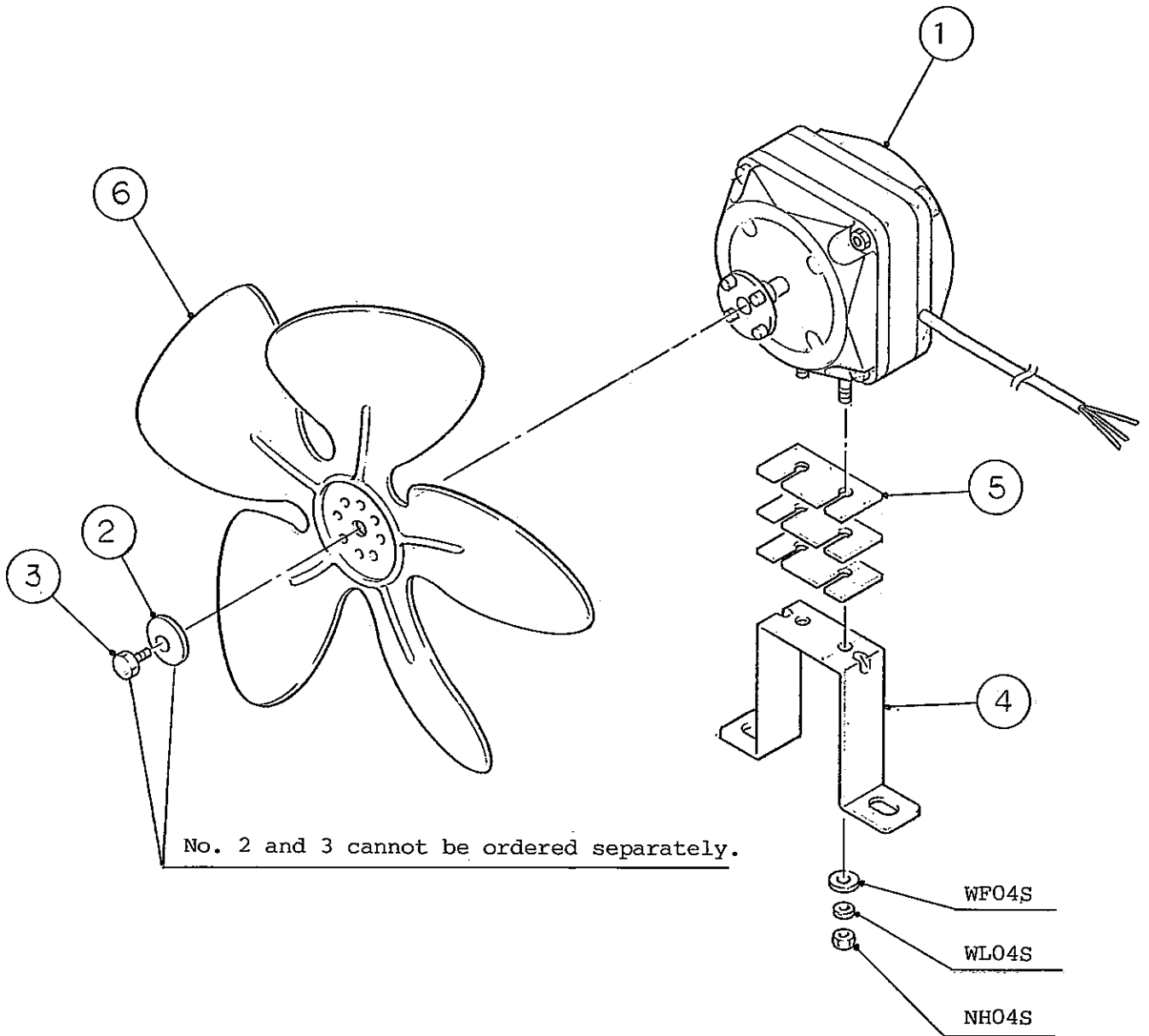

IM-100LE
IM-100LE-23 , -21

J. BIN CONTROL SWITCH ASSY

(E-1) and later
(C-0) (D-0) (D-1) (E-0)
(J-0) (K-0) (A-0) (B-0)
(F-1) (G-0) (H-0) (H-1)

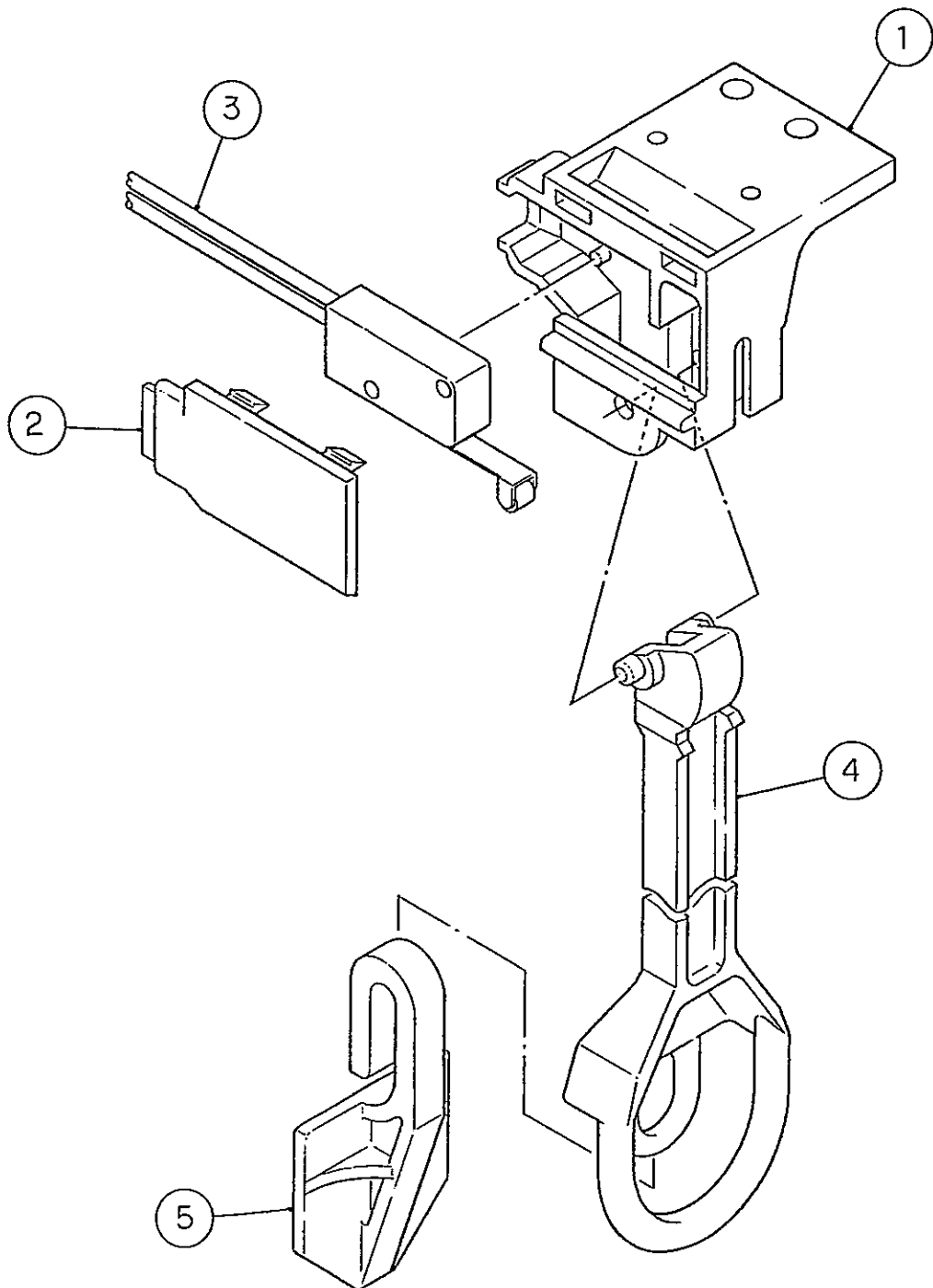

IM-100LE
IM-100LE-23,-21

K. WATER PAN ASSY

(E-1) and later
(C-0) (D-0) (D-1) (E-0)
(J-0) (K-0) (A-0) (B-0)
(F-1) (G-0) (H-0) (H-1)

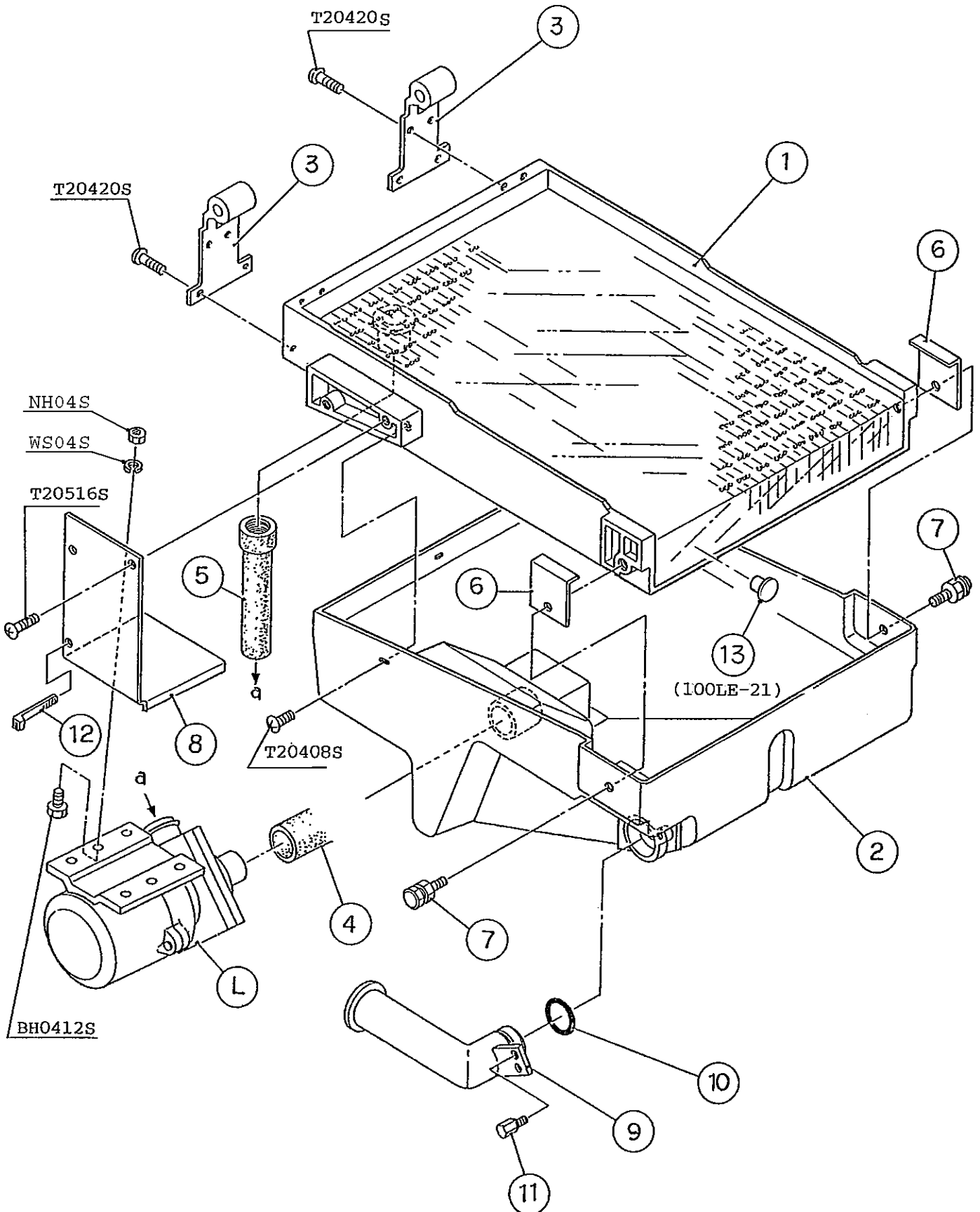

IM-100LE
IM-100LE-23 , -21

L. WATER PUMP ASSY

(E-1) and later
(C-0) (D-0) (D-1) (E-0)
(J-0) (K-0) (A-0) (B-0)
(F-1) (G-0) (H-0) (H-1)

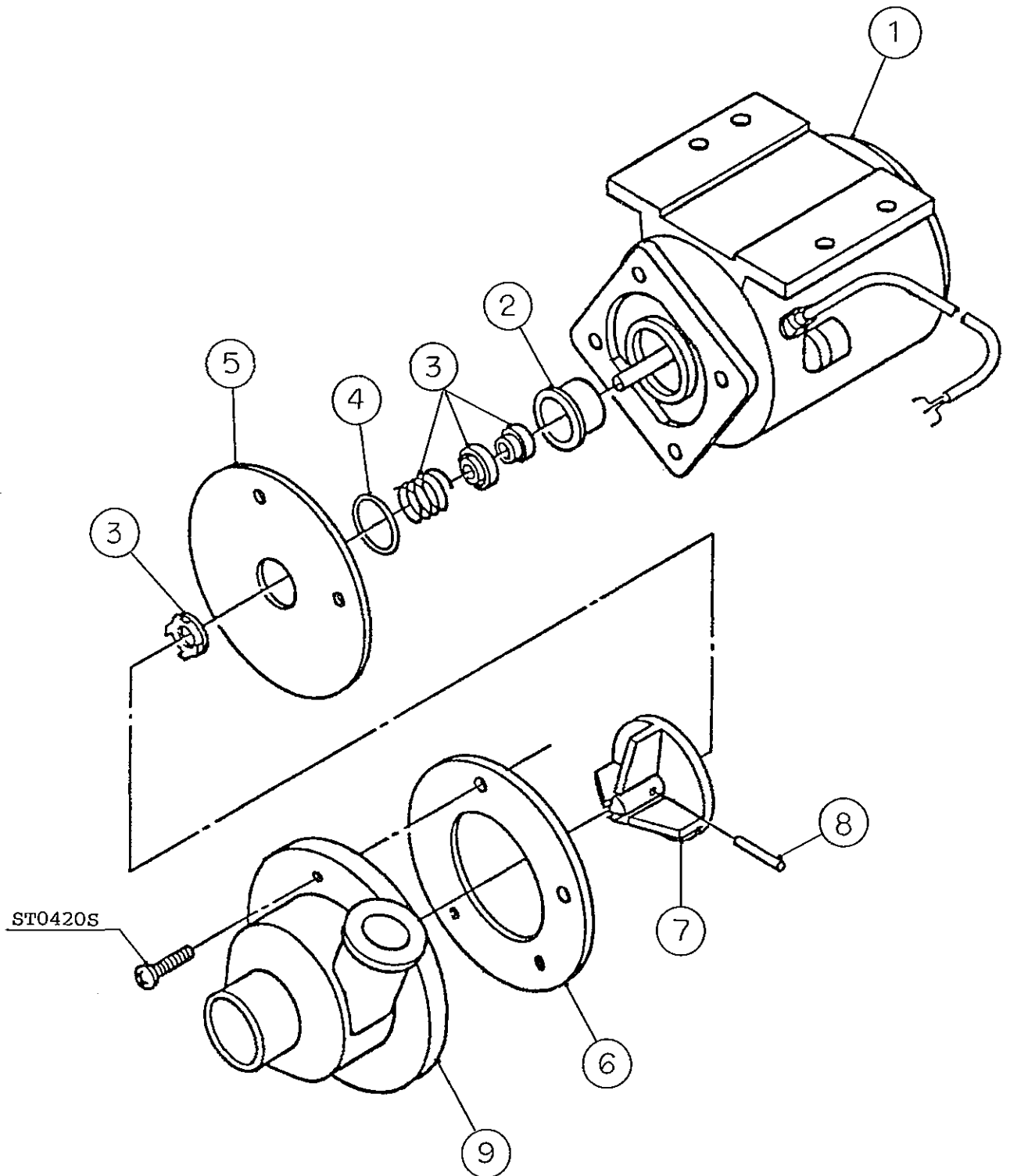

IM-100LE
IM-100LE-23,-21

M. ACCESSORIES

(E-1) and later
(C-0) (D-0) (D-1) (E-0)
(J-0) (K-0) (A-0) (B-0)
(F-1) (G-0) (H-0) (H-1)

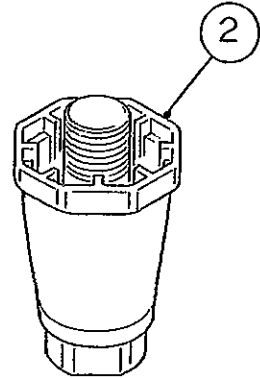
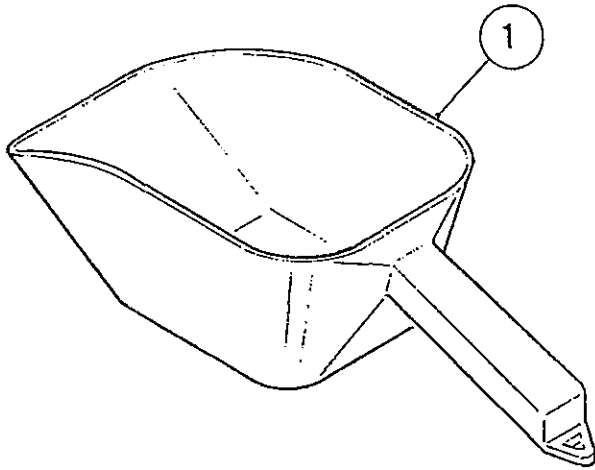

(HE, RINNAI, AUSTRALIA Only)

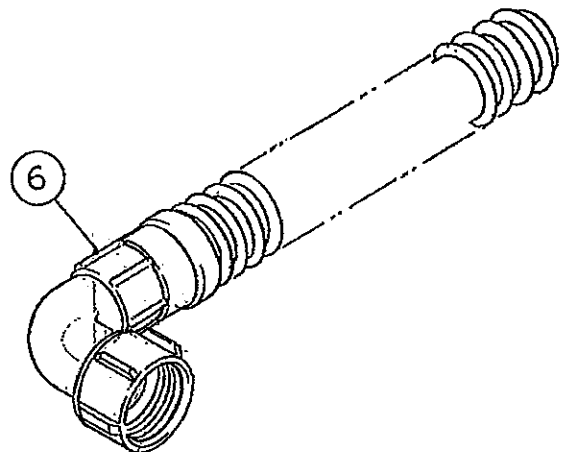
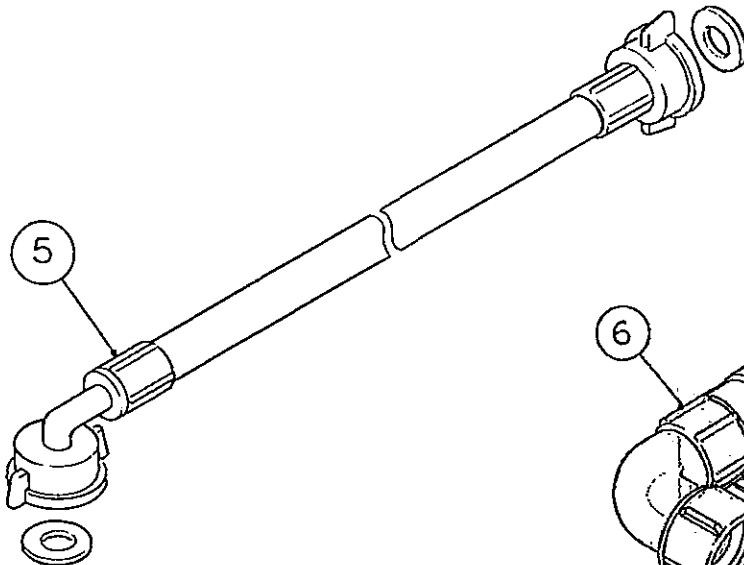
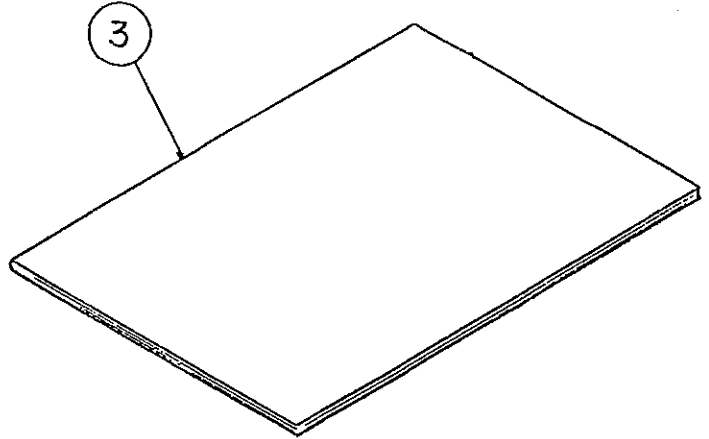
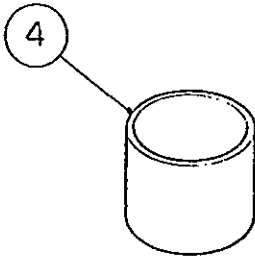

HE,GENERAL,EXPORT,OCEANIA,RINNAI,KOREA,AUSTRALIA,HSP

MODEL : IM-100LE IM-100LE-21,-23 TITLE : M. ACCESSORIES							
INDEX NO.	DESCRIPTION	MATERIAL OR MODEL NUMBER	PART NUMBER	REQ'D NUMBER			
				S-1	S-2 T-0	T-1 U-0	
1	SCOOP	PE	208185-01	1	1	1	
2	LEG	(HE) (RINNAI) (AUSTRALIA)	446729-01	4	4	4	
3	INSTRUCTION MANUAL	PAPER	-				
			-				
			91E1AX20F	1	1	1	
4	CAP	PE	417323-01	1	1	1	
5	INLET HOSE	HOSH01	450722-01	1	1	1	
6	OUTLET HOSE	62506	452365-01	1	1	1	