

ATTENZIONE: PER TENSIONI SPECIALI, SPECIFICARE SEMPRE IL MODELLO DI FORNO ED IL NUMERO DI MATRICOLA
ATTENTION: FOR SPECIAL VOLTAGES, PLEASE ALWAYS SPECIFY THE OVEN MODEL AND THE SERIAL NUMBER

ATTENTION: POUR TENSIONS SPÉCIALES, MERCI DE SPÉCIFIER TOUJOURS LE MODÈLE DU FOUR ET LE NUMÉRO DE SÉRIE
ACHTUNG: BEI SONDRSPANNUNGEN, BITTE IMMER OFEN-MODELL UND SERIENNUMMER GEBEN.

ed. 0713

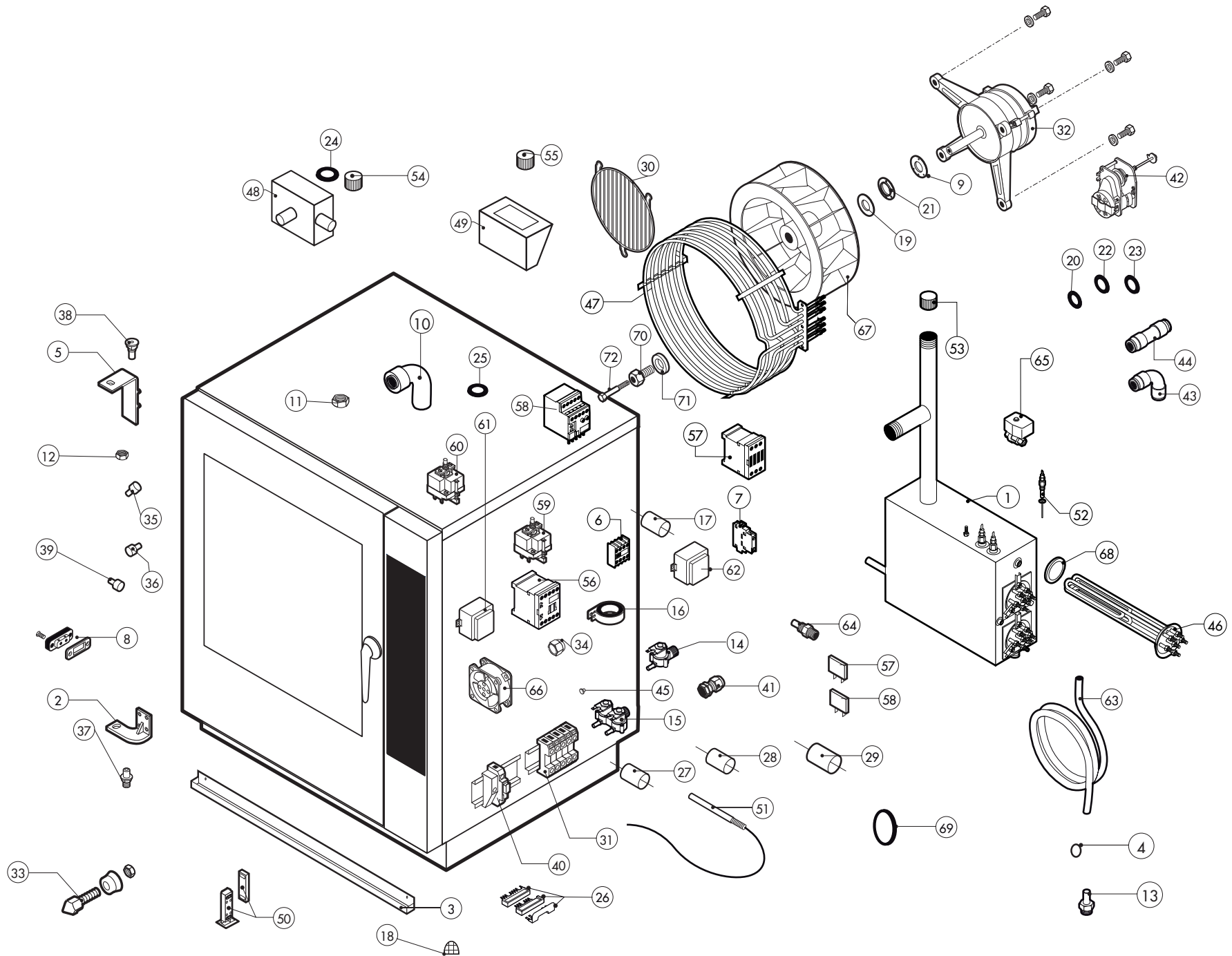

POS.	COD.	Pz.	DESCRIZIONE	DESCRIPTION	DESCRIPTION	BESCHREIBUNG	DESCRIPCIÓN
1	R11100630	1	BOILER C/CAL-OUT RESIST. COIBENT. KME101 SCAR. 3/4"	STEAM GENERATOR ASSEMBLY	CHAUDIERE COMPLETE	DAMPFERZEUGER KOMPLETT	BOILER COMPLETO
1	R11100331	1	BOILER C/CAL-OUT RESIST. COIBENT. KME101 SCAR. 1" DAL 28/01/2013	STEAM GENERATOR ASSEMBLY FROM 28/01/2013	CHAUDIERE COMPLETE DU 28/01/2013	DAMPFERZEUGER KOMPLETT VOM 28/01/2013	BOILER COMPLETO DEL 28/01/2013
2	R11207240	1	ASS.CERNIERA INF. M-V/061-101-102 2005	LOWER DOOR HINGE	CHARNIERE INFERIEURE PORTE	UNTERES SCHARNIER	BISAGRA INFERIOR
3	R69180150	1	BACINELLA SCARICO H-061	DRIP TRAY	PLATEAU D'ÉGOUTTEMENT	WASSERTROPFTASSE	BANDEJA DEL GOTEO
4	R62070023	2	BICONO PILOTA TUBO D.6 905.	BICONE D.6	BICONE D.6	KEGEL D.6	BICONO D.6
5	R11426830	1	CERNIERA SUPER.PORTA SR.2013	UPPER DOOR HINGE	CHARNIERE SUPERIEURE PORTE	OBERES SCHARNIER	BISAGRA SUPERIOR
6	R65140420	1	CONT.AUS. 1L+1R 3RH1911-1FA11 SIEMENS	AUX.CONTACT 1L+1R	CONTACT AUXILIAIRE 1L+1R	ZUSÄTZLICHER KONTAKT 1L+1R	CONTACTO AUXILIAR 1L+1R
7	R65140430	2	CONT.AUS. 1L+1R 3RH1921-1EA11 SIEMENS	AUX.CONTACT 1L+1R	CONTACT AUXILIAIRE 1L+1R	ZUSÄTZLICHER KONTAKT 1L+1R	CONTACTO AUXILIAR 1L+1R
8	R65260750	1	CONTATTO PER LUCI SR.2000	LAMPS CONTACT BLOCK	CONTACT ECLAIRAGE	LICHTKONTSCHALTER	CONTACTO PARA LUZ
9	R58003850	1	CONTROFLANGIA GUARN. GRANDE	MOTOR GASKET BRASS COUNTER FLANGE	CONTRE- BRIDE JOINT MOTEUR	GEGENFLANSCH F. MOTORDICHTUNG	CONTRABRIDA JUNTA MOTOR
10	R62280038	1	CURVA C/MORSET.HTS-HTSW X TUBO D.50 D.50X	CURVE WITH TERMINAL	COURBE AVEC BORNIER	KURVE MIT KLEMM	CURVA CON REGLETERA
11	R58004030	2	DADO INOX 1"1/4X8 M/110-210-220 031010	NUT	ECROU	MUTTER	TUERCA
12	R58004050	2	DADO PER PERNO CERNIERA REG. M/106-220	NUT FOR UPPER DOOR HINGE	ECROU CHEVILLE CHARNIERE SUPERIEURE	MUTTER F. OBERES SCHARNIERSTIFT	TUERCA PARA PERNO BISAGRA SUPERIOR
13	R62060223	2	DADO PILOTA TUBO D.6 0903/1	NUT D.6	ECROU D. 6	MUTTER D.6	DADO D.6
14	R65110200	1	E.V. 1 VIA 220V 50HZ X J.G.CON ATTACC	SOLENOID VALVE	ELECTROVANNE	MAGNETVENTIL	ELECTROVALVULA
15	R65110210	1	E.V. 2 VIE 220V 50HZ X J.G.CON ATTACC	SOLENOID VALVE 220V 50HZ	ELECTROVANNE 220V 50HZ	MAGNETVENTIL 220V 50HZ	ELECTROVALVULA 220V 50HZ
16	R65280490	1	FERRITE TOROIDALE FT36	FERRITE FT36	FERRITE FT36	FERRIT FT36	FERRITA FT36
17	R65280200	3	FILTRO Cx=0,47µF Cy=2X10nF	INTERFERENCE SUPPRESSOR	FILTRE ANTIPARASITES	STOERSCHUTZFILTER	FILTRO
18	R69180250	1	FILTRO SCARICO BACINELLA	DRAIN FILTER	FILTRE ENCEINTE	ABFLUSSFILTER	FILTRO DESAGUE
19	R58003840	1	FLANGIA GUARN.GRANDE	MOTOR GASKET BRASS FLANGE	BRIDE JOINT MOTEUR	FLANSCH F. MOTORDICHTUNG	BRIDA JUNTA MOTOR
20	R70010030	1	GUARNIZIONE OR 6,07 X 1,78 SILICONE	GASKET OR 6,07 X 1,78	JOINT OR 6,07 X 1,78	RINGDICHTUNG OR 6,07 X 1,78	JUNTA OR 6,07 X 1,78
21	R70020050	1	GUARNIZIONE MARK IV MLA 2400.02.05	GASKET	JOINT	RINGDICHTUNG	JUNTA
22	R70010210	1	GUARNIZIONE OR NBR 70 18,72x2,62 C.3075	GASKET 18,72x2,62	JOINT 18,72x2,62	RINGDICHTUNG 18,72x2,62	JUNTA 18,72x2,62
23	R65070230	1	GUARNIZIONE PER TERM.SIC.CA-MERM/106-110	GASKET	JOINT	RINGDICHTUNG	JUNTA
24	R70050150	1	GUARNIZIONE X TAPPO 2" PLAST.G40005	GASKET	JOINT	RINGDICHTUNG	JUNTA
25	R70050140	1	GUARNIZIONE X TAPPO BOYLER PLAST. G40015	GASKET	JOINT	RINGDICHTUNG	JUNTA
26	R65140370	1	KIT INVERSIONE X TELERUTT. 4KW SIEMENS	INVERSION KIT FOR CONTACTOR 4KW	KIT D'INVERSION POUR CONTACTEUR 4KW	KIT WENDEN SCHUETZ 4KW	KIT INVERSION CONTACTOR 4KW
27	R70060080	1	MANICOTTO SILICONE D.13X18X80	SILICON SLEEVE	SILICONE SLEEVE	SILIKONHÜLLE	FUNDA DE SILICONA
28	R70060020	1	MANICOTTO SILICONE D.30X35X9 TAPPO SFIA	SILICON SLEEVE	SILICONE SLEEVE	SILIKONHÜLLE	FUNDA DE SILICONA
29	R70060040	2	MANICOTTO SILICONE D.50X50X3	SILICON SLEEVE	SILICONE SLEEVE	SILIKONHÜLLE	FUNDA DE SILICONA
30	R75300090	1	MASCHERINA VENTILATORE D.350	FAN GUARD GRID D.350	GRILLE VENTILATEUR D.350	VENTILATORSCHUTZGITTER D.350	REJILLA VENTILADOR D.350
31	R65220290	1	MORSETTIERA LX1(TIPO 3)NEW C/TERRA PASS.	TERMINAL BOARD	BORNIER	KLEMMLEISTE	REGLETERA
32	R65040530	1	MOTORE KW 055 F3 4P 3039 200-440V I	MOTOR	MOTEUR	MOTOR	MOTOR
33	R69010260	1	NASELLO 1 STEP 6303-020022	DOOR LATCH 1 STEP	GACHE DE PORTE POUR OUVERTURE SIMPLE	SCHLISSNASE 1 STUFE	NARIZ 1 CIERRE
34	R65240270	2	PASSACAVO F48 GEW GW50432	CABLE/GLAND	RONDELLE FIXATION	ENTZUGLASTUNG	PASACABLE
35	R58003140	2	PERNO AGGANCIO DEFLETTORE	FAN GUARD PANEL PIN	PIVOT DEFLECTEUR	BOLZEN FÜR LUFTLEITBLECH	PERNO CIERRE DEFLECTOR
36	R58000160	2	PERNO FISS.DEFLETTORE K_081-101-A20-201	FAN GUARD PANEL PIN	PIVOT DEFLECTEUR	BOLZEN FÜR LUFTLEITBLECH	PERNO CIERRE DEFLECTOR
37	R58002670	1	PERNO INF.CERNIERA REG.C/FERMI SR.2005	LOWER HINGE PIN	CHEVILLE CHARNIERE INFERIEURE	UNTERES SIE SCHARNIERSTIFT	PERNO INFERIOR BISAGRA

ATTENZIONE: PER ORDINARE I RICAMBI, SPECIFICARE SEMPRE IL MODELLO DI FORNO ED IL NUMERO DI MATRICOLA
ATTENTION: WHEN ORDERING SPARE PARTS, PLEASE ALWAYS SPECIFY THE OVEN MODEL AND THE SERIAL NUMBER

ATTENTION: POUR COMMANDER DES PIÈCES, MERCI DE SPECIFIER TOUJOURS LE MODÈLE DU FOUR ET LE NUMÉRO DE SÉRIE
ACHTUNG: UM ERSATZTEILE ZU BESTELLEN, BITTE IMMER OFEN-MODELL UND SERIENNUMMER GEBEN.

ed. 0713

POS.	COD.	Pz.	DESCRIZIONE	DESCRIPTION	DESCRIPTION	BESCHREIBUNG	DESCRIPCIÓN
38	R58002150	1	PERNO SUP.CERNIERA REG. M/106-220	UPPER HINGE PIN	CHEVILLE CHARNIERE SUPERIEURE	OBERES SCHARNIERSTIFT	PERNO SUPERIOR BISAGRA
39	R58001850	8	PERNO SUPP. PARATIE M5 MIXTER	RACK HOLDER	SUPPORT GLISSIERE	BOLZEN AUFLAGESCHIENEN	PERNO SOPORTE MAMPARO
40	R65210020	3	PORTAFUSIBILE BARRA DIN 5x20	FUSE CARRIER	PORTE-FUSIBLE	SICHERUNGSHALTER	PORTAFUSIBILE
41	R65240030	1	PRESSACAVO PG 107 Z/29 (RACCORDO)	FAIRLEAD	PRESSE CABLE	ZUGENTLASTUNG	PRENSACABLES
42	R65090220	1	PROGRAMMAT. 1 CAMME V220/50HZ 1 CIRCUITO	DAMPER SYSTEM	SORTIE EVAPORATION MOUFLE	DAMPFABLAUSS-STELLMOTOR	MOTOR RESPIRADERO COMPLETO
43	R62090478	2	RACC. INTERMEDIO A GOMITO D.10 PM0310E	ELBOW PIPE FITTING	COURBE AVEC QUEUE	STUCK MIT SCHAFT	RACOR CON CODO
44	R62090458	1	RACC. INTERMEDIO DIRITTO D.10 PM0410E	PIPE FITTING	COURBE	STUCK	RACOR
45	R65110510	1	REGOL. PORTATA ROSSO ALPHATECH. 1.5LT/H	1.5 LT/H WATER FLOW REDUCER	REGULATUER DE DEBIT 1.5 LT.	DURCHFLOSSMONDERER 1.5L/STD.	REGULADOR DE CAUDAL 1.5 LT.
46	R65020350	2	RESISTENZA 7500W 230V BOILER ME/105-106	STEAM GENERATOR HEATING ELEMENT 7500W	RESISTANCE CHAUDIERE 7500W	BOILER HEIZKOERPER 7500W	RESISTENCIA BOILER 7500W
47	R65011310	1	RESISTENZA CIRC.15000W 230V CAMME-VE/110	CHAMBER HEATING ELEMENT 15000W	RESISTANCE MOUFLE 15000W	GARRAUM HEIZKOERPER 15000W	RESISTENCIA CAMARA 15000W
48	R69180100	1	SCATOLA COND. SCARICO H/MV 061-101-201	QUENCHING-DRAIN COLLECTOR	BOITE DE CONDENSATION DECHARGE	KONDENSATION-ABFLUSS SCHACHTEL	CAJON CONDENSACION-DESAGÜE
49	R69180050	1	SCATOLA PLASTICA RAFFREDDAMENTO MOTORE	COLLECTOR	BOITE	SCHACHTEL	CAJON
50	R65260590	1	MICROPORTA	DOOR SWITCH	MICRO PORTE	TUERSCHALTER	MICRO PUERTA
51	R65320220	3	SONDA "K" 6X80 1,5ML. TESTA RASTREM.20mm	PROBE "K" 6X80 1,5ML.	SONDE "K" 6X80 1,5ML.	FUEHLER "K" 6X80 1,5ML.	SONDA "K" 6X80 1,5ML.
52	R65320010	2	SONDA LIVELLO TL 10/B	LEVEL PROBE	SONDE DE NIVEAU	WASSERSSTANDSFUEHLER	SONDA NIVEL
53	R69150110	1	TAPPO FEMMINA G 1"1/4 PP+25%FV NERO	COVER	BOUCHON	ABDECKUNG	TAPON
54	R69150100	1	TAPPO FEMMINA G 2" PP+25%FV NERO	COVER	BOUCHON	ABDECKUNG	TAPON
55	R58005070	1	TAPPO TANICA VERDE x CALOUT	GREEN COVER	VERT BOUCHON	GRÜN ABDECKUNG	TAPON VERDE
56	R65140380	4	TELERUTTORE 3RT1016-1AP02	CONTACTOR	CONTACTEUR	SCHUETZ	CONTACTOR
57	R65140400	3	TELERUTTORE 3RT1025-1AL20 SIEMENS	CONTACTOR	CONTACTEUR	SCHUETZ	CONTACTOR
58	R65160620	1	TERM. MOT.3RU1116-1BB0 1,4-2,0 SIEMENS	THERMIC PROTECTION 3RU1116-1BB0 1,4-2,0	PROTECTION THERMIQUE 3RU1116-1BB0 1,4-2,0	MOTORSCHUTZSCHALTER 3RU1116-1BB0 1,4-2,0	TERMICO 3RU1116-1BB0 1,4-2,0
59	R65070350	1	TERMOSTATO SICUR. 360°C -25K 55.32572.8	THERMOSTAT	THERMOSTAT	THERMOSTAT	TERMOSTATO
60	R65070081	1	TERMOSTATO SICUR. BOILER M/1065532522852	THERMOSTAT	THERMOSTAT	THERMOSTAT	TERMOSTATO
61	R65180420	1	TRASF.RE 20VA 0-220-240/12V MOD.163.16	TRANSFORMER 20VA	TRANSFORMATEUR 20VA	TRANSFORMATOR 20VA	TRANSFORMADOR 20VA
62	R65180430	1	TRASF.RE 40VA 0-220-240/12V MOD.163.82	TRANSFORMER 40VA	TRANSFORMATEUR 40VA	TRANSFORMATOR 40VA	TRANSFORMADOR 40VA
63	R80150000	4	TUBO PE 10MMX7 AZZURRO PM950612E	BLUE PIPE	TUBE	LEITUNG	TUBO
64	R58006160	2	UGELLO COND.D.0,8 CODOLO CIL.10	NOZZLE	BEC	DÜSE	BOQUILLA
65	R65110560	1	VALV. A SFERA MOTOR. 220V 3/4".	STEAM GENERATOR DRAIN MOTORIZED VALVE	DRAINAGE CHAUDIERE	BOILERABLAUFVENTIL	VALVULA DE BOLA MOTORIZADA
65	R65110570	1	VALV. A SFERA MOTOR. 2 VIE 230V 1" DAL 28/01/2103	STEAM GENERATOR DRAIN MOTORIZED VALVE 2 VIE 230V 1" FROM 28/01/2103	DRAINAGE CHAUDIERE 2 VIE 230V 1" DU 28/01/2103	BOILERABLAUFVENTIL 2 VIE 230V 1" VOM 28/01/2103	VALVULA DE BOLA MOTORIZADA 2 VIE 230V 1" DEL 28/01/2103
66	R65060050	2	VENTILATORE COMPATTO D.120 471.5MS 23T	COMPONENTS VENTILATION MOTOR	MOTEUR DE REFRROIDISSMENT	ABKÜHLUNGS MOTOR	MOTOR DE ENFRIAMIENTO
67	R75400440	1	VENTOLA D.350X114/12 50HZ P.D.	FAN	TURBINE	LUEFTERRAD	PALA VENTILADOR
68	R70045010	2	GUARNIZIONE RESISTENZA BOILER	STEAM GENERATOR HEATING ELEMENT GASKET	JOINT DE RESISTENCE POUR CHAUDIERE	DICHTUNG FÜR BOILER HEIZKOERPER	JUNTA RESISTENCIA BOILER
69	R70010130	1	GUARNIZIONE SILICONE ROSSO 80X50 3X3	RED GASKET	JOINT ROUGE	ROTEN DICHTUNG	JUNTA ROJA
70	R58004000	1	VITE FISSAGGIO VENTOLA M12x1,5 SX	FAN SCREW M12x1.5 SX	VIS DE BLOCAGE TURBINE M12x1.5 SX	VENTILATORSCHRAUBE M12x1.5 SX	TORNILLO FIJACION TURBINA M12x1.5 SX
71	R58004010	1	RONDELLA FISSAGGIO VENTOLA D30/12,5	FAN WASHER Ø 30/12.5	RONDELLE TURBINE Ø 30/12.5	UNTERLEGSCHIEBE Ø 30/12.5	ARANDELA FIJACION TURBINA Ø 30/12.5
72	R61020562	1	VITE MOTORE TE A2 M6x55	MOTOR SCREW TE A2 M6x55	VIS DE BLOCAGE MOTEUR TE A2 M6x55	MOTORSCHRAUBE TE A2 M6x55	TORNILLO MOTOR TE A2 M6x55

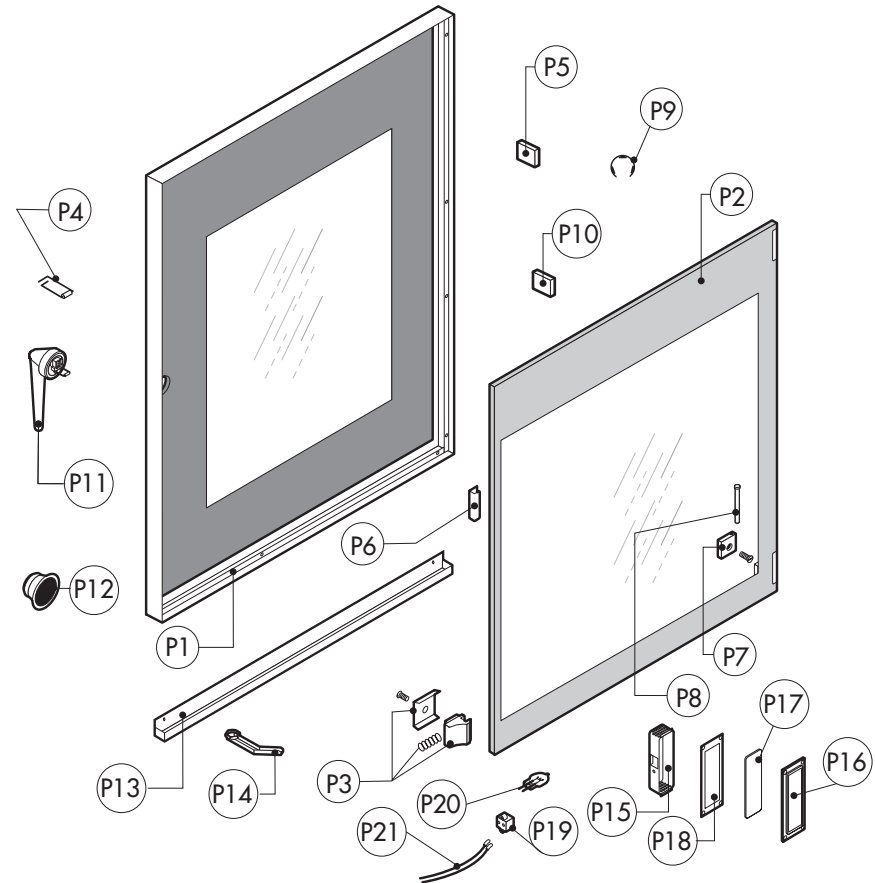
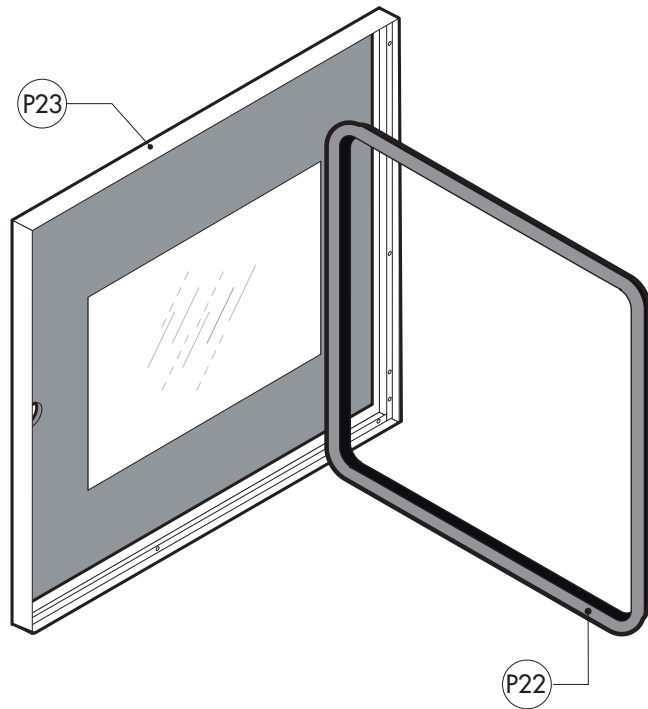

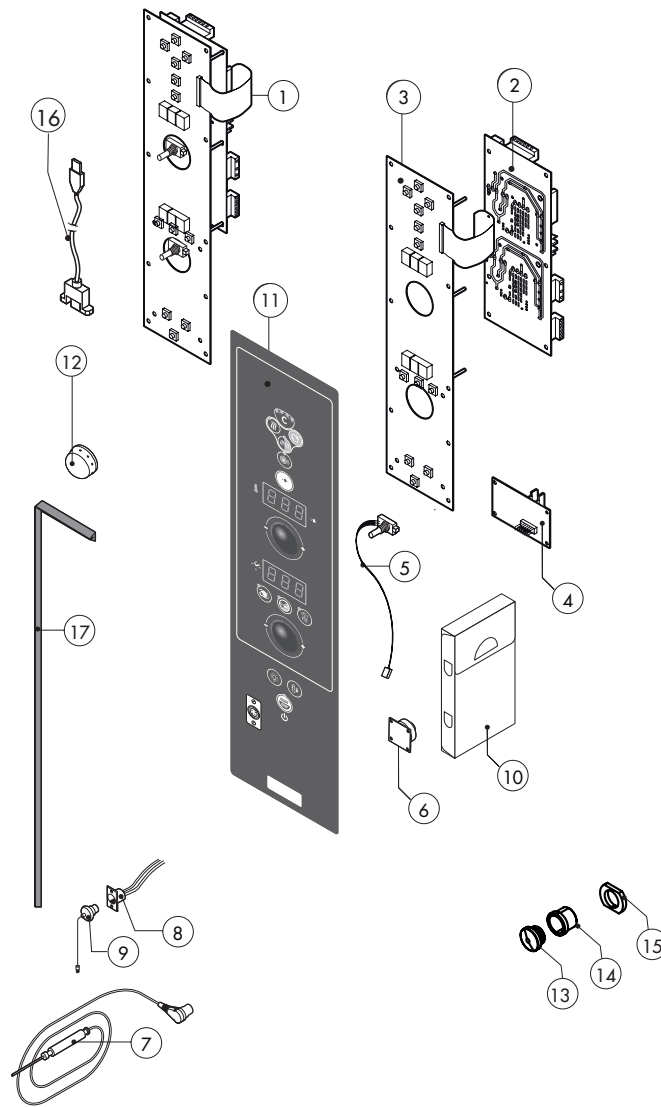

ATTENZIONE: PER TENSIONI SPECIALI, SPECIFICARE SEMPRE IL MODELLO DI FORNO ED IL NUMERO DI MATRICOLA
ATTENTION: FOR SPECIAL VOLTAGES, PLEASE ALWAYS SPECIFY THE OVEN MODEL AND THE SERIAL NUMBER

ATTENTION: POUR TENSIONS SPÉCIALES, MERCI DE SPÉCIFIER TOUJOURS LE MODÈLE DU FOUR ET LE NUMÉRO DE SÉRIE
ACHTUNG: BEI SONDRSPANNUNGEN, BITTE IMMER OFEN-MODELL UND SERIENNUMMER GEBEN.

ed. 0713

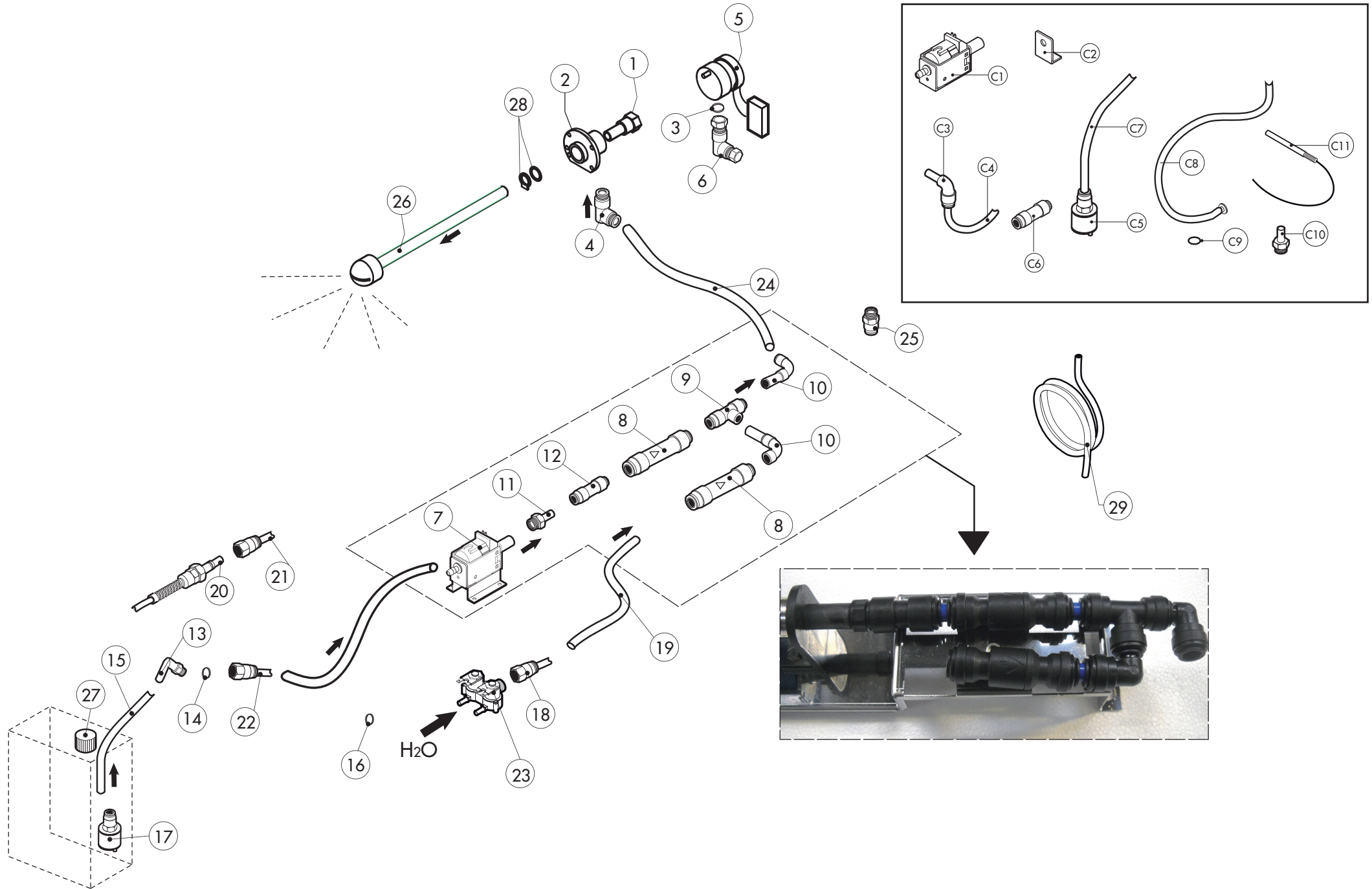

ATTENZIONE: PER ORDINARE I RICAMBI, SPECIFICARE SEMPRE IL MODELLO DI FORNO ED IL NUMERO DI MATRICOLA
ATTENTION: WHEN ORDERING SPARE PARTS, PLEASE ALWAYS SPECIFY THE OVEN MODEL AND THE SERIAL NUMBER

ATTENTION: POUR COMMANDER DES PIÉCES, MERCI DE SPECIFIER TOUJOURS LE MODÈLE DU FOUR ET LE NUMÉRO DE SÉRIE
ACHTUNG: UM ERSATZTEILE ZU BESTELLEN, BITTE IMMER OFEN-MODELL UND SERIENNUMMER GEBEN.

ed. 0713

POS.	COD.	Pz.	DESCRIZIONE	DESCRIPTION	DESCRIPTION	BESCHREIBUNG	DESCRIPCIÓN
1	R58007000	1	PERNO ROTANTE LAVAGGIO MOB	ROTATING PIVOT	PIVOT TOURNANT	UMLAUFENDE STÜTZE	GOZNE ROTATORIO
2	R58007020	1	FLANGIA LAVAGGIO MOB	WASHING SYSTEM FLANGE	BRIDE BRAS DE LAVAGE	FLANSCH WASCHARMBEFESTIGUNG	PLATINA LAVADO
3	R70010080	1	GUARNIZIONE OR 14x2 Viton DIN 981	GASKETS OR 14x2	OR JOINT 14X2	RINGDICHTUNG 14x2	JUNTA OR 14x2
4	R62090663	1	RACCORDO OTTONE NICHALC/OGIVA 10X1/4"	ELBOW PIPE FITTING BRASS D.10x1/4"	RACCORDÉMENT A COUDE LAITON D 10x1/4"	ELBOW PIPE FITTING BRASS D.10x1/4"	RACOR LATON DE GOMA D.10x1/4"
5	R65090250	1	MOTORID.LAV.SAIA-BURGESS 175022044028-A	WASHING GEARED MOTORS	MOTO-REDUCTEURS DE LAVAGE	GETRIEBEMOTOREN	MOTORREDUCTORES LAVADO
6	R62090633	1	RACCORDO OTTONE CURVO 10/10 C/OGIVA	ELBOW PIPE FITTING BRASS D.10	RACCORDÉMENT A COUDE LAITON D 10	WINKELSTUTZEN AUS MESSING D,10	RACOR LATON DE GOMA D.10
7	R65110600	1	POMPA ELETTRON.A PIS.OSC.ET508LAB 2273	POMPE DETERGEANT	DETRGENT PUMP	REINIGERPUMPE	BOMBA DETERGENTE
8	R65110680	2	VALVOLA ANTIRITORNO J.G. 10SCV	ANTI-BACK FLOW	ANTIRETOUR	RUCKFLUSSVERHINDERER	ANTIRETORNO
9	R62090468	1	RACCORDO INTERMEDIO A "T" D.10 PM0210E	T MIDLING PIPE FITTING D.10	RACCORD INTERMEDIAIRE A "T" D.10	MITTELVERBINDUNGSSTUCK D.10 "T"- FORMIG	RACOR INTERMEDIO TIPO "T" D.10
10	R62090528	4	RACC.A GOMITO C/CODOLO 10X10 PM221010E	ELBOW PIPE FITTING (WITH TANG) 10 X 10	COURBE AVEC QUEUE 10x10	WINKELVERBINDUNGSSTUCK 10 X 10 MIT SCHAFT	RACOR DE GOMA CON CODO 10x10
11	R62090608	2	TERMINALE C/CODOLO 8x1/8" PM050811E	8X1/8 END SIDE PIPE FITTING (WITH TANG)	RACCORD AVEC QUEUE 8x1/8"	ENDVERBINDUNGSSTUCK 8 X 1/8" MOT SCHAFT	RACOR TERMINAL CON CODO 8x1/8"
12	R62090618	1	RIDUZIONE INTERMEDIA 10-8 PM201008E	REDUCTION PIPE FITTING	RACCORD DROIT REDUCTION	GERADE ANSCHLUSS-VERKLEINERUNG	RACOR DERECHO REDUCCION
13	R62090678	2	RACC.A GOMITO C/CODOLO 8X8 PM220808E	ELBOW PIPE FITTING (WITH TANG) 8 X 8	COURBE AVEC QUEUE 8x8	WINKELVERBINDUNGSSTUCK 8X8 MIT SCHAFT	RACOR DE GOMA CON CODO 8x8
14	R70010050	4	GUARNIZIONE OR 7,60 X 2,62 OR 3030 NB	GASKET OR 7,60x2,62	OR JOINT	RINGDICHTUNG 7,60X2,62	JUNTA OR 7,60x2,62
15	R80150020	2m	TUBO DETERGENTE PE D.8mm x 6	PE D.8 MM X 6 DETERGENT FLEXIBLE PIPE	TUBE DETERGEANT D. 8x6	ROHRLEITUNG F. REINIGER PE D.8MMX6 (2MT)	TUBO DETERGENTE PE D.8mm X 6
16	R11401840	14	RONDELLA 18/13 sp.6/10	WASHER	RONDELLE	UNTERLEGSCHIBE	ARANDELA
17	R65110650	1	VALVOLA DI FONDO PER FILTRO GM.060.35	BOTTOM FILTER	FILTER POUR TUBE DETERGEANT	ANSAUGFILTER F. REINIGUNGSSCHAUCH	VÁLVULA DE FONDO TUBO DEL LIMPIADOR
18	R62020118	1	NIPPLES MASCHIO CONICO 1/4" PNID020200	STRAIGHT THREADED TERMINAL PIPE FITTING	RACCORD FILET DROIT	ENDVERBINDUNGSSTUCK GESCHNITTEN	RACOR TERMINAL DERECHO ROSCADO
19	R80120060	1	TUBO SILC. TRASP.SR60/TR 7/12.	PIPE	TUBE	LEITUNG	TUBO
20	R62090482	1	RACC.RAPIDO MASCHIO X LAVAG. PIPU40-C08M	RAPID MALE PIPE FITTING	RACCORD RAPIDE PARTIE MALE	SCHNELLVERBINDUNG MANNL	RACOR RAPIDO MACHO
21	R62090638	1	RACC.RAP.FEMM.X LAV.FIL.FEMM PVP40-F1/4	RAPID FEMALE PIPE FITTING	RACCORD RAPIDE PARTIE FEMELLE	SCHNELLVERBINDUNG	RACOR RAPIDO HEMBRA
22	R62090538	1	RACC.DIR.F.1/4" TUBO 6X8 A CALZ. PRCF220008	1/4" FEMALE STRAIGHT PIPE FITTING FOR D.6X8 PIPE	RACCORD DROIT PARTIE FEMELLE 1/4" TUBE 6x8	VERBINDUNGSSTUCK 1/4" WEBL. FUR ROHR D.6X8	RACOR DERECHO HEMBRA 1/4" PARA TUBO D.6x8
23	R65110210	1	E.V. 2 VIE 220V 50HZ X J.G.CON ATTACC	SOLENOID VALVE 220V 50HZ	ELECTROVANNE 220V 50HZ	MAGNETVENTIL 220V 50HZ	ELECTROVALVULA 220V 50HZ
24	R80150000	1	TUBO PE D.10mm x 7 AZZURRO	PE D.10 MM X7 WATER FLEXIBLE PIPE	TUBE FLEXIBLE EAU D. 10x7	WASSERFLEXROHRLEITUNG PE D.10MMX7	TUBO FLEXIBLE AGUA PE D.10mm X 7
25	R62090688	2	RACC.TERMIN.DIR.FIL.CON.8X1/4 NC2500-P	8x1/4 STRAIGHT THREADED TERMINAL PIPE FITTING	RACCORD FILET DROIT 8x1/4"	ENDVERBINDUNGSSTUCK 8x1/4" GESCHNITTEN	RACOR TERMINAL DERECHO ROSCADO 8x1/4"
26	R58007030	1	TESTA LAVAGGIO MOB+ALBERO L=165	WASHING SYSTEM INNER ASSEMBLY	ENSEMBLE INTERIEUR DU LAVAGE	INNEN WASCHARMBEFESTIGUNG	KIT INTERNO LAVADO
27	R58005060	1	TAPPO TANICA GIALLO x LAVAGGIO	COVER	BOUCHON	ABDECKUNG	TAPON
28	R70045120	1	KIT GUARNIZIONI X LAVAGGIO MOB	GASKETS KIT	ENSEMBLE JOINTS	DICHTUNGSSATZ	KIT JUNTAS
29	R70070080	1m	TUBO CARICO ACQUA D.23mm x13	PIPE	TUBE	LEITUNG	TUBO
C1	R65110620	1	POMPA ELETTRON.A PIS.OSC.HF 230V/50HZ	PUMP	POMPE	PUMPE	POMPA
C2	R65110630	2	SUPPORTO ELLE POMPA HF	PUMP HOLDER	SUPPORT POUR POMPE	GESTELL FUER PUMPE	SOPORTE PARA POMPA
C3	R62090808	1	GOMITO CON CODOLO ø6-ø6 PM220606E	ELBOW PIPE FITTING	COURBE AVEC QUEUE	WINKELVERBINDUNGSSTUCK MIT SCHAFT	RACOR DE GOMA CON CODO
C4	R80150050	1,6m	TUBO PE 6MMX4	WATER FLEXIBLE PIPE	TUBE FLEXIBLE EAU	WASSERFLEXROHRLEITUNG	TUBO FLEXIBLE AGUA
C5	R65110650	1	VALVOLA DI FONDO PER FILTRO GM.060.35	VALVE	DRAINAGE	ABLAUFVENTIL	VALVULA
C6	R62090798	2	RIDUZIONE INTER.DRITTA ø8-ø6 PM200806E	REDUCTION	REDUCTION	VERRINGERUNG	REDUCCION
C7	R80150020	2	TUBO PE 8MMX6 TRASPARENTE	WATER FLEXIBLE PIPE	TUBE FLEXIBLE EAU	WASSERFLEXROHRLEITUNG	TUBO FLEXIBLE AGUA
C8	R11429630	1	TUBO INGRESSO ANTICALCARE BOILER CAL-OUT	CALOUT FLEXIBLE PIPE	TUBE FLEXIBLE POUR CALOUT	CALOUT FLEXROHRLEITUNG	TUBO FLEXIBLE CALOUT
C9	R62070023	1	BICONO PILOTA TUBO D.6 905	BICONE D.6	BICONE D.6	KEGEL D.6	BICONO D.6
C10	R62060223	1	DADO PILOTA TUBO D.6 0903/1	NUT D. 6	ECROU D. 6	MUTTER D.6	DADO D.6
C11	R65324550	1	SONDA LIVELLO CALOUT TL 10/B EL=20 TF=15	LEVEL PROBE	SONDE DE NIVEAU	WASSERSSTANDSFUEHLER	SONDA NIVEL

TAV. D

KME 101 S