

Dishwashing Machine

Model B-US-28X-LPW-CSS-TOP

Spare Parts List

MEIKO US

INDEX

	PAGE
01.01 WASH PUMP 2,2KW CRNI, 60HZ.....	5
02.01 WASH SYSTEM - 5 WASH ARMS ABOVE / 4 WASH ARMS BELOW.....	7
03.01 PUMP FINAL RINSE - PUMP	9
04.01 PUMP FINAL RINSE - RINSE ARM	10
05.01 FRESH WATER FINAL RINSE –RINSE ARMS (B-US281)	11
05.02 FRESH WATER FINAL RINSE –RINSE ARMS (B-US282)	12
06.01 CSS SYSTEM - PUMP 0,73 KW - 197-292/340-504V 60HZ.....	13
06.02 CSS-SYSTEM - RINSE ARM.....	15
06.03 CSS-SYSTEM - RINSE ARM.....	16
07.01 CSS PLUS.....	17
08.01 FEET OF MACHINE.....	18
09.01 DOOR HEIGHT 3	19
09.02 DOOR HEIGHT 3	20
10.01 CURTAIN	21
11.01 COVERING SIEVE - INFEED / CSS	22
11.02 TANK COVERING SIEVE	23
12.01 DRAIN	24
13.01 FLOAT SWITCH	25
14.01 WATER SAVING DEVICE	26
15.01 FINAL SWITCH DEVICE	28
16.01 TRANSPORT CONVEYOR.....	29
16.03 TRANSPORT BELT, T108.....	30
17.01 BELT DRIVE	31
20.01 CHAIN WHEEL	33
21.01 REVERSE UNIT	34
22.01 EXTRACTION FAN Ø400	35
24.01 DRYING (STEAM HEATED).....	36



24.02 DRYING (ELECTRICALLY HEATED)	37
22.5.2 BOILER ELT., EXTERNAL THERMOSTAT REGULATION.....	38
22.5.2 BOILER ELT., EXTERNAL THERMOSTAT REGULATION.....	39

01.01 WASCHPUMPE 2,2KW CRNI, 60HZ



01.01 WASH PUMP 2,2KW CRNI, 60HZ

01.01 POMPE DE LAVAGE 2,2KW CRNI, 60HZ

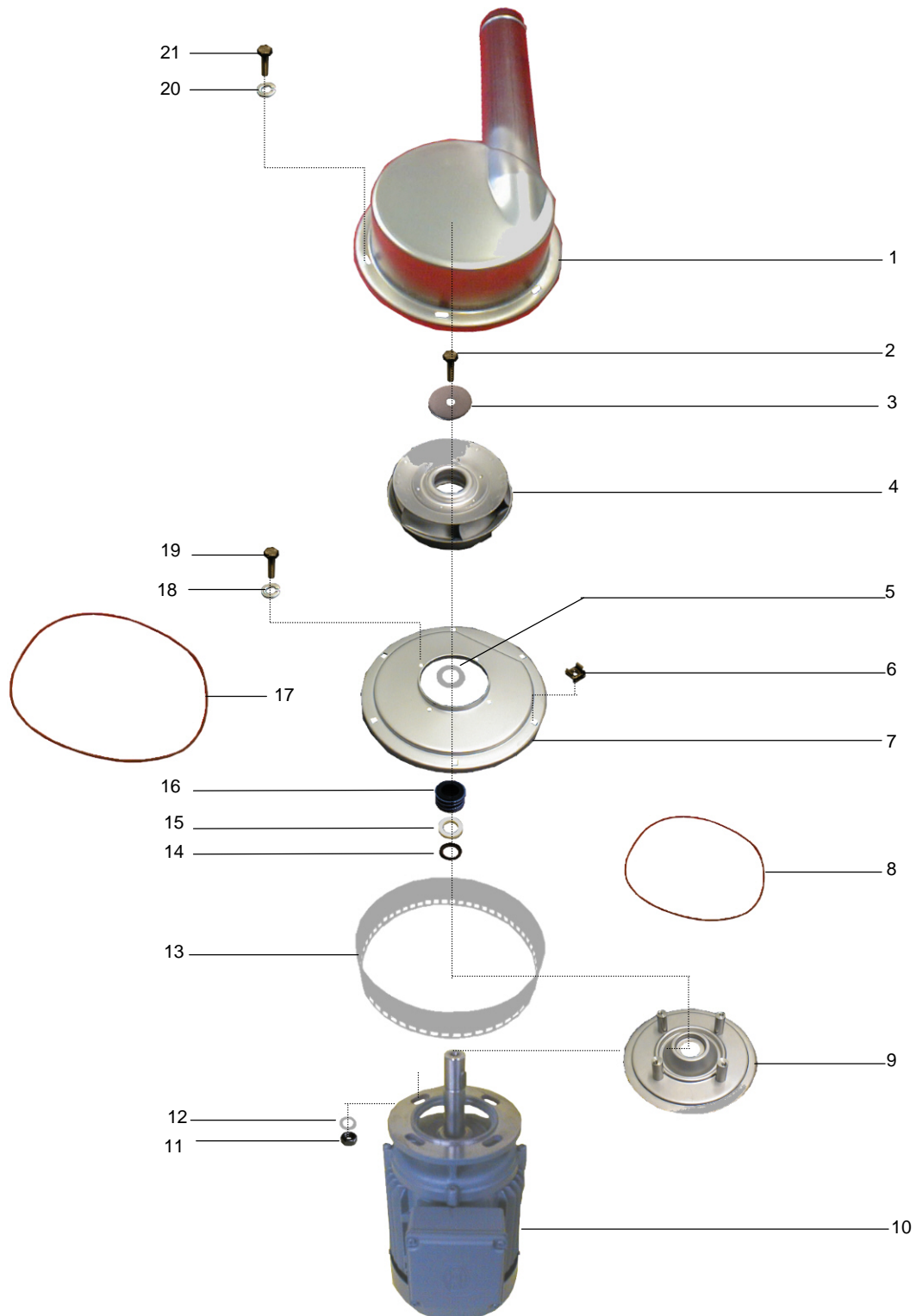

01.01 WASCHPUMPE 2,2KW CRNI, 60HZ

01.01 WASH PUMP 2,2KW CRNI, 60HZ

01.01 POMPE DE LAVAGE 2,2KW CRNI, 60HZ



POS	IDENT. NR. IDENT. NO.	BEZEICHNUNG	DESIGNATION	DESIGNATION	
	1	9521177	PUMPENDECKEL KPL.	PUMP LID CPL.	COUVERCLE DE POMPE CPL.
	2	0302002	SECHSKANTSCHRAUBE M6X20	HEXAGON SCREW M6X20	VIS A 6 PANS M6X20
	3	8100251	U-SCHEIBE Ø34X7-2	WASHER Ø34X7-2	RONDELLE Ø34X7-2
W (1)	4	9532883	PUMPENRAD Ø120 FÜR PUMPE 2,2KW 60HZ	PUMP WHEEL Ø120 FOR PUMP 2,2KW 60HZ	ROUE DE POMPE Ø120 POUR POMPE 2,2KW 60HZ
	5	8100131	U-SCHEIBE Ø38XØ24,1X1	WASHER Ø38XØ24,1X1	RONDELLE Ø38XØ24,1X1
	6	9500056	KÄFIGMUTTER M6 1.4301	NUT M6 1.4301	ECROU M6 1.4301
	7	9500054	PUMPENBODEN	PUMP BASE	FOND DE POMPE
W (5)	8	9500177	RUNDDICHTRING Ø1610X3 EPDM	GASKET Ø161X3 EPDM	JOINT Ø161X3 EPDM
	9	8103179	MOTORTRÄGER	MOTOR SUPPORT	SUPPORT DE MOTEUR
W (1)	10	MOTOR SIEHE ELEKTROSCHALTPLAN	PUMP MOTOR SEE ELECTRIC WIRING DIAGRAM	MOTEUR VOIR SCHEMA ELECTRIQUE	
	11	0335015	SECHSKANTMUTTER M8	HEXAGON NUT M8	ECROU A 6 PANS M8
	12	0340006	U-SCHEIBE MS. VERN. 8,4X18X2MM	WASHER BRASS NICKELED 8,4X18X2MM	RONDELLE 8,4X18X2MM
	13	8103177	ANSAUGSIEB	SUCTION SIEVE	FILTRE D'ASPIRATION
W (5) V	14	0403009	GLEITRING-MANSCHETTE	COLLAR PERBUNAN	MANCHETTE PEBUNAN
W (5) V	15	0403010	GLEITRING KERAMIK	SLIDING SEAL CERAMICS	JOINT AXIAL CERAMIQUE
W (5) V	16	0403003	GLEITRINGDICHTUNG VITON	SLIDING SEAL	JOINT AXIAL
W (5)	17	9500178	RUNDDICHTRING Ø220X3,5 EPDM	GASKET Ø220X3,5 EPDM	JOINT Ø220X3,5 EPDM
	18	0341012	FEDERRING 6MM	SPRING RING 6MM	RESSORT 6MM
	19	0302055	SECHSKANTSCHRAUBE M6X12	HEXAGON SCREW M6X12	VIS A 6 PANS M6X12
	20	0340010	U-SCHEIBE 6,3X16X1,5MM	WASHER 6,3X16X1,5MM	RONDELLE 6,3X16X1,5MM
	21	0302001	SECHSKANTSCHRAUBE M6X15	HEXAGON SCREW M6X15	VIS A 6 PANS M6X15

02.01 WASCHSYSTEM - 5 ARME OBEN / 4 ARME UNTEN



02.01 WASH SYSTEM - 5 WASH ARMS ABOVE / 4 WASH ARMS BELOW

02.01 SYSTEME DE LAVAGE - 5 BRAS DE LAVAGE SUP. / 4 BRAS DE LAVAGE INF.

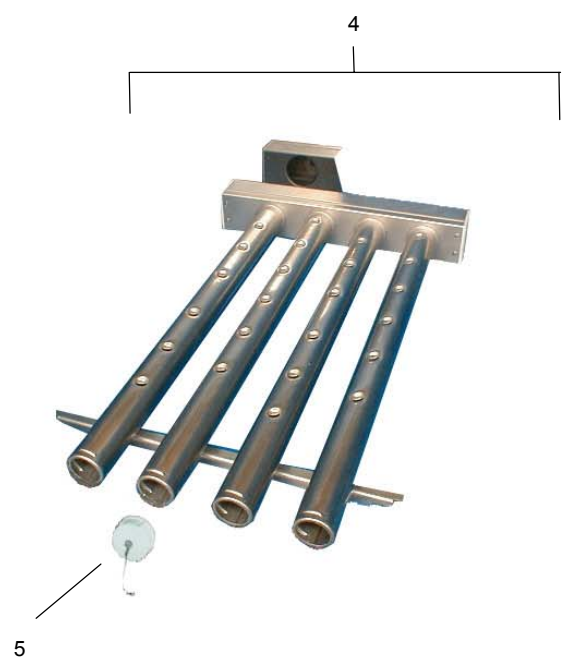
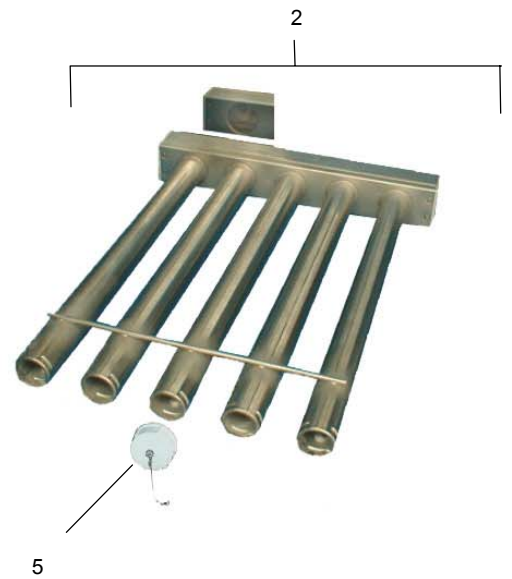

02.01 WASCHSYSTEM - 5 ARME OBEN / 4 ARME UNTEN



02.01 WASH SYSTEM - 5 WASH ARMS ABOVE / 4 WASH ARMS BELOW

02.01 SYSTEME DE LAVAGE - 5 BRAS DE LAVAGE SUP. / 4 BRAS DE LAVAGE INF.

POS	IDENT. NR. IDENT. NO.	BEZEICHNUNG	DESIGNATION	DESIGNATION	
1	9549529-01	WASCHSYSTEM OBEN KPL. L-R BREITE 5	UPPER WASH SYSTEM CPL. L-R WIDTH 5	SYSTEME DE LAVAGE SUP. CPL. G-D LARGEUR 5	
2	9549529-02	WASCHSYSTEM OBEN KPL. R-L BREITE 5	UPPER WASH SYSTEM CPL. R-L WIDTH 5	SYSTEME DE LAVAGE SUP. CPL. D-G LARGEUR 5	
3	9549531-01	WASCHSYSTEM UNTEN KPL. L-R BREITE 5	LOWER WASH SYSTEM CPL. L-R WIDTH 5	SYSTEME DE LAVAGE INF. CPL. G-D LARGEUR 5	
4	9549531-02	WASCHSYSTEM UNTEN KPL. R-L BREITE 5	LOWER WASH SYSTEM CPL. R-L WIDTH 5	SYSTEME DE LAVAGE INF. CPL. D-G LARGEUR 5	
* (10)	5	9548850	VERSCHLUSSKAPPE MIT DRAHTSEILSICHERUNG	CLOSING CAP WITH SAFETY CABLE	CAPOUCHON AVEC CABLE METALLIQUE D'ARRET
		9521983	DROSSELBLECH FÜR WASCHSYSTEM OBEN	THROTTLE PLATE FOR UPPER WASH SYSTEM	TOLE D'ETRANGLEMENT POUR SYSTEME DE LAVAGE SUP.
		9524985	DROSSELBLECH FÜR WASCHSYSTEM UNTEN	THROTTLE PLATE FOR LOWER WASH SYSTEM	TOLE D'ETRANGLEMENT POUR SYSTEME DE LAVAGE INF.



03.01 PUMPENNACHSPÜLUNG - PUMPE



03.01 PUMP FINAL RINSE - PUMP

03.01 RINCAGE FINAL A POMPE - POMPE

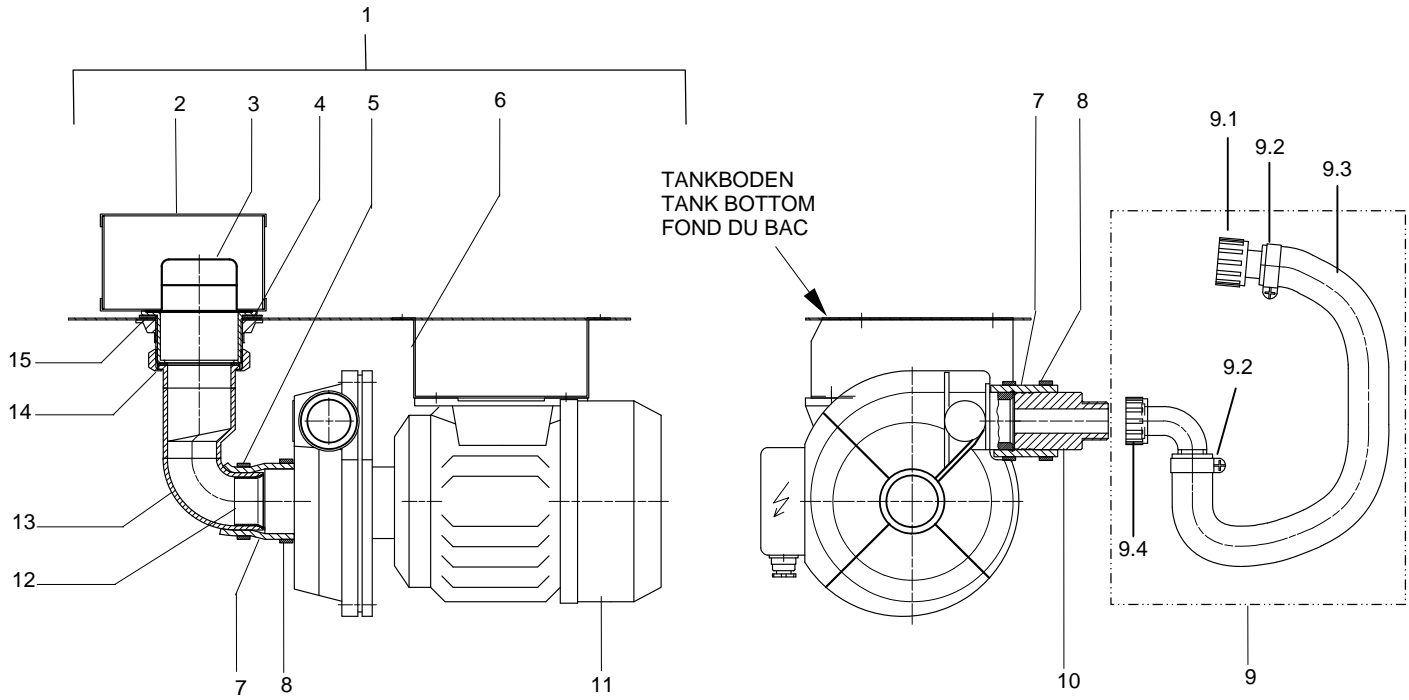

03.01 PUMPENNACHSPÜLUNG - PUMPE

03.01 PUMP FINAL RINSE - PUMP

03.01 RINCAGE FINAL A POMPE - POMPE



POS	IDENT. NR. IDENT. NO.	BEZEICHNUNG	DESIGNATION	DESIGNATION	
1		PUMPENKLARSPÜLUNG KPL.	PUMP FINAL RINSE CPL.	RINCAGE FINAL A POMPE CPL.	
2	8101229	ANSAUGSIEB-PUMPENNACH- SPÜLUNG	PUMP FINAL RINSE-SIEVE BASKET	FILTRE INOX P. POMPE DE RINCAGE; PARTIE II SUP.	
3	0237095	ANSAUGSIEB F. PUMPENNACH- SPUELUNG 1.4301 434125030	SUCTION SIEVE F. PUMP FINAL RINSE	FILTRE INOX A. MANCHON FILETE P. POMPE RINCAGE	
4	0237008	STANDR.VENT.-MUTTER 9942 2" X 88 MM MS.	NUT. NO. 9942 MS 2 " X 88 MM	ECROU NO. 9942 MS 2 " X 88 MM	
5	0233046	NORMA-KLEMME 32-50	HOSE CLAMP 32-50	COLLIER DE TUYAU 32-50	
6	8100295	MOTORKONSOLE	MOTOR CONSOLE	CONSOLE DE MOTEUR	
W (5)	7	8100538	SCHLAUCH Ø40X5X50	HOSE Ø40X5X50	TUYAU Ø40X5X50
W (5)	8	0233041	SCHLAUCHKLEMME 40-60	HOSE WIRE CLAMP 40-60	COLLIER DE SERRAGE 40-60
W (2)	9	9530375	SCHLAUCH Ø40X5X50	HOSE Ø40X5X50	TUYAU Ø40X5X50
	9.1	0621028	SCHLAUCHNIPPEL 19X63X3/4"	HOSE NIPPLE 19X63X3/4"	NIPPLE DE TUYAU 19X63X3/4"
	9.2	0233045	SCHLAUCHKLEMME SX 9 20-32 C7-W2	HOSE WIRE CLAMP SX 9 20-32 C7-W2	COLLIER DE SERRAGE SX 9 20-32 C7-W2
W (2)	9.3	9547550	SCHLAUCH 3/4"X1010	HOSE 3/4"X1010	TUYAU 3/4"X1010
	9.4	9501740	BOGEN 3/4"X20	CURVE 3/4"X20	COURBE 3/4"X20
	10	9506752	VERBINDUNGSTEIL	CONNECTION PIECE Ø40-65	PIECE DE CONNEXION Ø40-65
W (1)	11	NACHSPÜLPUMPE SIEHE ELEKTROSCHALTPLAN	FINAL RINSE PUMP SEE ELECTRIC WIRING DIAGRAM	POMPES DE LAVAGE VOIR SCHEMA ELECTRIQUE	
	12	8000542	VERSTÄRKUNGSRING Ø33,7X1X20	SUPPORT RING Ø33,7X1X20	BAGUE DE SUPPORT Ø33,7X1X20
	13	8101337	ANSAUGSTUTZEN PU-NS BAUGRUPPE	SUCTION PORT PUMP FINAL RINSE	MANCHON D'ASPIRATION
W (2)	14	0293010	GUMMIDICHTUNG 891.340.00.0	RUBBER PACKING 891.340.00	JOINT CAOUCHOUK 891.340.00.0
V					
W (2)	15	0237009	DICHTUNG 2" 59,5X85X2MM	PACKING 2" 59,5X85X2MM	JOINT 2" 59,5X85X2MM
V					

POS. 3.1 PUMPENKLARSPÜLUNG



POS. 3.1 PUMP FINAL RINSE

POS. 3.1 RINCAGE FINAL A POMPE

POS.	IDENT.-NR. IDENT.-NO.	BEZEICHNUNG	DESIGNATION	DESIGNATION
1	8101229	ANSAUGSIEB-PUMPENNACH- SPÜLUNG	PUMP FINAL RINSE-SIEVE BASKET	FILTRE INOX P. POMPE DE RINCAGE; PARTIE II SUP.
2	0237095	ANSAUGSIEB F. PUMPENNACH- SPÜELUNG 1.4301 434125030	SUCTION SIEVE F. PUMP FINAL RINSE	FILTRE INOX A. MANCHON FILETE P. POMPE RINCAGE
3	0237008	STANDR.VENT.-MUTTER 9942 2" X 88 MM MS.	NUT. NO. 9942 MS 2" X 88 MM	ECROU NO. 9942 MS 2" X 88 MM
4	0233046	NORMA-KLEMME 1348030041 32-50 MM 9 MM	HOSE CLAMP 32-50	COLLIER DE TUYAU 32-50
5	8100295	MOTORKONSOLE 140X119X*56	MOTOR CONSOLE 252 X 140 = 1,25	CONSOLE DE MOTEUR 252 X 140 = 1,25
6	8100538	SCHLAUCH Ø40X5X50	HOSE Ø40X5X50	TUYAU Ø40X5X50
7	0233041	SCHLAUCHKLEMME 40-60	HOSE WIRE CLAMP 40-60	COLLIER DE SERRAGE 40-60
8	9530375	SCHLAUCH Ø40X5X50	HOSE Ø40X5X50	TUYAU Ø40X5X50
9	9506752	VERBINDUNGSTEIL Ø40-60	CONNECTION PIECE Ø40-60	PIECE DE CONNEXION Ø40-60
10	9528119	PUMPE TYP 1276 197-292/340-504V+/-5%60HZ	FINAL RINSE PUMP TYPE 1276 197-292/340-504V+/-5%60HZ	POMPES DE LAVAGE TYPE 1276 197-292/340-504V+/-5%60HZ
11	8000542	VERSTÄRKUNGSRING Ø33,7X1X20	SUPPORT RING Ø33,7X1X20	BAGUE DE SUPPORT Ø33,7X1X20
12	8101337	ANSAUGSTUTZEN PU-NS BAUGRUPPE	SUCTION PORT PUMP FINAL RINSE	MANCHON D'ASPIRATION
13	0293010	GUMMIDICHTUNG 891.340.00.0	RUBBER PACKING 891.340.00	JOINT CAOUCHOUK 891.340.00.0
14	0237009	DICHTUNG 2" 59,5X85X2MM	PACKING 2" 59,5X85X2MM	JOINT 2" 59,5X85X2MM

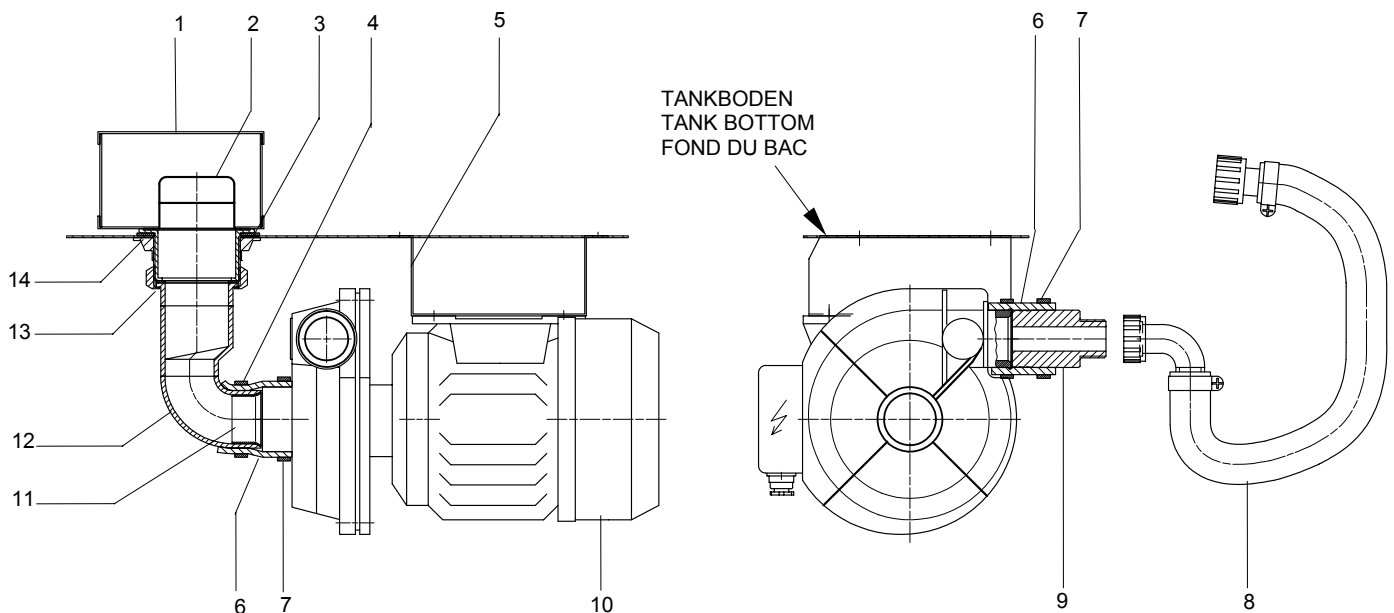

03.01 PUMPENNACHSPÜLUNG - PUMPE



03.01 PUMP FINAL RINSE - PUMP

03.01 RINCAGE FINAL A POMPE - POMPE

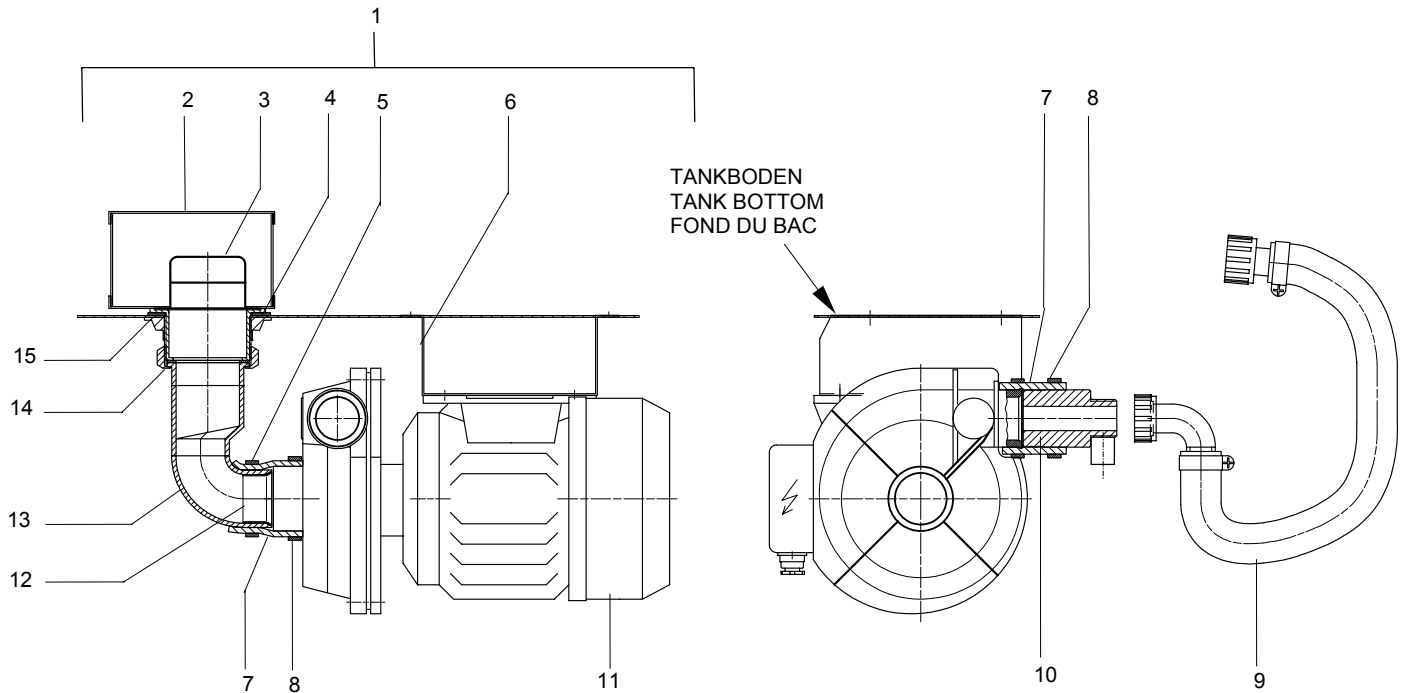

POS	IDENT. NR. IDENT. NO.	BEZEICHNUNG	DESIGNATION	DESIGNATION	
		PUMPENKLARSPÜLUNG KPL.	PUMP FINAL RINSE CPL.	RINCAGE FINAL A POMPE CPL.	
23	8101229	ANSAUGSIEB-PUMPENNACH- SPÜLUNG	PUMP FINAL RINSE-SIEVE BASKET	FILTRE INOX P. POMPE DE RINCAGE; PARTIE II SUP.	
24	0237095	ANSAUGSIEB F. PUMPENNACH- SPÜLUNG 1.4301 434125030	SUCTION SIEVE F. PUMP FINAL RINSE	FILTRE INOX A. MANCHON FILETE P. POMPE RINCAGE	
25	0237008	STANDR.VENT.-MUTTER 9942 2" X 88 MM MS.	NUT. NO. 9942 MS 2" X 88 MM	ECROU NO. 9942 MS 2" X 88 MM	
26	0233046	NORMA-KLEMME 32-50	HOSE CLAMP 32-50	COLLIER DE TUYAU 32-50	
27	8100295	MOTORKONSOLE	MOTOR CONSOLE	CONSOLE DE MOTEUR	
W (5)	28	8100538	SCHLAUCH Ø40X5X50	HOSE Ø40X5X50	TUYAU Ø40X5X50
W (5)	29	0233041	SCHLAUCHKLEMME 40-60	HOSE WIRE CLAMP 40-60	COLLIER DE SERRAGE 40-60
W (2)	30	9530375	SCHLAUCH Ø40X5X50	HOSE Ø40X5X50	TUYAU Ø40X5X50
31	9506752	VERBINDUNGSTEIL	CONNECTION PIECE Ø40-65	PIECE DE CONNEXION Ø40-65	
W (1)	32	NACHSPÜLPUMPE SIEHE ELEKTROSCHALTPLAN	FINAL RINSE PUMP SEE ELECTRIC WIRING DIAGRAM	POMPES DE LAVAGE VOIR SCHEMA ELECTRIQUE	
33	8000542	VERSTÄRKUNGSRING Ø33,7X1X20	SUPPORT RING Ø33,7X1X20	BAGUE DE SUPPORT Ø33,7X1X20	
34	8101337	ANSAUGSTUTZEN PU-NS BAUGRUPPE	SUCTION PORT PUMP FINAL RINSE	MANCHON D'ASPIRATION	
W (2) V	35	0293010	GUMMIDICHTUNG 891.340.00.0	RUBBER PACKING 891.340.00	JOINT CAOUCOUK 891.340.00.0
W (2) V	36	0237009	DICHTUNG 2" 59,5X85X2MM	PACKING 2" 59,5X85X2MM	JOINT 2" 59,5X85X2MM

04.01 PUMPENNACHSPÜLUNG - SPÜLARM



04.01 PUMP FINAL RINSE - RINSE ARM

04.01 RINCAGE FINAL A POMPE - BRAS DE RINCAGE

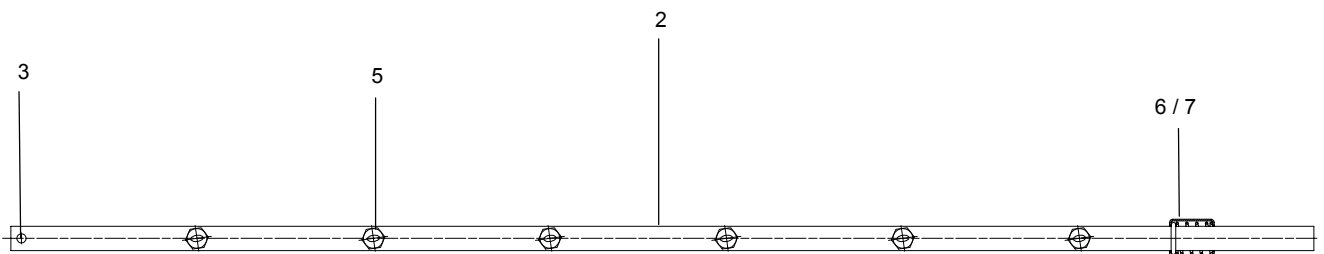
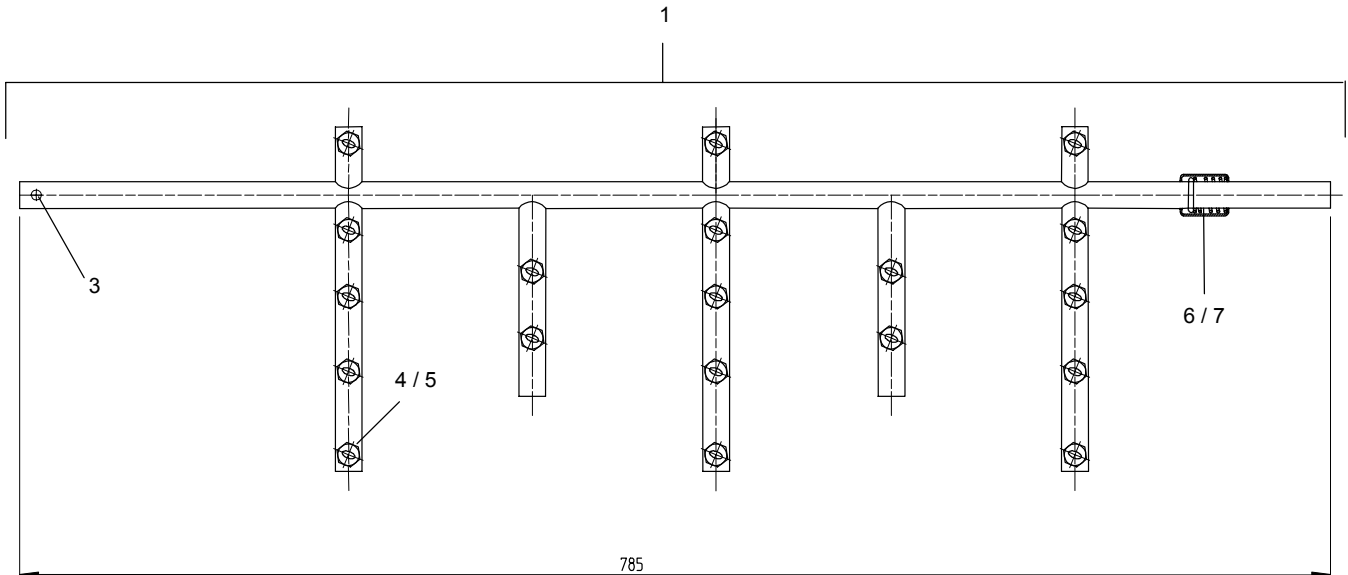

POS	IDENT. NR. IDENT. NO.	BEZEICHNUNG	DESIGNATION	DESIGNATION
1	9550937-01	PNSP-ARM OBEN KPL. L-R BREITE 5 L=785 19 DÜSEN	UPPER FINAL RINSE ARM L-R WIDTH 5 L=785 19 NOZZLES	BRAS DE RINCAGE FINAL SUP. G-D LARGEUR 5 L=785, 19 CAPUCHON
	9550937-02	PNSP-ARM OBEN KPL. R-L BREITE 5 L=785 19 DÜSEN	UPPER FINAL RINSE ARM R-L WIDTH 5 L=785 19 NOZZLES	BRAS DE RINCAGE FINAL SUP. D-G LARGEUR 5 L=785, 19 CAPUCHON
2	9534599	PNSP-ARM UNTEN KPL. BREITE 5 L=849 6 DÜSEN	LOWER FINAL RINSE ARM WIDTH 5 L=849 6 NOZZLES	BRAS DE RINCAGE FINAL INF. LARGEUR 5 L=849 6 CAPUCHON
3	0360215	STIFT Ø6X16	PIN Ø6X16	BROCHE Ø6X16
* (5) W (10)	0472035	DÜSE 1/16" NPT 8020 SS ELP V2A 2,0	NOZZLE 1/16" NPT 8020 SS ELP V2A 2,0	GICLÉUR 1/6" NPT 8020 SS ELP V2A 2,0
	0472034	DÜSE 1/16" NPT 8012 SS ELP V2A 1,2	NOZZLE 1/16" NPT 8012 SS ELP V2A 1,2	GICLÉUR 1/6" NPT 8012 SS ELP V2A 1,2
	9500279	DRUCKFEDER VD 208	PRESSURE SPRING VD 208	RESSORT VD 208
	8103312	FEDERBUCHSE	SPRING BUSHING	BOITIER DU RESSORT

05.01 FRISCHWASSERNACHSPÜLUNG – SPÜLARM (B-US281)



05.01 FRESH WATER FINAL RINSE – RINSE ARMS (B-US281)

05.01 RINCAGE FINAL A L'EAU CLAIRE – BRAS DE LAVAGE (B-US281)

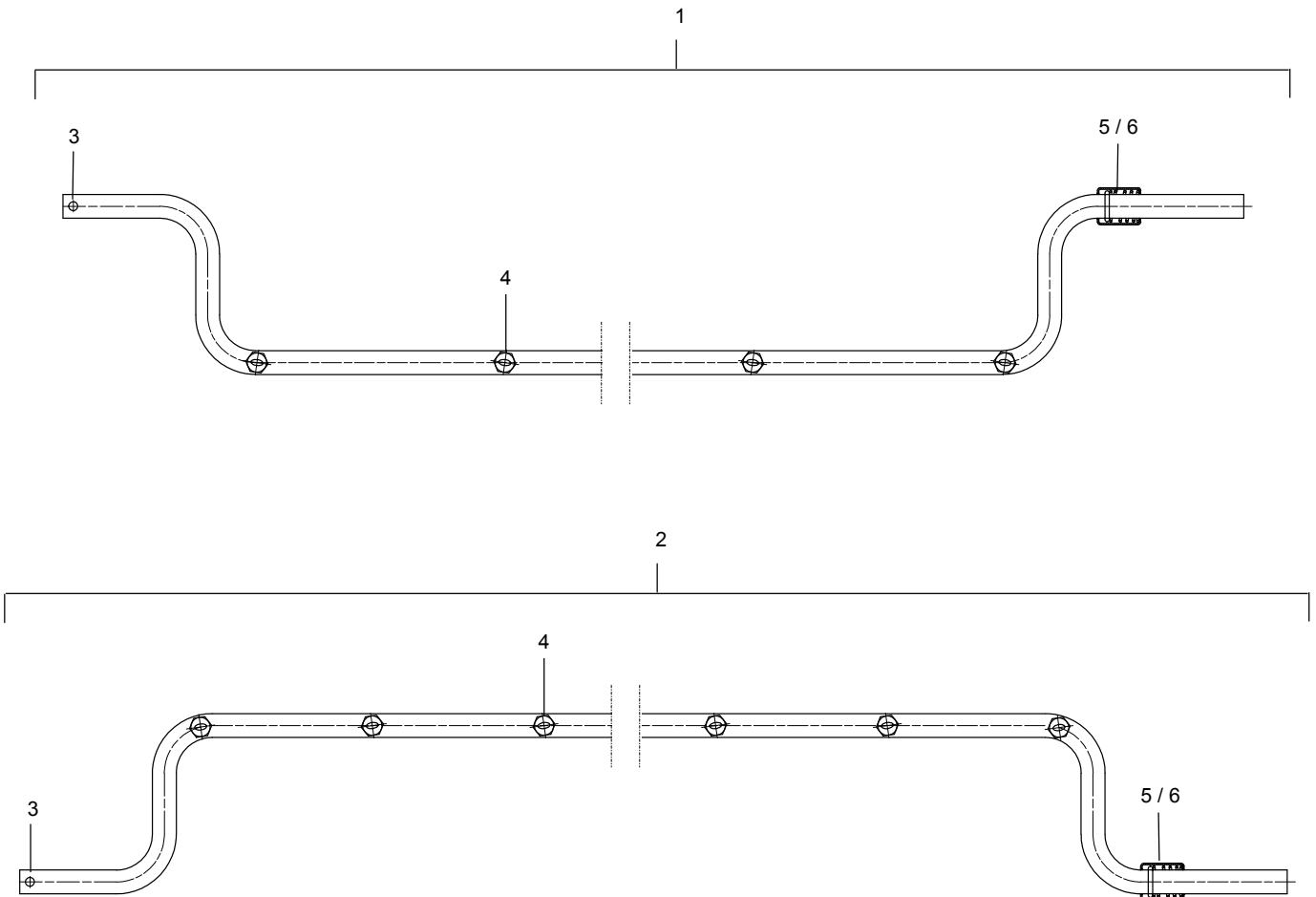

POS	IDENT. NR. IDENT. NO.	BEZEICHNUNG	DESIGNATION	DESIGNATION
1	9551060-01	SPÜLARM FNSP KPL. OBEN L-R B-US 281	UPPER FINAL RINSE ARM CPL. L-R B-US 281	BRAS DE LAVAGE SUP. CPL. G-D B-US 281
	9551060-02	SPÜLARM FNSP KPL. OBEN R-L B-US 281	UPPER FINAL RINSE ARM CPL. R-L B-US 281	BRAS DE LAVAGE SUP. CPL. D-G B-US 281
2	9543788-01	SPÜLARM FNSP KPL. UNTEN L-R B-US 281 / B-US 282/283	LOWER FINAL RINSE ARM CPL. L-R B-US 281 / B-US 282/283	BRAS DE LAVAGE INF. CPL. G-D B-US 281 / B-US 282/283
	9543788-02	SPÜLARM FNSP KPL. UNTEN R-L B-US 281 / B-US 282/283	LOWER FINAL RINSE ARM CPL. R-L B-US 281 / B-US 282/283	BRAS DE LAVAGE INF. CPL. D-G B-US 281 / B-US 282/283
	3	9500279	DRUCKFEDER VD 208	RESSORT VD 208
	4	8103312	FEDERBUCHSE	BOITIER DU RESSORT
* (5) W (10)	5	0472032	DÜSE GRÖSSE 0,8	GICLEUR TAILLE 0,8
	6	0360215	BOLZENSCHWEISSSTIFT Ø6X16	BOULON DE SOUDAGE Ø6X16

Installed in the upper and lower Final Rinse and Aux. Rinse Arm Adapters.

Detail X

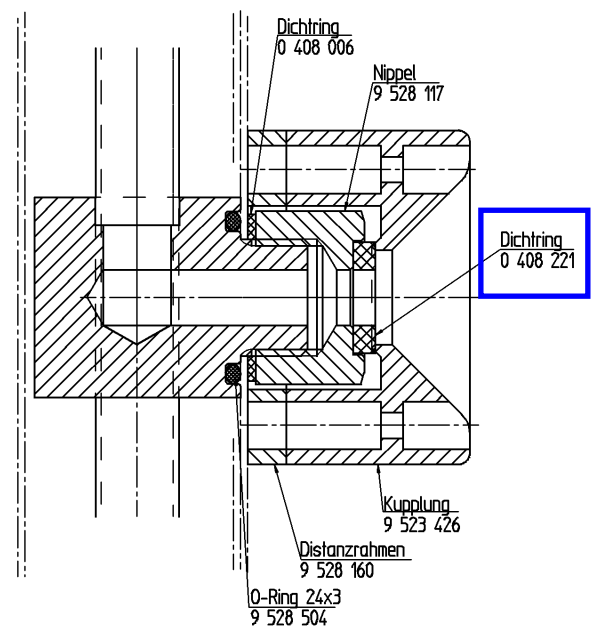
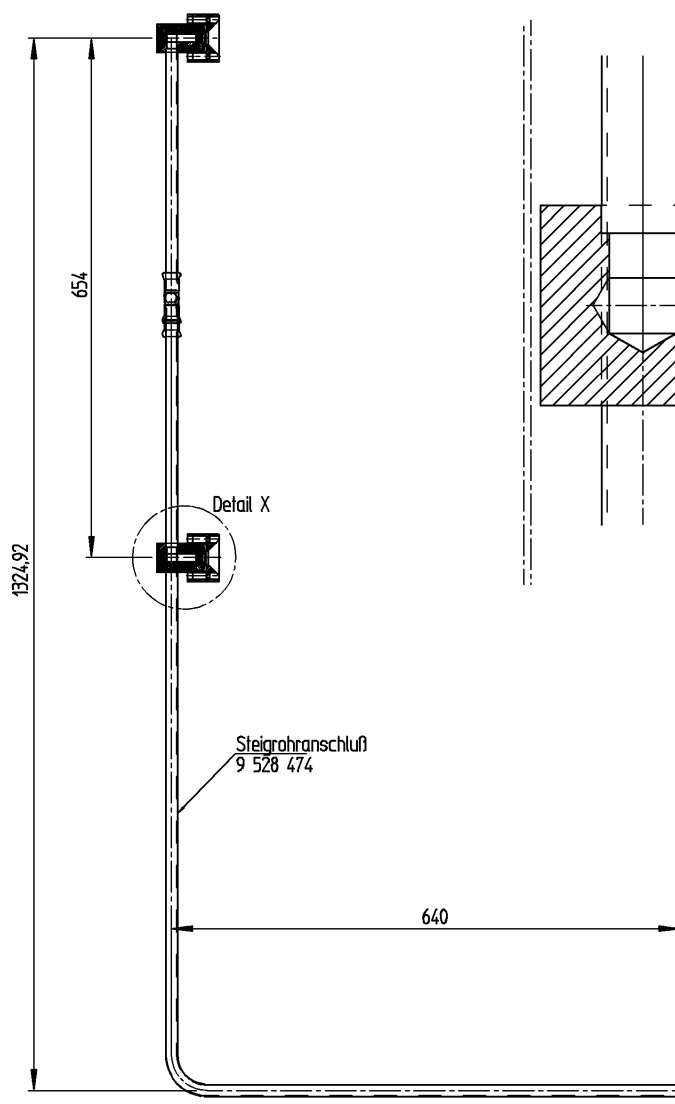
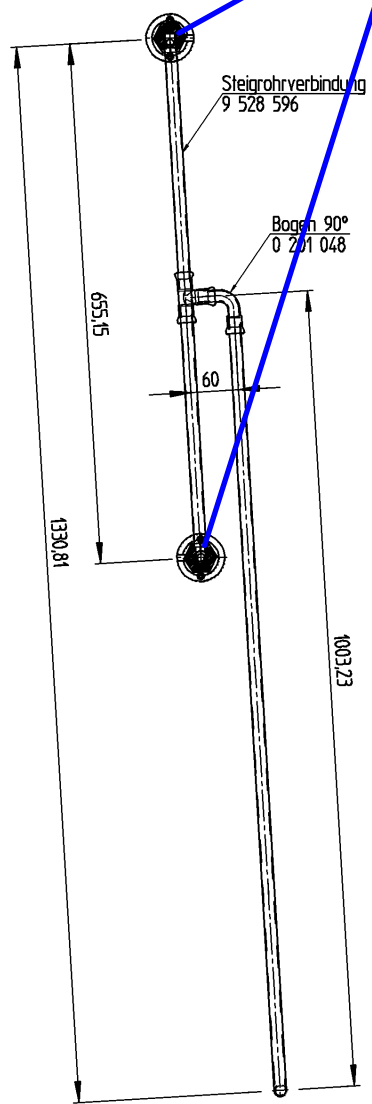
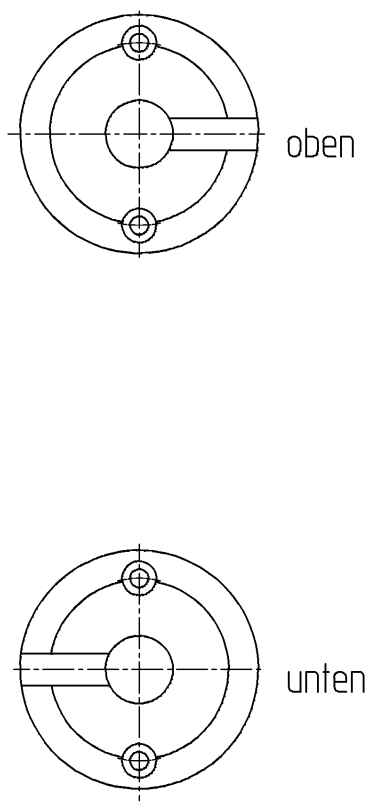

B	Bogen einzeln angezogen	05.07.2001	hs	06.07.2001	hs						
A	Anordnung Kupplung + Maße geä.	22.02.2001	bra	28.02.2001	bra						
Ind.	Änderung / Revision:	gez. Datum:	gez. Name:	gepr. Datum:	gepr. Name:	Ind.	Änderung / Revision:	gez. Datum:	gez. Name:	gepr. Datum:	gepr. Name:
m	NC-Nr.:	051101p48.059		Kunde / Client:							
MEIKO	Abmessung / Dimension:	1,4301		Auftrag / Order-No.:						9528489 02	
Maßstab/Scale:	Stückzahl:	Benennung / Description:				Zeichnung Nr. / Drawing-No.:					
1:7	Number of pieces:	STEIGLEITUNG				BACX3-K 33 002 3 B					
Gezeichnet/Drawn:	Datum / Date:	FNSP KOMPLETT R-L				Ersatz für:					
06.12.2000	hs					Ersetzt durch:					
Geprüft/Checked:	Datum / Date:										
07.12.2000	hs										

05.02 FRISCHWASSERNACHSPÜLUNG – SPÜLARM (B-US282)



05.02 FRESH WATER FINAL RINSE –RINSE ARMS (B-US282)

05.02 RINCAGE FINAL A L'EAU CLAIRE – BRAS DE LAVAGE (B-US282)

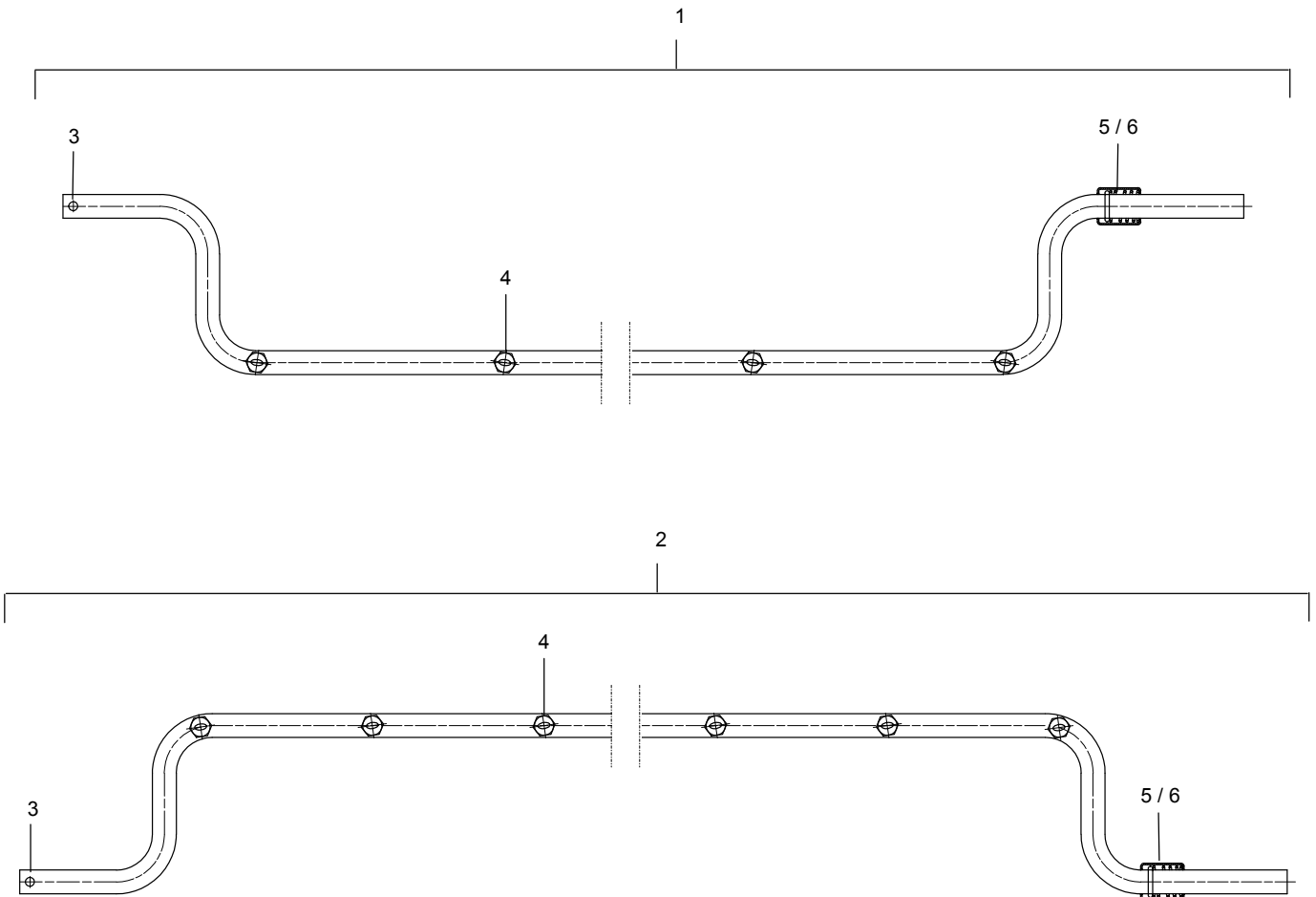

POS	IDENT. NR. IDENT. NO.	BEZEICHNUNG	DESIGNATION	DESIGNATION
1	9551061-01	SPÜLARM FNSP KPL. OBEN L-R B-US 282/283	UPPER FINAL RINSE ARM CPL. L-R B-US 282/283	BRAS DE LAVAGE SUP. CPL. G-D B-US 282/283
	9551061-02	SPÜLARM FNSP KPL. OBEN R-L B-US 282/283	UPPER FINAL RINSE ARM CPL. R-L WIDTH 5	BRAS DE LAVAGE SUP. CPL. D-G B-US 282/283
2	9543788-01	SPÜLARM FNSP KPL. UNTEN L-R B-US 281 / B-US 282/283	LOWER FINAL RINSE ARM CPL. L-R B-US 281 / B-US 282/283	BRAS DE LAVAGE INF. CPL. G-D B-US 281 / B-US 282/283
	9543788-02	SPÜLARM FNSP KPL. UNTEN R-L B-US 281 / B-US 282/283	LOWER FINAL RINSE ARM CPL. R-L B-US 281 / B-US 282/283	BRAS DE LAVAGE INF. CPL. D-G B-US 281 / B-US 282/283
	3	9500279	DRUCKFEDER VD 208	RESSORT VD 208
	4	8103312	FEDERBUCHSE	BOITIER DU RESSORT
* (5) W (10)	5	0472034	DÜSE GRÖSSE 1,2	GICLEUR TAILLE 1,2
	6	0360215	BOLZENSCHWEISSSTIFT Ø6X16	BOULON DE SOUDAGE Ø6X16

06.01 CSS-SYSTEM - PUMPE 0,73 KW - 197-292/340-504V 60HZ



06.01 CSS SYSTEM - PUMP 0,73 KW - 197-292/340-504V 60HZ

06.01 CSS-SYSTEME - POMPE 0,73 KW - 197-292/340-504V 60HZ

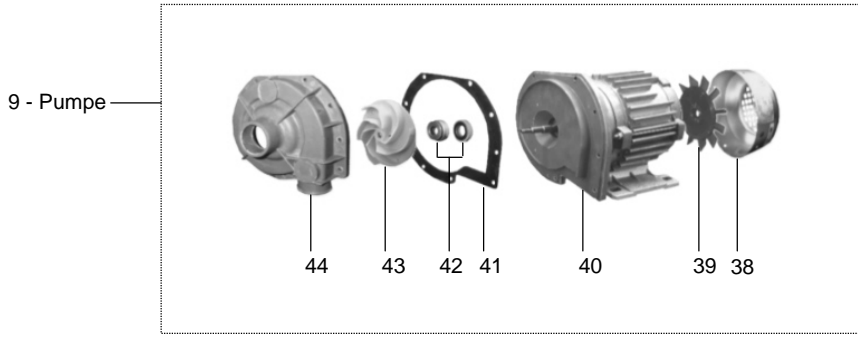
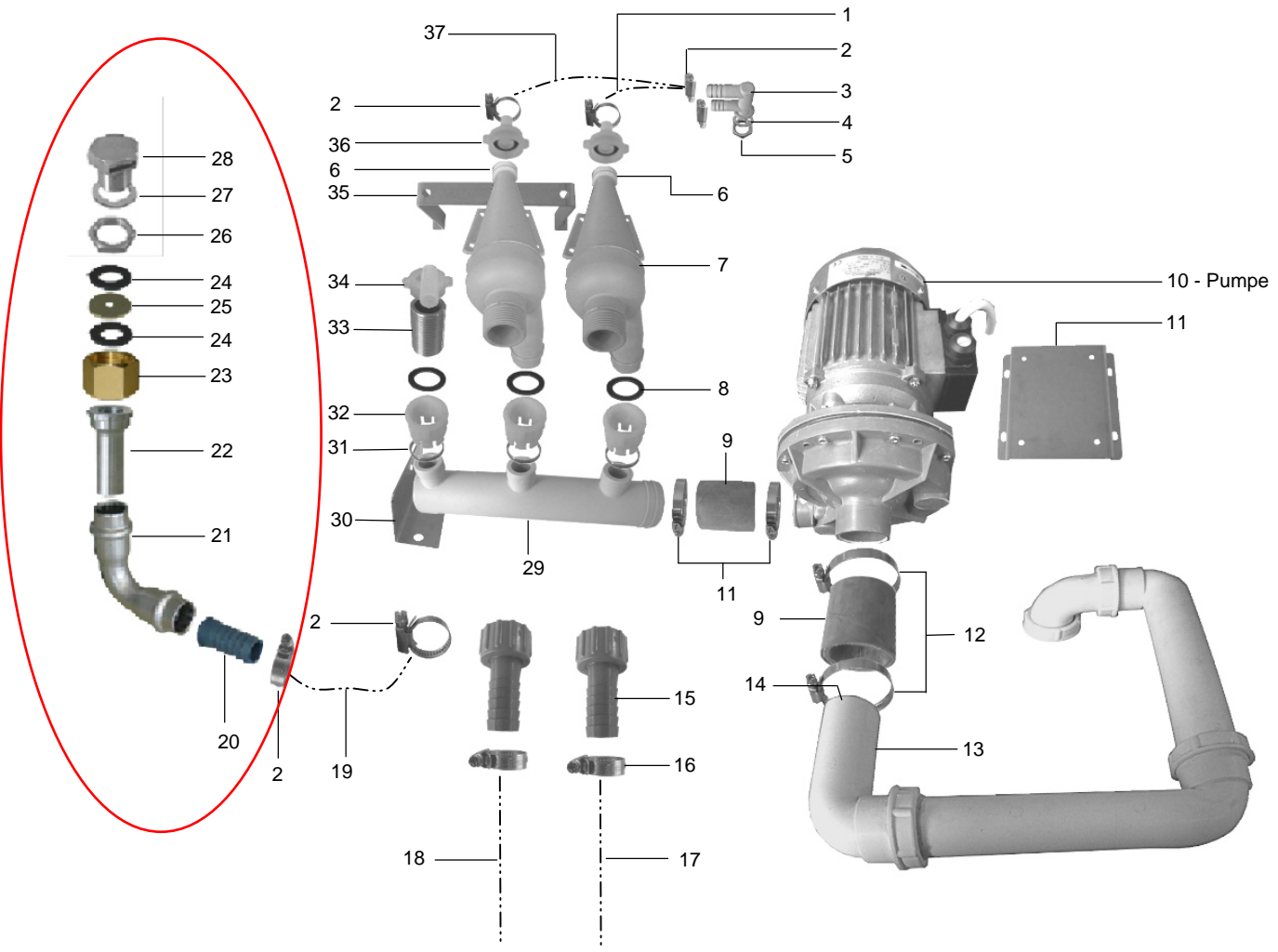

06.01 CSS-SYSTEM - PUMPE 0,73 KW - 197-292/340-504V 60HZ**06.01 CSS SYSTEM - PUMP 0,73 KW - 197-292/340-504V 60HZ****06.01 CSS-SYSTEME - POMPE 0,73 KW - 197-292/340-504V 60HZ**

POS	IDENT. NR. IDENT. NO.	BEZEICHNUNG	DESIGNATION	DESIGNATION	
	1	9505250	SCHLAUCH	HOSE	TUYAU
	2	0233037	SCHLAUCHKLEMME	HOSE WIRE CLAMP	COLLIER DE SERRAGE
	3	0620343	SCHLAUCHANSCHLUSS	HOSE CONNECTION	CONNEXION DE TUYAU
	4	0408238	DICHTUNG	PACKING	JOINT
	5	8660239	MUTTER	NUT	ECROU
	6	0340010	SCHEIBE	DISK	DISQUE
W (1) V	7	9504629	ZYKLONGEHÄUSE	CYCLONE HOUSING	CORPS CYCLONE
W (5) V	8	0408225	DICHTUNG	PACKING	JOINT
W (5)	9	8100538	SCHLAUCH	HOSE	TUYAU
W (1)	10	PUMPE	SIEHE ELEKTROSCHALTPLAN	SEE ELECTRIC DIAGRAM	VOIR SCHEMA ELECTRIQUE
	11	9504015	KONSOLE	CONSOLE	CONSOLE
W(10)	12	0233046	SCHLAUCHKLEMME	HOSE WIRE CLAMP	COLLIER DE SERRAGE
	13	9505185	ANSAUGSTUTZEN L-R	SUCTION PORT L-R	MANCHON D' ASPIRATION G-D
		9505440	ANSAUGSTUTZEN R-L	SUCTION PORT R-L	MANCHON D' ASPIRATION D-G
	14	8000542	VERSTÄRKUNGSRING	REINFORCING RING	BAGUE DE RENFORT
	15	0621028	ÜBERGANGSSTÜCK	CONNECTOR	PIECE DE RACCORDEMENT
	16	0233045	SCHLAUCHKLEMME	HOSE WIRE CLAMP	COLLIER DE SERRAGE
W (5)	17	9505257	SCHLAUCH L-R	HOSE L-R	TUYAU G-D
W (5)	18	9505432	SCHLAUCH R-L	HOSE R-L	TUYAU D-G
	19	9608600	SCHLAUCH	HOSE	TUYAU
	20	8208294	SCHLAUCHNIPPEL	HOSE NIPPLE	RACCORD DU TUYAU
	21	0201045	BOGEN	CURVE	COURBE
	22	8101471	EINLEGETEIL	INSERT	PIECE D'INSERTION
	23	0212020	ÜBERWURFMUTTER	SWIVEL NUT	ECROU-RACCORD
	24	0408225	DICHTUNG	PACKING	JOINT
	25	9536160	DROSSELSCHEIBE	THROTTLE DISK	DISQUE D'ENTRANGLEMENT
	26	8660044	MUTTER	NUT	ECROU
	27	0408226	DICHTUNG	PACKING	JOINT
	28	9504014	FLACHSTRAHLDÜSE	NOZZLE	GICLEUR
	29	0620473	VERTEILERROHR	DISTRIBUTING PIPE	TUYAU DISTRIBUTEUR
	30	9505267	HALTERUNG	SUPPORT	SUPPORT
	31	8302895	HALTERING	SUPPORT RING	BAGUE DE SUPPORT
	32	0113129	ANSCHLUSSTÜCK	CONNECTION PIECE	PIECE DE CONNEXION
	33	8258349	GEWINDENIPPEL	NIPPLE	NIPPLE
	34	9505201	ANSCHLUSWINKEL	CONNECTION ANGLE	ANGLE DE CONNEXION
	35	9505278	HALTEBÜGEL	SUPPORT	SUPPORT
	36	9505200	ANSCHLUSSTÜCK	CONNECTION PIECE	PIECE DE CONNEXION
W (5)	37	9505252	SCHLAUCH L-R	HOSE L-R	TUYAU G-D
W (5)		9505429	SCHLAUCH R-L	HOSE R-L	TUYAU D-G

06.01 CSS-SYSTEM - PUMPE 0,73 KW - 197-292/340-504V 60HZ

06.01 CSS SYSTEM - PUMP 0,73 KW - 197-292/340-504V 60HZ

06.01 CSS-SYSTEME - POMPE 0,73 KW - 197-292/340-504V 60HZ



POS	IDENT. NR. IDENT. NO.	BEZEICHNUNG	DESIGNATION	DESIGNATION	
	38	9518714	LÜFTERHAUBE	FAN COWL	CAPOTAGE DE VENTILATEUR
	39	0501098	VENTILATORFLÜGEL	FAN WHEEL	ROUE VENTILATEUR
	40	0501108	PUMPENDECKEL	PUMP LID	COUVERCLE DE POMPE
W (5) V	41	0501094	DICHTUNG	PACKING	JOINT
W (5) V	42	0501095	GLEITRINGDICHTUNG	SLIDING SEAL	JOINT AXIAL
W (1)	43	9514646	PUMPENLAUFRAD	PUMP WHEEL	ROUE DE POMPE
	44	0501091	PUMPENGEHÄUSE	PUMP HOUSING	CORPS DE POMPE

06.01 CSS-SYSTEM - PUMPE 0,73 KW - 197-292/340-504V 60HZ



06.01 CSS SYSTEM - PUMP 0,73 KW - 197-292/340-504V 60HZ

06.01 CSS-SYSTEME - POMPE 0,73 KW - 197-292/340-504V 60HZ

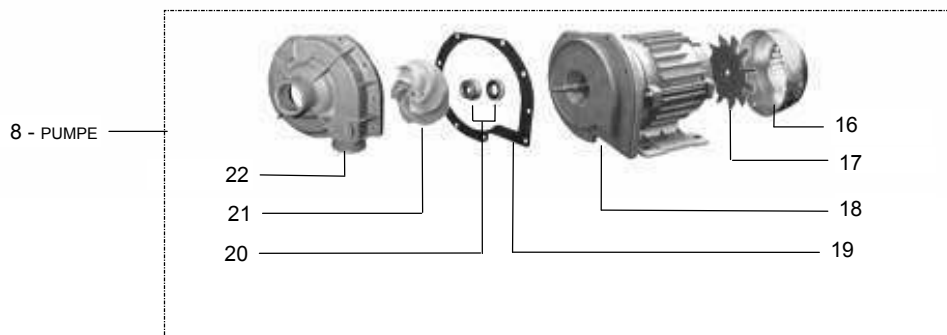
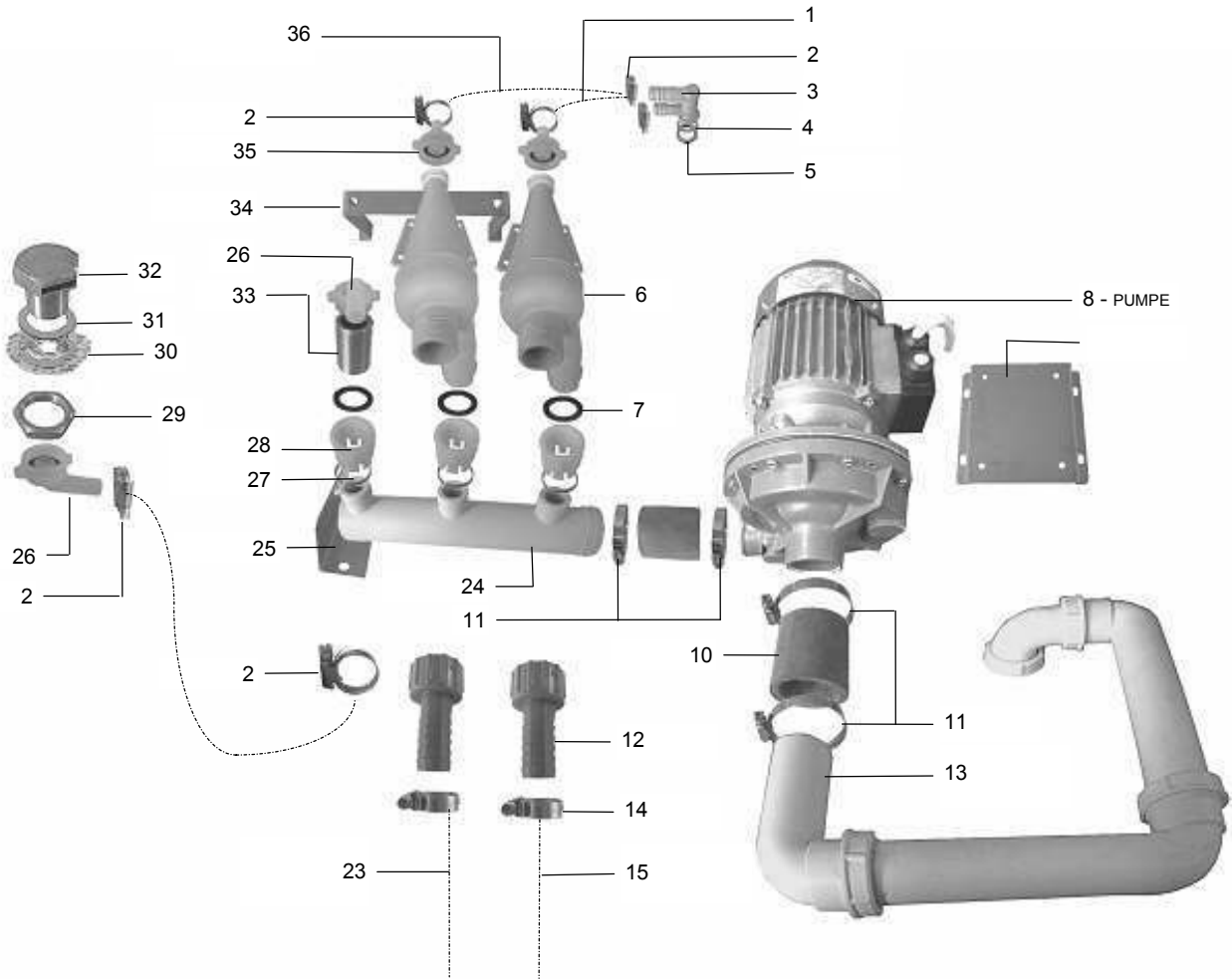

06.01 CSS-SYSTEM - PUMPE 0,73 KW - 197-292/340-504V 60HZ



06.01 CSS SYSTEM - PUMP 0,73 KW - 197-292/340-504V 60HZ

06.01 CSS-SYSTEME - POMPE 0,73 KW - 197-292/340-504V 60HZ

POS	IDENT. NR. IDENT. NO.	BEZEICHNUNG	DESIGNATION	DESIGNATION	
	1	9505250	SCHLAUCH	HOSE	TUYAU
	2	0233037	SCHLAUCHKLEMME	HOSE WIRE CLAMP	COLLIER DE SERRAGE
	3	0620343	SCHLAUCHANSCHLUSS	HOSE CONNECTION	CONNEXION DE TUYAU
	4	0408238	DICHTUNG	PACKING	JOINT
	5	0620162	MUTTER	NUT	ECROU
W (1) V	6	9504629	ZYKLONGEHÄUSE	CYCLONE HOUSING	CORPS CYCLONE
W (5) V	7	0408225	DICHTUNG	PACKING	JOINT
W (1)	8	PUMPE SIEHE ELEKTROSCHALTPLAN	PUMP SEE ELECTRIC WIRING DIAGRAM	POMPE VOIR SCHEMA ELECTRIQUE	
	9	9504015	KONSOLE	CONSOLE	CONSOLE
W (5)	10	8100538	SCHLAUCH	HOSE	TUYAU
W(10)	11	0233046	SCHLAUCHKLEMME	HOSE WIRE CLAMP	COLLIER DE SERRAGE
	12	0621028	ÜBERGANGSSTÜCK	CONNECTOR	PIECE DE RACCORDEMENT
	13	9505185	ANSAUGSTUTZEN L-R	SUCTION PORT L-R	MANCHON D'ASPIRATION G-D
		9505440	ANSAUGSTUTZEN R-L	SUCTION PORT R-L	MANCHON D'ASPIRATION D-G
	14	0233045	SCHLAUCHKLEMME	HOSE WIRE CLAMP	COLLIER DE SERRAGE
W (5)	15	9505257	SCHLAUCH L-R	HOSE L-R	TUYAU G-D
	16	9518714	LÜFTERHAUBE	FAN COWL	CAPOTAGE DE VENTILATEUR
	17	0501098	VENTILATORFLÜGEL	FAN WHEEL	ROUE VENTILATEUR
	18	0501108	PUMPENDECKEL	PUMP LID	COUVERCLE DE POMPE
W (5) V	19	0501094	DICHTUNG	PACKING	JOINT
W (5) V	20	0501095	GLEITRINGDICHTUNG	SLIDING SEAL	JOINT AXIAL
W (1)	21	9514646	PUMPENLAUFRAD	PUMP WHEEL	ROUE DE POMPE
	22	0501091	PUMPENGEHÄUSE	PUMP HOUSING	CORPS DE POMPE
W (5)	23	9505432	SCHLAUCH R-L	HOSE R-L	TUYAU D-G
	24	0620473	VERTEILERROHR	DISTRIBUTING PIPE	TUYAU DISTRIBUTEUR
	25	9505267	HALTERUNG	SUPPORT	SUPPORT
	26	9505201	ANSCHLUSWINKEL	CONNECTION ANGLE	ANGLE DE CONNEXION
	27	8302895	HALTERING	SUPPORT RING	BAGUE DE SUPPORT
	28	0113129	ANSCHLUSSTÜCK	CONNECTION PIECE	PIECE DE CONNEXION
	29	8660044	MUTTER	NUT	ECROU
	30	9536160	DROSSELSCHEIBE	THROTTLE DISK	DISQUE D'ENTRANGLEMENT
	31	0408226	DICHTUNG	PACKING	JOINT
	32	9504014	FLACHSTRAHLDÜSE	NOZZLE	GICLEUR
	33	8258349	GEWINDENIPPEL	NIPPLE	NIPPLE
	34	9505278	HALTEBÜGEL	SUPPORT	SUPPORT
	35	9505200	ANSCHLUSSTÜCK	CONNECTION PIECE	PIECE DE CONNEXION
W (5)	36	9505252	SCHLAUCH L-R	HOSE L-R	TUYAU G-D
W (5)		9505429	SCHLAUCH R-L	HOSE R-L	TUYAU D-G

06.02 CSS-SYSTEM - SPÜLARM



06.02 CSS-SYSTEM - RINSE ARM

06.02 CSS SYSTEME - BRAS DE RINCAGE

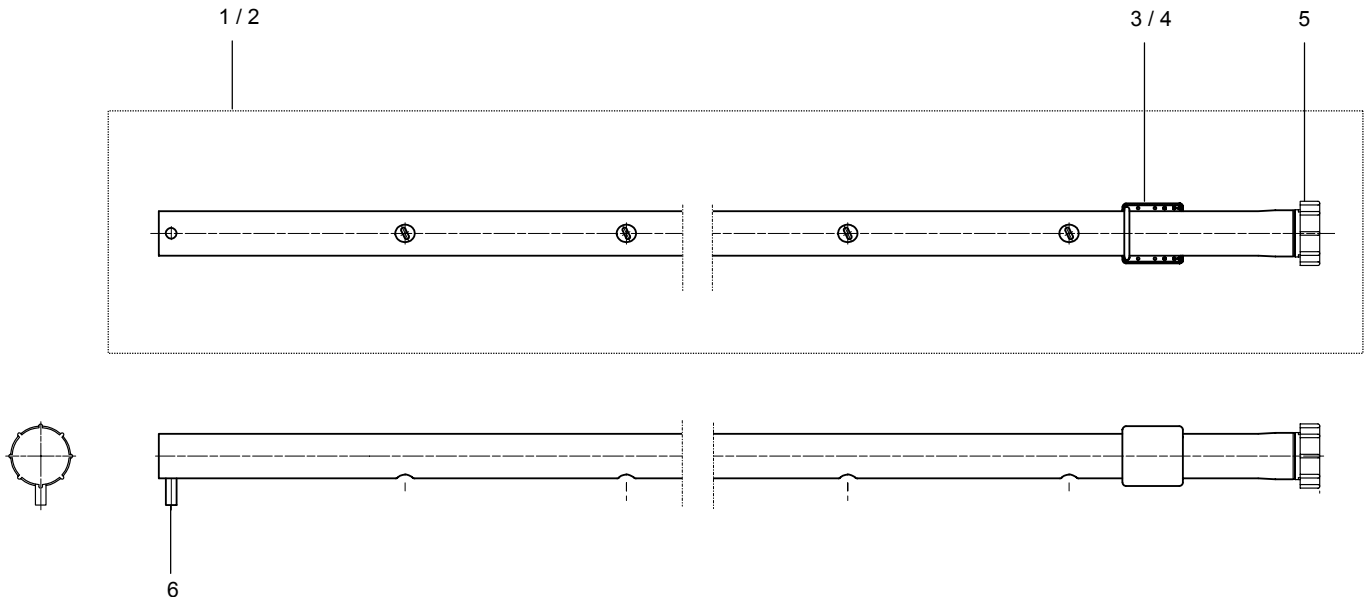

POS	IDENT. NR. IDENT. NO.	BEZEICHNUNG	DESIGNATION	DESIGNATION
1	9533052	SPÜLARM OBEN CSS KPL.	UPPER RINSE ARM CSS CPL.	BRAS DE RINCAGE SUP. CSS CPL.
	9533053	SPÜLARM UNTEN CSS KPL.	LOWER RINSE ARM CSS CPL.	BRAS DE RINCAGE INF. CSS CPL.
2	9500281	DRUCKFEDER VD232F	COMPRESSION SPRING VD232F	RESORTE A COMPRESSION VD232F
3	8103383	FEDERBUCHSE	SPRING BUSHING	DOUILLE A COMPRESSION
W (5)	4 0620163	VERSCHLUSSKAPPE K163	CLOSING CAP K163	CAPUCHON DE FERMETURE
5	9500284	STIFT Ø6X15	SPLINT Ø6X15	CROU A BAJONET Ø6X15

06.03 CSS-SYSTEM - SPÜLARM



06.03 CSS-SYSTEM - RINSE ARM

06.03 CSS SYSTEME - BRAS DE RINCAGE

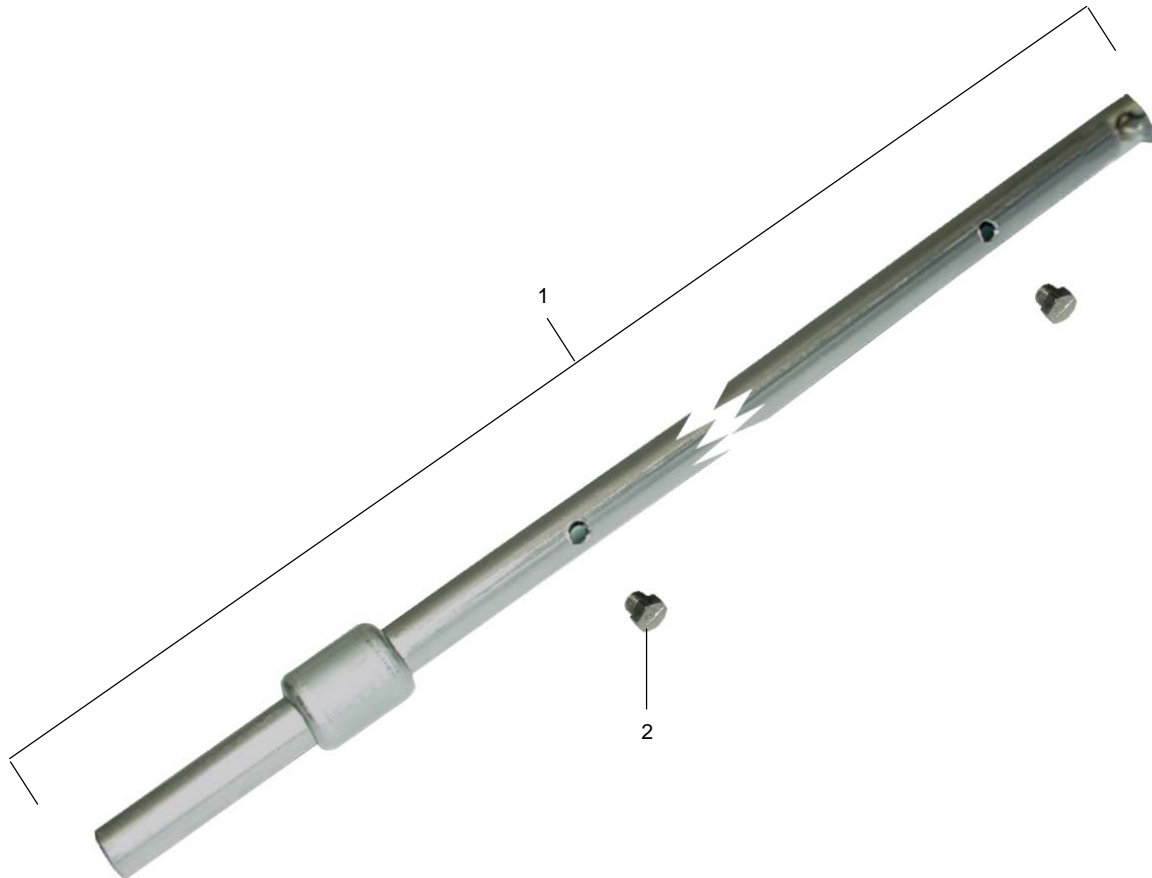

POS	IDENT. NR. IDENT. NO.	BEZEICHNUNG	DESIGNATION	DESIGNATION
-----	--------------------------	-------------	-------------	-------------

1	9533056	SPÜLARM F. UMGEHUNGSWASSER	RINSE ARM	BRAS DE RINCAGE
---	---------	-------------------------------	-----------	-----------------

* (5) W(10)	2	0472035	DÜSE 2,0 NPT 8020 SS	NOZZLE 2,0 NPT 8020 SS	GICLEUR 2,0 NPT 8020 SS
----------------	---	---------	----------------------	------------------------	-------------------------

06.03 CSS-SYSTEM - SPÜLARM



06.03 CSS-SYSTEM - RINSE ARM

06.03 CSS SYSTEME - BRAS DE RINCAGE

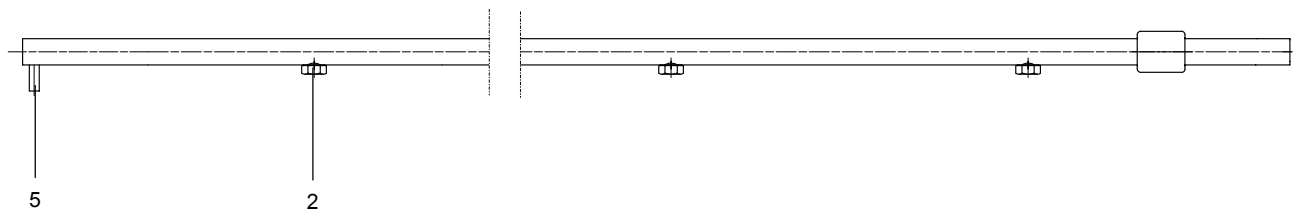
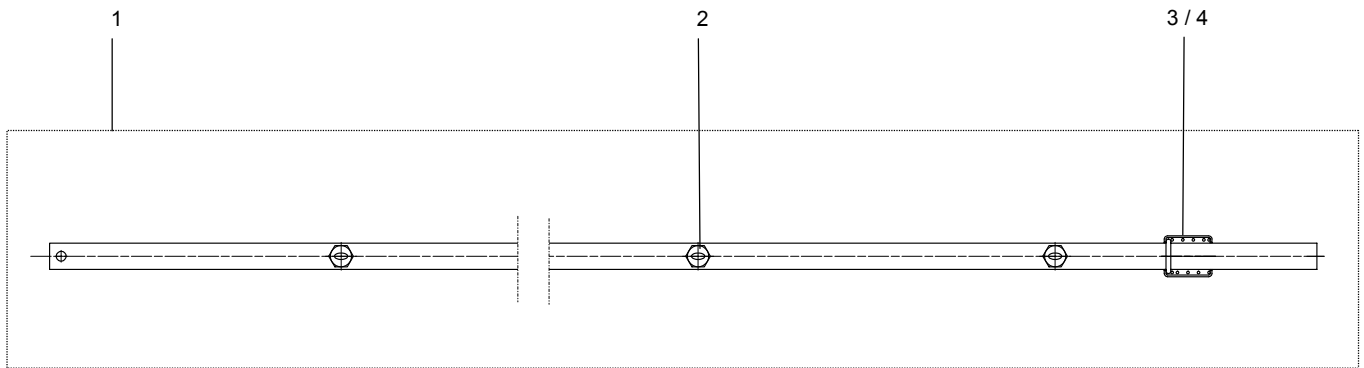

POS	IDENT. NR. IDENT. NO.	BEZEICHNUNG	DESIGNATION	DESIGNATION	
1	9533056	SPÜLARM F. UMGEHUNGSWASSER	RINSE ARM	BRAS DE RINCAGE	
* (5) W(10)	2	0472035	DÜSE 2,0 NPT 8020 SS	NOZZLE 2,0 NPT 8020 SS	GICLEUR 2,0 NPT 8020 SS
	3	9500279	DRUCKFEDER VD208	COMPRESSION SPRING VD208	RESORTE A COMPRESSION VD208
	4	8103312	FEDERBUCHSE	SPRING BUSHING	DOUILLE A COMPRESSION
	5	0360215	STIFT Ø6X16	SPLINT Ø6X16	CROU A BAJONET Ø6X16

07.01 CSS PLUS

07.01 CSS PLUS

07.01 CSS PLUS

**HOSE CONNECTION FOR THE
AIR GAP TANK - 90 DEGREE
- PART # 9501740 -**

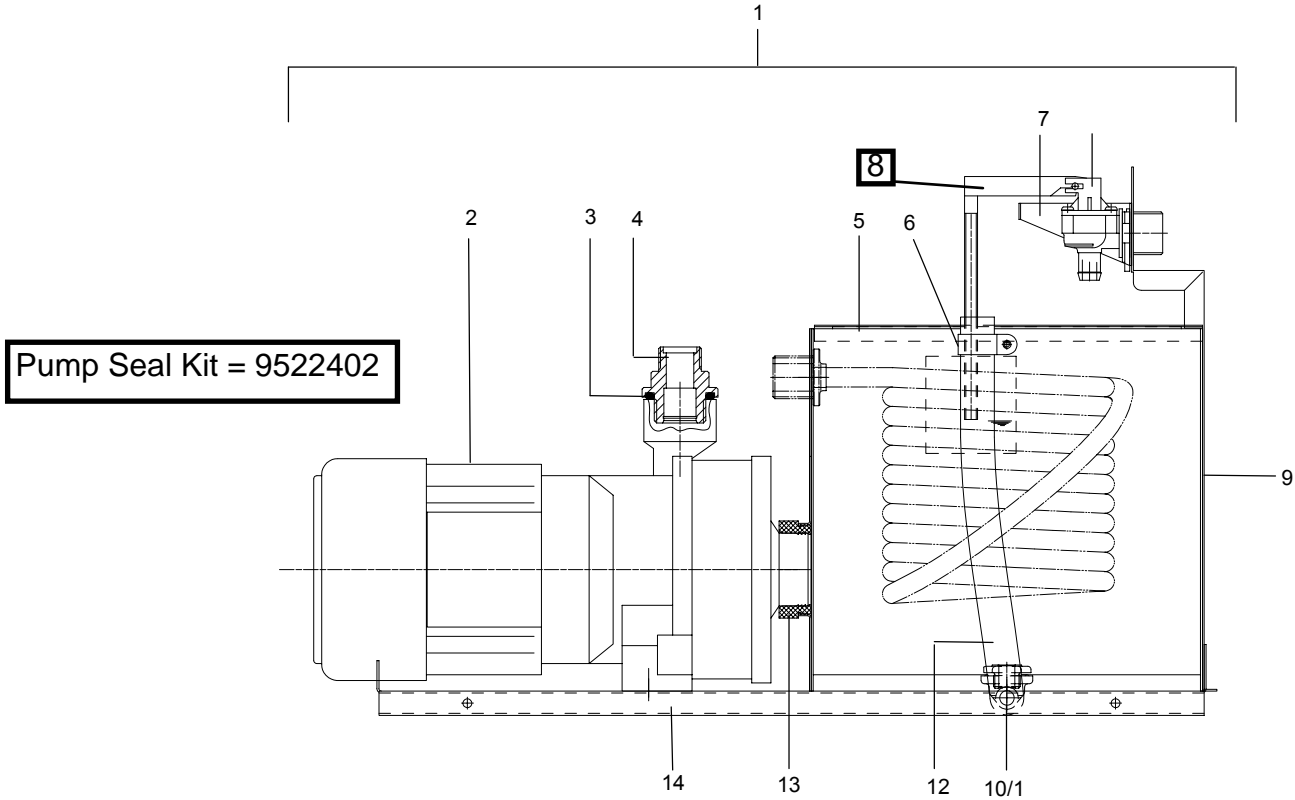

POS	IDENT. NR. IDENT. NO.	BEZEICHUNG	DESIGNATION	DESIGNATION
	1	CSS PLUS KPL.	CSS PLUS CPL.	CSS PLUS CPL.
W (1)	2	PUMPE SIEHE ELEKTROSCHALTPLAN	PUMP SEE ELECTRIC WIRING DIAGRAM	POMPE VOIR SCHEMA ELECTRIQUE
W(10)	3 0408010	DICHTRING GYLON 32X44X1,5 1"	PACKING GYLON 32X44X1,5 1"	JOINT GYLON 32X44X1,5 1"
	4 9501608	ADAPTER D47X47 DRUCKSEITE	ADAPTER D47X47 DELIVERY SIDE OF THE PUMP	ADAPTATEUR 47X47 COTE REFOULEMENT POMPE
	5 9506964	DECKEL	LID	COUVERCLE
	6 0233095	ROHRSCHELLE NR. 3333 CC H 13/16 WEISS	HOSE CLAMP NR 3333 CC H 13/16 WHITE	BRIDE POUR TUYEAU NO. 3333 CC H 13/16 BLANC
	7 9511831	HALTEBLECH	FIXING SHEET	DOLE DE FIXATION
W (5)	8 9529523	SCHWIMMERVERTIL	FLOAT VALVE	VANNE-FLOTTEUR
	9 9506920	BEHÄLTER	CONTAINER	RECIPIENT
W (5)	10 9508052	VERSCHRAUBUNG	SCREWED CONNECTION	VISSAGE
W (5)	11 0401066	O-RING 22X3MM SHORE 75°	O-RING 22X3MM SHORE 75°	ANNEAU TORRIQUE D'ETANCHEITE
	12 9508149	SCHLAUCHANSCHLUSS	HOSE CONNECTOR	RACCORD DE TUYEAU
	13 0650066	MUFFE KD12-K340133 EPDM 60 SHORE SCHWARZ	SLEEVE KD12-K340133 EPDM 60 SHORE BLACK	MANCHON KD12- K340133 EPDM 60 SHORE NOIR
	14 9507216	KONSOLE	CONSOLE	CONSOLE

08.01 MASCHINENSTOLLEN



08.01 FEET OF MACHINE

08.01 PIEDS DE MACHINE

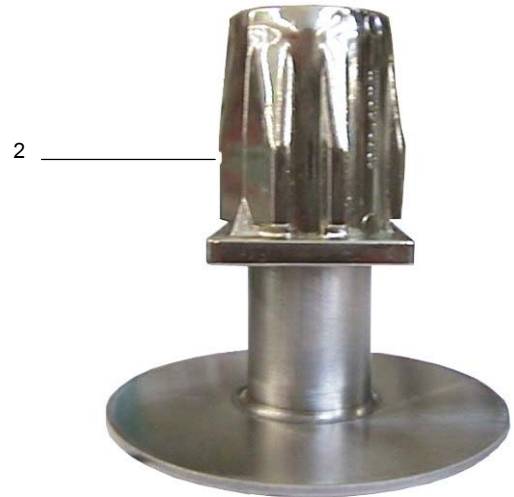
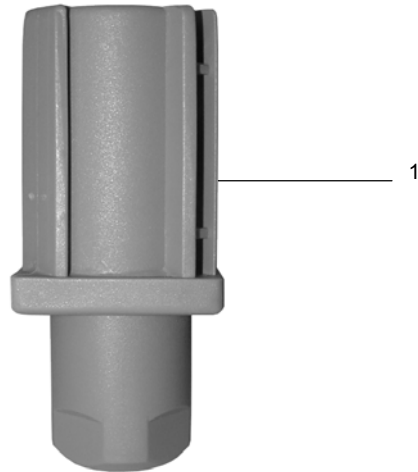

POS	IDENT. NR. IDENT. NO.	BEZEICHNUNG	DESIGNATION	DESIGNATION	
W(20)	1	9533829	TISCHSTOLLEN KPL.	TABLE FEET CPL.	PIEDS DE TABLE CPL.
	2	0460030	STELLFUSS NIRO CAMLOCK 1015-4003-1144	STANDING FEET CAMLOCK 1015-4003-1144	PIEDS NIRO CAMLOCK 1015-4003-1144

09.01 TÜR HÖHE 3



09.01 DOOR HEIGHT 3

09.01 PORTE HAUTEUR 3

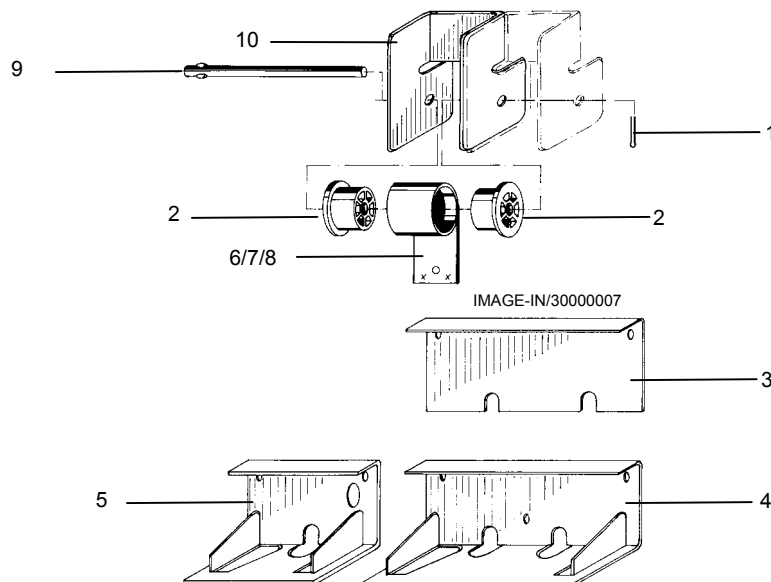

ROLLFEDER / ROLLER SPRING / ROULEAU A TROU (Pos. 7+8+9)	
TÜRBREITE / DOOR WIDTH / LARGEUR DE PORTE	
900 MM	1300 MM
2 X 0431088 / 2X 0431089	4 X 0431090

POS	IDENT. NR. IDENT. NO.	BEZEICHNUNG	DESIGNATION	DESIGNATION	
W (50)	1	0351004	SPLINT DIN 94 2 X 20 MM 1.4301	SPLIT PIN D= 2 X 20	GOUPILLE D= 2 X 20
W (20)	2	0620284	LAGERROLLE 1/2" K280	SUPPORT ROLL 1/2 K 280	ROULEAU SUPPORT 1/2 K 280
	3	8100915	TÜRANSCHLAG 1300ER TÜR 181X54X20	DOOR CATCH, DOOR: 1300 181X54X20	ARRET DE PORTE, PORTE: 1300 181X54X20
	4	8101476	TÜRANSCHLAG 1300 ABLAUF- SCHLIEßUNG 181X78X65	DOOR CATCH, DOOR: 1300 181X78X65	ARRET DE PORTE, PORTE: 1300 181X78X65
	5	8101475	TÜRANSCHLAG 900 M. ABLAUF- SCHLIEßUNG 110X78X65	DOOR CATCH, DOOR: 900 110X78X65	ARRET DE PORTE, PORTE: 900 110X78X65
W (10) V	6	0431088	ROLLFEDER GS 1085 MM 5KG	ROLLER SPRING 5KG	ROULEAU A TROU 5KG
W (10) V	7	0431089	ROLLFEDER GS 1085 MM 7KG	ROLLER SPRING 7KG	ROULEAU A TROU 7KG
W (10) V	8	0431090	ROLLFEDER GS 1085 MM 9KG	ROLLER SPRING 9KG	ROULEAU A TROU 9KG
	9	8100909	LAGERBOLZEN LANG D=8X149	BOLT LONG D=8X149	BOULON D=8X149
	10	8100868	ROLLFEDERHALTERUNG 1.4301 60X60,5X95	SCROLL SPRING SUPPORT 1.4301 60X60,5X95	SUPPORT POUR RESSORT A CROSSE 1.4301 60X60,5X95

09.02 TÜR HÖHE 3



09.02 DOOR HEIGHT 3

09.02 PORTE HAUTEUR 3

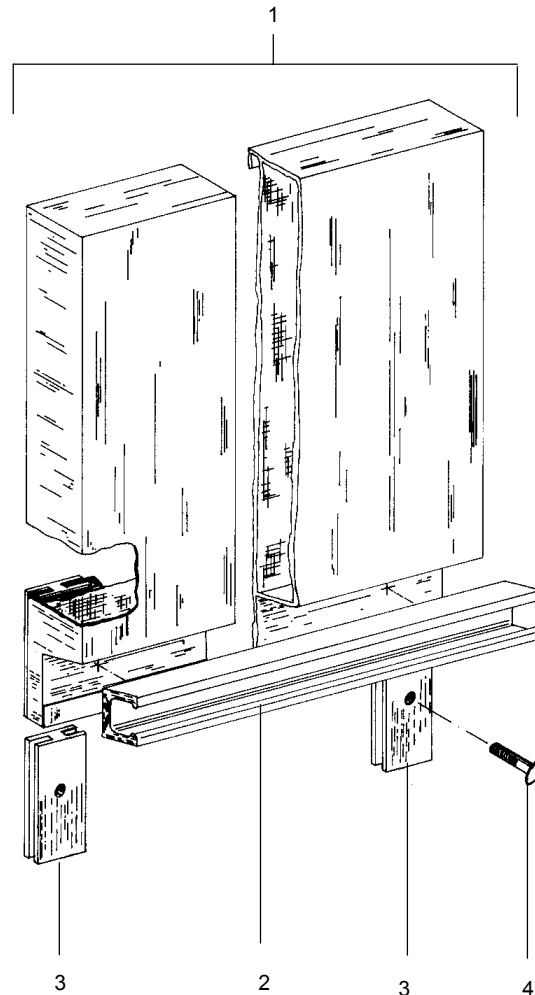

POS	IDENT. NR. IDENT. NO.	BEZEICHUNG	DESIGNATION	DESIGNATION
1	8262522	TÜR KPL. 900MM	DOOR CPL. 900MM	PORTE CPL. 900MM
	8261117	TÜR KPL. 1300MM	DOOR CPL. 1300MM	PORTE CPL. 1300MM
2	8257332	TÜRGRIFFFPROFIL TÜR: 900MM 1.4301M L=886	DOOR HANDLE PROFILE 1.4301 DOOR: 900MM M L=886	PROFILE DE POIGNEE DE PORTE PORTE: 900MM 1.4301M L=886
	8257331	TÜRGRIFFFPROFIL TÜR:1300MM 1.4301M 49X42-1286	DOOR HANDLE PROFILE 1.4301 DOOR:1300MM M 49X42-1286	PROFILE DE POIGNEE DE PORTE PORTE: 1300MM1.4301M 49X42-1286
3	8256304	FÜHRUNGSSCHIENE S SCHW. 30X12,8X1070	GUIDE RAIL 30X12,8X1070	RAIL DE GUIDAGE 30X12,8X1070
4	0325056	FLACHRUNDSCHRAUBE DIN 603 M5X30 MM 1.4301	SAUCER HEAD SCREW DIN 603 M5X30 MM 1.4301	BOULON A TETE BOMBEE DIN 603 M5X30 MM 1.4301

NUT FOR 0325056 CARRAIGE BOLT IS 0337001 M5- NUT NYLON INSERT LOCK NUT

09.03 FLÜGELTÜR 600 / 900 / 1300 - HÖHE 3

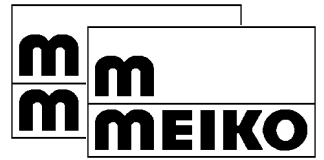

09.03 FOLDING DOOR 600 / 900 / 1300 - HEIGHT 3

09.03 PORTE RABATTABLE 600 / 900 / 1300 - HAUTEUR 3

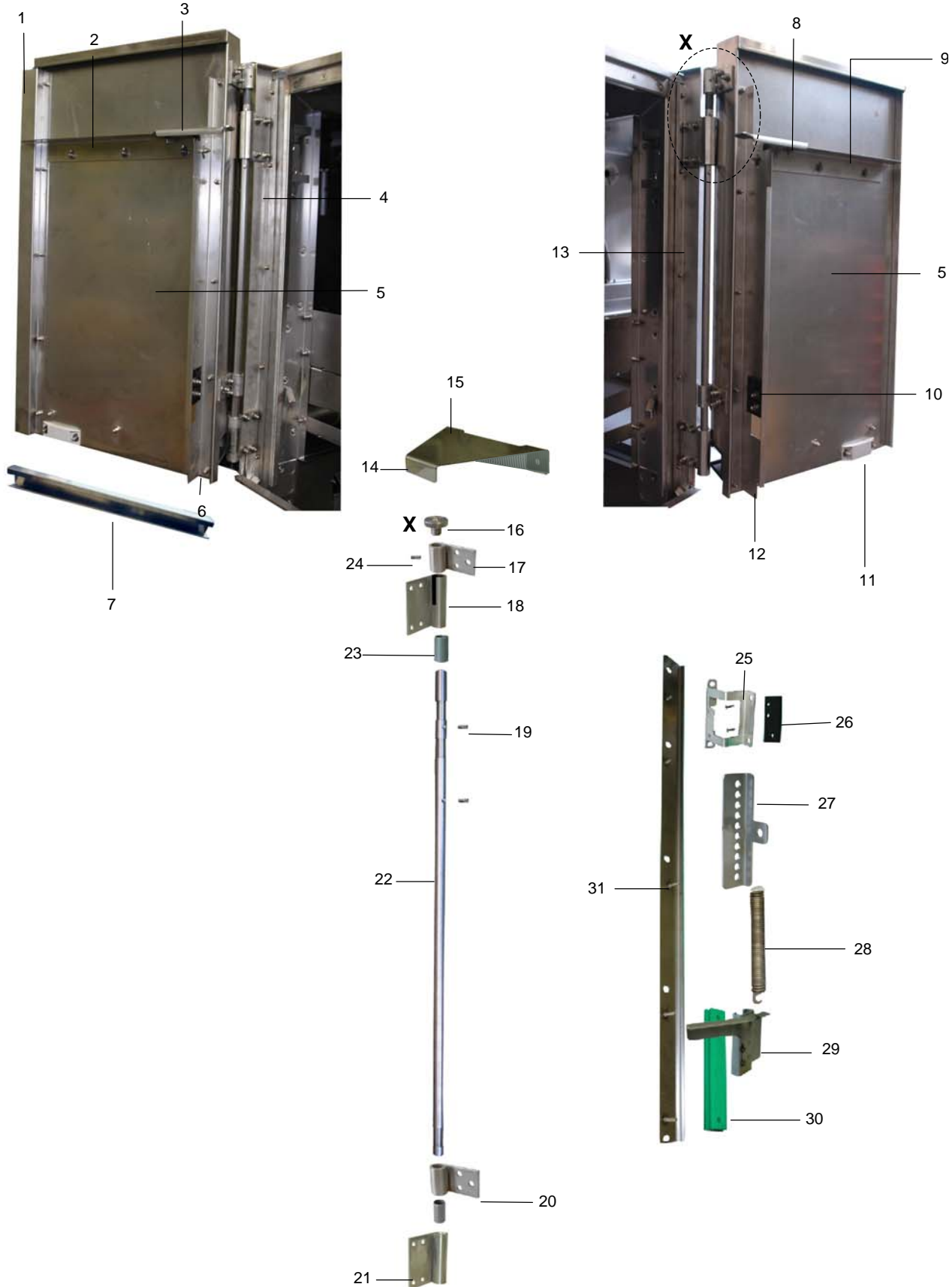

09.03 FLÜGELTÜR 600 / 900 / 1300 - HÖHE 3

09.03 FOLDING DOOR 600 / 900 / 1300 - HEIGHT 3

09.03 PORTE RABATTABLE 600 / 900 / 1300 - HAUTEUR 3



POS	IDENT. NR. IDENT. NO.	BEZEICHNUNG	DESIGNATION	DESIGNATION	
	1	9620796	DICHTPROFIL	SEALING PROFILE	PROFILE D'ETANCHEITE
	2	9625718-03	ABWEISLEISTE (600) L-R	REJECT RAIL (600) L-R	BARRE DE REFOULEMENT (600) G-D
		9625705	ABWEISLEISTE (900) LINKE TÜRSEITE	REJECT RAIL (900) LEFT DOOR END	BARRE DE REFOULEMENT (900) BATTANT DE PORTE GAUCHE
		9625715	ABWEISLEISTE (1300) LINKE TÜRSEITE	REJECT RAIL (1300) LEFT DOOR END	BARRE DE REFOULEMENT (1300) BATTANT DE PORTE GAUCHE
	3	9623851-03	SICHERUNGSBLECH	LOCKING PLATE	TOLE DE SECURITE
	4	9629394-04	WINKEL	ANGLE	ANGLE
	5	9625673	TÜRBLATT (600)	DOOR LEAF (600)	PANNEAU DE PORTE (600)
		9625671	TÜRBLATT (900)	DOOR LEAF (900)	PANNEAU DE PORTE (900)
		9625672	TÜRBLATT (1300)	DOOR LEAF (1300)	PANNEAU DE PORTE (1300)
	6	9620792-03	ABWEISBLECH LINKE TÜRSEITE	DEFLECTION SHEET LEFT DOOR END	TOLE DE DEFLECTION BATTANT DE PORTE GAUCHE
	7	9621048	GRIFFPROFIL (600) CRNI	HANDLE PROFILE (600)	PROFIL DE MANCHE (600)
		9620791	GRIFFPROFIL (900) CRNI	HANDLE PROFILE (900)	PROFIL DE MANCHE (900)
		9620790	GRIFFPROFIL (1300) CRNI	HANDLE PROFILE (1300)	PROFIL DE MANCHE (1300)
	8	9623851-04	SICHERUNGSBLECH	LOCKING PLATE	TOLE DE SECURITE
	9	9625718-04	ABWEISLEISTE (600) R-L	REJECT RAIL (600) R-L	BARRE DE REFOULEMENT (600) D-G
		9625704	ABWEISLEISTE (900) RECHTE TÜRSEITE	REJECT RAIL (900) RIGHT DOOR END	BARRE DE REFOULEMENT (900) BATTANT DE PORTE DROITE
		9625710	ABWEISLEISTE (1300) RECHTE TÜRSEITE	REJECT RAIL (1300) RIGHT DOOR END	BARRE DE REFOULEMENT (1300) BATTANT DE PORTE DROITE
W (2) V	10	9624161	GLEITPROFIL	SLIDING PROFILE	PROFILE DE GLISSIERE
	11	0140200	MAGNET	MAGNET	AIMANT
		0620420	HALTERUNG	FIXING DEVICE	FIXATION
	12	9620792-04	ABWEISBLECH RECHTE TÜRSEITE	DEFLECTION SHEET RIGHT DOOR END	TOLE DE DEFLECTION BATTANT DE PORTE DROITE
	13	9629394-03	WINKEL	ANGLE	ANGLE
	14	9631283	ANSCHLAG TEIL 2	CATCH PART 2	ARRET PARTIE 2
	15	9631280	ANSCHLAG TEIL 1	CATCH PART 1	ARRET PARTIE 1
	16	0310010	RÄNDELSCHRAUBE	KNURLED SCREW	VIS MOLLETEE
	17	9624911	SCHARNIERBAND	HINGE	CHARNIERE A BANDE
	18	9624795	SCHARNIER RECHTE TÜRSEITE	HINGE RIGHT DOOR END	CHARNIERE BATTANT DE PORTE DROITE
		9624443	SCHARNIER LINKE TÜRSEITE	HINGE LEFT DOOR END	CHARNIERE BATTANT DE PORTE GAUCHE
W (2) V	19	9631455	SCHAFTSCHRAUBE M6X12	SET SCREW M6X12	VIS SANS TETE M6X12
	20	9625711	SCHARNIERBAND	HINGE	CHARNIERE A BANDE
	21	9624798	SCHARNIER	HINGE	CHARNIERE

09.03 FLÜGELTÜR 600 / 900 / 1300 - HÖHE 3

09.03 FOLDING DOOR 600 / 900 / 1300 - HEIGHT 3

09.03 PORTE RABATTABLE 600 / 900 / 1300 - HAUTEUR 3



POS	IDENT. NR. IDENT. NO.	BEZEICHNUNG	DESIGNATION	DESIGNATION
	22 9625778	ACHSE	AXLE	AXE LONGITUDINAL
W (3) V	23 9625907	GLEITLAGER	SLIDING BEARING	PALIER LISSE
	24 9549622	ZYLINDERKERBSTIFT	GROOVED CYLINDRICAL PIN	GOUPILLE CYLINDRIQUE A ENTAILLE
	25 9623871-03	HALTEBLECH LINKE TÜRSEITE	FIXING PANEL LEFT DOOR END	TOLE DE SUPPORT BATTANT DE PORTE GAUCHE
	9623871-04	HALTEBLECH RECHTE TÜRSEITE	FIXING PANEL RIGHT DOOR END	TOLE DE SUPPORT BATTANT DE PORTE DROITE
W (2) V	26 9623240	PLATTE	PLATE	PLAQUE
	27 9626252	FEDERSPANNWINKEL	TENSION SPRING BRACKET	SUPPORT RESSORT A TENSION
W (2) V	28 9614265	ZUGFEDER	TENSION SPRING	RESSORT DE TENSIONS
	29 9624678-03	SCHIEBEBLECH LINKE TÜRSEITE	SLIDING SHEET LEFT DOOR END	TOLE COULISSANTE BATTANT DE PORTE GAUCHE
	9624678-04	SCHIEBEBLECH RECHTE TÜRSEITE	SLIDING SHEET RIGHT DOOR END	TOLE COULISSANTE BATTANT DE PORTE DROITE
W (2) V	30 9622841	FÜHRUNGSSCHIENE	GUIDE RAIL	GLISSIERE DE GUIDAGE
	31 9622929-03	FLANSCHPLATTE	FLANGE PLATE	PLAQUE DE BRIDE
	9622929-04	FLANSCHPLATTE	FLANGE PLATE	PLAQUE DE BRIDE

10.01 SPRITZSCHUTZVORHANG



10.01 CURTAIN

10.01 RIDEAU



POS	IDENT. NR. IDENT. NO.	BEZEICHNUNG	DESIGNATION	DESIGNATION
W (3) V	1	8260258 VORHANG KPL. EINLAUF 3-LAGIG 1.4301 / PVC 860X600	CURTAIN - ENTRANCE THREE-LAYER PVC 860X600	
W (3) V	2	9548585 VORHANG KPL. EINLAUF / TANK 1.4301 / PVC 860X520	CURTAIN - IN FRONT OF PREWASH AND EACH WASH TANK PVC 860X520	
W (3) V		9542156 VORHANG KPL. VOR NACHSPÜLUNG 1.4301 / PVC 860X300	CURTAIN CPL. IN FRONT OF AUXILLIARY RINSE PVC 860X300	
W (3) V		9548587 VORHANG KPL. WÄRMERÜCKGEWINNUNG 1.4301 / PVC 735X520	CURTAIN CPL. BETWEEN FINAL RINSE AND BLOWER DRYER PVC 735X520	
W (3) V		8259315 VORHANG KPL. TT ENDE 1.4301 / PVC 820X600	CURTAIN CPL. EXIT END PVC 820X600	

11.01 ABDECKSIEB - EINLAUF / CSS



11.01 COVERING SIEVE - INFEED / CSS

11.01 TAMIS DE RECOUVREMENT - ENTREE / CSS



POS	IDENT. NR. IDENT. NO.	BEZEICHNUNG	DESIGNATION	DESIGNATION
1	9533695	ABDECKSIEB KPL. 654X770X30, 1.4301	COVERING SIEVE CPL. 654X770X30, 1.4301	TAMIS DE RECOUVREMENT CPL. 654X770X30, 1.4301
	9533718	ABDECKSIEB KPL. 358X740X30, 1.4301	COVERING SIEVE CPL. 358X740X30, 1.4301	TAMIS DE RECOUVREMENT CPL. 358X740X30, 1.4301
	9528405	ABDECKSIEB KPL. 504X770X30, 1.4301	COVERING SIEVE CPL. 504X770X30, 1.4301	TAMIS DE RECOUVREMENT CPL. 504X770X30, 1.4301
	9602661	ABDECKSIEB KPL. 474X770X30, 1.4301	COVERING SIEVE CPL. 474X770X30, 1.4301	TAMIS DE RECOUVREMENT CPL. 474X770X30, 1.4301

11.02 TANKABDECKSIEB



11.02 TANK COVERING SIEVE

11.02 TAMIS DE RECOUVREMENT DE BAC

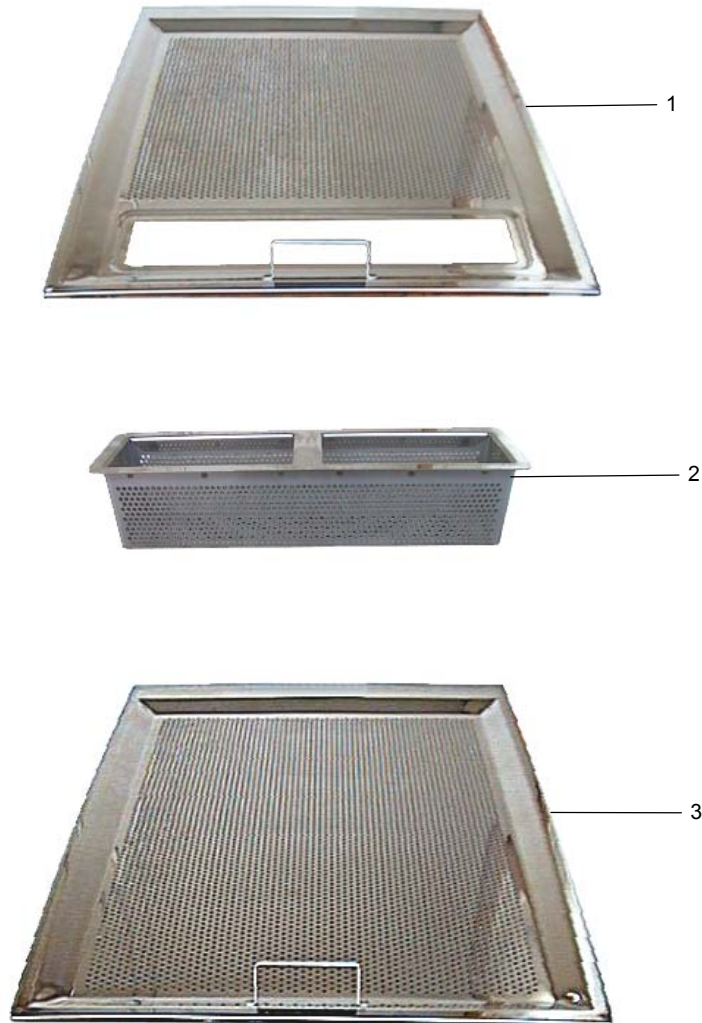

POS	IDENT. NR. IDENT. NO.	BEZEICHNUNG	DESIGNATION	DESIGNATION
1	9528522	ABDECKSIEB KPL. FÜR SIEBKORB 858X546,5X16,25, 1.4301	COVERING SIEVE CPL. FOR SIEVE DRAWER 858X546,5X16,25, 1.4301	TAMIS DE RECOUVREMENT CPL. POUR TAMIS FILTRE 858X546,5X16,25, 1.4301
2	8103193	SIEBKORB 900 TANK	SIEVE DRAWER 900 TANK	TAMIS FILTRE POUR BAC 900
3	9528512	ABDECKSIEB KPL. 858X546,5X16,25, 1.4301	COVERING SIEVE CPL. 858X546,5X16,25, 1.4301	TAMIS DE RECOUVREMENT CPL. 858X546,5X16,25, 1.4301

12.01 ABLAUF

12.01 DRAIN

12.01 VIDANGE

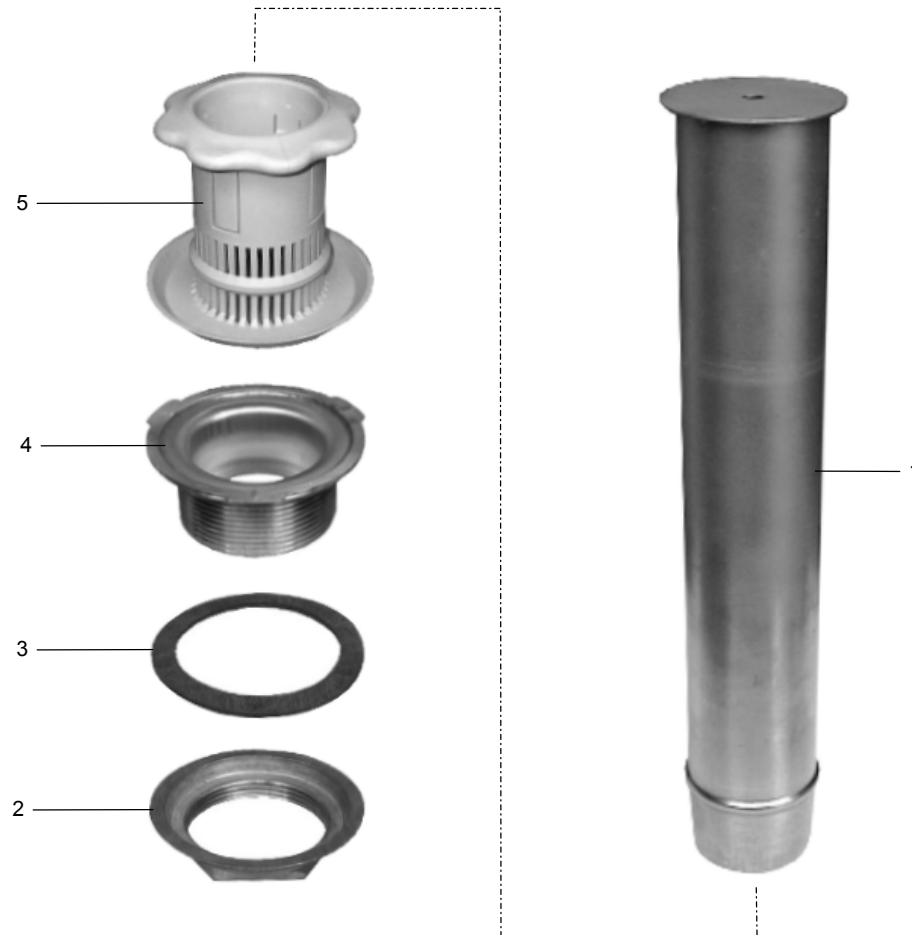

POS	IDENT. NR. IDENT. NO.	BEZEICHNUNG	DESIGNATION	DESIGNATION	
	1	8101478	STANDROHR KOMPL. F. TÜRSCHLIEßUNG Ø50X301,25	DRAIN PLUG Ø50X301,25	BONDE DE TROP PLEIN Ø50X301,25
W (2)	2	0237008	STANDR.VENT.-MUTTER 9942 MS 2"X88	NUT NO. 9942 MS 2"X88	ECROU NO. 9942 MS 2"X88
W (2)	3	0408224	GUMMIDICHTUNG EPDM 78X60X2	RUBBER PACKING 78X60X2	JOINT EN CAOUTCHOUC 78X60X2
W (2)	4	0237100	ABLAUF G2" KOMPLETT 434131240	DRAIN 2" CPL. 434131240	VIDANGE 2" CPL. 434131240
* (2) W (5)	5	0620358	SIEB FUER STANDROHR K363	SIEVE FOR DRAIN PLUG K363	TAMIS POUR TUYAU DE VIDANGE K363

13.01 SCHWIMMERSCHALTER



13.01 FLOAT SWITCH

13.01 INTERRUPTEUR FLOTTANT

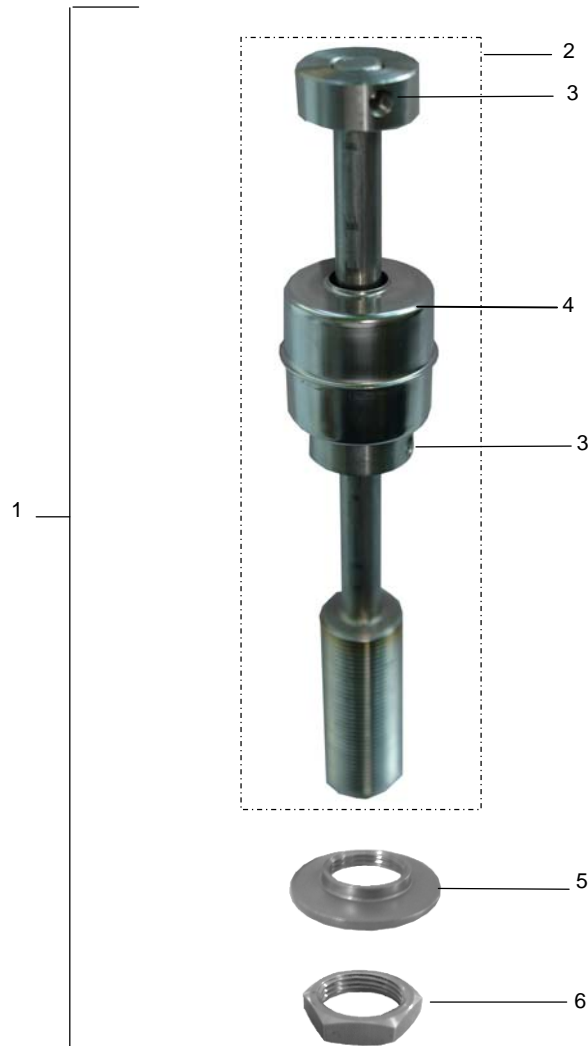

POS	IDENT. NR. IDENT. NO.	BEZEICHUNG	DESIGNATION	DESIGNATION
	4	SCHWIMMERSCHALTER KPL.	FLOAT SWITCH CPL.	FLOTTEUR POUR NIVEAU DE BAC CPL.
W (5)	5	SCHWIMMERSCHALTER TYP 266.022.34	FLOAT SWITCH TYPE 266.022.34	FLOTTEUR POUR NIVEAU DE BAC TYPE 266.022.34
	6	STELLRING	FIXING RING	BAGUE DE FIXATION
	7	SCHWIMMER	FLOAT	FLOTTEUR
W (5)	8	MUTTER 3/4"	NUT 3/4"	ECROU 3/4"
W (5)	9	SKT. MUTTER 3/4"	HEXAGONE SCREW 3/4"	ECROU A 6 PANS 3/4"

Schwimmerschalter kpl.
9 537 398

Schwimmerschalter
Typ 266.022.20
0 130 024

Old Style Float Switch Assy. !
Replaced by P/N 9649896

Blechmutter 3/4"
8 104 009 14301

Mit Sista oder
Teflonband eindichten.

Mutter 3/4" CuZn
8 660 097

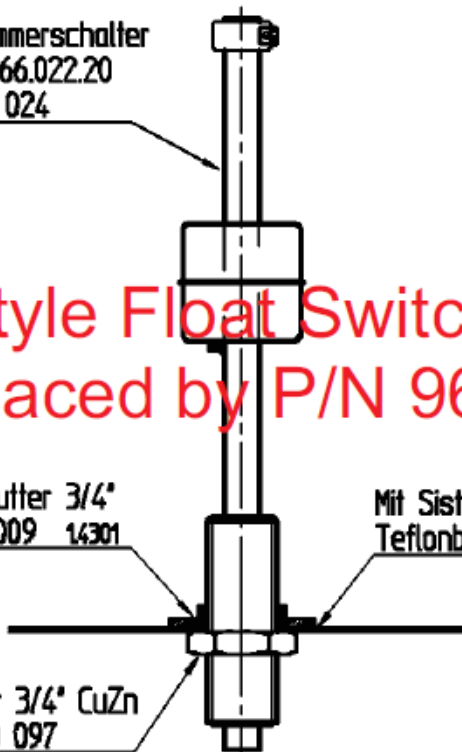

31.01 ZEIGERTHERMOMETER



31.01 DIAL THERMOMETER

31.01 THERMOMETRE A AIGUILLE



POS	IDENT. NR. IDENT. NO.	BEZEICHNUNG	DESIGNATION	DESIGNATION
1	9546260	ZEIGERTHERMOMETER KAPILLARROHRLÄNGE 10FT	DIAL THERMOMETER LENGTH OF CAPILLARY TUBE 10FT	THERMOMETRE A AIGUILLE LONGUEUR DU TUBE CAPILLAIRE 10FT

31.02 ZEIGERTHERMOMETER

31.02 DIAL THERMOMETER

31.02 THERMOMETRE A AIGUILLE



POS	IDENT. NR. IDENT. NO.	BEZEICHNUNG	DESIGNATION	DESIGNATION
1	9640414	ZEIGERTHERMOMETER KAPILLARROHRLÄNGE 25FT	DIAL THERMOMETER LENGTH OF CAPILLARY TUBE 25FT	THERMOMETRE A AIGUILLE LONGUEUR DU TUBE CAPILLAIRE 25FT

14.01 WASSERSPARRECHEN

14.01 WATER SAVING DEVICE

14.01 SYSTEME D'ECONOMIE D'EAU

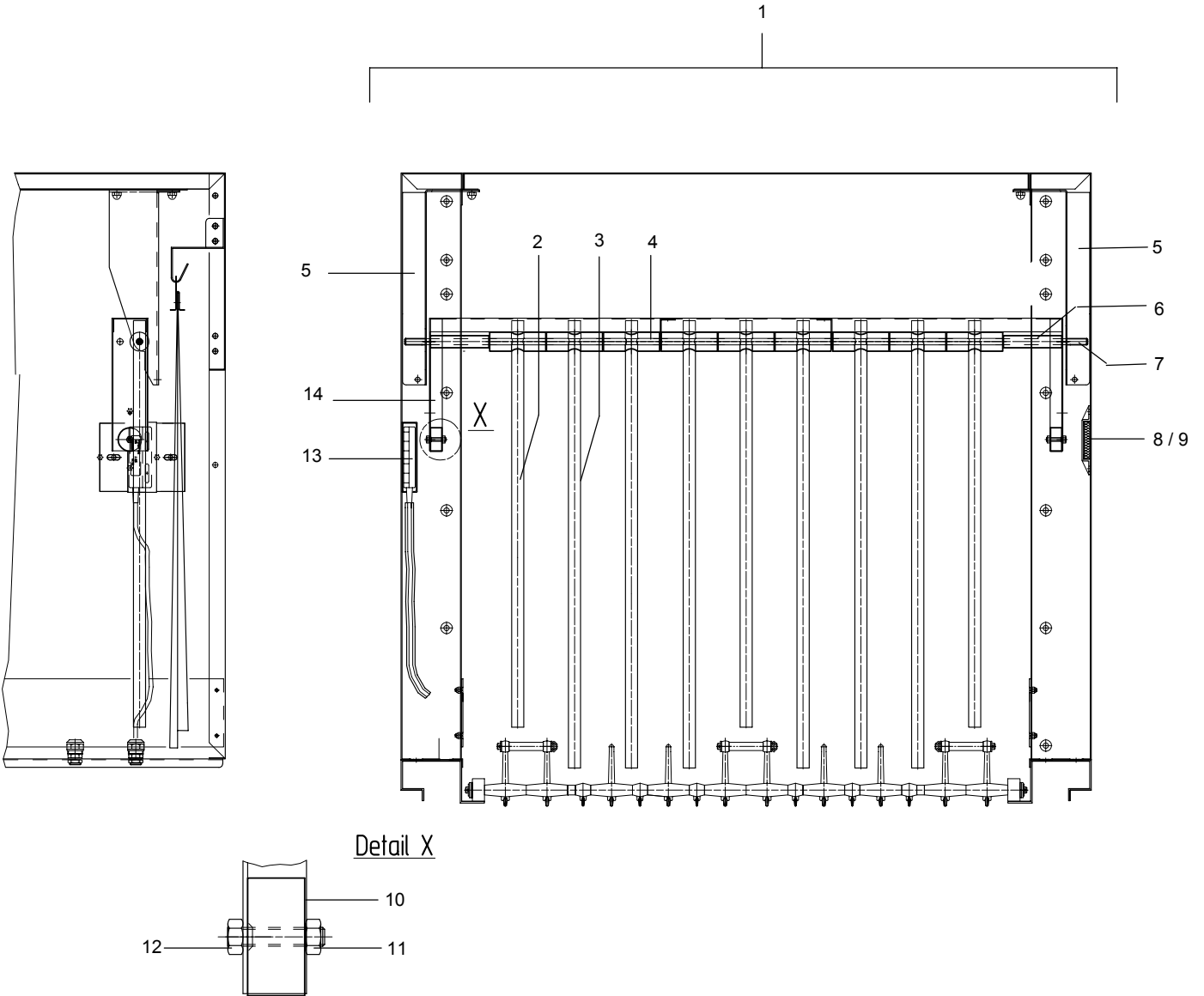

14.01 WASSERSPARRECHEN



14.01 WATER SAVING DEVICE

14.01 SYSTEME D'ECONOMIE D'EAU

POS	IDENT. NR. IDENT. NO.	BEZEICHNUNG	DESIGNATION	DESIGNATION
1	9529418-01	WASSERSPARSCHALTER KPL. L-R	WATER SAVING DEVICE CPL. L-R	SYSTEME D'ECONOMIE D'EAU CPL. G-D
	9529418-02	WASSERSPARSCHALTER KPL. R-L	WATER SAVING DEVICE CPL. R-L	SYSTEME D'ECONOMIE D'EAU CPL. D-G
2	9529402	ROHR Ø16X2 L=536	TUBE Ø16X2 L=536	TUYAU Ø16X2 L=536
3	9529403	ROHR Ø16X2 L=590	TUBE Ø16X2 L=590	TUYAU Ø16X2 L=590
4	8100693	LAGERROHR	TUBE	TUYAU
5	8261829-03	HALTERUNG WASSERSPARSCHALTER	SUPPORT WATER SAVING DEVICE	SUPPORT SYSTEME D'ECONOMIE D'EAU
	8261829-04	HALTERUNG WASSERSPARSCHALTER	SUPPORT WATER SAVING DEVICE	SUPPORT SYSTEME D'ECONOMIE D'EAU
6	9529424	DISTANZSTÜCK PP	INTERMEDIATE PIECE PP	PIECE INTERMEDIAIRE PP
7	9529408	LAGERSTANGE	ROD	BARRE
8	0620420	HALTERUNG FÜR MAGNET	SUPPORT FOR MAGNET	SUPPORT POUR AIMANT
9	0140200	MAGNET BARIUM-FERRIT	MAGNET BARIUM-FERRIT	AIMANT BARIUM-FERRIT
10	0140206	RINGMAGNET HARTFERRIT	RING SHAPED MAGNET HARTFERRIT	AIMANT ANNULAIRE HARTFERRIT
11	0336050	HUTMUTTER M5	CAP NUT M5	ECROU BORGNE M5
12	0302049	SECHSKANTSCHRAUBE M5X20	HEXAGON SCREW M5X20	VIS A 6 PANS M5X20
13	0122050	ENDSCHALTER	FINAL SWITCH	INTERRUPTEUR FINAL
14	9529399	WIPPE KPL.	ROCKER CPL.	BASCULE CPL.

15.01 ENDSCHALTERWIPPE



15.01 FINAL SWITCH DEVICE

15.01 DISPOSITIF DE L'INTERRUPTEUR

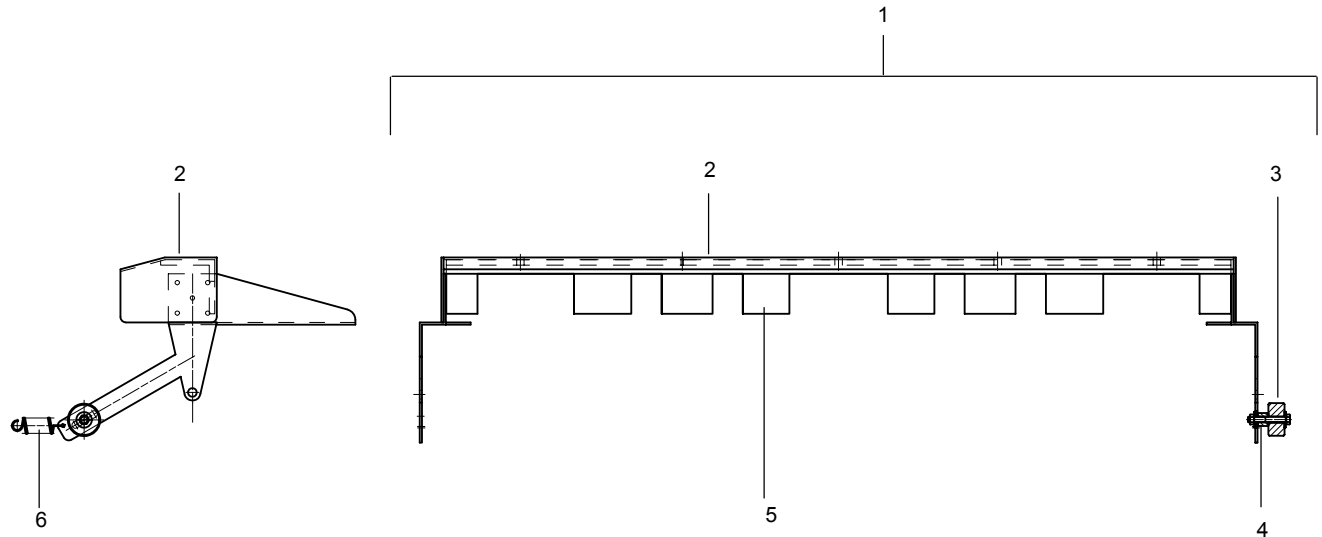

POS	IDENT. NR. IDENT. NO.	BEZEICHNUNG	DESIGNATION	DESIGNATION
1	9531437	ENDSCHALTERWIPPE KPL	FINAL SWITCH DEVICE CPL.	DISPOSITIF DE L'INTERRUPTEUR CPL.
2	9537968	ENDSCHALTERWIPPE	FINAL SWITCH DEVICE	DISPOSITIF DE L'INTERRUPTEUR
3	0140206	RINGMAGNET HARTFERRIT 24/16 D=31X5,3X15 MM	RING SHAPED MAGNET 24/16 D=31X5,3X15 MM	AIMANT ANNULAIRE 24/16 D=31X5,3X15 MM
4	0620231	DISTANZSTUECK K125/10 10 MM	INTERMEDIATE PIECE D= 8,5 X10 LONG K 125=10	PIECE INTERMEDIAIRE D=8,5 X 10 LONG K 125/10
5	9531431	WINKEL FÜR ENDSCHALTERWIPPE WIRD TRANSPORTBAND ANGEPASST	PLASTIC ANGLE FOR FINAL SWITCH DEVICE WILL BE ADJUSTED TO THE CONVEYOR BELT	ANGLE POUR INTERRUPTEUR FINAL SERA ADAPTE AU CONVOYEUR
6	0430002	ZUGFEDER V2A 15 X 42 X 1 MM	TENSION SPRING 15 X 42 X1 4301	RESSORT DE TENSIONS 15 X 42 X , 4301

16.01 TRANSPORTBAND 9529348



16.01 TRANSPORT CONVEYOR

16.01 CONVOYEUR DE TRANSPORT

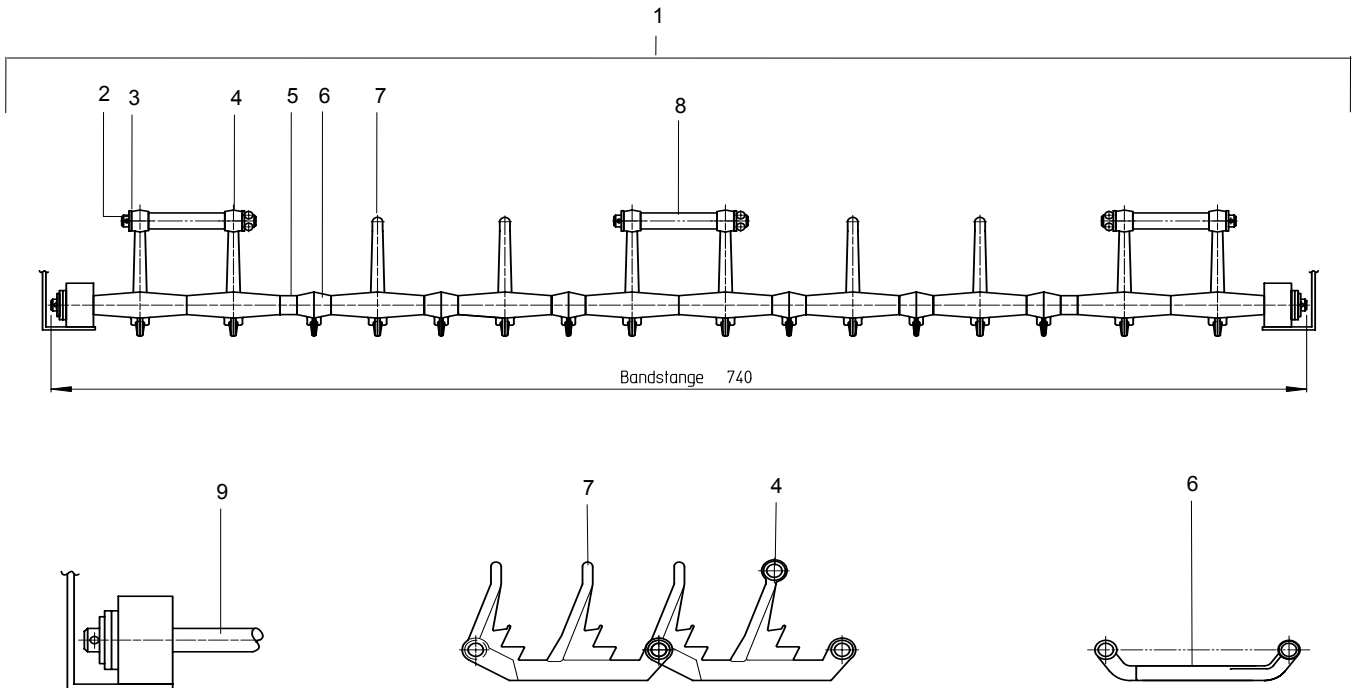

POS	IDENT. NR. IDENT. NO.	BEZEICHNUNG	DESIGNATION	DESIGNATION
	1 9529348	TRANSPORTBAND	TRANSPORT CONVEYOR	BANDE DE TRANSPORT
	2 8155032	BANDSTANGE KURZ Ø8X79	BELT ROD SHORT Ø8X79	AXE DE CONVOYEUR COURT Ø8X79
	3 0340002	U-SCHEIBE DIN 433	WASHER DIN 433	RONDELLE DIN 433
W(100) V	4 90620337	BANDFINGER K273 T108	BELT FINGER K273 T108	DOIGT DE BANDE K273 T108
W(20) V	5 0620231	DISTANZSTUECK K125/10	INTERMEDIATE PIECE K125/10	PIECE INTERMEDIAIRE K125/10
W(100) V	6 0620111	ZWISCHENGLIED K111A T108	INTERMEDIATE MEMBER K111A T108	PIECE INTERMEDIAIRE K111A T108
W(100) V	7 0620223	BANDFINGER K223 T108	BELT FINGER K223 T108	DOIGT DE BANDE K223 T108
W(20) V	8 8150068	DISTANZSTUECK Ø12,5X2X45	INTERMEDIATE PIECE Ø12,5X2X45	PIECE INTERMEDIAIRE Ø12,5X2X45
	9 9529336	BANDSTANGE Ø8X740	BELT ROD Ø8X740	BARRE DE CONVOYEUR Ø8X740

16.03 TRANSPORTBAND, T108



16.03 TRANSPORT BELT, T108

16.03 BANDE DE TRANSPORT, T108

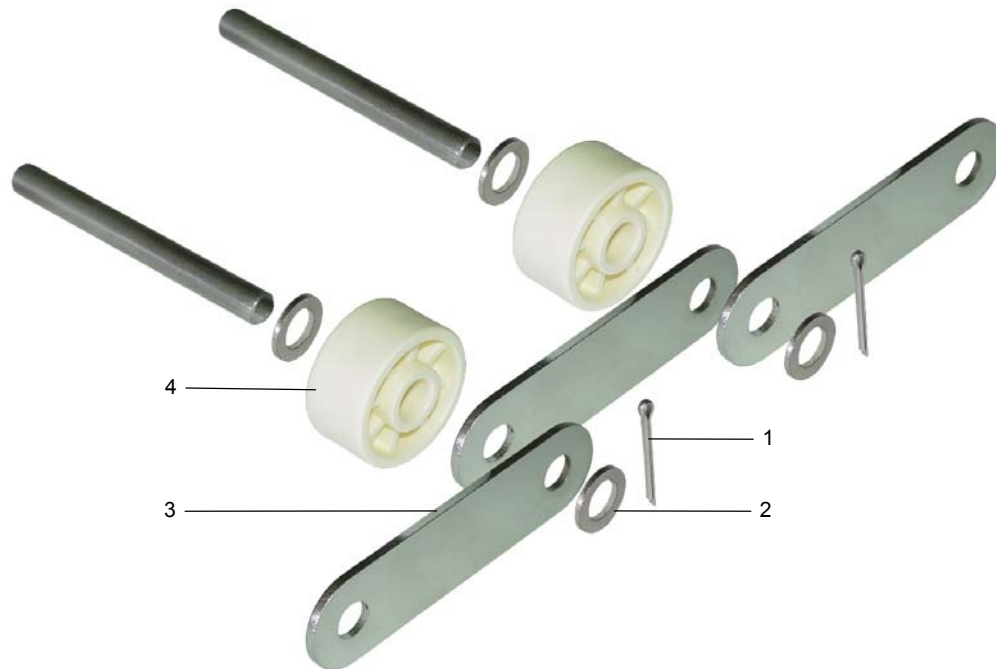

POS	IDENT. NR. IDENT. NO.	BEZEICHNUNG	DESIGNATION	DESIGNATION
W (100) V	1 0351004	SPLINT DIN 94 2X20	SPLIT PIN DIN 94 2X20	GOUPILLE DIN 94 2X20
	2 0340002	U-SCHEIBE DIN 433	WASHER DIN 433	RONDELLE DIN 433
	3 8155002	KETTENLASCHE T108	CHAIN PLATE DIVISION T108	MAILLON DE CHAINE DIVISION T108
W (50) V	4 0620149	LAUFROLLE K149	ROLLER K149	GALET K149

17.01 BANDANTRIEB



17.01 BELT DRIVE

17.01 ENTRAINEMENT DE CONVOYEUR

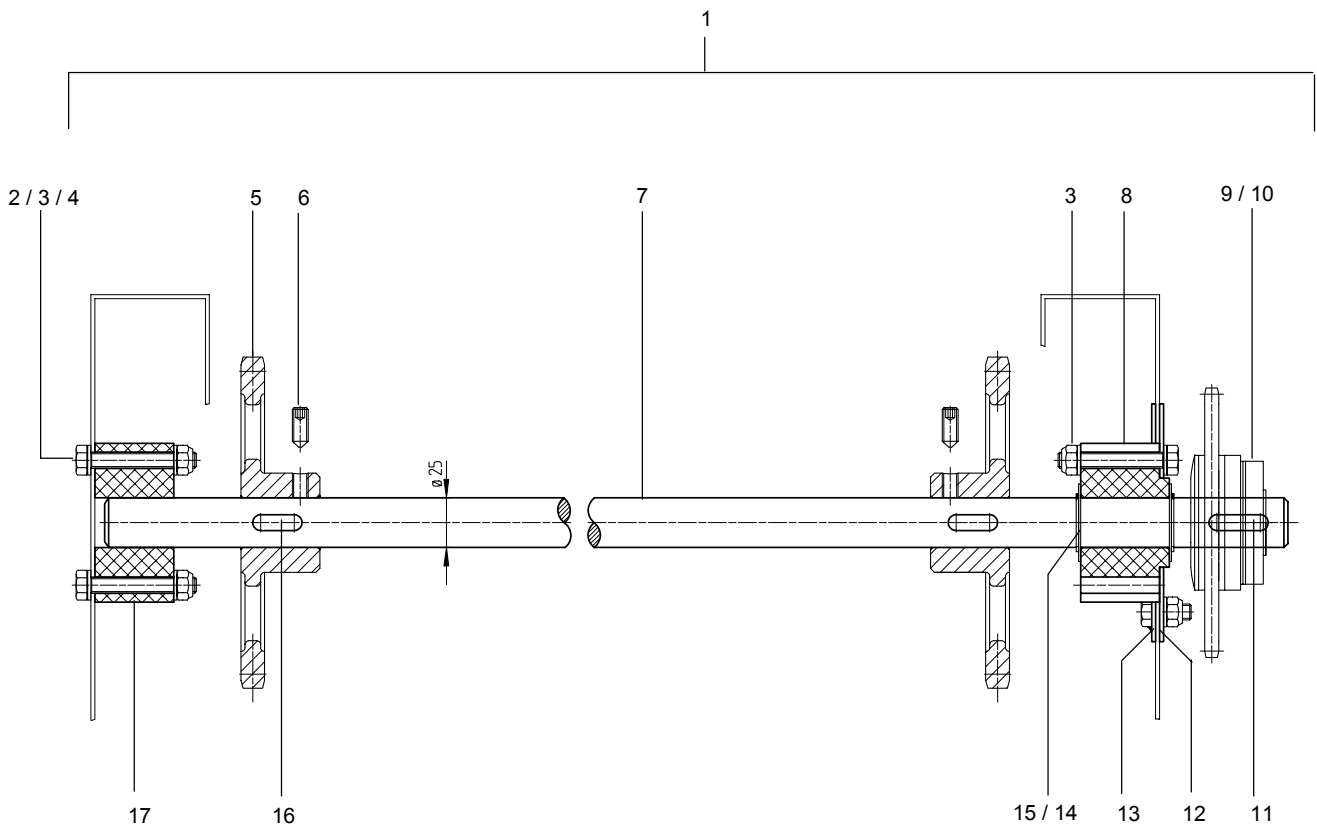

17.01 BANDANTRIEB



17.01 BELT DRIVE

17.01 ENTRAINEMENT DE CONVOYEUR

POS	IDENT. NR. IDENT. NO.	BEZEICHNUNG	DESIGNATION	DESIGNATION	
	1	9529082	ANTRIEBSWELLE KPL	DRIVE SHAFT CPL.	ENTRAINEMENT D'ARBRE CPL
	2	0302015	SKT.-SCHRAUBE M 8X55 A2 DIN 933	HEXAGON SCREW M 8 X 55, DIN 933, 4301	VIS A 6 PANS, M 8X55, DIN 933, 4301
	3	0337005	SKT.-MUTTER M 8 A4 SELBSTSICH. DIN 985	HEXAGON NUT M 8, 4301 DIN 985	ECROU A SIX PANS M8, 4301 DIN 985
	4	0340002	U-SCHEIBE 1.4301 DIN 433 8,4 MM	WASHER 4301 8,4 MM 433	RONDELLE D= 8,4, DIN 433, 4301
W (4)	5	8107030	KETTENRAD MIT NUT T108 Z4 Ø25 PP RD 30	CHAIN WHEEL WITH NUT T108 Z4 Ø25 PP RD 30	ROUE DE CHAINE AVEC RAINURE T108 Z4 Ø25 PP RD 30
	6	0322022	GEWINDESTIFT DIN 916 M8X20 MM 1.4301	SET SCREW DIN 916 M8X20 MM W.INT.HEXAGONAL	VIS SANS TETE DIN 916 M8X20MM A.HEXAGONE INT
	7	8256095	ANTRIEBSWELLE D=25X924 1.4301	DRIVE SHAFT D=25X924	ENTRAINEMENT DE ROUE D=25X924
W (2)	8	8660161	LAGER D=80X44 "S" SCHWARZ	BEARING D=80X44 "S" BLACK AN-42.00.02.4	PALIER D=80X44 "S" NOIR
W (2)	9	9543033	RUTSCHNABE GR. 1 RUFLEX	SAFETY CLUTCH COMPL.SIZE1 RUFLEX	COUPL.D.FRICTION COMPL. RUFLEX
W (1) V	10	9615418	REIBBELAG F.RUTSCHKUPPLUNG 3 MM	FRICTION LINING 3 MM	GARNITURE DE FRICTION3 MM
W (1) V	10	9554565	REIBBELAG F.RUTSCHKUPPLUNG 6 MM	FRICTION LINING 6 MM	GARNITURE DE FRICTION 6 MM
W (1)	10	9538288	TELLERFEDER	DISK SPRING	RESSORT A DISQUE
	11	0355110	PASSFEDER DIN 6885 1.4301 A 8X7X30	FEATHER KEY 8 X 7 X 30 DIN 6885,4301	RESSORT D'AJUSTAGE 8X7X30' DIN 6885 4301
	12	8250310	BLECHFLANSCH 120X120X2 4301	SHEET FLANGE 120X120X2 4301	BRIDE EN TOLE 120X120X2 4301
	13	8250215	BLECHVERSTÄRKUNG KPL. MIT SCHRAUBEN	COMPLETE REINFORCING SHEET WITH SCREWS	RENFORCEMENT COMPLET EN TOLE AVEC VIS
	14	0343015	SICHERUNGSRING DIN471 1.4034 V2A 25MM	CIRCLIP DIN 471 1.4034 V2A 25 MM	CIRCLIP DIN471 1.4034 V2A 25 MM
	15	8100278	U-SCHEIBE 4301 D=37 X D=27 X 1	SUPPORT DISC D=37XD=27X1 4301 B230-42.00.08.5	RONDELLE D=37XD=27X1 4301 B230-42.00.08.5
	16	0355106	PASSFEDER DIN 6885 1.4301 A 8X7X25	FEATHER KEY 8 X 7 X 25 DIN 6885,4301	RESSORT D'AJUSTAGE 8X7X25 DIN 6885 4301
W (2)	17	8660265	LAGERFLANSCH D=80X40 WERST. - S - WELLEND=25	FLANGE FOR BEARING D=80X40, "S", D=25	FLASQUE A PALIER D=80X40 MATIERE „S“ ØARBRE=25

20.01 KETTENRÄDER



20.01 CHAIN WHEEL

20.01 ROUE DE CHAÎNE

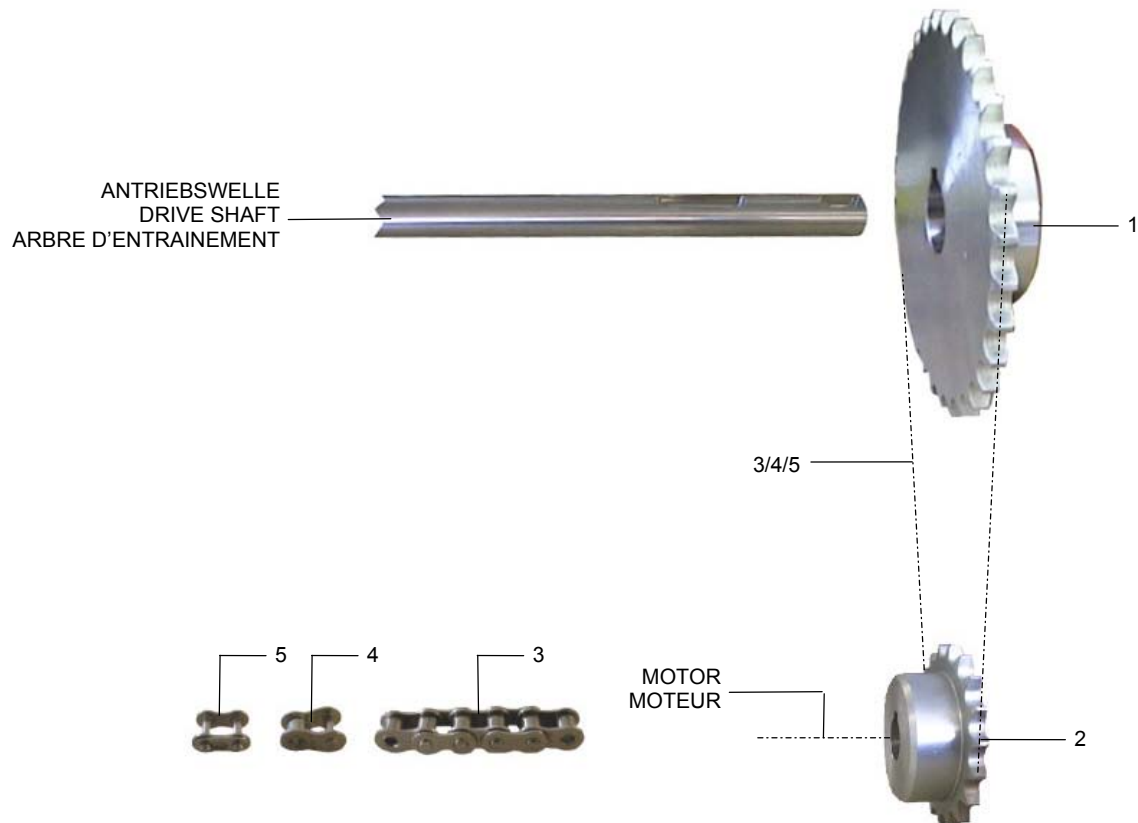

POS	IDENT. NR. IDENT. NO.	BEZEICHNUNG	DESIGNATION	DESIGNATION
1	8660473	KETTENRADSCHIEBE 1/2" Z38 Ø44 STVZ	CHAIN WHEEL DISC 1/2" Z38 Ø44 STVZ	DISQUE DE ROUE DE CHAÎNE 1/2" Z38 Ø44 STVZ
2		2-TANK-MASCHINE	2-TANK-MACHINE	2-BAC-MACHINE
	8660451	KETTENRAD MIT NUT 1/2" Z28 Ø25 STVZ	CHAIN WHEEL 1/2" Z28 Ø25 STVZ	ROUE DE CHAÎNE 1/2" Z28 Ø25 STVZ
		3-TANK-MASCHINE	3-TANK-MACHINE	3-BAC-MACHINE
	0435139	KETTENRAD MIT NUT 1/2" Z32 Ø25 STVZ	CHAIN WHEEL 1/2" Z32 Ø25 STVZ	ROUE DE CHAÎNE 1/2" Z32 Ø25 STVZ
		4-TANK-MASCHINE	4-TANK-MACHINE	4-BAC-MACHINE
	9537649	KETTENRAD MIT NUT 1/2" Z36 Ø25 STVZ	CHAIN WHEEL 1/2" Z36 Ø25 STVZ	ROUE DE CHAÎNE 1/2" Z36 Ø25 STVZ
W (1M)	3	0435005	ROLLENKETTE ST 1/2"	CHAÎNE A ROULEAU ST 1/2"
W (5)	4	0435007	KETTENKROEPFGLIED 1/2"	ELEMENT DE CHAÎNE ONDULE 1/2"
W (10)	5	0435006	KETTENSCHLUSSGLIED 1/2"	ELEMENT FINAL DE CHAÎNE 1/2"

21.01 UMLENKUNG



21.01 REVERSE UNIT

21.01 RENVOI

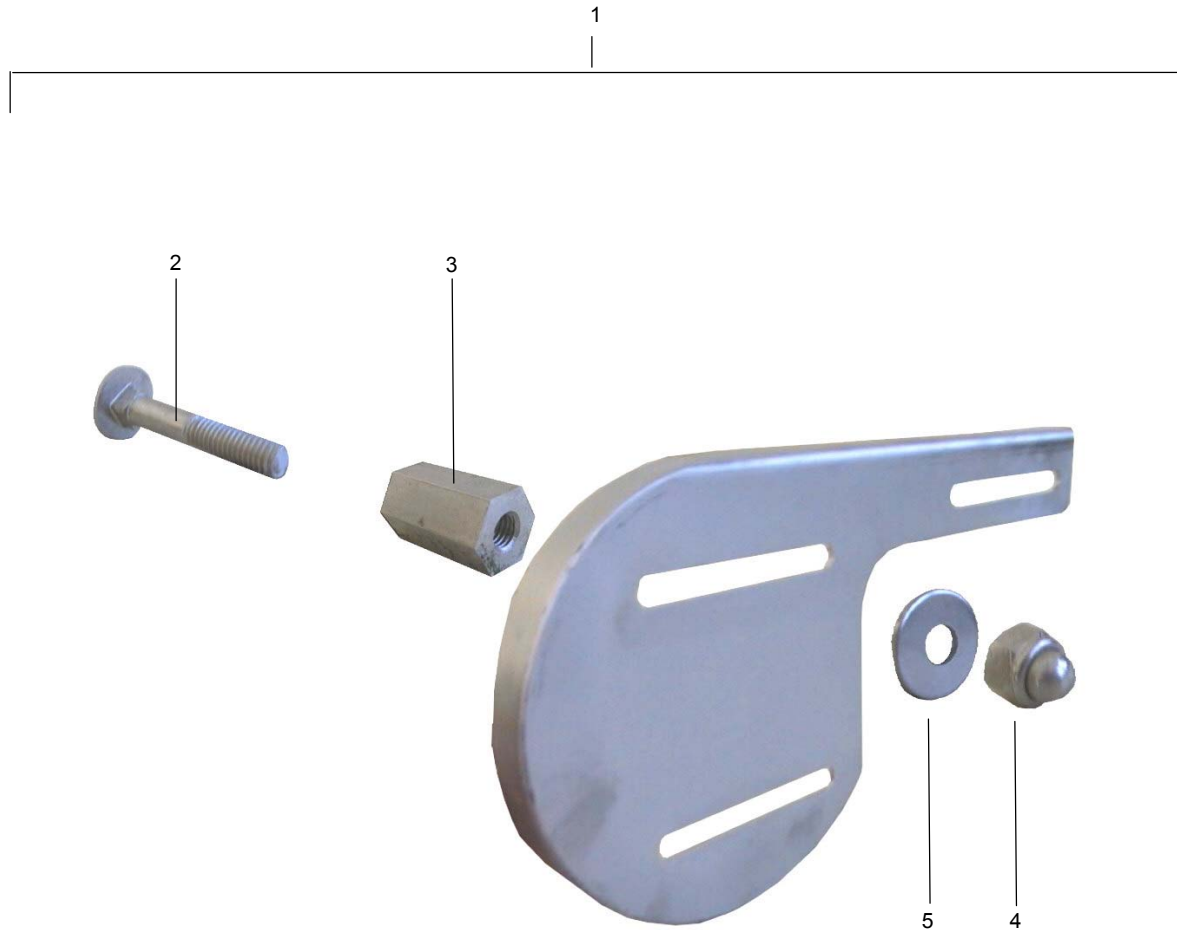

POS	IDENT. NR. IDENT. NO.	BEZEICHNUNG	DESIGNATION	DESIGNATION
1	9503966-03	UMLENKSCHIEBE LINKS	REVERSE DISK LEFT	DISQUE DE RENVOI GAUCHE
	9503966-04	UMLENKSCHIEBE RECHTS	REVERSE DISK RIGHT	DISQUE DE RENVOI DROITE
2	9505909	SCHRAUBE M8X45	SCREW M8X45	VIS M8X45
3	9503964	DISTANZKLOTZ SW17X30	DISTANCE BLOCK SW17X30	BLOC DE DISTANCE SW17X30
4	0336052	HUTMUTTER M8	CAP NUT M8	ECROU BORGNE M8
5	0340055	SCHEIBE	DISK	DISQUE

22.01 ABSAUGGEBLÄSE Ø400



22.01 EXTRACTION FAN Ø400

22.01 VENTILATEUR D'ASPIRATION Ø400



POS	IDENT. NR. IDENT. NO.	BEZEICHNUNG	DESIGNATION	DESIGNATION
W (1)	1	GEBLÄSE AXIAL SIEHE ELEKTROSCHALTPLAN	FAN AXIAL SEE ELECTRICAL WIRING DIAGRAM	VENTILATEUR AXIAL VOIR SCHEMA ELECTRIQUE

24.01 TROCKNUNG (DAMPFBEHEIZT)



24.01 DRYING (STEAM HEATED)

24.01 SECHAGE (CHAUFFAGE VAPEUR A BASSE PRESSION)

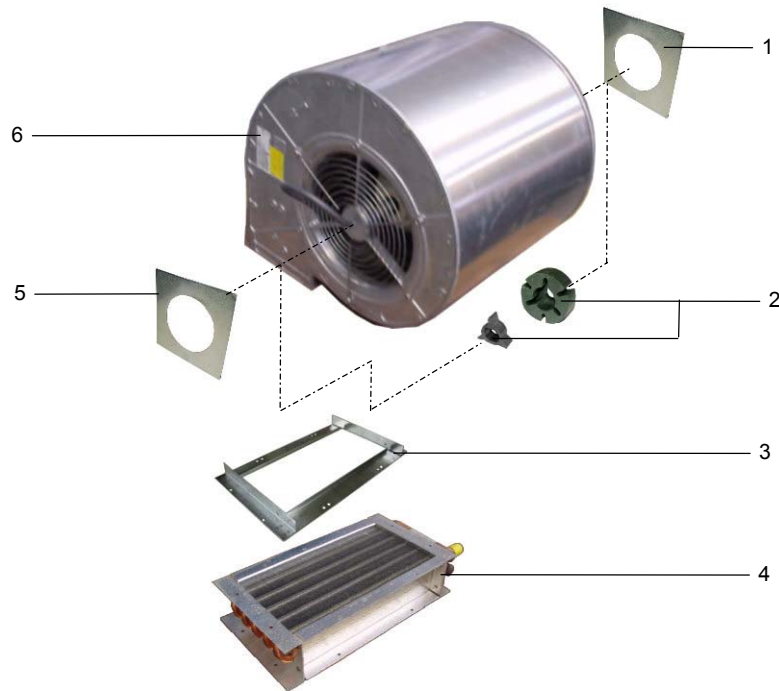

POS	IDENT. NR. IDENT. NO.	BEZEICHNUNG	DESIGNATION	DESIGNATION
	1	LÜFTERDROSSEL GESCHLITZT 190X190	THROTTLE FOR FAN, SLIT 190X190	CLAPET DE REGULATION A SENT P. VENTILATEUR 190X190
W (2) V	2	LAGERBUCHSE 1610-023 00273340 MIT EINSATZ	BEARING BUSH 1610-023 00273340	COUSSINET 1610-023 00273340
	3	RAHMEN FÜR GEBLÄSE 1.4301 440X250X30	FRAME FOR FAN 1.4301 440X250X30	CADRE DE VENTILATEUR 1.4301 440X250X30
W (1)	4	LUFTERHITZER WAAGRECHTER EINBAU SIEHE INSTALLATIONSPLAN	HEATING REGISTER HORIZONTAL INSTALLATION SEE INSTALLATION DIAGRAM	REGISTRE DE CHAUFFAGE INSTALLATION HORIZONTALE VOIR DIAGRAMME D'INSTALLATION
	5	LÜFTERDROSSEL 190X190	THROTTLE FOR FAN 190X190	CLAPET DE REGULATION A SENT POUR VENTILATEUR 190X190
W (1)	6	RADIALGEBLÄSE SIEHE ELEKTROSCHALTPLAN	RADIAL BLOWER SEE ELECTRIC WIRING DIAGRAM	VENTILATEUR RADIAL VOIR SCHEMA ELECTRIQUE

24.02 TROCKNUNG (ELEKTRISCH BEHEIZT)

24.02 DRYING (ELECTRICALLY HEATED)

24.02 SECHAGE (CHAUFFAGE ELECTRIQUE)

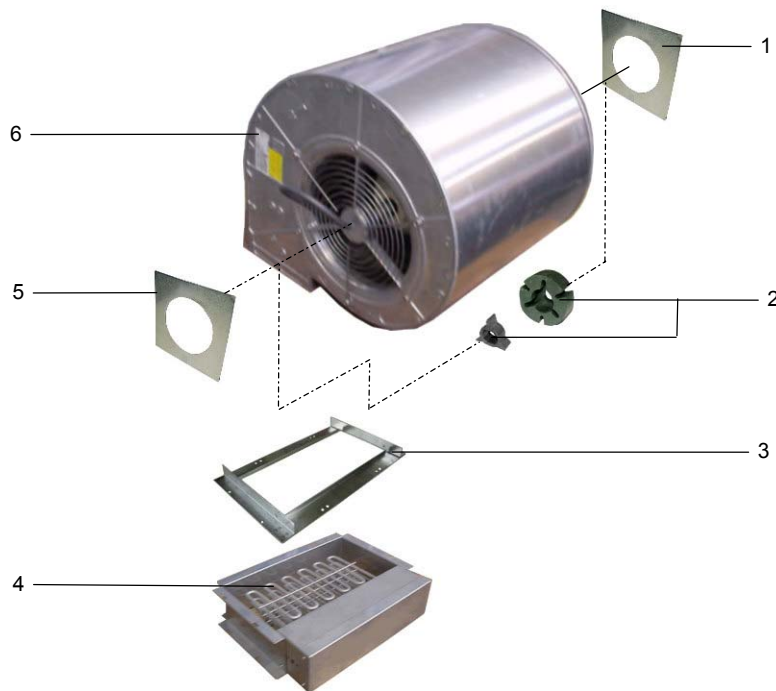

POS	IDENT. NR. IDENT. NO.	BEZEICHNUNG	DESIGNATION	DESIGNATION
	1	LÜFTERDROSSEL GESCHLITZT 190X190	THROTTLE FOR FAN, SLIT 190X190	CLAPET DE REGULATION A SENT P. VENTILATEUR 190X190
W (2) V	2	LAGERBUCHSE 1610-023 00273340 MIT EINSATZ	BEARING BUSH 1610-023 00273340	COUSSINET 1610-023 00273340
	3	RAHMEN FÜR GEBLÄSE 1.4301 440X250X30	FRAME FOR FAN 1.4301 440X250X30	CADRE DE VENTILATEUR 1.4301 440X250X30
W (2)	4	HEIZKÖRPER SIEHE ELEKTROSCHALTPLAN	HEATING ELEMENT SEE ELECTRIC WIRING DIAGRAM	RESISTANCE VOIR SCHEMA ELECTRIQUE
	5	LÜFTERDROSSEL 190X190	THROTTLE FOR FAN 190X190	CLAPET DE REGULATION A SENT POUR VENTILATEUR 190X190
W (1)	6	RADIALGEBLÄSE SIEHE ELEKTROSCHALTPLAN	RADIAL BLOWER SEE ELECTRIC WIRING DIAGRAM	VENTILATEUR RADIAL VOIR SCHEMA ELECTRIQUE

22.5.2 BOILER ELT., EXTERNE THERMOSTATREGELUNG



22.5.2 BOILER ELT., EXTERNAL THERMOSTAT REGULATION

22.5.2 SURCHAUFFEUR ELT., AVEC REGULATION THERMOSTAT EXTERNE

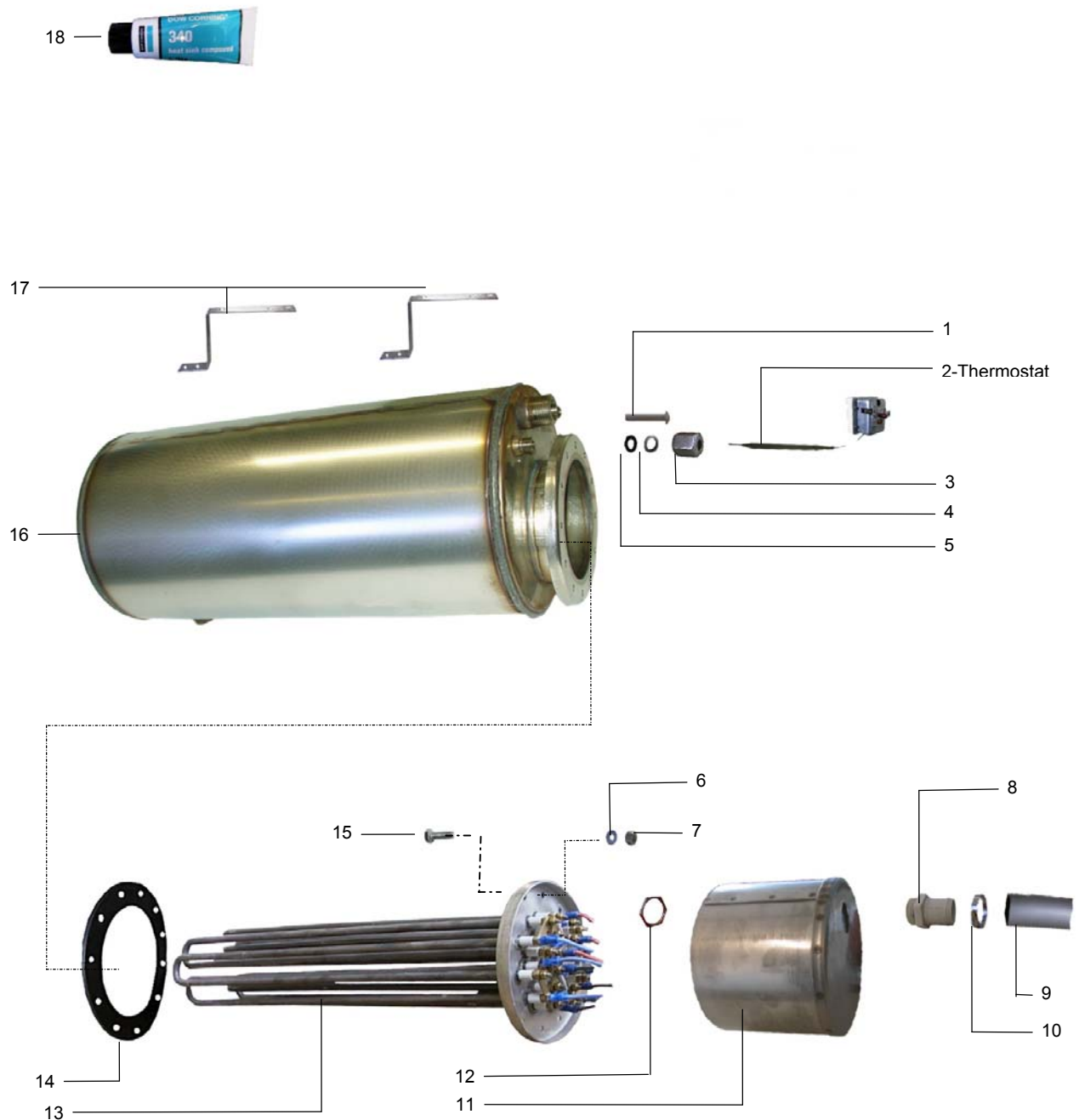

22.5.2 BOILER ELT., EXTERNE THERMOSTATREGELUNG



22.5.2 BOILER ELT., EXTERNAL THERMOSTAT REGULATION

22.5.2 SURCHAUFFEUR ELT., AVEC REGULATION THERMOSTAT EXTERNE

POS	IDENT. NR. IDENT. NO.	BEZEICHNUNG	DESIGNATION	DESIGNATION	
	1	0360012	HALBRUNDNIET	ROUND HEAD RIVET	RIVET A TETE RONDE
W (2)	2	THERMO- STAT	SIEHE ELEKTROSCHALTPLAN	SEE ELECTRIC DIAGRAM	VOIR SCHEMA ELECTRIQUE
	3	9502591	ÜBERWURFMUTTER	SLEEVE NUT	ECROU RACCORD
	4	9502573	SCHEIBE	DISK	DISQUE
W (10)	5	9502586	O-RING	O-RING	BAGUE
	6	0341012	FEDERING	SPRING RING	BAGUET DE RESSORT
	7	0335043	SKT.MUTTER M6	HEXAGON NUT M6	ECROU A 6 PANS M6
	8	9529498	VERSCHRAUBUNG	SCREWING	VISSAGE
	9	9529487	SCHLAUCH	HOSE	TUYAU
	10	9535169	SCHLAUCHKLEMME 20-32	HOSE WIRE CLAMP 20-32	COLLIER DE SERRAGE 20-32
	11	9537207	SCHUTZABDECKUNG	PROTECTION COVER	RECOUVREMENT DE PROTECTION
	12	0162104	GEGENMUTTER	COUNTERNUT	CONTRE-ECROU
	13	HEIZUNG	SIEHE ELEKTROSCHALTPLAN	SEE ELECTRIC WIRING DIAGRAM	VOIR SCHEMA ELECTRIQUE
W (2)	14	0408229	DICHTUNG	PACKING	JOINT
	15	0302001	SKT.SCHRAUBE M6X15	SCREW M6X15	VIS M6X15
	16	8103631	BOILER	BOILER	SURCHAUFFEUR
	17	8103636	BEFESTIGUNGSWINKEL	FIXATION ANGLE	ANGLE DE FIXATION
	18	0108024	LEITFÄHIGKEITSPASTE	CONDUCTIVE PASTE	PATE DE CONDUCTION

10.2 WÄRMETAUSCHER

10.2 HEAT EXCHANGER

10.2 ECHANGEUR DE CHALEUR

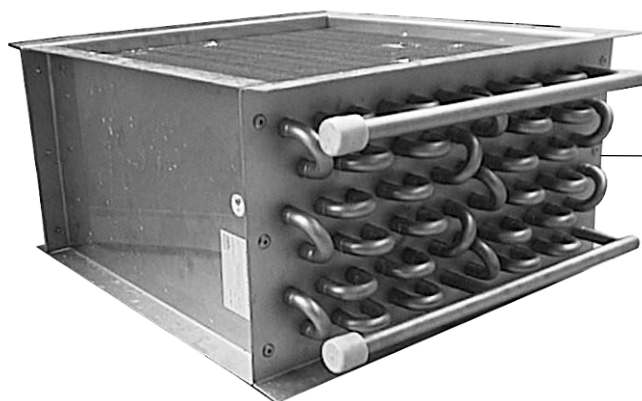

0254026 / 1.4435
9517229 / Cu

IDENT.-NR. IDENT.-NO.	BEZEICHNUNG	DESIGNATION	DESIGNATION
--------------------------	-------------	-------------	-------------

0254026	KÜHLER 1.4435	COOLER 1.4435	REFROIDISSEUR 1.4435
9517229	KÜHLER CU	COOLER CU	REFROIDISSEUR CU

NEW COIL PART NUMBER - 9623385