

Ersatzteilliste
Spare part list
Liste de pièces détachées



Reinigungs- und Desinfektionsautomat
Washer and disinfector
Automates de lavage et de désinfection

KD

10.2 AP
20.2 AP
30.2 AP
40.2 AP

DT-NDV
DT-NDD



INHALTSVERZEICHNIS

CONTENTS

SOMMAIRE

ERSATZTEILE ALLGEMEIN	SPARE PARTS LIST	LISTE DE PIECES DETACHEES
WASSERTANK	SPARE PARTS WATER TANK	PIECES DETACHEES RESERVOIR D'EAU
AP-SYSTEM	SPARE PARTS AP-SYSTEM	PIECES DETACHEES SYSTEME AP
PUMPE	SPARE PARTS PUMP	PIECES DETACHEES POMPE
MAGNETVENTILE SCHMUTZFÄNGER	SPARE PARTS SOLENOID VALVE DIRT TRAP	PIECES DETACHEES ELECTROVANNE FILTRE
DÜSEN	SPARE PARTS NOZZLES	PIECES DETACHEES GICLEUR
DAMPFERZEUGER	SPARE PARTS EVAPORATOR	PIECES DETACHEES EVAPORATEUR
ELEKTROTEILE	SPARE PARTS ELECTRICAL PARTS	PIECES DETACHEES ELECTRIQUES
DOSIERSYSTEM DEK, DR	SPARE PARTS DOSING UNIT DEK, DR	PIECES DETACHEES SYSTEME DE DOSAGE DEK, DR
GEFÄßHALTER, KÖRBE	SPARE PARTS VESSEL HOLDER, BASKETS	PIECES DETACHEES SUPPORT BOCAUX, PANIERS
SPÜLKASTEN	FLUSHING BOX	RESERVOIR D'EAU POUR RINCAGE
AUTOMATISCHE TÜRÖFFNUNG KD.2 AT	AUTOMATIC DOOR OPENING KD.2 AT	OUVERTURE AUTOMATIQUE DES PORTES KD.2 AT
AUTOMATISCHE TÜRÖFFNUNG KD.2 AT, LAGERWINKEL	AUTOMATIC DOOR OPENING KD.2 AT, BEARING ANGLE	OUVERTURE AUTOMATIQUE DES PORTES KD.2 AT, ANGLE DE SUPPORT
AUTOMATISCHE TÜRÖFFNUNG KD.2 AT, FUSSPEDAL	AUTOMATIC DOOR OPENING KD.2 AT, PEDAL	OUVERTURE AUTOMATIQUE DES PORTES KD.2 AT, PEDALE
MECHANISCHE TÜRÖFFNUNG KD.2 MT	MECHANICAL DOOR OPENING KD.2 MT	OUVERTURE MECANIQUE DES PORTES KD.2 MT
MECHANISCHE TÜRÖFFNUNG KD.2 MT, VERRIEGELUNG	MECHANICAL DOOR OPENING KD.2 MT, LOCK	OUVERTURE MECANIQUE DES PORTES KD.2 MT, VERROUILLAGE

KENNZEICHNUNG DER ERSATZTEILE

* / V	DIESE TEILE EMPFEHLEN WIR AUF LAGER ZU LEGEN!
V	VERSCHLEISSTEIL!

SPECIAL MARKS OF SPARES

WE RECOMMEND TO STORE THESE PARTS!
WEAR AND TARE PART!

MARQUAGE SPECIALES DES PIECES

NOUS RECOMMANDONS DE PRENDRE CES PIECES EN STOCK!
PIÈCE D'USURE!

SPARE PARTS

PIECES DE DETACHEES

IDENT.-NR. IDENT.-NO.	BEZEICHNUNG	DESIGNATION	DESIGNATION
8302869	TÜR OBEN, OHNE RS, KD10.2/KD20.2	UPPER DOOR WITHOUT RIM RINSING KD10.2/KD20.2	PORTE SUPERIEURE AVEC RINCAGE DE BORD KD10.2/KD20.2
8302868	TÜR OBEN, MIT RS, KD10.2/KD20.2	UPPER DOOR WITH RIM RINSING KD10.2/KD20.2	PORTE SUPERIEURE SANS RINCAGE DE BORD KD10.2/KD20.2
8302851	TÜR INSPEKTION UNTEN, KD10.2, KD20.2	LOWER DOOR INSPECTION KD10.2, KD20.2	PORTE INFERIEURE INSPECTION KD10.2, KD20.2
9551074	TÜR INSPEKTION MIT DICHTPROFIL KD30.2 MIT WC	INSPECTION DOOR WITH SEAL PROFILE KD30.2 WITH WC	PORTE D'INSPECTION AVEC PROFILÉ D'ÉTANCHEITÉ KD 30.2 AVEC WC
9553342	TÜR INSPEKTION MIT DICHTPROFIL KD30.2 OHNE WC	INSPECTION DOOR WITH SEAL PROFILE KD30.2 WITHOUT WC	PORTE D'INSPECTION AVEC PROFILE D'ETANCHEITE KD30.2 SANS WC
9554446	FRONTBLLENDE UNTEN IP X5, KD30.2	LOWER FRONT PANEL IP X5 KD30.2	PANNEAU FRONTAL INFERIEUR IP X5 KD30.2
9530905	FRONBLLENDE UNTEN, KD40.2	LOWER FRONT PANEL KD40.2	PANNEAU FRONTAL INFERIEUR KD40.2
8303913	TÜR INSPEKTION, OHNE RS, KD40.2	DOOR INSPECTION WITHOUT RIM RINSING KD40.2	PORTE INSPECTION SANS RINCAGE DE BORD KD40.2
8303912	TÜR INSPEKTION, MIT RS, KD40.2	DOOR INSPECTION WITH RIM RINSING KD40.2	PORTE INSPECTION AVEC RINCAGE DE BORD KD40.2
* 0457040	ZYLINDERSCHLOSS	CYLINDER LOCK	SERRURE CYLINDRIQUE
0457041	SCHLOSSZUNGE	LATCH LOCK	PENE DEMI-TOUR SERRURE
* 9500322	SCHLÜSSEL FÜR ZYLINDERSCHLOSS 0457040	KEY FOR CYLINDER LOCK	CLE P. SERRURE CYLINDRIQUE
8302584	TÜR FÜR KAMMER KOMPL.	CHAMBER DOOR COMPLETE	PORTE DE CHAMBRE COMPLETE
8304232	TÜR FÜR KAMMER MT	CHAMBER DOOR MT	PORTE DE CHAMBRE MT
8304171	TÜR FÜR KAMMER AT	CHAMBER DOOR AT	PORTE DE CHAMBRE AT
8302897	TÜRGRIFF METALL	METAL DOOR HANDLE	POIGNEE DE PORTE METALLIQUE
8304378	TÜR FÜR KAMMER KOMPL. MIT SEITLICHEN SPRITZBLENDEN	CHAMBER DOOR COMPLETE WITH LATERAL SPLASH PROTECTION	PORTE DE CHAMBRE COMPLETE AVEC PROTECTION LATÉRALE CONTRE ECLABOUSSURE
V 9509247	ABDICHTPROFIL FÜR KAMMERTÜR 0.5M	SEALING PROFILE FOR DOOR CHAMBRE 0;5 M	PROFILE D'ETANCHEITE POUR PORTE DE CHAMBRE 0,5 M
0431049	GASDRUCKFEDER	GAS PRESSURE SPRING	RESSORT DE PRESSION GAZEUSE
* 9502210	BOWDENZUG FÜR MT	BOWDEN CABLE	CABLE BOWDEN
9502191	FEDER FÜR MT-ZYLINDER	SPRING FOR CYLINDER	RESSORT POUR CYLINDRE
8302173	GERUCHVERSCHLUSS, ABGANG ZUR WAND, KD10.2, 450 TIEF	SIPHON WALL CONNECTION KD 10.2 450 DEEP	SYPHON CONNEXION MURALE KD10.2 450 PROFOND
8303951	GERUCHVERSCHLUSS, ABGANG WAND, KD10.2/KD40.2, 600 TIEF	SIPHON WALL CONNECTION KD10.2/KD40.2 600 DEEP	SYPHON CONNEXION MURALE KD10.2/KD40.2 600 PROFOND
8304123	GERUCHVERSCHLUSS, ABGANG ZUM BODEN, KD20.2	SIPHON FLOOR CONNECTION KD20.2	SYPHON CONNEXION AU SOL KD20.2
8303642	GERUCHVERSCHLUSS, KD30.2	SIPHON KD30.2	SYPHON KD30.2
0296007	CV-VERBINDER DN100	CV-CONNECTION DN 100	CONNECTION DE SYPHON DN 100
* 8305007	AUSGUSS STECKSIEB DN 70	DRAIN SIEVE DN70 SLOPSINK	CRIBLE DU VIDANGE VIDOIR DN70

WASSERTANK

WATERTANK

RESERVOIR D'EAU

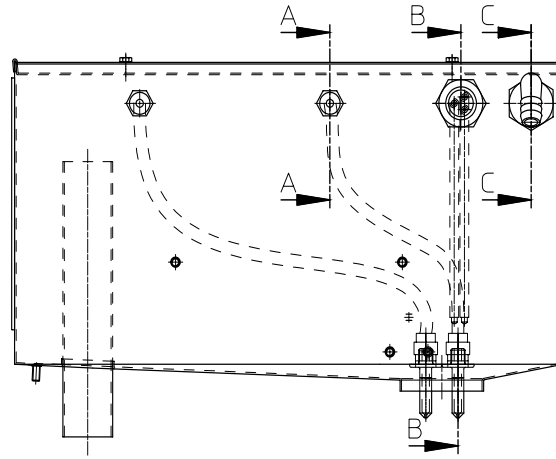

9547519
8303794

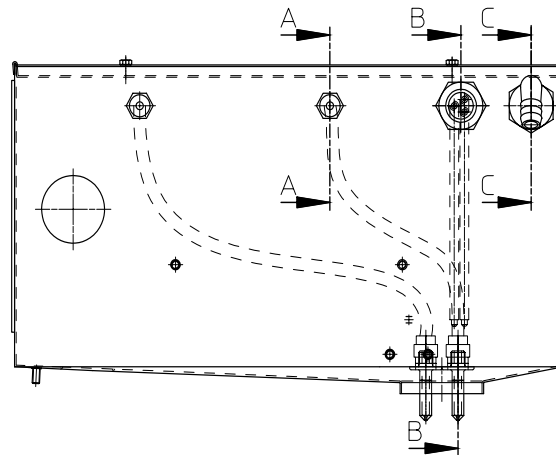

9547533
8303906

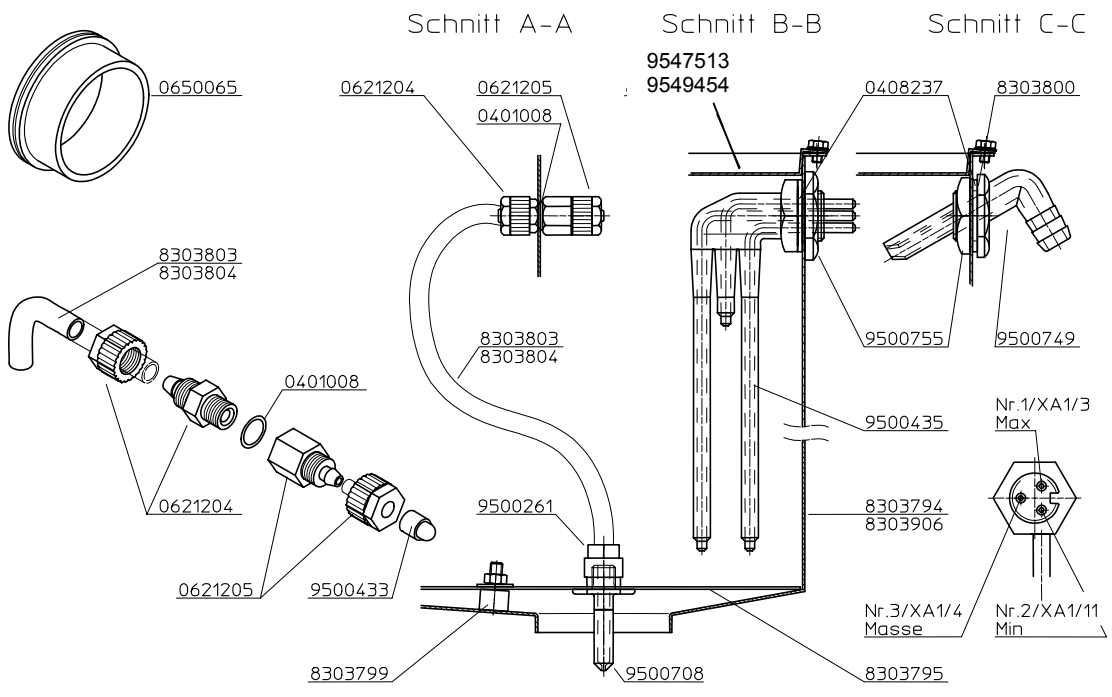

WASSERTANK

WATERTANK



RESERVOIR D'EAU

IDENT.-NR. IDENT.-NO.	BEZEICHNUNG	DESIGNATION	DESIGNATION
9547519	WASSERTANK KD10/20/30.2 AP	WATER TANK COMPLETE KD10/20/30.2 AP	RESERVOIR D'EAU KD10/20/30.2 AP COMPLETE
9547533	WASSERTANK KD40.2 AP	WATER TANK KD40.2 AP COMPLETE	RESERVOIR D'EAU KD40.2 AP COMPLETE
8303794	WASSERTANK-SCHWEISSTEIL KD10/20/30.2 AP	WATER TANK WITHOUT ACCESSORIES KD10/20/30.2 AP	RESERVOIR D'EAU SANS ACCESSOIRES KD10/20/30.2 AP
8303906	WASSERTANK-SCHWEISSTEIL KD40.2 AP	WATER TANK WITHOUT ACCESSORIES KD40.2AP	RESERVOIR D'EAU SANS ACCESSOIRES KD40.2AP
* 9500749	FÜLLSTUTZEN	FILL SOCKET	MANCHON DE REMPLISSAGE
* 0408237	FLACHDICHTUNG $\varnothing 30 \times \varnothing 21 \times 2$	FLAT PACKING $\varnothing 30 \times \varnothing 21 \times 2$	GARNITURE PLATE $\varnothing 30 \times \varnothing 21 \times 2$
* 8303800	SCHEIBE $\varnothing 4,3$	DISC D=4,3	DISQUE D 0 4,3
* 9500755	MUTTER 1/2"	NUT 1/2"	ECROU 1/2"
9500435	NIVEAUELEKTRODE	LEVEL ELECTRODE	ELECTRODE A NIVEAU
* 9500708	DOSIERNIPPEL	DOSING NIPPLE	RACCORD-DOSEUR
* 9500261	SCHLAUCHVERSCHRAUBUNG	HOSE SCREWING	RACCORD A VIS POUR TUYEAU
* 8303803	SCHLAUCH FÜR DEK $\varnothing 8 \times 1 \times 230$	HOSE FOR DEK $\varnothing 8 \times 1 \times 230$	TUYEAU POUR DEK $\varnothing 8 \times 1 \times 230$
* 8303804	SCHLAUCH FÜR DR $\varnothing 8 \times 1 \times 300$	HOSE FOR DR $\varnothing 8 \times 1 \times 300$	TUYEAU POUR DR $\varnothing 8 \times 1 \times 300$
* 0621204	SCHLAUCHVERSCHRAUBUNG	HOSE SCREWING	RACCORD A VIS POUR TUYEAU
* 0621205	SCHLAUCHVERSCHRAUBUNG	HOSE SCREWING	RACCORD A VIS POUR TUYEAU
* 9500433	SCHUTZKAPPE	PROTECTING CAP	CAPOT PROTECTEUR
8303799	DISTANZBUCHSE	BUSHING	DOUILLE
8303795	ABDECKBLECH	COVER PLATE	PLAQUE DE RECOUVREMENT
* 0175506	KABELBINDERHALTER	FIXING FOR CABLE CONNECTOR	FIXATION POUR RACCORD CABLE
9547513	DECKEL FÜR WASSERTANK	COVER FOR WATER TANK	COUVERCLE POUR RESERVOIR D'EAU
9549454	DROSSEL	THROTTLE	CLAPET D'ÉTRANGLEMENT
0401008	O-RING 9,3X2,4	O-RING 9,3X2,4	O-BAGUE 9,3X2,4

AP-SYSTEM

AP-SYSTEM

SYSTEME AP

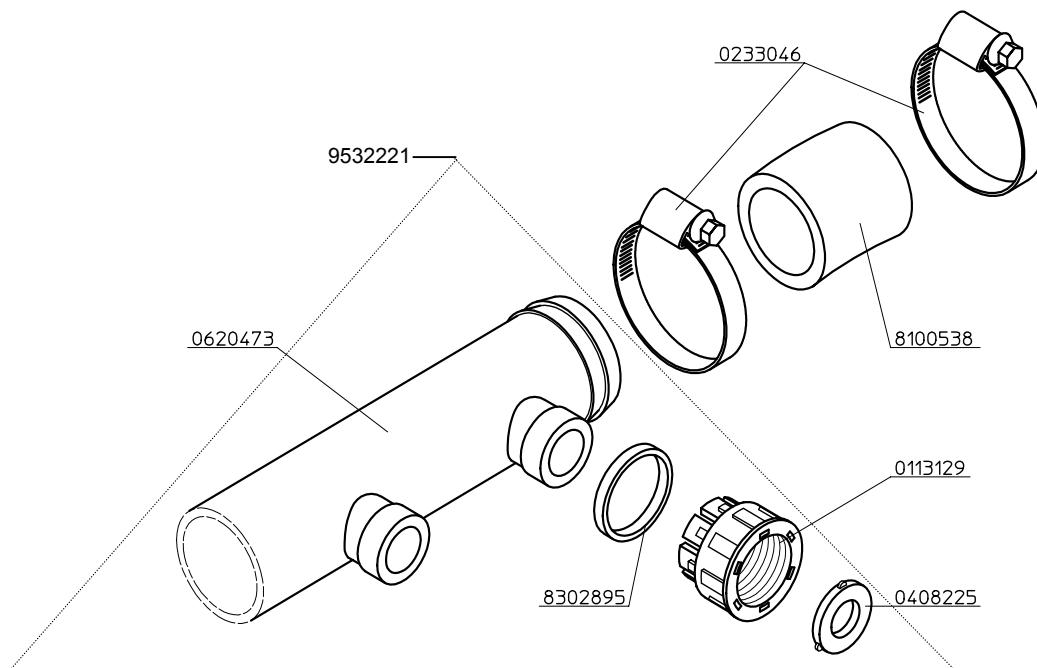
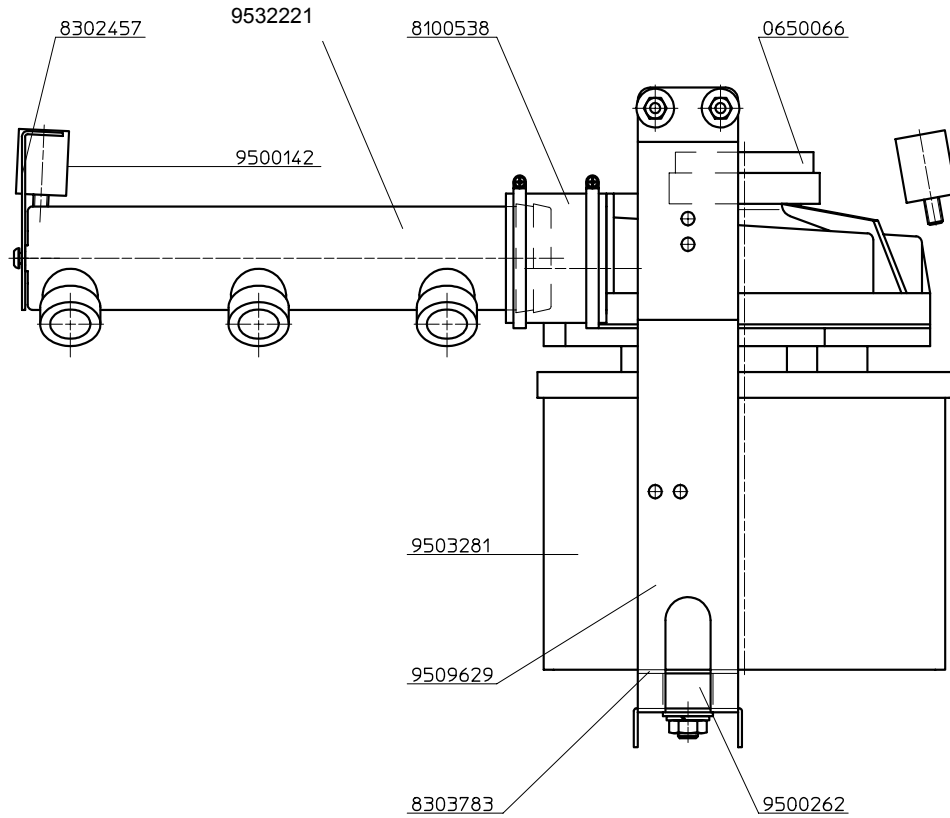

SYSTEME AP

IDENT.-NR. IDENT.-NO.	BEZEICHNUNG	DESIGNATION	DESIGNATION
* 9532221	VERTEILERROHR KPL.	DISTRIBUTING PIPE KPL.	TUYEAU DISTRIBUTEUR KPL.
0620473	VERTEILERROHR	DISTRIBUTING PIPE	TUYEAU DISTRIBUTEUR
* 8302895	HALTERING	FIXATION RING	BAGUE DE FIXATION
V 0408225	DICHTUNG	SEAL	ETANCHEITE
* 0113129	ANSCHLUSSTÜCK	CONNECTION PIECE	PIECE DE CONNEXION
8100538	SCHLAUCH FÜR DRUCKSTUTZEN φ40*5*42	HOSE FOR PRESSURE JOINT φ40*5*42	TUYEAU POUR RACCORD DE REFOULEMENT φ40*5*42
* 0233046	SCHLAUCHKLEMME 32-50	HOSE CLAMP 32-50	PINCE POUR TUYEAU 32-50
8302457	HALTEBLECH FÜR VERTEILERROHR	FIXATION PANEL FOR DISTRIBUTING PIPE	PANNEAU DE FIXATION POUR TUYEAU DISTRIBUTEUR
9500142	GUMMIPUFFER φ20*25	RUBBER CUSHION φ20*25	BUTOIR EN CAOUTCHOUC φ20*25
9509629	HALTEBLECH FÜR PUMPE	FIXATION PANEL FOR PUMP	PANNEAU DE FIXATION POUR POMPE
8303783	HALTEBLECH FÜR PUMPENABDECKUNG	FIXATION PANEL FOR PUMP COVER	PANNEAU DE FIXATION POUR COUVERCLE DE POMPE
9500262	GUMMIPUFFER φ20*15	RUBBER CUSHION φ20*15	BUTOIR EN CAOUTCHOUC φ20*15
* 0650066	MUFFE FÜR SAUGSTUTZEN	BUSHING FOR CONNECTION PIECE	MANCHON POUR PIECE DE CONNECTION
9503281	VERKLEIDUNG FÜR PUMPE	PUMP CASE	REVETEMENT DE POMPE
8304153	ÜBERLAUF KD10.2/20.2/30.2	STAND PIPE KD10.2/20.2/30.2	SURVERSE KD10.2/20.2/30.2
8304154	ÜBERLAUF KD40.2	STAND PIPE KD40.2	SURVERSE KD40.2
* 0650065	GUMMITÜLLE	RUBBER BUSHING	DOUILLE EN CAOUTCHOUC

WASCHPUMPE



WASHPUMP

POMPE DE LAVAGE

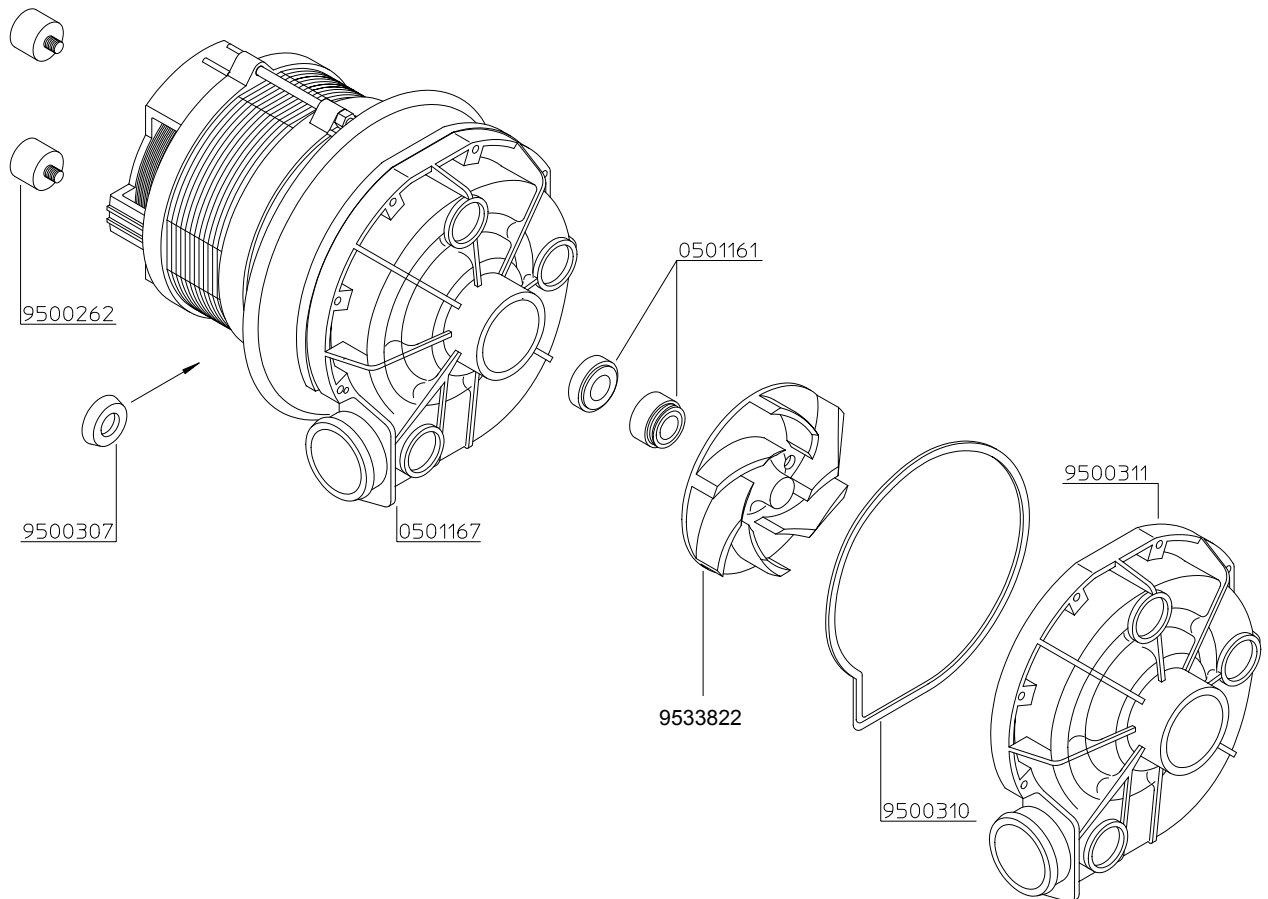

IDENT.-NR. IDENT.-NO.	BEZEICHNUNG	DESIGNATION	DESIGNATION
0501167	PUMPE 0,55KW/4228 230V, 50HZ	PUMP 0,55 KW/4228 230 V,50 HZ	POMPE 0,55 KW/4228 230 V,50 HZ
9500307	RING-SPRITZSCHUTZ	RING FOR SPLASH PROTECTION	BAGUE ANTI-ECLABOUSSURE
* 0501161	GLEITRINGDICHTUNG	SLIDING SEAL	JOINT AXIAL
* 9533822	PUMPENLAUFRAD	PUMP WHEEL	ROUE DE POMPE
* 9500310	DICHTUNG	SEAL	JOINT
9500311	PUMPENGEHÄUSE	PUMP HOUSING	CORPS DE POMPE
8302461	MOTOR-ABDECKUNG	MOTOR COVER	COUVERCLE MOTEUR
* 9500262	SCHWINGMETALLELEMENT/ GUMMIPUFFER	RUBBER-METAL CONNECTION	LIAISON CAOUTCHOUC-METAL
* 0501090	KONDENSATOR 12MF	CONDENSER 12MF	CONDENSEUR 12MF

MAGNETVENTILE / SCHMUTZFÄNGER



SOLENOID VALVES / DIRT TRAP

ELECTROVANNE / FILTRE

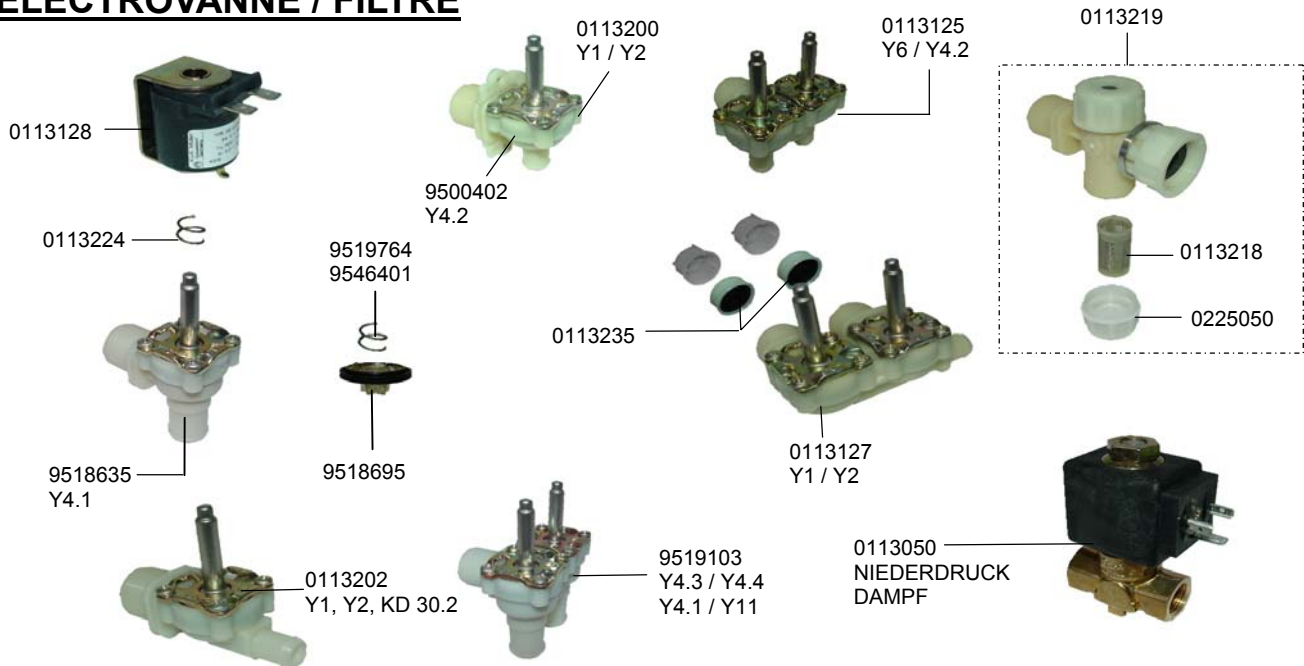

IDENT.-NR. IDENT.-NO.	BEZEICHNUNG	DESIGNATION	DESIGNATION
* 9500402	MAGNETVENTIL EINFACH, DN10 ECKAUSFÜHRUNG Y4.2/DT-NDD	SOLENOID VALVE 1 CONN., DN10 CORNER Y4.2/DT-NDD	ELECTROVANNE 1 CONN., DN10 EXEC. ANGLE Y4.2/DT-NDD
V 9518635	MAGNETVENTIL EINFACH, DN13 ECKAUSFÜHRUNG Y4.1	SOLENOID VALVE 1 CONN., DN13 CORNER Y4.1	ELECTROVANNE 1 CONN., DN13 EXEC. ANGLE Y4.1
* 0113125	MAGNETVENTIL 2-FACH, DN10 ECKAUSFÜHRUNG Y6, Y4.2	SOLENOID VALVE 2 CONN., DN10 CORNER Y6, Y4.2	ELECTROVANNE 2 CONN., DN10 EXEC. ANGLE Y6, Y4.2
V 9519103	MAGNETVENTIL 2-FACH, DN13 ECKAUSFÜHRUNG Y4.3, Y4.4	SOLENOID VALVE 2 CONN., DN13 CORNER Y4.3, Y4.4	ELECTROVANNE 2 CONN., DN13 EXEC. ANGLE Y4.3, Y4.4
* 0113127	MAGNETVENTIL, DN10 ; Y1, Y2	SOLENOID VALVE, DN10 ; Y1, Y2	ELECTROVANNE, DN10 ; Y1, Y2
* 9518695	MEMBRANE FÜR MV DN13, 50 SHORE	MEMBRANE FOR MV DN13, 50 SHORE	MEMBRANE POUR MV DN13, 50 SHORE
* 9519764	DRUCKFEDER 1.4301 DN10	PRESSURE SPRING 1.4301 DN10	RESSORT A PRESSION 1.4301DN10
9546401	DRUCKFEDER 1.4301 DN13	PRESSURE SPRING 1.4301 DN13	RESSORT A PRESSION 1.4301 DN13
* 0113224	MAGNETVENTILFEDER	SPRING FOR SOLENOID VALVE	RESSORT POUR ELECTROVANNE
* 0113128	MAGNETSPULE 24V~, 50-60HZ FÜR AMP-STECKER	COIL 24V~, 50-60HZ FOR AMP-PLUG	BOBINE 24V~, 50-60HZ POUR VICHE-AMPERE
* 0113050	MAGNETVENTIL SV04, 3/8", 230V~,50HZ, FÜR DAMPF	SOLENOID VALVE SV04,3/8" 230 V,50 HZ STEAM	ELECTROVANNE SV04,3/8" 230 V,50 HZ VAPEUR
* 0408225	DICHTUNG FÜR MAGNETVENTIL	SEAL FOR SOLENOID VALVE	JOINT POUR ELECTROVANNE
* 0113235	MENGENREGLER 18 LTR/MIN	REDUCER FOR SOLENOID VALVE 18 LTR/MIN	REDUCTEUR POUR ELECTROVANNE 18 LTR/MIN
* 0621062	MAGNETVENTIL-ABDECKHAUBE	COVER FOR SOLENOID VALVE	CACHE POUR ELECTROVANNE
* 0113219	SCHMUTZFÄNGER KOMPL.	DIRT TRAP COMPL.	FILTRE COMPL.
* 0225050	VERSCHLUSSKAPPE MIT FASSUNG UND O-RING	SEALING CAP WITH HOLDER AND O-RING-SEAL	CAPUCHON AVEC CHASSIS ET JOINT TORIQUE D'ETANCHEITE
V 0113218	SIEB 0,25 MM	SIEVE 0,25 MM	FILTRE 0,25 MM
* 0113200	MAGNETVENTIL EINFACH DN 10 ECKAUSFÜHRUNG Y1,Y2,KD 30.2	SOLENOID VALVE CONN., DN10 CORNER Y1,Y2,KD 30.2	ELECTROVANNE 1 CONN., DN10 EXEC. ANGLE Y1,Y2,KD 30.2
* 0113202	MAGNETVENTIL EINFACH DN 10 Y1,Y2,KD 30.2, DT-NDD	SOLENOID VALVE CONN., DN10 Y1,Y2,KD 30.2, DT-NDD	ELECTROVANNE 1 CONN., DN10 Y1,Y2,KD 30.2, DT-NDD

DÜSEN

NOZZLES

GICLEUR

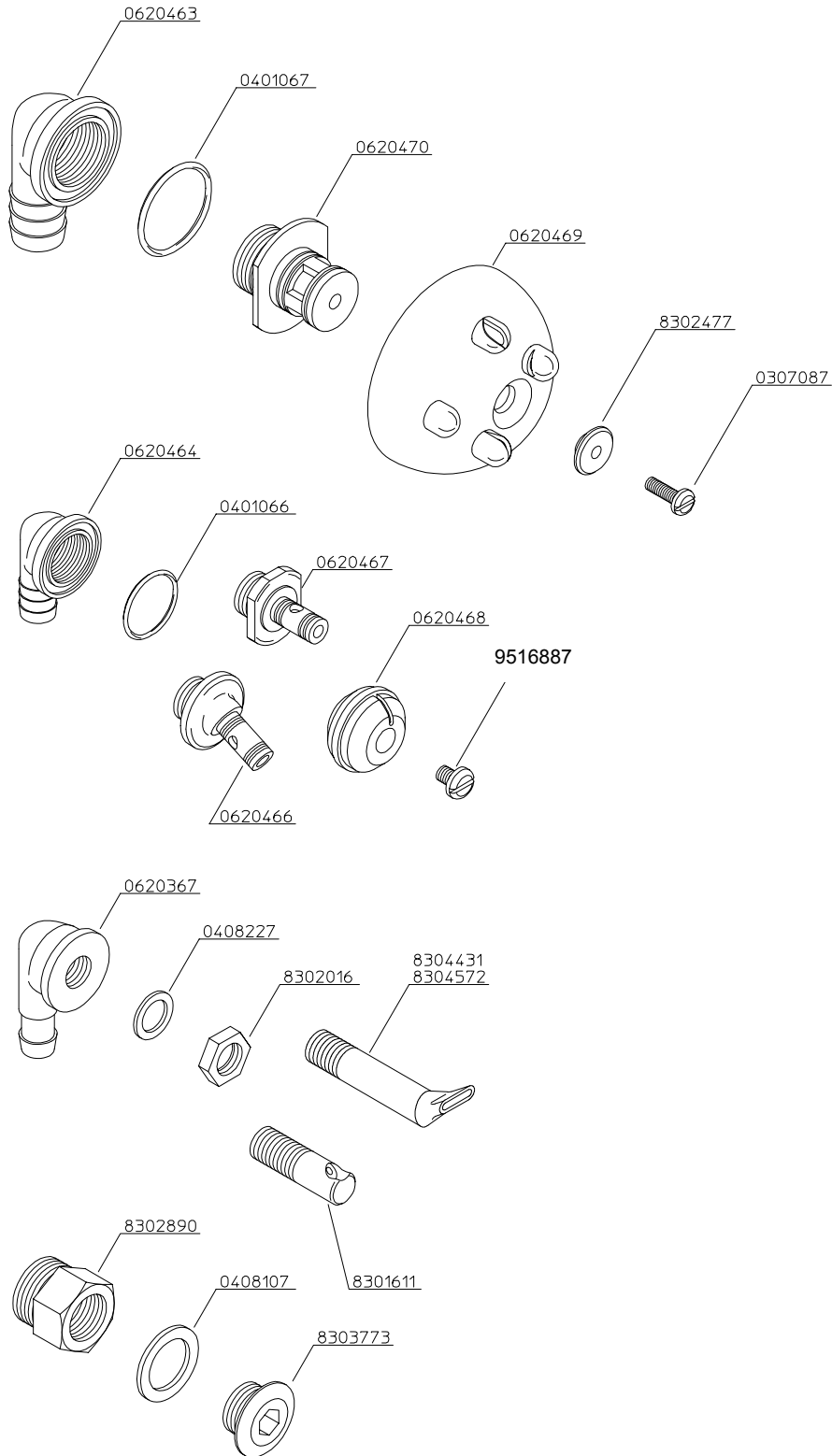

DÜSEN

NOZZLES

GICLEUR



IDENT.-NR. IDENT.-NO.	BEZEICHNUNG	DESIGNATION	DESIGNATION
V 0620469	DREHDÜSE GROSS	ROTATING NOZZLE BIG	GICLEUR DE ROTATION GRAND
V 8302477	DISTANZRING	CONNECTION RING	BAGUE DE CONNEXION
* 0307087	FLACHKOPFSCHRAUBE M5*16	COUNTER SUNK SCREW M5*16	VIS A TETE CONIQUE M5*16
* 0620470	LAGERSTUTZEN FÜR DREHDÜSE GROSS	SOCKET FOR BIG ROTATING NOZZLE	MANCHON POUR GRAND GICLEUR DE ROTATION
* 0401067	O-RING $\varnothing 32*3$	O-RING $\varnothing 32*3$	BAGUE O $\varnothing 32*3$
* 0620463	ANSCHLUSSWINKEL 3/4"	CONNECTION ANGLE 3/4"	ANGLE DE CONNEXION 3/4"
V 0620468	DREHDÜSE KLEIN	ROTATING NOZZLE SMALL	GICLEUR DE ROTATION PETIT
* 0620467	LAGERSTUTZEN GERADE	SOCKET STRAIGHT	MANCHON DROIT
* 0620466	LAGERSTUTZEN 25°	SOCKET 25 DEGREE	MANCHON 25 DEGRE
V 9516887	FLACHKOPFSCHRAUBE M6*8	COUNTER SUNK SCREW M6*8	VIS A TETE CONIQUE M6*8
* 0401066	O-RING $\varnothing 22*3$	O-RING $\varnothing 22*3$	BAGUE O $\varnothing 22*3$
* 0620464	ANSCHLUßWINKEL 3/8"	CONNECTION ANGLE 3/8"	ANGLE DE CONNEXION 3/8"
* 8301611	URINDÜSE	NOZZLE F. URINE BOTTLE	GICLEUR P. URINAL
* 8302016	SECHSKANTMUTTER 1/4"	HEXAGON NUT 1/4"	ECROU HEXAGONAL 1/4"
* 0408227	FLACHDICHTUNG $\varnothing 13*\varnothing 19*1,5$	FLAT SEAL $\varnothing 13*\varnothing 19*1,5$	GARNITURE PLATE $\varnothing 13*\varnothing 19*1,5$
* 0620367	ANSCHLUSSWINKEL KW 1/4"	CONNECTION ANGLE 1/4"	ANGLE DE CONNEXION 1/4"
8304431	SCHNABELDÜSE 50X150°	BEAK NOZZLE 50X150°	GICLEUR A BEC 50X150°
8304572	SCHNABELDÜSE 50X145°	BEAK NOZZLE 50X145°	GICLEUR A BEC 50X145°
V 8303773	NDV-DÜSE	NDV-NOZZLE	GICLEUR-NDV
* 0408107	DICHTUNG $\varnothing 30*\varnothing 21*2$	CONICAL NIPPLE $\varnothing 30*\varnothing 21*2$	BAGUE D'ETANCHEITE $\varnothing 30*\varnothing 21*2$
* 8302890	EINSCHRAUBTEIL 1/2"-3/4"	INSERTION 1/2"-3/4"	PIECE D'INSERTION 1/2"-3/4"

DAMPFERZEUGER

EVAPORATOR

EVAPORATEUR

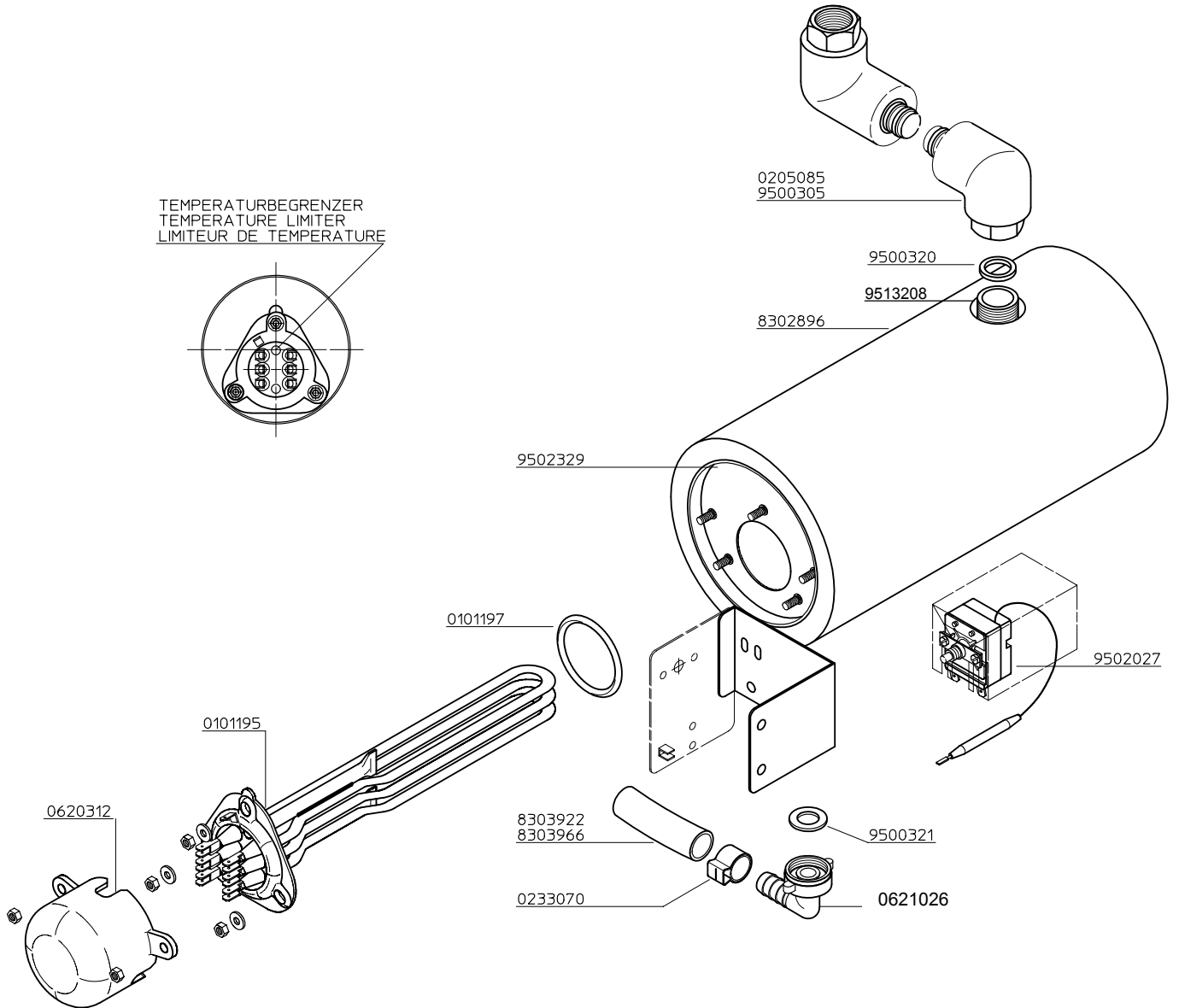

DAMPFERZEUGER

EVAPORATOR

EVAPORATEUR



IDENT.-NR. IDENT.-NO.	BEZEICHNUNG	DESIGNATION	DESIGNATION
9502335	DAMPFERZEUGER KOMPL.3,6KW	EVAPORATOR COMPL. 3,6KW	EVAPORATEUR COMPL. 3,6KW
9502329	DAMPFERZEUGER-GEHÄUSE	HOUSING FOR EVAPORATOR	CORPS POUR EVAPORATEUR
8302896	DAMPFERZEUGER-ISOLIERUNG	INSULATION FOR EVAPORATOR	ISOLATION POUR EVAPORATEUR
* 9502027	TEMPERATURBEGRENZER 3POLIG	TEMPERATURE LIMITER 3-POLE	LIMITEUR DE TEMPERATURE TRIPOLAIRE
* 0101195	RUNDHEIZKÖRPER \varnothing 6,5 3,6KW, 230V	HEATING ELEMENT \varnothing 6,5 3,6KW, 230V	RESISTANCE \varnothing 6,5 3,6KW, 230V
* 0101197	NAPFFLANSCH-DICHTUNGSRING SILIKON \varnothing 58* \varnothing 46*9	PACKING RING FOR FLANGE SILICONE \varnothing 58* \varnothing 46*9	BAGUE D'ETANCHEITE P. FLASQUE SILICONE \varnothing 58* \varnothing 46*9
* 0620312	ABDECKKAPPE FÜR HEIZKÖRPER	COVERING CAP F. HEATING ELEMENT	COUVERCLE P. RESISTANCE
* 0205085	WELLROHR ISOLIERT KD20.2AT/K	CORRUGATED PIPE INSULATED KD20.2AT/K	TUBE ONDULE ISOLE KD20.2AT/K
* 9500305	WELLROHR ISOLIERT KD40.2	CORRUGATED PIPE INSULATED KD40.2	TUBE ONDULE ISOLE KD40.2
* 9500320	DICHTUNG \varnothing 24* \varnothing 15*3 (WELLROHR)	CONICAL NIPPLE \varnothing 24* \varnothing 15*3	BAGUE D'ETANCHEITE \varnothing 24* \varnothing 15*3
V 0621026	SCHLAUCHANSCHLUSS	HOSE CONNECTION	RACCORD POUR TUYEAU
V 9500321	DICHTUNG \varnothing 24* \varnothing 14*2 (FÜLLANSCHLUSS)	CONICAL NIPPLE \varnothing 24* \varnothing 14*2	BAGUE D'ETANCHEITE \varnothing 24* \varnothing 14*2
V 0233070	1-OHR-KLEMME \varnothing 22,6	CLAMP 1 LUG \varnothing 22,6	BORNE 1 OREILLE \varnothing 22,6
* 8303922	SCHLAUCH KD20.2AT/K	HOSE KD20.2AT/K	TUYEAU KD20.2AT/K
* 8303966	SCHLAUCH KD40.2	HOSE KD40.2	TUYEAU KD40.2
9513208	DOPPELNIPPEL 1/2" X 3/4"	DOUBLE NIPPLE 1/2" X 3/4"	NIPPLE DOUBLE 1/2" X 3/4"

ELEKTROTEILE

ELECTRICAL PARTS

PIECES ELECTRIQUES



ET1-2.doc / 12/11/03

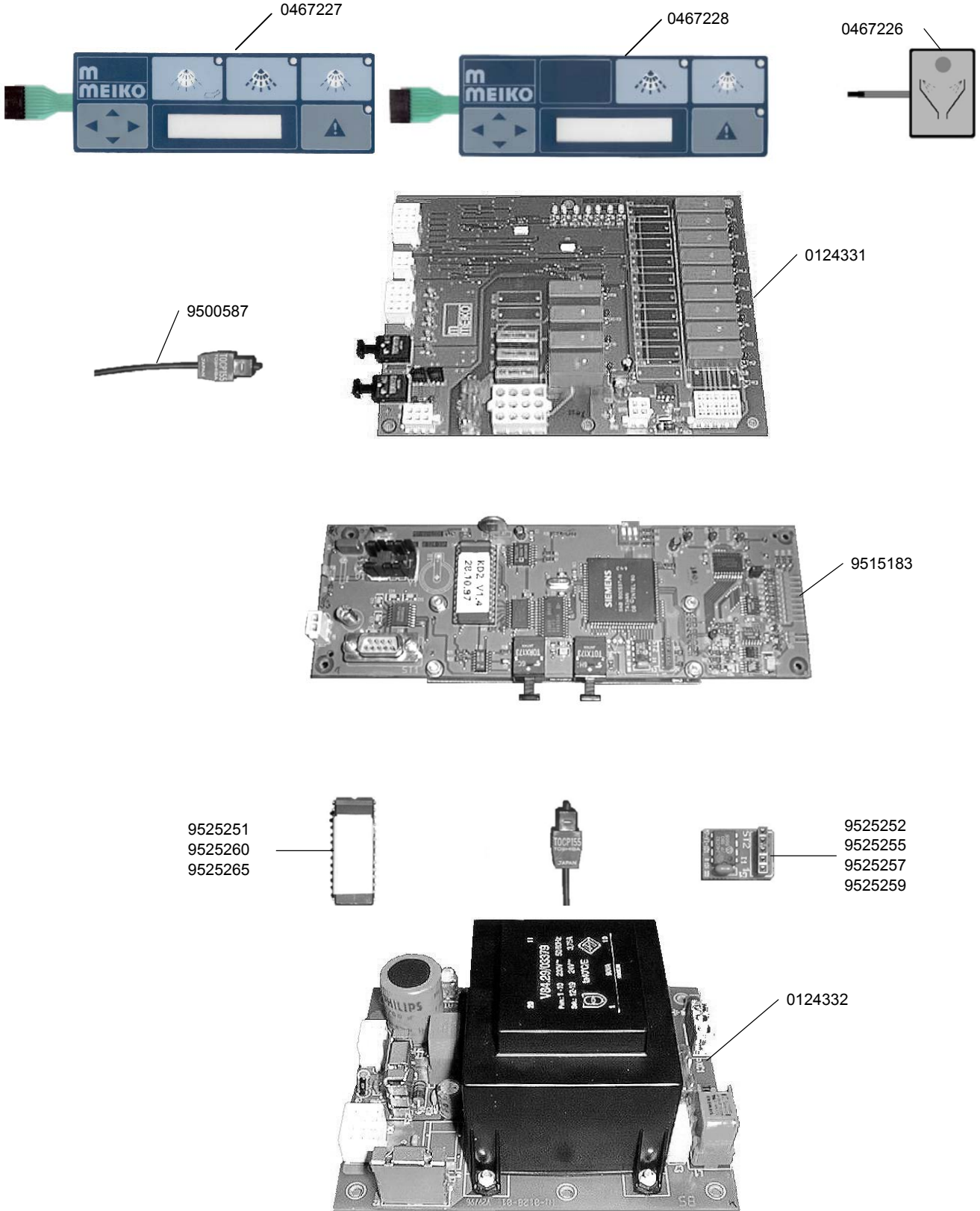

IDENT.-NR. IDENT.-NO.	BEZEICHNUNG	DESIGNATION	DESIGNATION
* 0124331	LEITERPLATTE M7-VI-E/A1	CIRCUIT BOARD M7-VI-E/A1	PLATINE A COMMANDE M7-VI-E/A1
* 9515183	LEITERPLATTE M7-VI-LCD2	CIRCUIT BOARD M7-VI-LCD2	PLATINE A COMMANDE M7-VI-LCD2
* 0124332	LEITERPLATTE M7-VI NETZ 230V/24V/12V, 50-60HZ	CIRCUIT BOARD M7-VI 230V/24V/12V,50-60 HZ	PLATINE A COMMANDE M7-VI 230V/24V/12V,50-60 HZ
* 9525251	E-PROM, NR. 1005	CHIP, NO. 1005	MICROPROCESSEUR, NO. 1005
9525260	E-PROM, NR. 4005	CHIP, NO. 4005	MICROPROCESSEUR, NO. 4005
9525265	E-PROM, NR. 7005	CHIP, NO. 7005	MICROPROCESSEUR, NO. 7005
* 9525252	M7-VI-ID1, EE-PROM, NR. 1005	M7-VI-ID1, EE-PROM, NO. 1005	M7-VI-ID1 EE-PROM, NO. 1005
* 9525255	M7-VI-ID1, EE-PROM, NR. 1105	M7-VI-ID1, EE-PROM, NO. 1105	M7-VI-ID1, EE-PROM, NO. 1105
9525257	M7-VI-ID1, EE-PROM, NR. 2005	M7-VI-ID1, EE-PROM, NO. 2005	M7-VI-ID1, EE-PROM, NO. 2005
9525259	M7-VI-ID1, EE-PROM, NR. 2105	M7-VI-ID1, EE-PROM, NO. 2105	M7-VI-ID1, EE-PROM, NO. 2105
* 0467227	FOLIENASTATUR M7-VI-FOL2	SENSOR TOUCH PANEL	TOUCHES SENSITIVES M7-VI-FOL2
* 0467228	FOLIENASTATUR M7-VI-FOL1	SENSOR TOUCH PANEL	TOUCHES SENSITIVES M7-VI-FOL1
* 0467226	FOLIENASTATUR M7-VI-FOL3	SENSOR TOUCH PANEL	TOUCHES SENSITIVES M7-VI-FOL3
* 0123216	AUSSCHALTER	CIRCUIT BREAKER	COMMUTATEUR
* 8302780	REEDKONTAKT MIT STECKER	MAGNET SWITCH	INTERRUPTEUR MAGNETIQUE
* 0457042	TÜRVERRIEGELUNG 24V, DC	DOOR LOCKING	CERRURE PORTE
9551974	TÜRVERRIEGELUNG KD30.2	DOOR LATCH KD30.2	VERROUILLAGE DE PORTE KD30.2
* 0135224	SCHÜTZ B6-30-01, 24V, 40/60HZ	CONTACTOR B6-30-01, 40/60HZ	CONTACTEUR B6-30-01, 40/60HZ
* 8303815	TEMPERATURFÜHLER (ROT) KD10.2/KF20.2/KD30.2	TEMPERATURE PROBE (RED) KD10.2/KF20.2/KD30.2	SONDE DE TEMPERATURE (ROUGE) KD10.2/KF20.2/KD30.2
* 8303881	TEMPERATURFÜHLER KD40.2	TEMPERATURE PROBE KD40.2	SONDE DE TEMPERATURE KD40.2
* 0108070	DURCHFÜHRUNGSTÜLLE FÜR TEMPERATURFÜHLER	BUSHING FOR TEMPERATURE PROBE	PASSAGE DE CABLE POUR SONDE DE TEMPERATURE
0175006	SCHLAUCHKLEMME SNP2	HOSE CLAMP SNP2	PINCE POUR TUYEAU SNP2
9502635	KABELBAUM KD10.2/KD20.2	WIRE HARNESS KD10.2/KD20.2	ARBRE DE CABLES KD10.2/KD20.2
9502649	KABELBAUM KD30.2	WIRE HARNESS KD30.2	ARBRE DE CABLES KD30.2
9502643	KABELBAUM KD40.2	WIRE HARNESS KD40.2	ARBRE DE CABLES KD40.2
* 9500587	LICHTLEITER	OPTICAL FIBRE	FIBRE OPTIQUE
0140060	SPINDELMOTOR KD.2	HYDRAULIC CYLINDER	VERIN HYDRAULIQUE
0122104	SCHALTER AT-DRÜCKER	SWITCH FOR AUTOMATIC DOOR PUSHER	INTERRUPTEUR POUR POUSSOIR AUTOMATIQUE DE PORTE
0122017	SCHALTER AT-MECHANIK	SWITCH FOR AUTOMATIC DOOR MECHANISM	INTERRUPTEUR POUR MECANISME AUTOMATIQUE DE PORTE
9500419	HAUBE FÜR STEUERUNG KD10.2/KD20.2/KD30.2	COVER FOR CIRCUIT BOARD KD10.2/KD20.2/KD30.2	COUVERTURE POUR PLATINE A COMMANDE KD10.2/KD20.2/KD30.2
9500033	HAUBE FÜR STEUERUNG KD40.2	COVER FOR CIRCUIT BOARD KD40.2	COUVERTURE POUR PLATINE A COMMANDE KD40.2
0620472	HAUBE FÜR NETZTEIL	COVER FOR POWER SUPPLY	COUVERTURE POUR ALIMENTATION ELECTRIQUE
* 9500396	FLACHBANDKABEL 2-ADRIG X160	2 WIRE RIBBON CABLE X160	CABLE A RUBAN A 2 BRINS X160
9527586	DRUCKSCHALTER	PRESS SWITCH	INTERRUPTEUR A POUSSOIR

DOSIERSYSTEM DEK UND DR

DOSING UNIT DEK, DR

SYSTEME DE DOSAGE DEK, DR

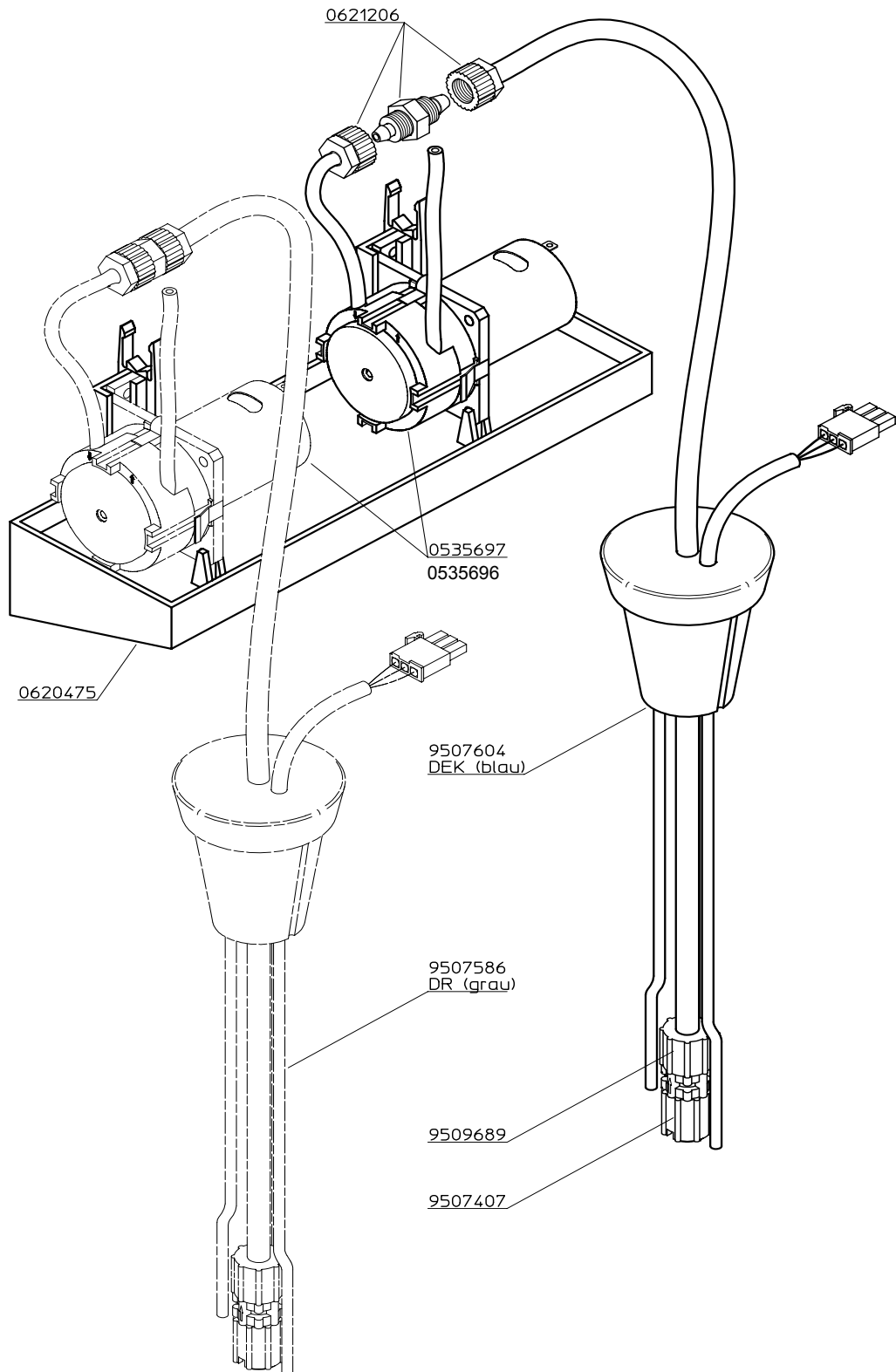

DOSIERSYSTEM DEK UND DR



DOSING UNIT DEK, DR

SYSTEM DE DOSAGE DEK, DR

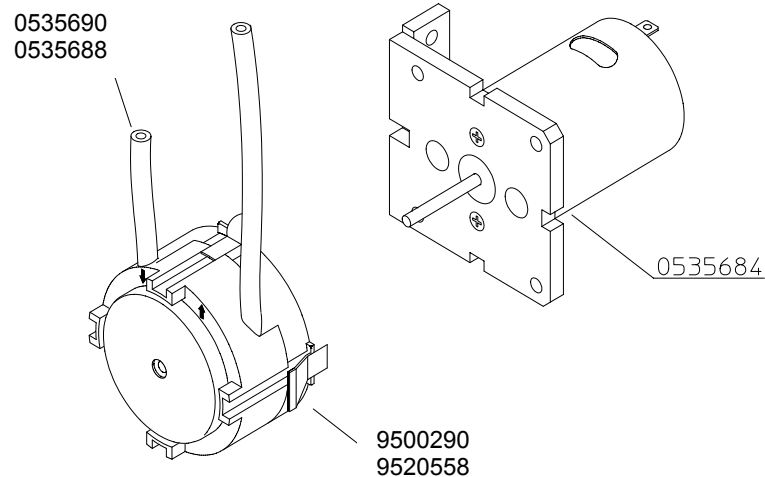

IDENT.-NR. IDENT.-NO.	BEZEICHNUNG	DESIGNATION	DESIGNATION
0620475	AUFFANGWANNE FÜR DOSIERGERÄT	DRIP PAN FOR DOSING UNIT	TOLE D'EGOUTTAGE POUR DOSEUR
* 0535696	DOSIERPUMPE SR10/50, 4LTR/H	DOSING UNIT SR10/50, 4LTR/H	DOSEUR SR10/50, 4 LTR/H
* 0535697	DOSIERGERÄT SR10/50, 6LTR/H	DOSING UNIT SR10/50, 6LTR/H	DOSEUR SR10/50, 6 LTR/H
0535684	MOTOR 12V=3000 UPM	MOTOR 12 V =3000 UPM	MOTEUR 12 V =3000 UPM
V 9520558	PUMPE F. DOSIERGERÄT, 4LTR/H	DOSING PUMP 4LTR/H	POMPE DE DOSAGE 4LTR/H
V 9500290	PUMPE F. DOSIERGERÄT, 6LTR/H	DOSING PUMP 6LTR/H	POMPE DE DOSAGE 6LTR/H
* 0535688	SCHLAUCH FÜR DOSIERGERÄT SILIKON $\varnothing 2,0 \times 1,6$	HOSE FOR DOSING UNIT SILICONE $\varnothing 2,0 \times 1,6$	TUYEAU SILICONE POUR DOSEUR $\varnothing 2,0 \times 1,6$
* 0535690	SCHLAUCH FÜR DOSIERGERÄT SILIKON $\varnothing 2,5 \times 1,6$	HOSE FOR DOSING UNIT SILICONE $\varnothing 2,5 \times 1,6$	TUYEAU SILICONE POUR DOSEUR $\varnothing 2,5 \times 1,6$
* 0621206	SCHLAUCHVERBINDUNG	HOSE CONNECTION	CONNEXION DE TUYEAU
* 9507604	SAUGLANZE BLAU DEK KOMPL.	SUCTION LANCE BLUE	LANCE D'ASPIRATION BLEU
9507586	SAUGLANZE GRAU DR KOMPL.	SUCTION LANCE GREY	LANCE D'ASPIRATION GRIS
V 9509689	FUSSVENTIL	FOOT VALVE	SOUPAPE A PIEDS
V 9507407	KAPPE FÜR FUSSVENTIL	CAP FOR FOOT VALVE	PROTECTION POUR SOUPAPE A PIEDS
* 0275106	SCHLAUCH PE WEICH $\varnothing 8 \times 6 \times 1$	FLEXIBLE HOSE $\varnothing 8 \times 6 \times 1$	TUYEAU FLEXIBLE $\varnothing 8 \times 6 \times 1$

GEFÄßEHALTER



VESSEL HOLDER

SUPPORT BOCAUX

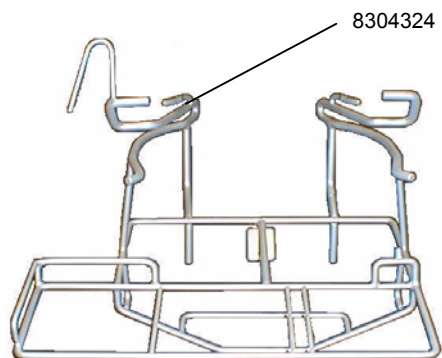
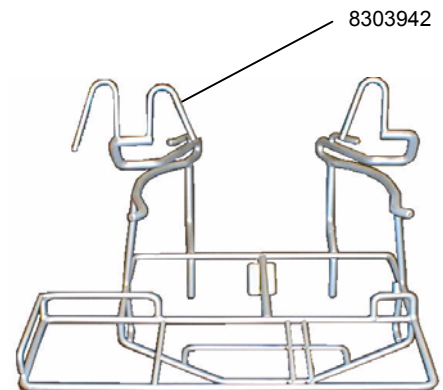
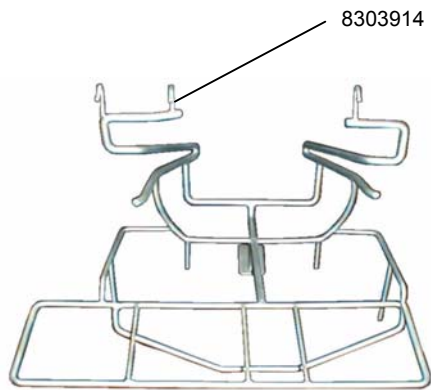

IDENT.-NR. IDENT.-NO.	BEZEICHNUNG	DESIGNATION	DESIGNATION
8303914	GEFÄSSEHALTER GUH-NR.1	VESSEL HOLDER GUH-NO.1	SUPPORT BOCAUX GUH-NO.1
8303942	GEFÄSSEHALTER GUH-NR.2	VESSEL HOLDER GUH-NO.2	SUPPORT BOCAUX GUH-NO.2
8304324	GEFÄSSEHALTER GUH-NR.3	VESSEL HOLDER GUH-NO.3	SUPPORT BOCAUX GUH-NO. 3

SONDERSPANNUNG



SPECIAL VOLTAGE

VOLTAGE SPECIALE

IDENT.-NR. IDENT.-NO.	BEZEICHNUNG	DESIGNATION	DESIGNATION
	<u>SONDERSPANNUNG 200V/50HZ</u>	<u>SPECIAL VOLTAGE 200V/50HZ</u>	<u>VOLTAGE SPECIALE 200V/50HZ</u>
9501809	PUMPE MIT MOTOR, 200V, 50HZ, 0,55KW	PUMP WITH MOTOR, 200V, 50HZ, 0,55KW	POMPE AVEC MOTEUR, 200V, 50HZ, 0,55KW
9501811	HEIZKÖRPER 3,6KW, 200V	HEATING ELEMENT 3,6KW, 200V	RESISTANCE 3,6KW, 200V
9501810	LEITERPLATTE M7-VI, 200V, 50-60HZ	CIRCUIT BOARD M7-VI, 200V, 50-60HZ	PLATINE A COMMANDE M7-VI, 200V, 50-60HZ
9504810	HEIZKÖRPER 200V (OPTION - TANKHEIZUNG)	HEATING ELEMENT 200V (OPTIONAL - TANK HEATING)	RESISTANCE 200V (OPTIONEL - CHAUFFAGE DE BAC)
	<u>SONDERSPANNUNG 200V/60HZ</u>	<u>SPECIAL VOLTAGE 200V/60HZ</u>	<u>VOLTAGE SPECIALE 200V/60HZ</u>
9504809	PUMPE MIT MOTOR, 200V, 60HZ, 0,55KW	PUMP WITH MOTOR, 200V, 60HZ, 0,55KW	POMPE AVEC MOTEUR, 200V, 60HZ, 0,55KW
9501811	HEIZKÖRPER 3,6KW, 200V	HEATING ELEMENT 3,6KW, 200V	RESISTANCE 3,6KW, 200V
9501810	LEITERPLATTE M7-VI, 200V, 50-60HZ	CIRCUIT BOARD M7-VI, 200V, 50-60HZ	PLATINE A COMMANDE M7-VI, 200V, 50-60HZ
9504810	HEIZKÖRPER 200V (OPTION - TANKHEIZUNG)	HEATING ELEMENT 200V (OPTIONAL - TANK HEATING)	RESISTANCE 200V (OPTIONEL - CHAUFFAGE DE BAC)
	<u>SONDERSPANNUNG 220V/60HZ</u>	<u>SPECIAL VOLTAGE 220V/60HZ</u>	<u>VOLTAGE SPECIALE 220V/60HZ</u>
9501839	PUMPE MIT MOTOR, 220V, 60HZ, 0,55KW	PUMP WITH MOTOR, 220V, 60HZ, 0,55KW	POMPE AVEC MOTEUR, 220V, 60HZ, 0,55KW
	<u>SONDERSPANNUNG 230V/60HZ</u>	<u>SPECIAL VOLTAGE 230V/60HZ</u>	<u>VOLTAGE SPECIALE 230V/60HZ</u>
9521349	PUMPE MIT MOTOR, 230V, 60HZ, 0,55KW	PUMP WITH MOTOR, 230V, 60HZ, 0,55KW	POMPE AVEC MOTEUR, 230V, 60HZ, 0,55KW
	<u>SONDERSPANNUNG 240V/50HZ</u>	<u>SPECIAL VOLTAGE 240V/50HZ</u>	<u>VOLTAGE SPECIALE 240V/50HZ</u>
9536679	HEIZKÖRPER 3,6KW, 240V	HEATING ELEMENT 3,6KW, 220V	RESISTANCE 3,6KW, 220V
	<u>SONDERSPANNUNG 220V/50HZ</u>	<u>SPECIAL VOLTAGE 220V/50HZ</u>	<u>VOLTAGE SPECIALE 220V/50HZ</u>
9544612	PUMPE MIT MOTOR, 220V, 50HZ, 0,55KW	PUMP WITH MOTOR, 220V, 50HZ, 0,55KW	POMPE AVEC MOTEUR, 220V, 50HZ, 0,55KW
9539846	HEIZKÖRPER 3,6KW, 220V	HEATING ELEMENT 3,6KW, 220V	RESISTANCE 3,6KW, 220V

SPÜLKASTEN FÜR AK-RANDSPÜLUNG/WC-SPÜLUNG

FLUSHING BOX FOR RIM RINSING AK/WC

RESERVOIR D'EAU POUR RINCAGE DE BORD AK/WC

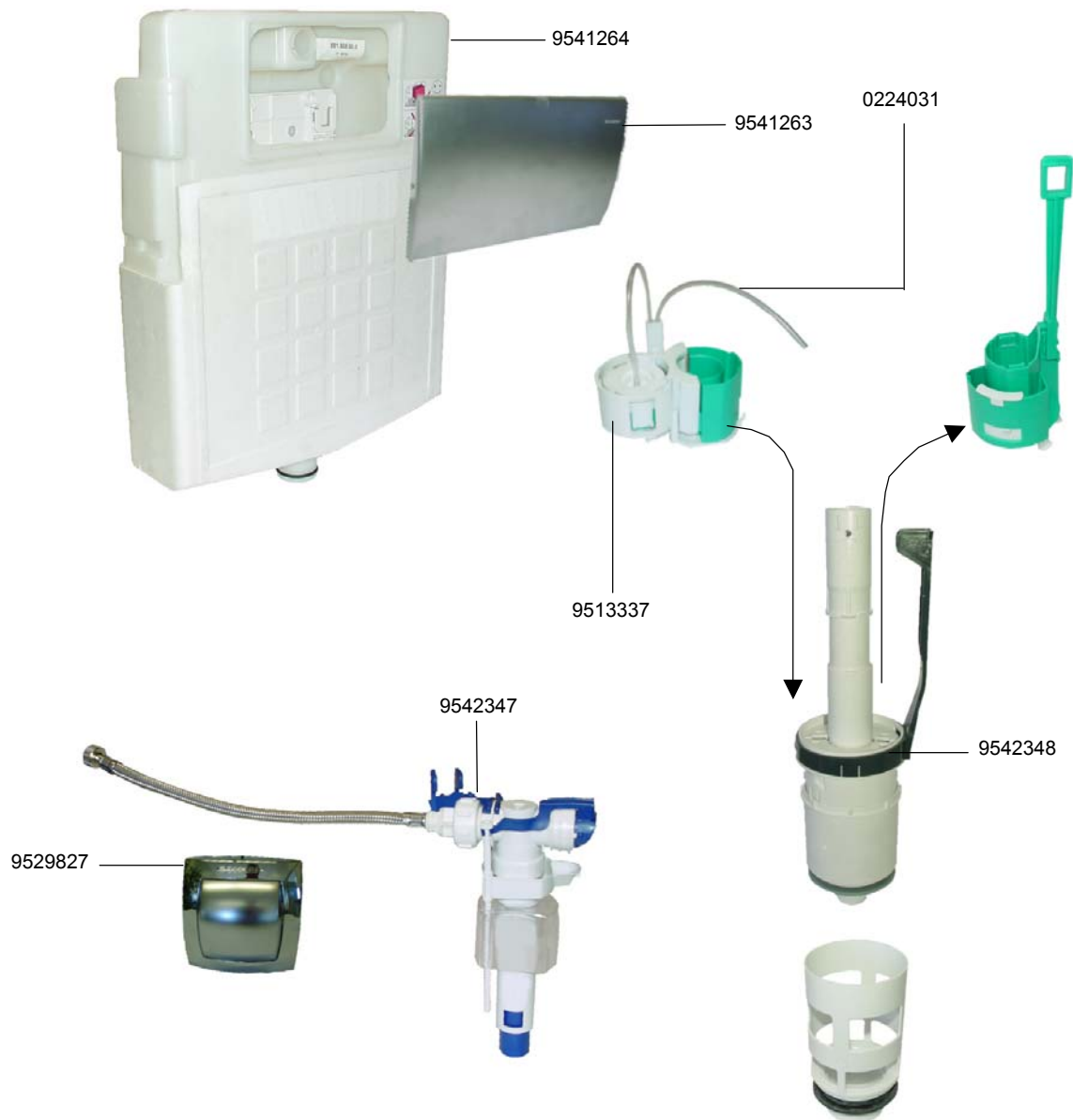

IDENT.-NR. IDENT.-NO.	BEZEICHNUNG	DESIGNATION	DESIGNATION
9541264	SPÜLKASTEN KOMPL. GEBERIT	FLUSHING BOX COMPL. GEBERIT	RESERVOIR D'EAU COMPL. GEBERIT
9541263	ABDECKPLATTE BEI AK	COVER PLATE TO AK	PLAQUE DE RECOUVREMENT
0224031	LUFTSCHLAUCH	AUR TUBE	TUYAU D'AIR
* 9513337	PNEUMATIK- HEBER	FILLING ARM	BRAS-CONTROLE DE REMPLISSAGE
9542348	SPÜLGARNITUR (UMRÜSTEN)	FILLING CONTROL (TO MODIFY)	CLOCHE-CONTROLE DE REMPLISSAGE
9542347	FÜLLVENTIL	FILLING VALVE	VANNE DE REMPLISSAGE
* 9529827	UP-DRÜCKER	UP-PUSHER	UP-POUSOIR

MECHANISCHE TÜRÖFFNUNG KD.2 MT



MECHANICAL DOOR OPENING KD.2 MT

OUVERTURE MECANIQUE DES PORTES KD.2 MT

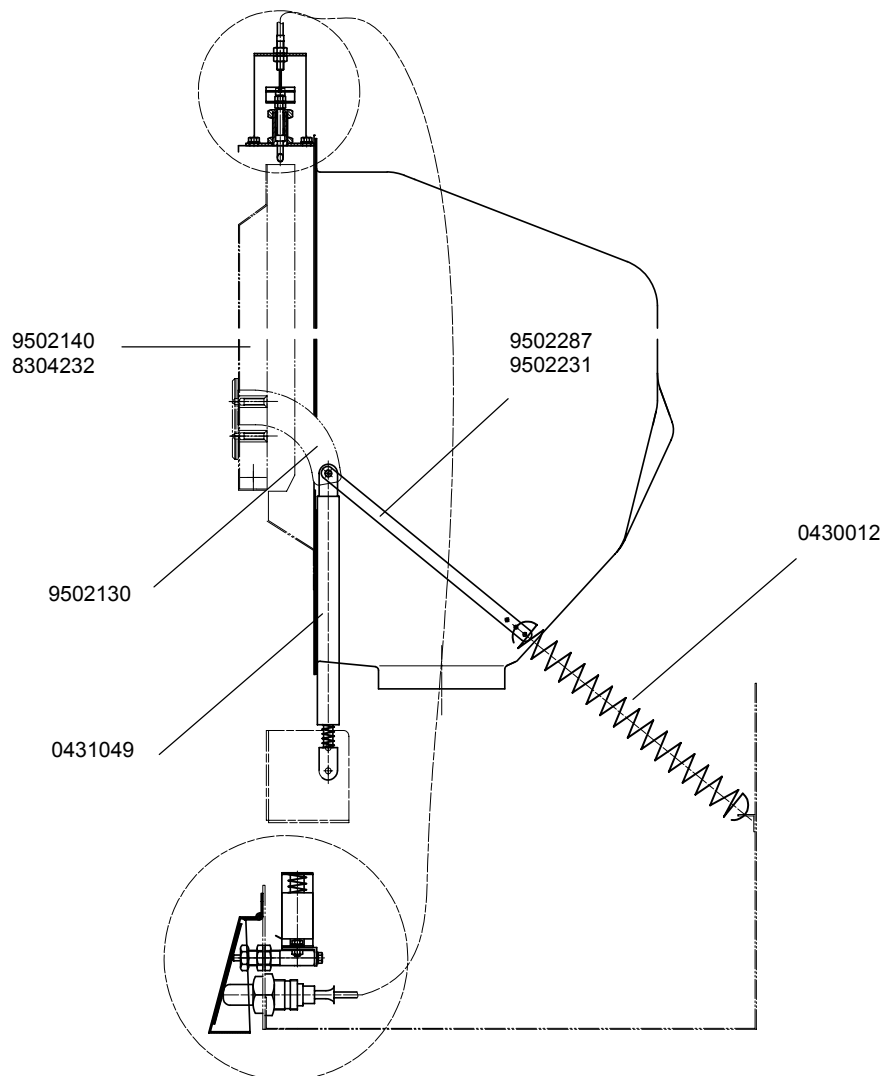

IDENT.-NR. IDENT.-NO.	BEZEICHNUNG	DESIGNATION	DESIGNATION
9502140	TÜR FÜR KAMMER MIT UMLENKHEBEL KPL.	DOOR FOR CHAMBER WITH REVERSING LEVER CPL.	PORTE DE SAS AVEC LEVIER DE RENVOI CPL.
8304232	TÜR FÜR KAMMER OHNE UMLENKHEBEL	DOOR FOR CHAMBER WITHOUT REVERSING LEVER	PORTE DE SAS SANS LEVIER DE RENVOI
9502130	UMLENKHEBEL	BEARING ANGLE KPL	ANGLE DE SUPPORT COMPLET
* 0431049	GASDRUCKFEDER	GAS PRESSURE SPRING	RESSORT DE PRESSION DE GAZ
0430012	ZUGFEDER BLAU	EXTENSION SPRING	RESSORT DE TRACTION BLEU
9502287	HEBEL, KD 20.2	LEVER, KD 20.2	LEVIER, KD 20.2
9502231	HEBEL, KD 40.2	LEVER, KD 40.2	LEVIER, KD 40.2
9534007	BLENDE SEITLICH, KD 20.2	LATERAL SHEET, KD 20.2	TOLE LATERALE, KD 20.2
8304455	BLENDE, KD 40.2	SHEET, KD 40.2	TOLE, KD 40.2

MECHANISCHE TÜRÖFFNUNG KD.2 MT, VERRIEGELUNG



MECHANICAL DOOR OPENING KD.2 MT, LOCK

OUVERTURE MECANIQUE DES PORTES KD.2 MT, VERROUILLAGE

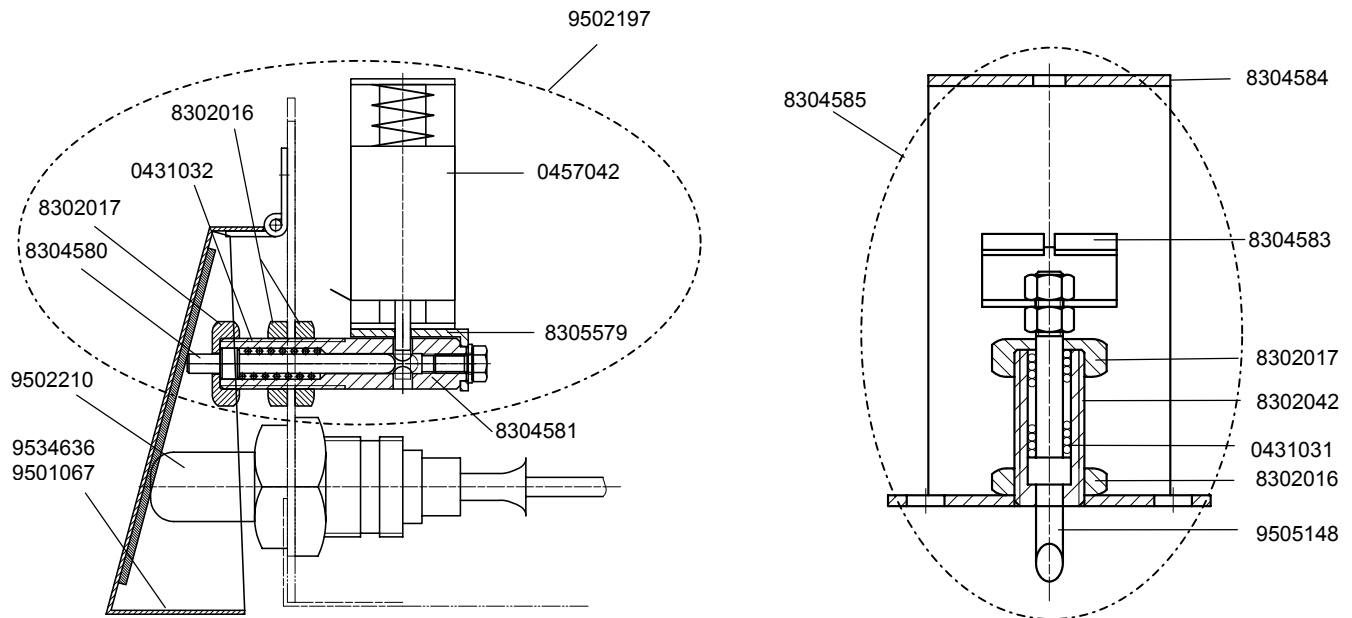

IDENT.-NR. IDENT.-NO.	BEZEICHNUNG	DESIGNATION	DESIGNATION
* 9502197	PEDAL-VERRIEGELUNG KPL.	PEDAL-LOCK COMPLETE	VERROUILLAGE PEDALE COMPLET
0457042	TÜRVERRIEGELUNGSMAGNET	DOOR LATCH MAGNET	AIMANT DE VERROUILLAGE DE PORTE
8305579	BEFESTIGUNGSWINKEL	ANGLE BRACKET	CORNIERE DE FIXATION
8304581	VERRIEGELUNGSZYLINDER	LOCKING CYLINDER	CYLINDRE DE VERROUILLAGE
8302016	MUTTER 1/4"	NUT 1/4"	ECROU 1/4"
0431032	FEDER	SPRING	RESSORT
8302017	ÜBERWURFMUTTER	UNION NUT	ECROU D'ACCOUPEMENT
8304580	VERRIEGELUNGSSTIFT	INTERLOCKING PIN	BROCHE DE VERROUILLAGE
V 9502210	BOWDENZUG	BOWDEN CABLE	CABLE BOWDEN
9534636	FUSSPEDAL, KD 20.2	PEDAL, KD 20.2	PEDALE, KD 20.2
9501067	FUSSPEDAL, KD 40.2	PEDAL, KD 40.2	PEDALE, KD 40.2
8304585	KAMMERTÜR VER-/ ENTRIEGELUNG KPL.	CHAMBER DOOR LOCKING AND DISLOCKING CPL.	PORTE DE CHAMBRE VERROUILLAGE DEVERROUILLAGE CPL.
8304584	HALTERUNG FÜR TÜRVERRIEGELUNG	HOLDING DEVICE FOR DOOR LOCK	FIXATION POUR VERROUILLAGE DE PORTE
8304583	ZUGBLECH	TIE SHEET	PLAQUE DE TRACTION
8302017	ÜBERWURFMUTTER	UNION NUT	ECROU D'ACCOUPEMENT
* 8302042	VERRIEGELUNGSZYLINDER	LOCKING CYLINDER	CYLINDRE DE VERROUILLAGE
* 0431031	FEDER	SPRING	RESSORT
8302016	MUTTER 1/4"	NUT 1/4"	ECROU 1/4"
* 9505148	VERRIEGELUNGSSTIFT	INTERLOCKING PIN	BROCHE DE VERROUILLAGE

AUTOMATISCHE TÜRÖFFNUNG KD.2 AT



AUTOMATIC DOOR OPENING KD.2 AT

OUVERTURE AUTOMATIQUE DES PORTES KD.2 AT

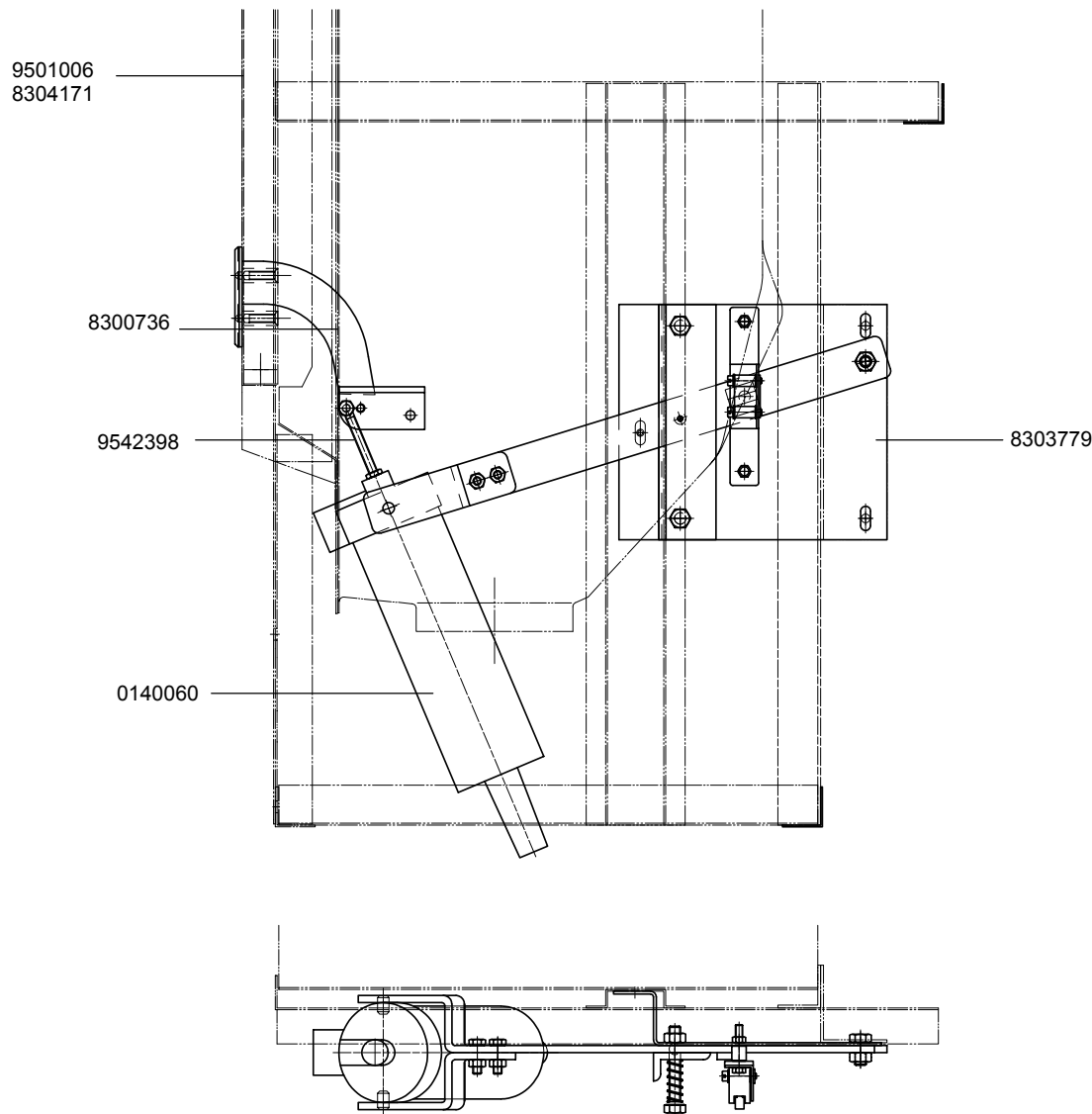

IDENT.-NR. IDENT.-NO.	BEZEICHNUNG	DESIGNATION	DESIGNATION
9501006	TÜR FÜR KAMMER MIT UMLENKHEBEL KPL.	DOOR FOR CHAMBER WITH REVERSING LEVER CPL.	PORTE DE SAS AVEC LEVIER DE RENVOI CPL.
8304171	TÜR FÜR KAMMER OHNE UMLENKHEBEL	DOOR FOR CHAMBER WITHOUT REVERSING LEVER	PORTE DE SAS SANS LEVIER DE RENVOI
8300736	UMLENKHEBEL	REVERSING LEVER	LEVIER DE RENVOI
9542398	AUGENSCHRAUBE	EYE BOLT	BOULON A OILLET
* 0140060	HUBZYLINDER	LIFTING CYLINDER	CYLINDRE DE LEVAGE
8303779	LAGERWINKEL KPL. VORMONTIERT	BEARING ANGLE CPL. PREMOUNTED	ANGLE DE SUPPORT COMPLET PREMONTÉE
9534007	BLENDE SEITLICH, KD 20.2	LATERAL SHEET, KD 20.2	TOLE LATÉRALE, KD 20.2
8304455	BLENDE, KD 40.2	SHEET, KD 40.2	TOLE, KD 40.2

AUTOMATISCHE TÜRÖFFNUNG KD.2 AT, LAGERWINKEL



AUTOMATIC DOOR OPENING KD.2 AT, BEARING ANGLE

OUVERTURE AUTOMATIQUE DES PORTES KD.2 AT, ANGLE DE SUPPORT

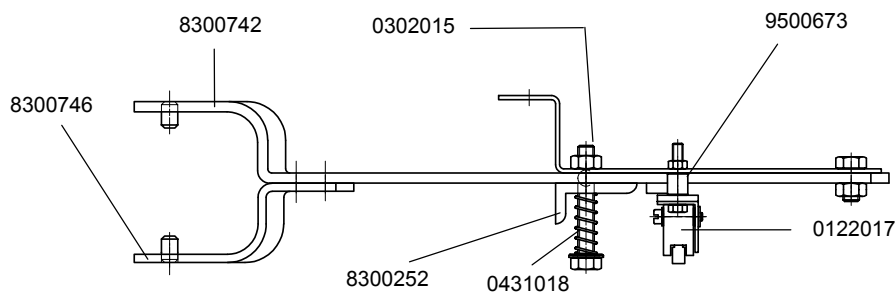
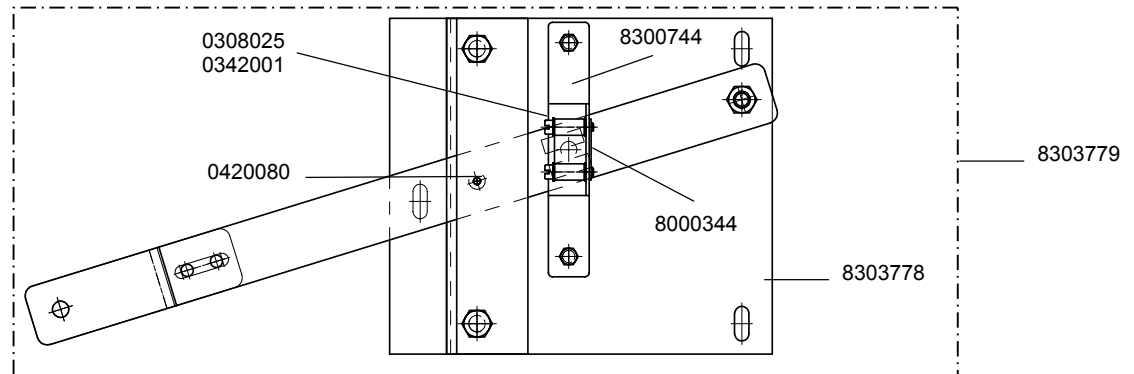

IDENT.-NR. IDENT.-NO.	BEZEICHNUNG	DESIGNATION	DESIGNATION
8303779	LAGERWINKEL KPL. VORMONTIERT	BEARING ANGLE CPL. PREMOUNTED	ANGLE DE SUPPORT COMPLET PREMONTÉE
8300744	HALTERUNG MIT SCHIENE	HOLDING DEVICE WITH RAIL	FIXATION AVEC RAIL
8000344	HALTEPLATTE	SUPPORT PLATE	PLAQUE DE SUPPORT
8303778	LAGERWINKEL FÜR SPINDELMOTOR	BEARING ANGLE FOR SPIRAL DRIVE MOTOR	ANGLE DE SUPPORT POUR MOTEUR D'ENTRAÎNEMENT HELICOÏDAL
* 0122017	GRENZTASTER	LIMIT SWITCH	INTERRUPTEUR-LIMITEUR
0431018	DRUCKFEDER 15X65X2	PRESSURE SPRING 15X65X2	RESSORT DE PRESSION 15X65X2
8300252	DRUCKPLATTE	PRESSURE PLATE	PLAQUE DE PRESSION
8300746	HALTER KURZ KPL.	HOLDING DEVICE SHORT	SUPPORT COURT CPL.
8300742	HALTER LANG KPL.	HOLDING DEVICE LONG CPL.	SUPPORT LONG CPL.
0302015	SKT.-SCHRAUBE M 8X55	HEXAGON SCREW M 8X55	VIS HEXAGONALE M 8X55
9500673	DISTANZBUCHSE	DISTANCE BUSH	DOUILLE D'ECARTEMENT
0420080	KUGEL Ø8MM	BALL Ø 8MM	BILLE Ø 8MM
0308025	ZYLINDERKOPFSCHRAUBE	SCREW	VIS
0342001	ZAHNSCHEIBE D4	TOOTH LOCK WASHER	RONDELLE A FENTE

AUTOMATISCHE TÜRÖFFNUNG KD.2 AT, FUSSPEDAL



AUTOMATIC DOOR OPENING KD.2 AT, PEDAL

OUVERTURE AUTOMATIQUE DES PORTES KD.2 AT, PEDALE

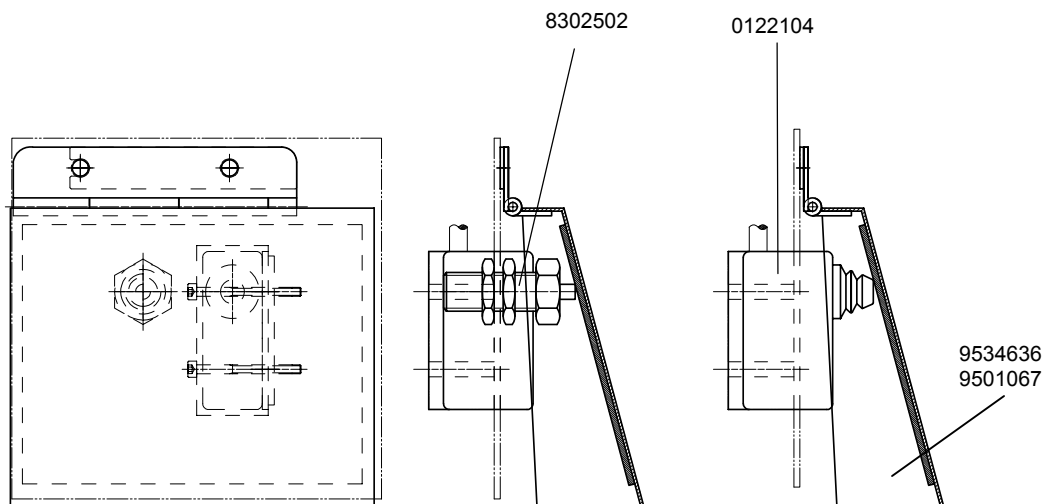

IDENT.-NR. IDENT.-NO.	BEZEICHNUNG	DESIGNATION	DESIGNATION
83032502	DRÜCKERGARNITUR	SWITCH SET	ENSEMBLE DE COMMUTATEURS
* 0122104	MIKROSCHALTER	MICRO SWITCH	MICROCOMMUTEUR
9534636	FUSSPEDAL, KD 20.2	PEDAL, KD 20.2	PEDALE, KD 20.2
9501067	FUSSPEDAL, KD 40.2	PEDAL, KD 40.2	PEDALE, KD 40.2