

# POS. 1.0 WASCHPUMPE 2 KW



# POS. 1.0 WASH PUMP 2 KW

# POS. 1.0 POMPE DE LAVAGE 2 KW

POS.	IDENT.-NR. IDENT.-NO.	BEZEICHNUNG	DESIGNATION	DESIGNATION
1	0501086	PUMPE 2 KW (1205) KPL.	PUMP 2 KW (1205) CPL.	POMPE 2 KW (1205) CPL.
2	0501122	LUEFTERFLUEGEL	FAN BLADE	AILE DE VENTILATION
3	0501102	KLEMMKASTENDECKEL 0,9/2KW 1483090/088 M.SCHR.U.DICH	TERMINAL BOX LID WITH SCREWS AND PACKING	COUVERCLE DE BOITE A BORNE AVEC VIS ET JOINT
4	0501109	PUMPENDECKEL OHNE LAGER- SCHILD FUER PUMPE 2KW	PUMP LID FOR PUMP 2 KW	COUVERCLE DE POMPE POUR POMPE 2 KW
5	0501101	PUMPENGEHÄUSEDICHTUNG	PACKING FOR PUMP HOUSING	JOINT POUR CORPS DE POMPE
6	0501161	GLEITRINGDICHTUNG KPL.	SLIDING SEAL CPL.	JOINT AXIAL CPL.
7	0501110	PUMPENLAUFRAD KST	PUMP IMPELLER 2 KW KST	ROUE DE POMPE 2 KW KST
8	0336005	HUTMUTTERN M 8	CAP NUT M 8 DIN	ECROU CHAPEAU M 8
9	0501097	PUMPENGEHAEUSE	PUMP HOUSING	CORPS DE POMPE
10	0303015	SKT.-SCHRAUBE M 4X25	HEXAGON SCREW M 4X25	VIS A SIX PANS M 4X25
11	0335005	SKT.-MUTTER M 4	HEXAGON NUT M 4	ECROU A SIX PANS M 4
12	0233047	SCHLAUCHKLEMME 50-70	HOSE CLAMP 50-70	COLLIER DE TUYAU 50-70
13	8002871	SCHLAUCH 50X8X85	HOSE GREEN 50X8X85	TUYAU FLEXIBLE VERT 50X8X85
14	0296002	VERBINDER CV 50 MM	CV-BONDER; 50 MM	RACCORD CV 50 MM

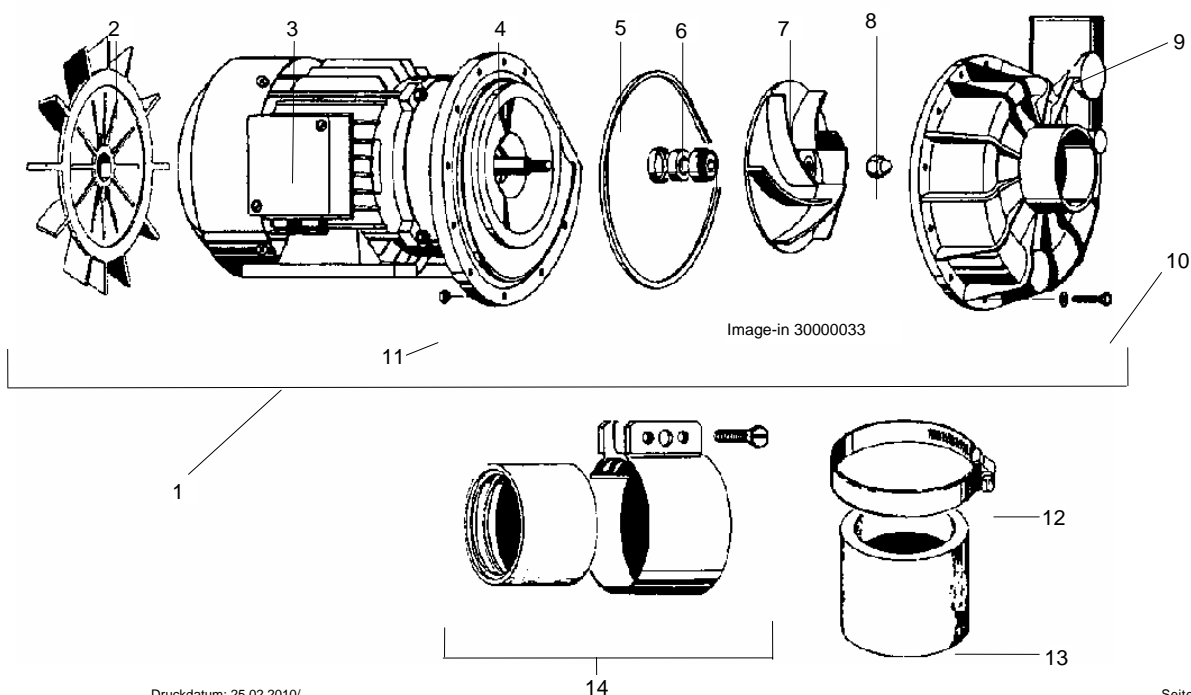

## POS. 2.0 WASCHSYSTEME



## POS. 2.0 WASH SYSTEMS

## POS. 2.0 SYSTEME DE LAVAGE

POS.	IDENT.-NR. IDENT.-NO.	BEZEICHNUNG	DESIGNATION	DESIGNATION
1	0620207	SCHLITZDUESE K106/7	LENS SLIT NOZZLE K106/7, 4,7MM,GREY,MAIN WASH ZONE	GICLEUR A JET LENTI- CULAIRE K 106/7,4,7 MM
2	0620277	WINKELADAPTER K277	ADAPTER FOR NOZZLES K 277	ADAPTEUR POUR GICLEUR K 277
3	8102048	VERSCHLUßKAPPE 12/1" 4301 D=42X14	END CAP 3/4" 4301 D=42X14	CAPUCHON DE FERM. D=42X14
4	0620161	AUSGLEICHSRING K161	LEVELLING RING K 161	BAGUE COMPENSATRICE K 161
5	0321015	SCHAFTSCHRAUBE DIN 427 M6 X 15 MM W.-NR. 1.4301	SCREW M 6X15,DIN 427, 4301	VIS M 6X15,DIN 427,4301
6	8254466	WASCHARM SEITLICH 7 DÜSEN	LATERAL WASH ARM 7 NOZZLES	BRAS DE LAVAGE LATERALE 7 GICLEURS
7	8254467	WASCHARM OBEN 4 DÜSEN	UPPER WASH ARM 4 NOZZLES	BRAS DE LAVAGE SUP. 4 GICLEURS

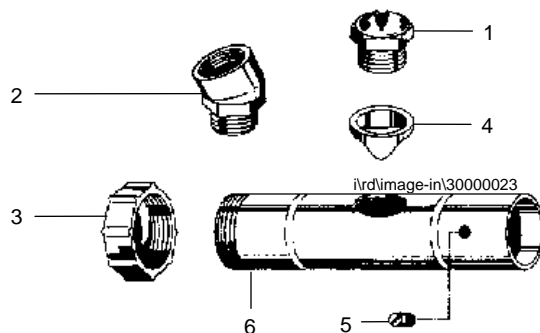

## POS. 3.0 FRISCHWASSERNACHSPÜLUNG



## POS. 3.0 FRESH WATER FINAL RINSE

## POS. 3.0 RINCAGE FINAL A L'EAU CLAIRE

POS.	IDENT.-NR. IDENT.-NO.	BEZEICHNUNG	DESIGNATION	DESIGNATION
1	0431050	SICHERUNGSRING FÜR NACHSPÜLARM	SAFETY RING FOR FINAL RINSE FIXING	BAGUE DE SECURITE POUR FIXATION DE RINCAGE FINAL
2	0401011	O-RING EPDM/EP6702-1 12 X 1,5 MM	WASHER D = 12 X 1,5	BAGUE O D=12 X 1,5
3	0321015	SCHAFTSCHRAUBE M6 X 16 MM	SCREW M 6X15,DIN 427, 4301	VIS M 6X15,DIN 427,4301
4	0472030	DÜSE 1/16" NPT-V-0,3 90 303 SS ROT	FINAL RINSE NOZZLE CRNI W. THREAD 1/16" NPT/1/MIN	GICLEUR DE RINCAGE FINAL CRNI AVEC FILET 1/16" NPT/1/MIN
5	8254476	NACHSPÜARM OBEN 5 DÜSEN	UPPER FINAL RINSE ARM 5 NOZZLES	BRAS DE LAVAGE SUP. 5 GICLEURS
	8254479	NACHSPÜLARM SEITLICH 5 DÜSEN	LATERAL FINAL RINSE ARM 5 NOZZLES	BRAS DE LAVAGE LATERALE 5 GICLEURS

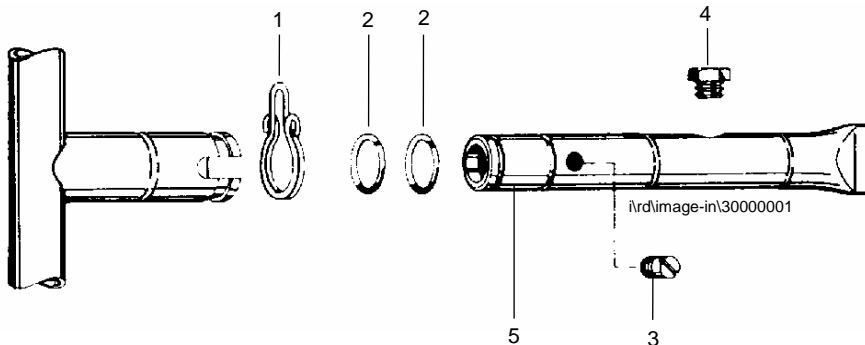

## POS. 4.0 TRANSPORTKETTE



## POS. 4.0 TRANSPORT CHAIN

## POS. 4.0 CHAINE DE TRANSPORT

POS.	IDENT.-NR. IDENT.-NO.	BEZEICHNUNG	DESIGNATION	DESIGNATION
1	8254498	TRANSPORTKETTE KPL 196 GLIEDER	TRANSPORT CHAIN CPL. 196 PARTS	GOUPILLE FENDUE DIN 94 196 MAILLONS
2	0351003	SPLINT 2 X 15 MM	SPLIT-PIN DIN 94 2 X15 MM 1.4301	GOUPILLE FENDUE DIN 94 2 X 15 MM 1.4301
3	8254496	LAUFROLLE D=15*D=6,5X15 -S-	ROLLER D=15*D=6,5X15	GALET DE CONV. 15X6,5X15
4	0340056	UNTERLEGSSCHEIBE 6,4 MM	WASHER 6,4 MM DIN 125	RONDELLE 6,4 MM, DIN 125
5	8254494	KETTENLASCHE T=25 4301 37X12X2	CHAIN PLATE T=25/37X12X2	MAILLON DE CHAINE 37X12X2
6	8254495	KETTENACHSE D=6X35 4301	CHAIN SHAFT DIA 6 X 35	BOULON DE CHAINE D=6X35

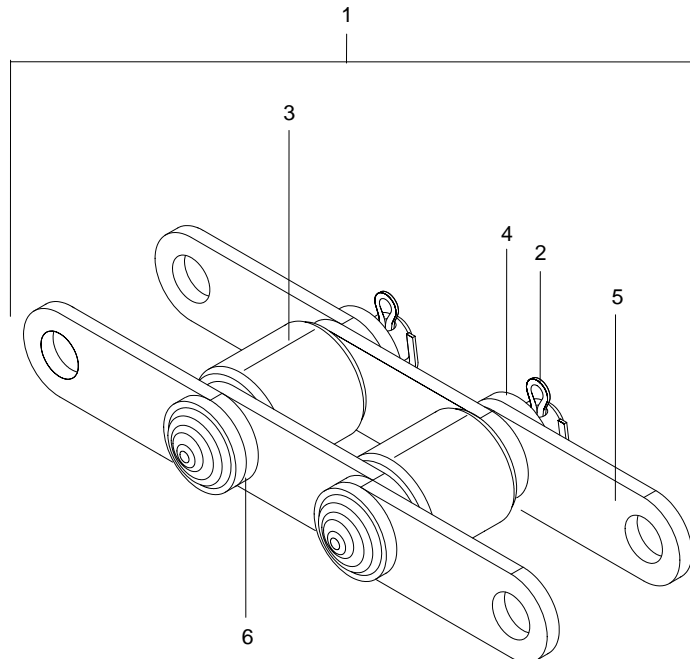

## POS. 5.0 SCHWIMMERSCHALTER, 90°



## POS. 5.0 FLOAT SWITCH, 90°

## POS. 5.0 INTERRUPTEUR FLOTTANT, 90°

POS.	IDENT.-NR. IDENT.-NO.	BEZEICHNUNG	DESIGNATION	DESIGNATION
1	8255524	DOPPELNIPPEL R=1/4" 1.4301 SCHWIMMERSCHALTER	DOUBLE NIPPLE R=1/4" 1.4301 FLOAT SWITCH	NIPPLE DOUBLE R=1/4" INTERRUPTEUR FLOTTANT
2	8250807	MUFFE R=1/4" D=17X15 1.4301	SOCKET R=1/4" D=17X15 1.4301	MANCHON R=1/4" D=17X15 1.4301
3	0343003	SICHERUNGSRING FEDERSTAHL 12 MM DIN 471	SAFETY RING SPRING STEEL 12 MM DIN 471	BAGUE DE SECURITE 12 MM DIN 471
4	0130023	SCHWIMMERSCHALTER USA F. SPUELMASCHINE	FLOATING SWITCH USA-TYPE	FLOTTEUR P. NIVEAU DE BAC TYPE USA
5	8302016	SKT-MUTTER R=1/4" SW19X5* MS	HEXAGON NUT RED BRASS R=1/4" SW19X5*	ECROU A SIX PINS R=1/4" SW19X5*
6	0340050	U-SCHEIBE 40X13X3 MM	WASHER 40X13X3 MM	RONDELLE 40X13X3 MM
7	8660312	6KT-MUTTER 1.4301 R1/4"-SW19-7	HEXAGON NUT 1.4301 R1/4"-SW19-7	ECROU A 6 PANS 1.4301 R1/4"-SW19-7

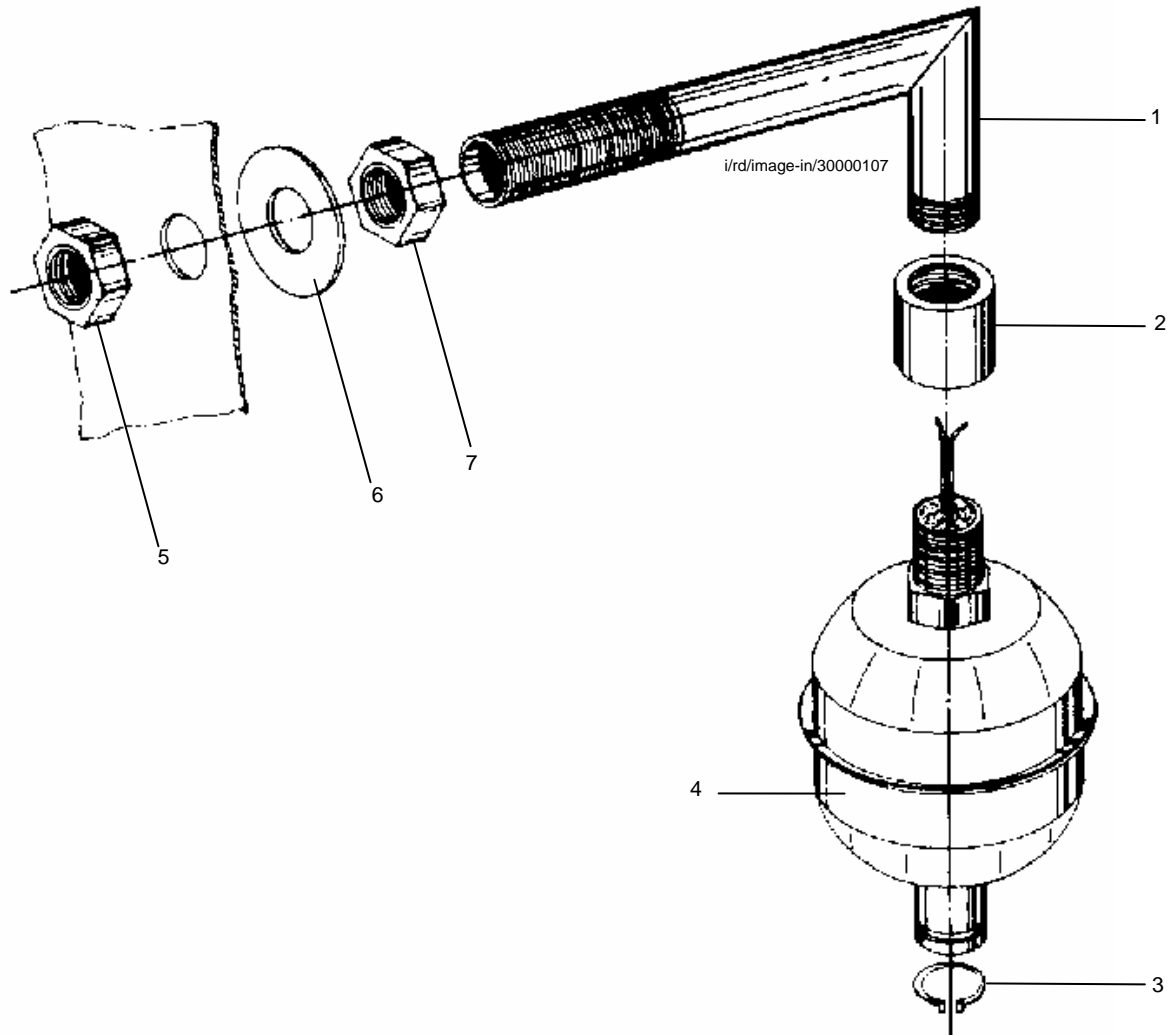

## POS. 5.1 ABLAUF



## POS. 5.1 DRAIN

## POS. 5.1 VIDANGE

POS.	IDENT.-NR. IDENT.-NO.	BEZEICHNUNG	DESIGNATION	DESIGNATION
1	0237045	KUGELHAHN 2" MS VERN. LÄNGE 111 MM	BALL VALVE 2" RED BRASS	ROBINET A BOISSEAU 2" LAITON
2	8254725	VERLÄNGERUNG-KUGELHAHN 1.4301 D20-240	EXTENSION BALL VALVE 1.4301 D20-240	PROLONGATION ROBINET A BOISSEAU 1.4301 D20-240
3	8254418	GRIFF	HANDLE	POIGNEE
4	8100374	VERRIEGELUNGSBLECH R-L	LOCK SHEET	TOLE DE VERROUILLAGE
5	8100375	DRUCKSCHEIBE D = 24 X D = 7 X2	PRESSURE DISK D = 24 X D = 7 X2	RONDELLE DE PRESSION D = 24 X D = 7 X2
6	8100377	DISTANZROHR D = 24 X 3 X 7	EXTENSION OF BALL VALVE R-L	PROLONGATION DE ROBINET A BOISSEAU D-G

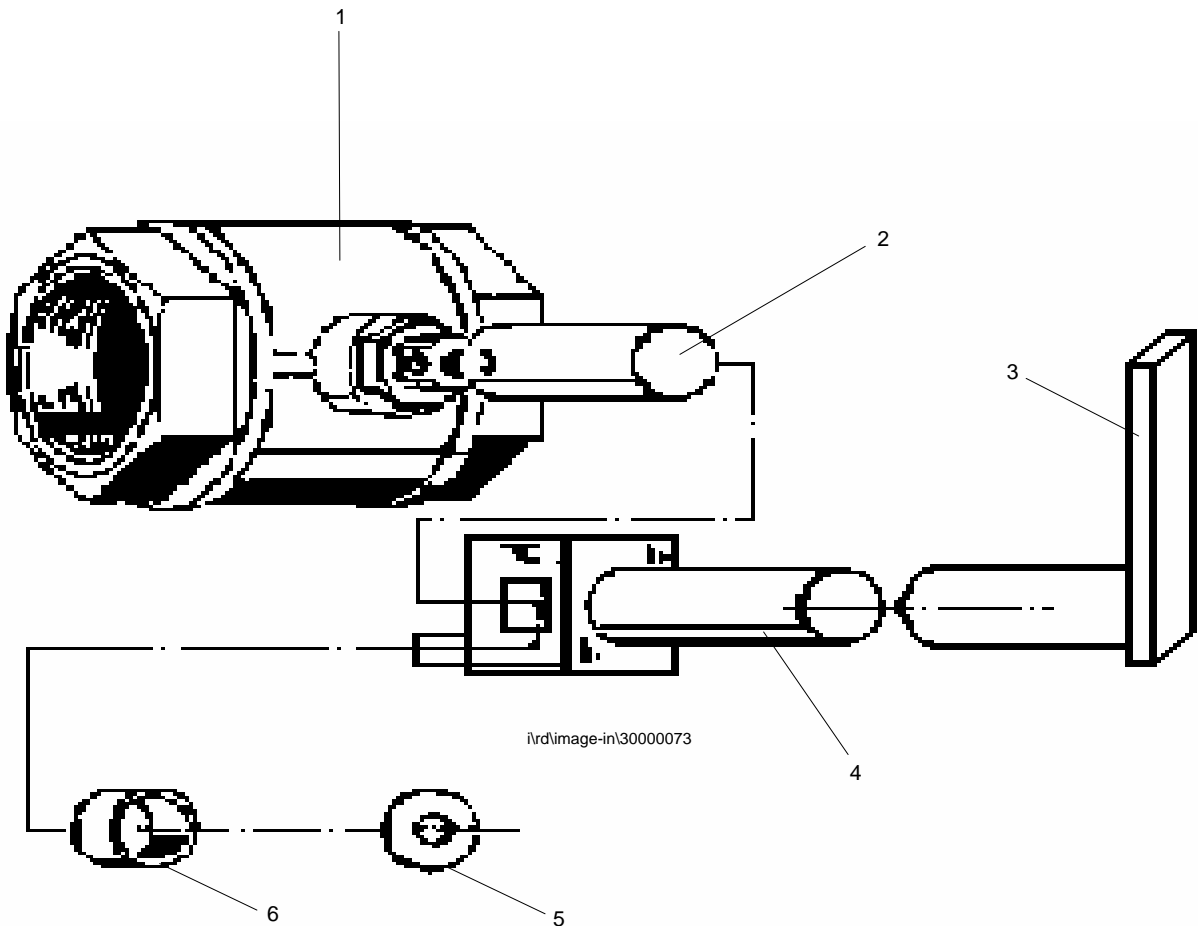

## POS.5.2 TEMPERATURREGLER



## POS. 5.2 TEMPERATURE CONTROL

## POS. 5.2 REGULATEUR DE TEMPERATURE

POS.	IDENT.-NR. IDENT.-NO.	BEZEICHNUNG	DESIGNATION	DESIGNATION
1	0108041	THERMOSTAT TYP 716 RU-1519 KAPILLARHRLAENGE 3100MM	THERMOSTAT TYP 716 RU-1519 CAPILLARY LENGTH 3100MM	THERMOSTAT TYPE 716 RU-1519 LONGUEUR DU CABLE 3100MM



i/rd/image-in/30000008

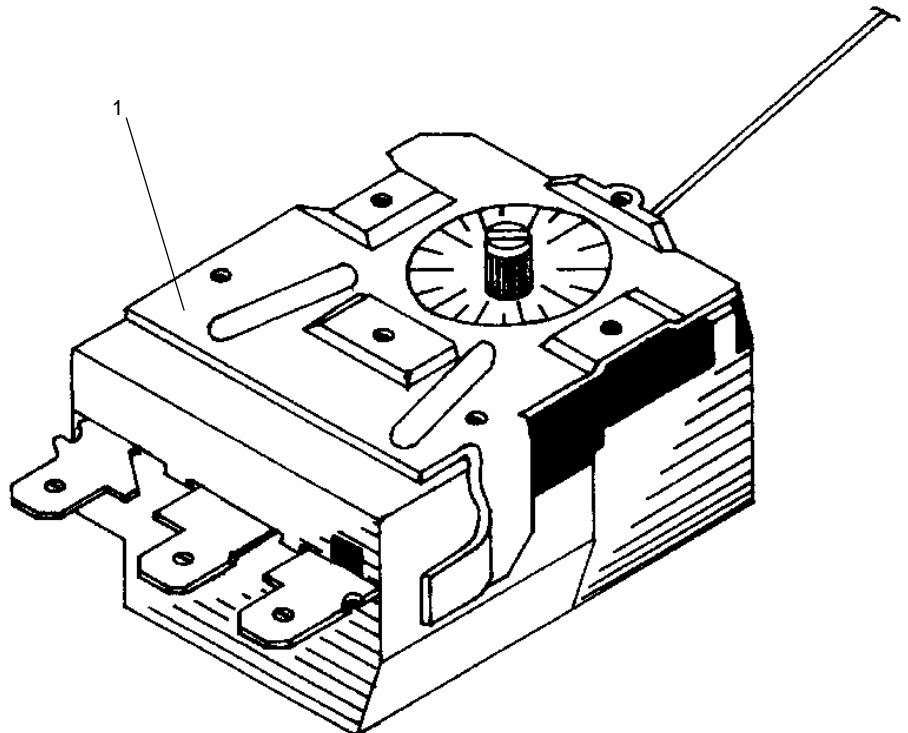

## POS. 6.1 ANTRIEBSSTATION, 50 HZ

## POS. 6.1 DRIVE STATION, 50 HZ

## POS. 6.1 STATION D'ENTRAINEMENT, 50 HZ

POS.	IDENT.-NR. IDENT.-NO.	BEZEICHNUNG	DESIGNATION	DESIGNATION
1	8254712	ANTRIEBSWELLE 50HZ	DRIVE SHAFT 50HZ	ARBRE D'ENTRAINEMENT 50HZ
2	8254706	KETTENRAD MIT NUT T 25 Z 8 D20 PPH RD 15	CHAIN WHEEL WITH NUT T 25 Z 8 D20 PPH RD 15	ROUE DE CHAINE AVEC RAINURE T 25 Z 8 D20 PPH RD 15
3	0450001	RUTSCHNABE GR. 1 10011 O.BUND D=20 MM	SAFETY CLUTCH COMPL.SIZE1 TYPE 100.11 ROBA,D=20 MM	COUPL.DE FRICTION COMPL. TAIL.1,ALESAGE D=20 MM
4	0435046	KETTENRADSCHIEBE 1/2" Z24 Ø44 STVZ	SPROCKET DISK 1/2" Z24 Ø44 STVZ	RONDELLE P. ROUE CHAINE 1/2" Z24 Ø44 STVZ
5	0343048	SICHERUNGSRING 20 MM	CIRCKLIP 20 MM	CIRCLIP 20 MM
6	8254718	U-SCHIEBE D=34/20,5X1 4301	WASHER D=34/20,5X1 4301	RONDELLE D=34/20,5X1 4301
7	8250310	BLECHFLANSCH 120X120X2 4301	SHEET FLANGE 120X120X2 4301	BRIDE EN TOLE 120X120X2 4301
8	8250215	BLECHVERSTÄRKUNG KPL. MIT SCHRAUBEN	COMPLETE REINFORCING SHEET WITH SCREWS	RENFORCEMENT CPL. EN TOLE AVEC VIS
9	8254717	LAGER KETTENRADSEITE -S- D=80X55	BEARING ON SPROCKET SIDE -S- D=80X55	PALIER DU COTE ROUE DENTEE -S- D=80X55
10	0402003	RADIALWELLENDICHTRING 20 X 30 X 7 MM	ROTARY SHAFT SEAL 20 X 30 X 7 MM	BAGUE SIMMER BA 20 X 30 X 7 MM
11	8254716	ANTRIEBSWELLE	DRIVE SHAFT	ARBRE D'ENTRAINEMENT
12	8254719	LAGER D=80X40	BEARING D=80X40	PALIER D=80X40
13	8105070	STELLRING D=45/20 1.4301 L=15 M8	FIXING RING D=45/20 1.4301 L=15 M8	BAGUE DE FIXATION D=45/20 1.4301 L=15 M8
14	8262896	KETTENRAD 1/2" MIT NUT VERZ Z=27 D=20	CHAIN WHEEL WITH NUT Z=27 D=20	ROUE DE CHAINE AVEC RAINURE Z=27 D=20

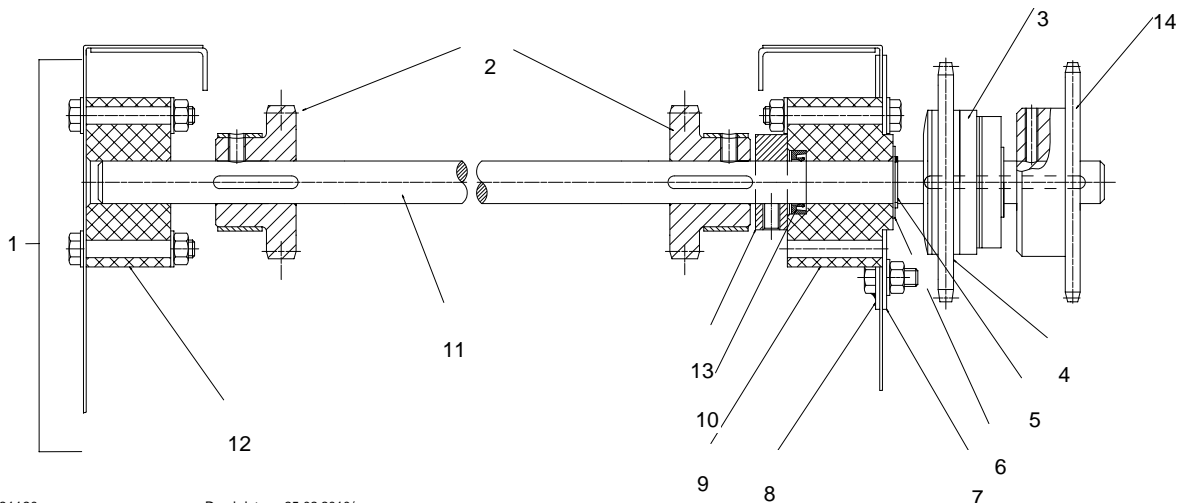



## POS. 7.0 SPANNSTATION



## POS. 7.0 REVERSE STATION

## POS. 7.0 STATION DE RETOUR

POS.	IDENT.-NR. IDENT.-NO.	BEZEICHUNG	DESIGNATION	DESIGNATION
1	8254713	SPANNWELLE KPL.	TENSION SHAFT CPL.	ARBRE DE TENSION CPL.
2	8254707	KETTENRAD-SPANNSEITE KPL T 25 Z 8 D20 PPH RD15	CHAIN WHEEL REVERSE SIDE CPL. T 25 Z 8 D20 PPH RD15	ROUE DE CHAINE CPL. T 25 Z 8 D20 PPH RD15
3	8254715	SPANNWELLE D=20X1386 4301	TENSION SHAFT D=20X1386 4301	ARBRE DE TENSION D=20X1386 4301
4	8105070	STELLRING D=45/20 1.4301 L=15 M8	FIXING RING D=45/20 1.4301 L=15 M8	BAGUE DE FIXATION D=45/20 1.4301 L=15 M8
5	8254757	UMLENKWELLENFÜHRUNG L*R 4301 L=193	REVERSE SHAFT GUIDANCE 4301 L=193 L*R	GUIDAGE D'ARBRE DE TENSION 4301 L=193 L*R

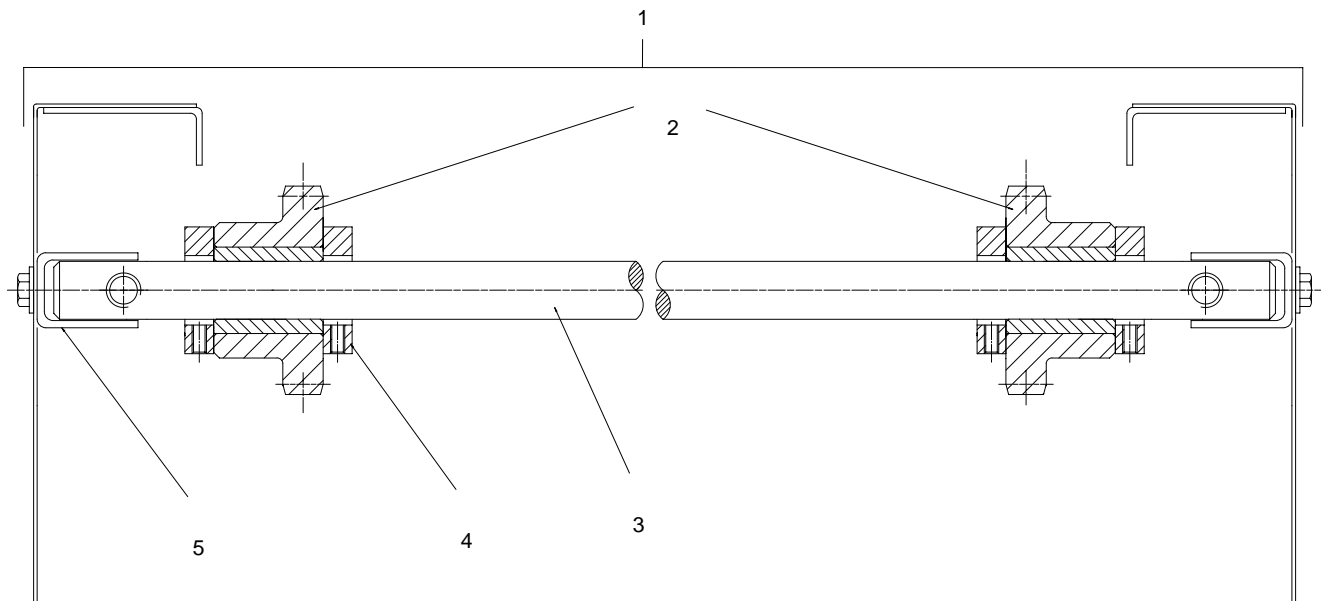

## POS. 8.0 ABSAUGGEBLÄSE Ø 400



## POS. 8.0 EXTRACTION FAN Ø 400

## POS. 8.0 VENTILATEUR D'ASPIRATION Ø 400

POS.	IDENT.-NR. IDENT.-NO.	BEZEICHNUNG	DESIGNATION	DESIGNATION
1	0550052	GEBLÄSE AXIAL FA035-VDL.2C.5	FAN AXIAL FA035-VDL.20.5	VENTILATEUR AXIAL FA035-VDL.20.5

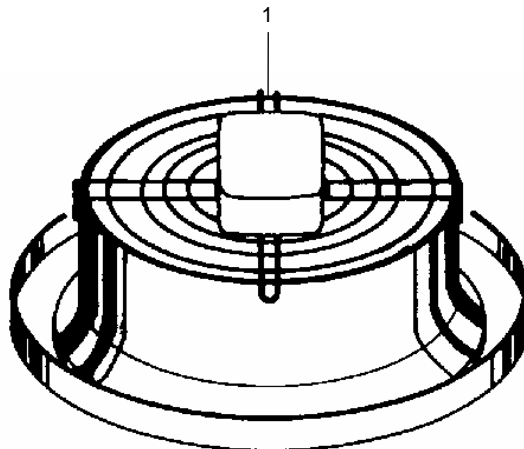

## POS. 9.0 TROCKNUNG (2,6 KW)



## POS. 9.0 DRYING

## POS. 9.0 SECHAGE

POS.	IDENT.-NR. IDENT.-NO.	BEZEICHNUNG	DESIGNATION	DESIGNATION
1	0550060	VENTILATOR NIEDERDRUCK D 08 OHNE FUSS 2,6 KW 220/380 V, 50 HZ	BLOWER; LOW PRESSURE D 08 WITHOUT BASE 2,6 KW 220/380 V, 50 HZ	VENTILATEUR; BASSE PRESS. D 08 SANS SOCLE 2,6 KW 220/380 V, 50 HZ

